

The background features a complex network of thin, light gray lines on a black field. These lines form various geometric shapes, including triangles, polygons, and curved segments. Some lines are thicker than others, creating a sense of depth and structure. In the upper left, there is a curved line with a series of small rectangular notches along its edge, resembling a gear or a decorative architectural element. The overall composition is abstract and architectural.

the collection

made design

2020-21

Our values**4**

Design	4	Acoustics	8
Recycling	6	Customisation	10

Recycling**12**

Davos	14	Berna	40	Interlaken	64	Ginebra	84
Nyon	20	Zurich	46	Baden	70	Biel	90
Lausanne	28	Basilea	52	SB_system	76	Laax	96
Vevey	34	Zell	58	Lugano	78		

Customise products in your own style**218**

Comfort**102**

Treviso	104	Bologna	134	Note-it	164	Albury	194
Bergamo	110	Padova	140	Vevey Acoustic	170	Nagoya	200
Milano	116	Torino	146	Kyoto	176	Osaka	206
Capri	122	Napoli	152	Sapporo	182	Menfis	212
Siena	128	Bamboo	158	Adelaida	188		

Designers**224**

Technical data**234**

In the beginning. That instant, that precise moment, when the pencil creates the first point, when pencil touches paper, from there it accelerates, turns, goes in a straight line, turns again, makes pirouettes, changes its meaning, a double somersault and voilà! So, our designers start to design our products with people in mind and giving them that special touch that fuses form and function.

This is what we do, design.



We generate an excessive amount of waste and one of the ways in which we can help the environment is with our recycling stations and bins to make the separation of waste easier, promote recycling and at the same time, create pieces with an authentic design, adding character and aesthetic integrated into your environment.

The planet needs help;
recycling is no longer optional.



Conversations, phone calls, environmental noise, we live surrounded by noise that prevents us from concentrating at work, in a hotel, a restaurant, etc. Paying attention to this is when we decide to create products that help reduce noise, and creating spaces that allow us to enjoy one of the most beautiful sounds in the world: silence.



We have many requests to customise our products and integrate them with your companies corporate image; either a specific colour, insertion of logo, modification of size, changes in the format to adapt to specific needs of the cleaning team, etc.

This is our way of making our products even more unique.

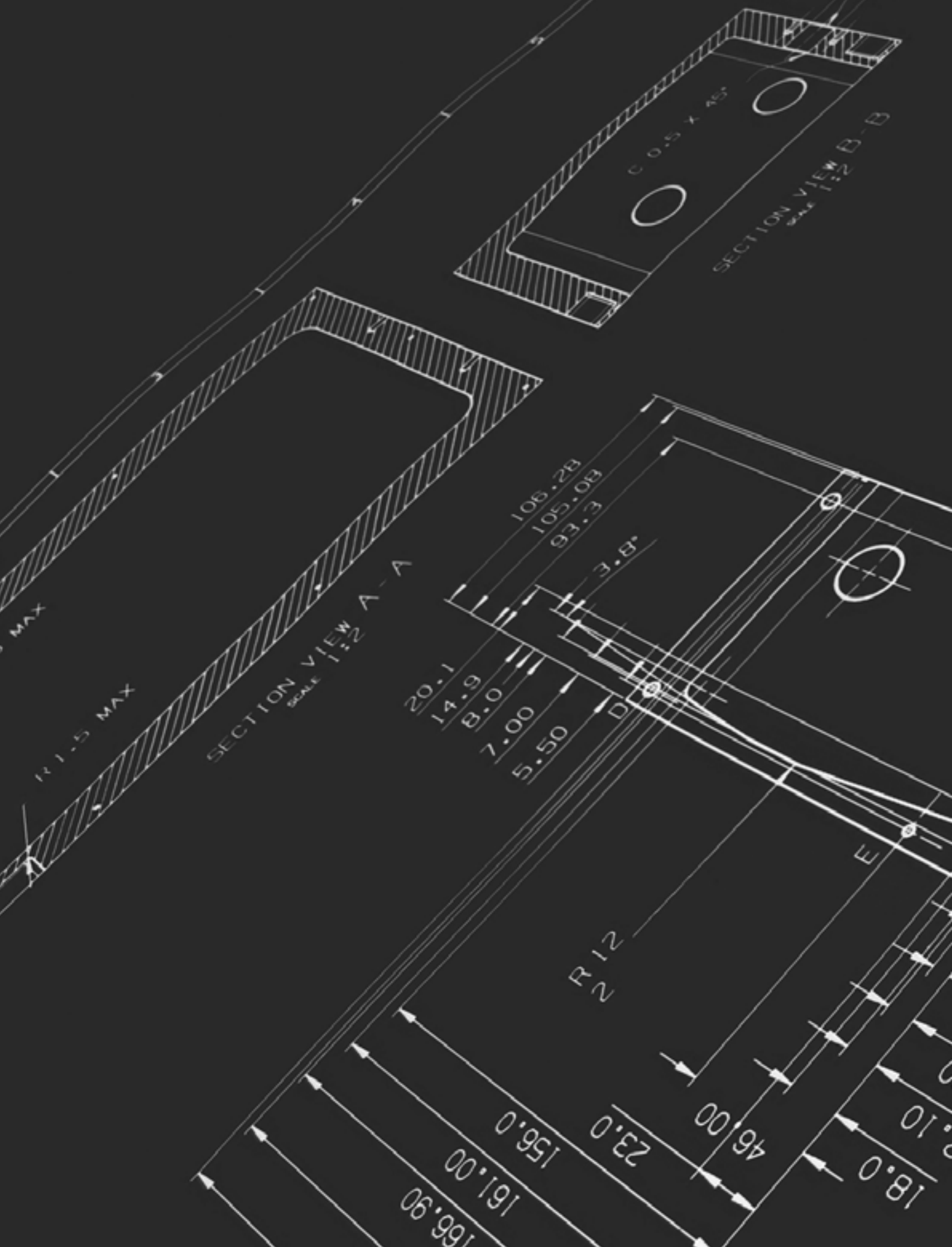

Recycling

Davos	14
Nyon	20
Lausanne	28
Vevey	34
Berna	40
Zurich	46
Basilea	52
Zell	58
Interlaken	64
Baden	70
SB_system	76
Lugano	78
Ginebra	84
Biel	90
Laax	96

Davos

RECYCLING

by Nahtrang

The ideal "point" for recycling ... place one, two, three or even four bins and your environment will be ready to recycle. Made of sheet metal with flip top lid. It is very resistant and has a bag ring for easy removal.

El "punto" de reciclaje ideal... coloca uno, dos, tres o hasta cuatro "Points" y tu espacio ya estará listo para reciclar. Fabricada en chapa metálica cilindrada y tapa abatible superior. Es muy resistente y dispone de aro porta bolsa para facilitar su uso.

Le "point" de recyclage idéal... placez un, deux, trois ou même quatre "Points" et votre espace sera prêt à recycler. Fabriquée en tôle et muni d'un couvercle rabattable. Il est très résistant et possède un anneau porte sac pour faciliter son utilisation.



**WORK
AND PLAY
HARD**





More about Davos

DESIGNER
Nahtrang

YEAR
2018

LINE SKETCH

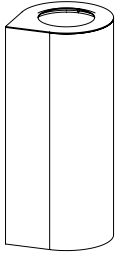

SCALE 1:20 (cm)

PRODUCT



REFERENCE
DVS 01

SIZE
30 x 30 x 73 cm – 52 L
11,8 x 11,8 x 28,7 in. – 13,7 gal.

DETAILS





COMPLETE RECYCLING POINT FOR 4 TYPES OF WASTE

RECYCLING

COLOURS

-  RAL 9003 + 3027
-  RAL 9003 + 1016
-  RAL 9003 + 6018
-  RAL 9003 + 5012

CUSTOMISE OPTIONS

-  COLOUR
-  PICTOGRAMS
-  HEIGHT & WIDTH

HUMAN PERCEPTION

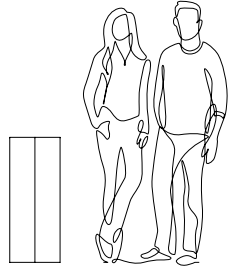

OPENING DETAIL OF LID AND RING TO HOLD WASTE BAG

Nyon

RECYCLING

by Roger Vancells

There are bins and then there's Nyon. Whose presence and character do not go unnoticed. In two sizes, with three designs and colours, and now, with a version of treated cedar wood for outdoors allowing you to integrate it perfectly into any landscape.

Hay papeleras y luego está Nyon. Su presencia y carácter la hacen no pasar inadvertida. En dos tamaños, con tres diseños y colores, y ahora, con una versión en madera de cedro tratada para exteriores, que le permite integrarse a la perfección en cualquier paisaje.

Il existe des corbeilles et puis il y a Nyon. Sa présence et son caractère ne la font pas passer inaperçue. En deux tailles, avec trois motifs et couleurs, et maintenant, avec une version en bois de cèdre traité pour l'extérieur, qui lui permet de s'intégrer parfaitement dans n'importe quel paysage.







More about Nyon

DESIGNER
Roger Vancells

YEAR
2015 / 2018

LINE SKETCH

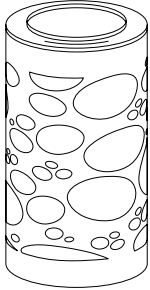

SCALE 1:20 (cm)

PRODUCT



REFERENCE

NYO 10 / 10C
NYO 12 / 12C
NYO 14 / 14C
NYO 18 / 18C

NYO 20
NYO 22
NYO 24

NYO 50
NYO 52
NYO 54

NYO 60
NYO 62
NYO 64

SIZE

Ø44 x 84 cm — 80 L
Ø17,2 x 32,8 in. — 21 gal.

C: Ashtray option

Ø23 x 44 cm — 12 L
Ø9 x 17,9 in. — 3,2 gal.

Ø23 x 44 cm
Ø9 x 17,3 in.

Ø17 x 87,8 cm
Ø6,7 x 34,6 in.

TEXTURE

 0 - ORGANIC

 2 - LINEAR

 4 - CLASSIC

 8 - WOOD

DETAILS



WOODEN NYON WASTE BIN WITH ASHTRAY — NYO 18C

RECYCLING

COLOURS

-  RAL 9003 + RAL 7016
-  RAL 7016 + RAL 7016
-  OXI + RAL 7016
-  WOOD + RAL 7016

CUSTOMISE OPTIONS

-  COLOUR
-  PATTERN
-  LOGOTYPE

HUMAN PERCEPTION

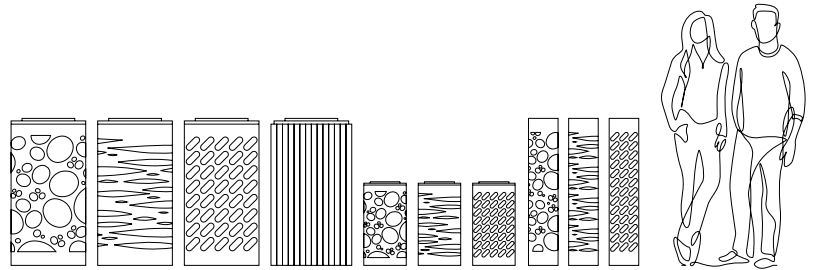

NYON CLASSIC OXI TOP OPENING WITH ASHTRAY — NYO 14C



NYON LINEAR WHITE HINGE DETAIL — NYO 12

More about Nyon

DETAILS



OPENING DETAIL NYON ORGANIC BLACK AND NYON CLASSIC WHITE – NYO 24



WHITE NYON ASHTRAY – NYO 64



NYON FAMILY

Lausanne

RECYCLING

by Toni Arola

An ideal bin for both indoor and outdoor use. Resists everything thanks to its structure made from sheet metal with its base and head in cast aluminum. In addition to the steel version, it is now in deployé, and you can choose with or without an ashtray.

Una papelera ideal tanto para interiores como para exteriores. Resiste a todo gracias a su estructura fabricada en plancha de acero y su base y cabezal en fundición de aluminio. Además de la versión acero, ahora está en deployé, y puedes elegirla con o sin cenicero.

Une poubelle idéale pour l'intérieur comme pour l'extérieur. Résiste à tout, grâce à sa structure en tôle d'acier et à sa base et sa tête en fonte d'aluminium. En plus d'une version en acier, il est maintenant disponible en métal déployé, vous pouvez la choisir avec ou sans cendrier.







More about Lausanne

DESIGNER
Toni Arola

YEAR
1990 / 2018

LINE SKETCH

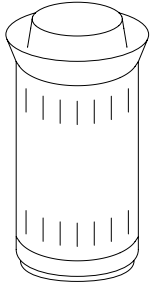

SCALE 1:20 (cm)

PRODUCT

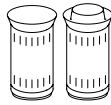

REFERENCE

LSN 01

LSN 02

LSN 01D

LSN 02D

SIZE

Ø45 x 80 cm — 120 L
Ø17,7 x 33,1 in. — 26,4 gal.

Ø45 x 80 cm — 120 L
Ø17,7 x 33,1 in. — 26,4 gal.

D: Deployé version

DETAILS



VIEW LAUSANNE DEPLOYÉ ANTHRACITE AND LAUSANNE INOX WITH ASHTRAY — LSN 01D 7016 + LSN 02 INOX

RECYCLING

COLOURS

- RAL 7016
- RAL 9006
- INOX
- D - RAL 7016
- D - RAL 9006

CUSTOMISE OPTIONS

- BODY COLOUR

HUMAN PERCEPTION

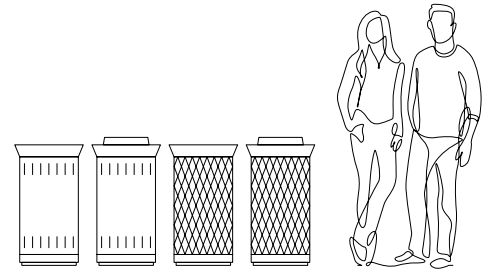

OPENING AND RING DETAIL – LSN 02D 7016



LAUSANNE DEPLOYÉ DETAIL – LSN 02D

Vevey

RECYCLING

bybaumgartner

A minimalist recycling container, which seeks to break the monotony with its asymmetric geometry, commanding your attention from the first glance. In addition, it travels flat packed for very easy assembly.

Un contenedor de reciclaje minimalista, que busca romper con la monotonía con su geometría asimétrica, así es cómo llamará tu atención desde el primer golpe de vista. Además, viaja desmontada y es de muy fácil montaje.

Un conteneur de recyclage minimaliste, qui cherche à rompre la monotonie avec sa géométrie asymétrique, voilà comment il attirera votre attention dès le premier regard. En outre, il voyage démonté et est très facile à assembler.







More about Vevey

DESIGNER
bybaumgartner

YEAR
2018

LINE SKETCH

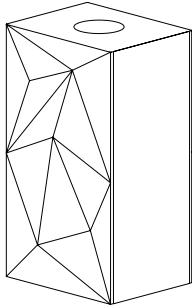

SCALE 1:20 (cm)

PRODUCT

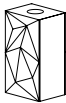

REFERENCE
VVY 01

SIZE
41 x 34 x 73 cm — 86 L
16,1 x 13,4 x 28,7 in. — 22,7 gal.

DETAILS



INTERIOR STRUCTURE DETAIL



EASY TO OPEN LID

RECYCLING

COLOURS

○ RAL 9003

VINYL COLOURS

- BLUE
- GREEN
- YELLOW
- GREY
- BROWN
- RED

CUSTOMISE OPTIONS

- COLOUR
- PICTOGRAMS

HUMAN PERCEPTION

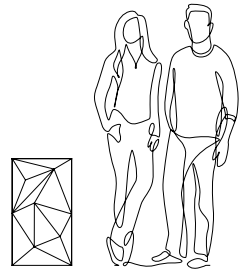

SIMPLE MOUNTING SYSTEM



IDEAL TO CREATE A VISUALLY ATTRACTIVE RECYCLING POINT

Berna

RECYCLING

by Stone Designs

White columns that change, thanks to their coloured lids, in a stylised and harmonic recycling set with great capacity, ideal for commercial and office environments. The inclined hinged lid prevents odours escaping. Choose between two sizes and types of waste pictograms.

Columnas blancas que se convierten, gracias a sus tapas de color, en un conjunto de reciclaje estilizado y armónico de gran capacidad, ideal para espacios contract y oficinas. La tapa abatible inclinada evita que se depositen residuos y que salgan los olores. Elige el tamaño entre dos y el residuo que necesitas.

Colonnes blanches qui deviennent, grâce à leurs couvercles de couleur, un ensemble de recyclage de style et harmonieux, de grande capacité, idéal pour le confort et les espaces de travail. Le couvercle à charnière incliné empêche le dépôt de résidus et l'émission d'odeurs. Choisissez une taille et le type de résidu dont vous avez besoin.







More about Berna

DESIGNER
Stone Designs

YEAR
2014

LINE SKETCH

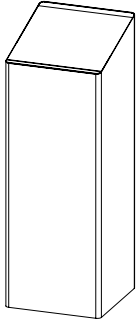

SCALE 1:20 (cm)

PRODUCT



REFERENCE

BER 02 T

SIZE

25 x 25 x 70 cm — 39,4 L
9,8 x 9,8 x 27,6 in. — 10,5 gal.

BER 03 T

35 x 35 x 100 cm — 100 L
13,8 x 13,8 x 39,4 in. — 26,4 gal.

DETAILS







LID DETAIL — BER 03 T 9003 + 3027





BAG RING DETAIL — BER 02 T 9003 + 5012

RECYCLING

COLOURS

-  RAL 9003 + 3027
-  RAL 9003 + 1023
-  RAL 9003 + 6016
-  RAL 9003 + 5012
-  RAL 9003 + 8025

CUSTOMISE OPTIONS

-  COLOUR
-  PICTOGRAMS
-  HOLE ON LID

HUMAN PERCEPTION

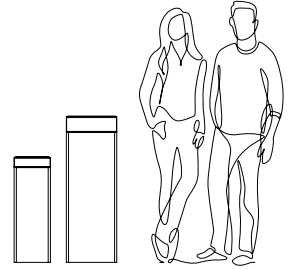

BERNIA FAMILY

Zurich

RECYCLING

by Joan Gaspar

Sobriety and elegance with an architectural air. This recycling bin is ideal for any public space and offices with character. Made from sheet metal. It has a top opening and polycarbonate injection lid, and a metal lid with the larger size.

Sobriedad y elegancia con un aire arquitectónico. Este contenedor de reciclaje es ideal para espacios y oficinas con carácter. Fabricado en plancha metálica. Dispone de apertura superior y tapa de inyección de polycarbonato y tapa metálica en la versión de gran tamaño.

Sobriété et élégance avec un air architectural. Ce bac de recyclage est idéal pour les espaces et les bureaux de caractère. Fabriqué en métal, il est doté d'une ouverture supérieure, d'un couvercle d'injection de polycarbonate et d'un couvercle en métal dans sa version la plus grande.

FLOOR

4

411 —————>

429

<————— 430

449

Organic

Inorganic





More about Zurich

DESIGNER
Joan Gaspar

YEAR
2010 / 2014

LINE SKETCH

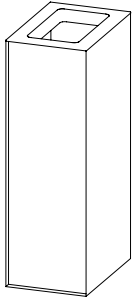

SCALE 1:20 (cm)

PRODUCT



REFERENCE

ZUR 01

SIZE

24 x 35 x 71 cm — 55 L
9,4 x 13,8 x 28 in. — 14,5 gal.

ZUR 02

24 x 35 x 40 cm — 30 L
9,4 x 13,8 x 15,7 in. — 7,9 gal.

ZUR 03

39 x 29 x 98 cm — 110 L
15,4 x 11,4 x 38,6 in. — 29,1 gal.

ZUR 50

28,5 x 21,5 x 69,4 cm — 40 L
11,2 x 8,5 x 27,3 in. — 10,6 gal.

DETAILS



BAG HOLDER AND RING LID OPENING DETAIL — ZUR 03 + 9006



DETAIL LID — ZUR 03 + 9006

RECYCLING

COLOURS

- RAL 9006
- INOX
- RAL 1023
- RAL 5012
- RAL 6016

CUSTOMISE OPTIONS

- COLOUR
- PICTOGRAMS
- HOLE ON LID

HUMAN PERCEPTION

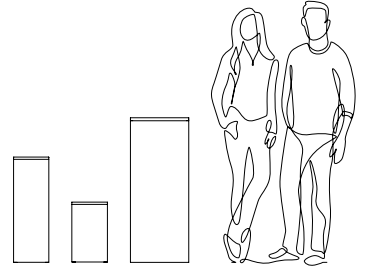

CUSTOMISED WITH VINYL GRAPHICS – ZUR 02

BAG HOLDER AND RING LID OPENING DETAIL – ZUR 01 + 1023

Basilea

RECYCLING

by Pep Puerto

The simplest solution, metal construction, allows the use of colour and pictograms to choose the required types of waste. Includes an inner recycled plastic bin and handles for easy emptying, now also available with front sliding opening.

La solución más simple, de construcción metálica, permite mediante el color y pictograma elegir los residuos deseados. Incluye una cubeta y unas asas para su cómodo vaciado, ahora también disponible una versión con apertura frontal.

La solution la plus simple, de fabrication métallique, elle permet au travers de la couleur et du pictogramme de choisir les types de déchets souhaités. Comprend un seau interne en plastique et des poignées pour une vidange facile. Une version avec ouverture frontale est également disponible.







More about Basilea

DESIGNER
Pep Puerto

YEAR
2015 / 2018

LINE SKETCH

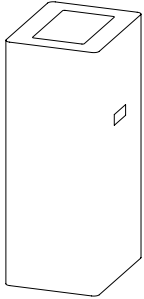

SCALE 1:20 (cm)

PRODUCT

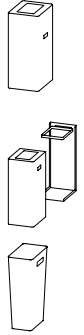

REFERENCE

BAS 01

SIZE

24 x 35 x 70 cm — 40 L
9,4 x 13,8 x 27,6 in. — 10,6 gal.

BAS 10

27 x 35 x 71 cm — 55 L
10,6 x 13,8 x 27,9 in. — 14,5 gal.

ZUR 50

28,5 x 21,5 x 69,4 cm — 40 L
11,2 x 8,5 x 27,3 in. — 10,6 gal.

DETAILS



SET OF CONTAINERS WITH FRONT EXTRACTION SLIDING SYSTEM — BAS 10

RECYCLING

COLOURS

RAL 9003 + 7016

VINYL COLOURS

- BLUE
- GREEN
- YELLOW
- GREY
- BROWN
- RED

CUSTOMISE OPTIONS

- COLOUR
- PICTOGRAMS

HUMAN PERCEPTION

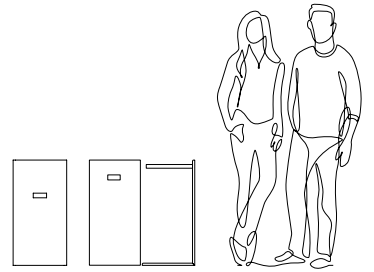

LATERAL HANDLE — BAS 01 / 10
INNER BINS AND UPPER EXTRACTION SYSTEM — BAS 01 + ZUR 50 (INCLUDED)



BASIC RECYCLING POINT — BAS 01

Zell

RECYCLING

by Estudi Ribaudí

Separate three to five types of waste with this recycling station. It's perfect rectangular lines integrating beautifully in any environment. Almost going unnoticed.

Separa los residuos, de tres o cinco tipos, con este contenedor de reciclaje. Sus líneas rectangulares perfectas se integrarán totalmente en tu espacio, llegando a pasar casi desapercibido.

Séparez les déchets, de trois ou cinq types, avec ce bac de recyclage. Ses lignes rectangulaires parfaites s'intégreront totalement à votre espace, arrivant presque à passer inaperçues.







More about Zell

DESIGNER
Estudi Ribaudí

YEAR
2015

LINE SKETCH

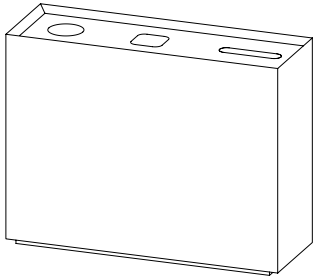

SCALE 1:25 (cm)

PRODUCT

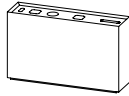

REFERENCE

ZEL 03 / 03P

SIZE

95 x 32 x 75 cm — 120 L
37,4 x 12,6 x 29,5 in. — 31,7 gal.

P: Door version

ZEL 05

125 x 32 x 75 cm — 160 L
49,2 x 12,6 x 29,5 in. — 42,3 gal.

ZUR 50

28,5 x 21,5 x 69,4 cm — 40 L
11,2 x 8,5 x 27,3 in. — 10,6 gal.

ZEL 03 + 3 x ZUR 05 Included (Not 03P)
ZEL 05 + 4 x ZUR 05 Included

DETAILS



RECYCLING STATION FOR FIVE TYPES OF WASTE. INNER BIN DETAIL — ZEL 05

RECYCLING

COLOURS

○ RAL 9003

● INOX

CUSTOMISE OPTIONS

● COLOUR

📄 PICTOGRAMS

↕ HEIGHT & WIDTH

⊖ HOLE ON LID

HUMAN PERCEPTION

VINYL COLOURS

● BLUE

● GREY

● GREEN

● BROWN

● YELLOW

● RED

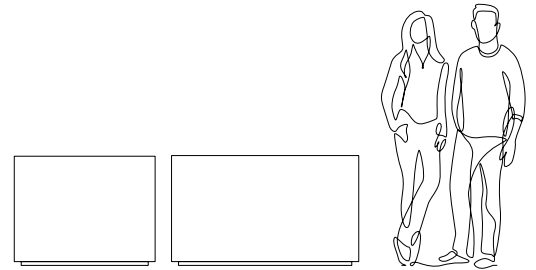

RING TO HOLD BAG AND DOORS FOR FRONTAL EXTRACTION SYSTEM DETAIL – ZEL 03P



LID AND COLOURED GRAPHICS FOR TYPES OF WASTE – ZEL 03

Interlaken

RECYCLING

by Plumartis

A set of recycling containers that will enhance any interior, attracting the attention of passersby. Made of lacquered sheet metal, with a removable top, colour and shape will determine which types of waste.

Un conjunto de contenedores de reciclaje que vestirá cualquier espacio, atraerá la vista de quien pase por delante por su simpatía. Fabricado en chapa de acero lacada, con un cabezal extraíble, de color y forma que determinará el residuo.

Un ensemble de conteneurs de recyclage qui habillera n'importe quel espace, attirera la vue de ceux qui passent par leur sympathie. Fabriqué en tôle d'acier laquée, avec un couvercle amovible, une couleur et une forme qui détermineront le résidu.







More about Interlaken

DESIGNER
Plumartis

YEAR
2019

LINE SKETCH

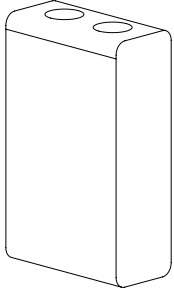

SCALE 1:20 (cm)

PRODUCT

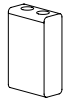

REFERENCE

INT 01 A/B/C/D

SIZE

40 x 20 x 35 cm — 24,7 L
17,7 x 7,9 x 13,8 in. — 6,5 gal.

INT 02 A/B/C/D

40 x 20 x 45 cm — 32,7 L
17,7 x 7,9 x 17,7 in. — 8,6 gal.

INT 03 A/B/C/D

40 x 20 x 55 cm — 40,7 L
17,7 x 7,9 x 21,7 in. — 10,8 gal.

INT 04 A/B/C/D

40 x 20 x 65 cm — 48,7 L
17,7 x 7,9 x 25,6 in. — 12,9 gal.

LID OPTIONS

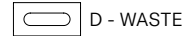
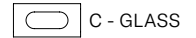
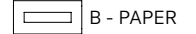
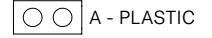



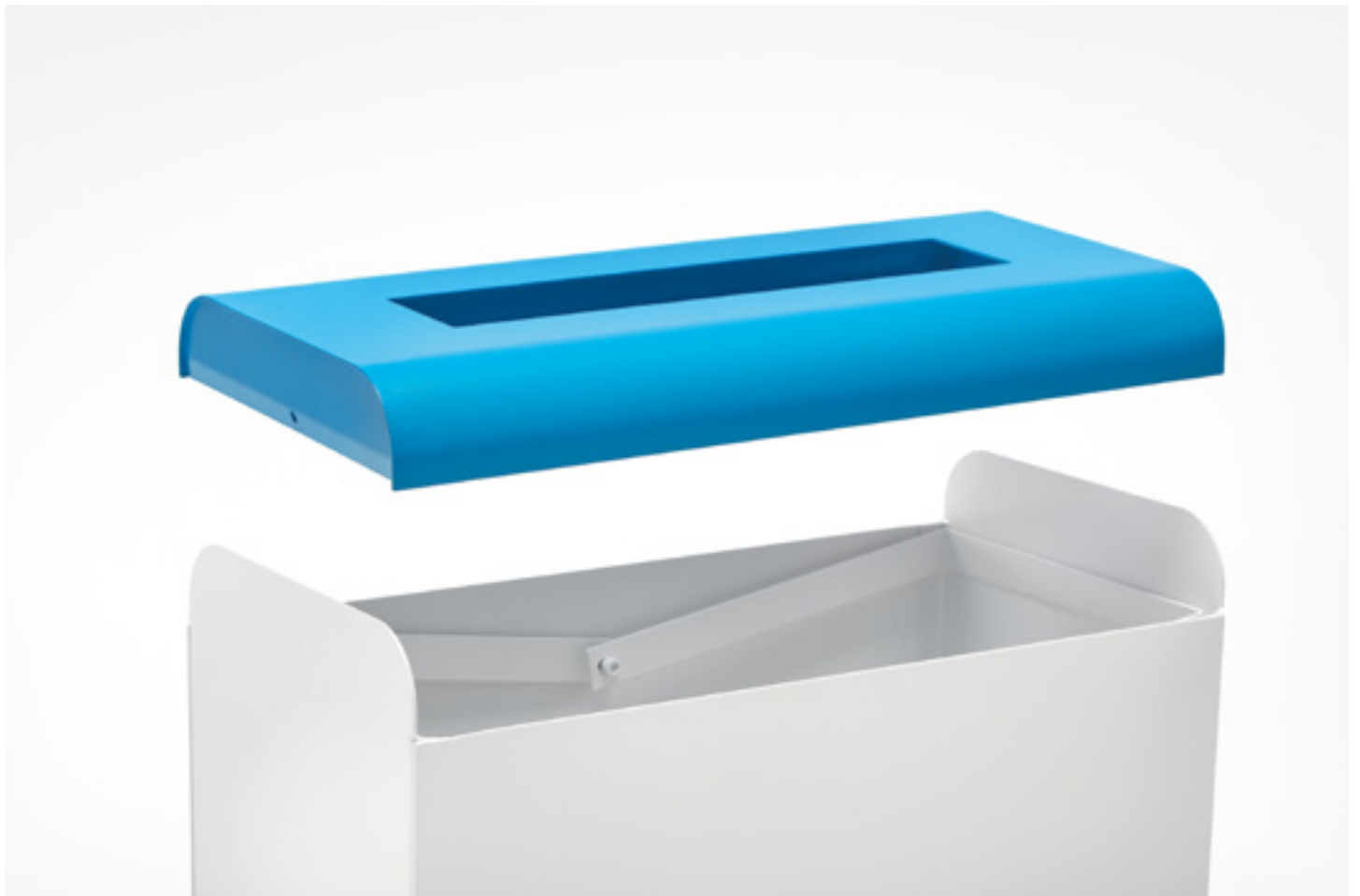

DETAILS



BIN LID EXTRACTION DETAIL — INT 03 C

RECYCLING

COLOURS

-  RAL 9003 + 1023
-  RAL 9003 + 6016
-  RAL 9003 + 5012
-  RAL 9003 + 8025

CUSTOMISE OPTIONS

-  COLOUR
-  HOLE ON LID

HUMAN PERCEPTION



BAG RING DETAIL — INT 03



INTERLAKEN FAMILY

Baden

RECYCLING

by Roger Vancells

A robust, high-capacity bin ideal for public areas. Large opening with a practical door for emptying and maintenance. Also available with an ashtray on top.

Una papelera robusta, de gran capacidad que es ideal para espacios públicos. Boca de gran tamaño con una práctica puerta para su vaciado y mantenimiento. Disponible versión con cenicero en su parte superior.

Une corbeille à papier robuste et de grande capacité, idéale pour les espaces publics. Grande ouverture avec une porte pratique pour sa vidange et sa maintenance. Version disponible avec cendrier sur le dessus.





WAY
8
7

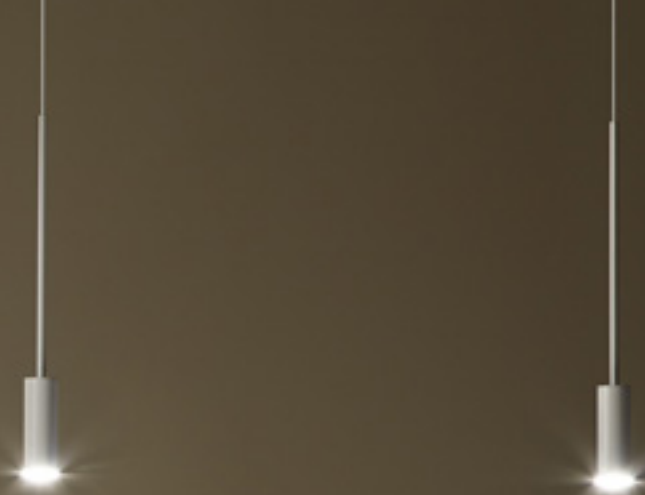

More about Baden

DESIGNER
Roger Vancells

YEAR
2017

LINE SKETCH

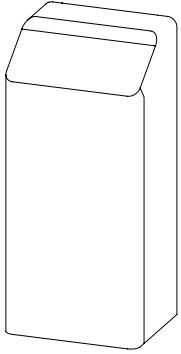

SCALE 1:20 (cm)

PRODUCT

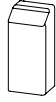

REFERENCE
BDN 01

SIZE
45 x 35,5 x 100 cm — 100 L
17,7 x 14 x 39,3 in. — 26,4 gal.

DETAILS

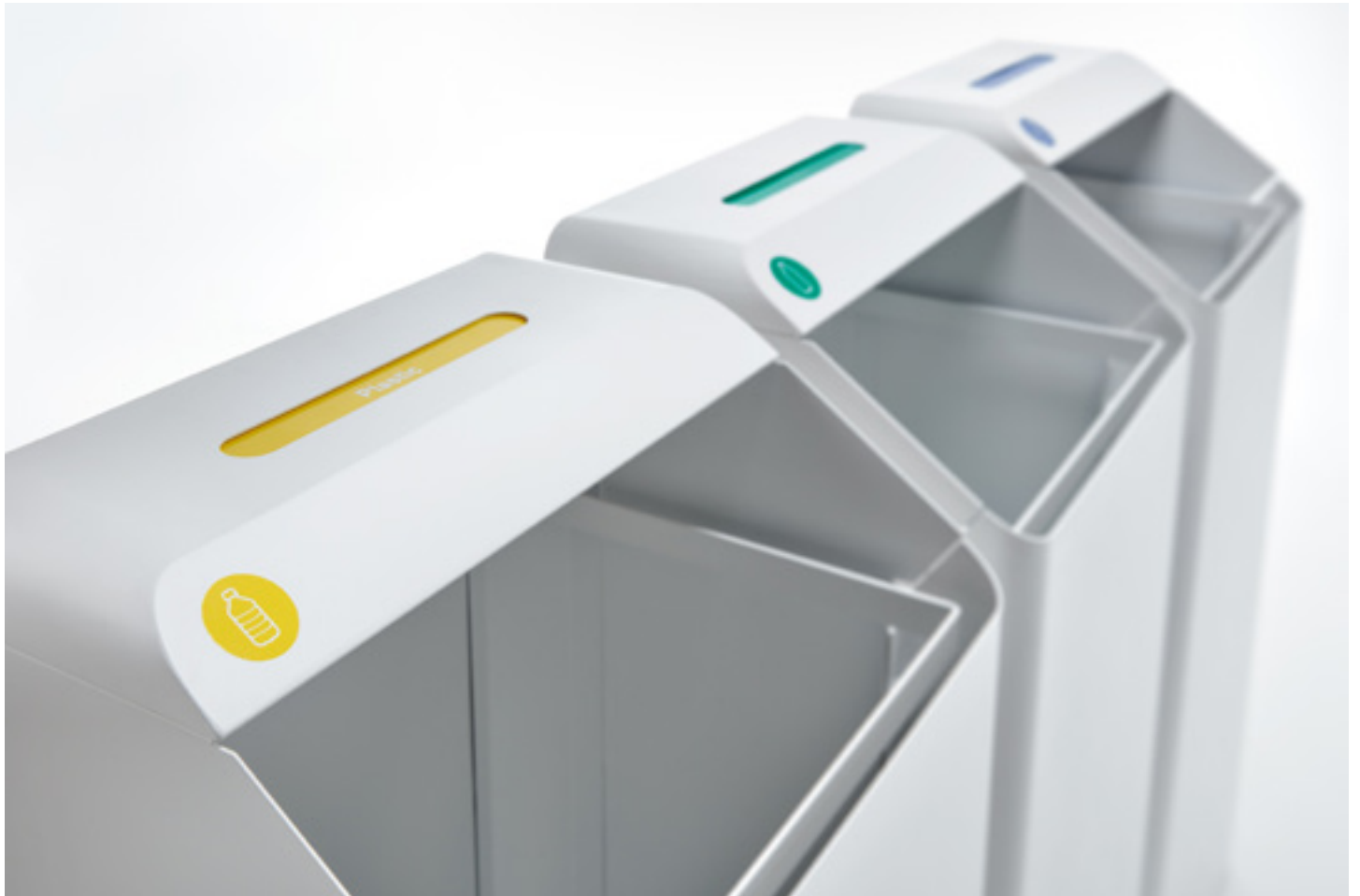

LARGE CAPACITY RECYCLING POINT — BDN 01

RECYCLING

COLOURS

○ RAL 9003

● RAL 7016

CUSTOMISE OPTIONS

● COLOUR

📄 PICTOGRAMS

VINYL COLOURS

● BLUE

● GREY

● GREEN

● BROWN

● YELLOW

● RED

HUMAN PERCEPTION

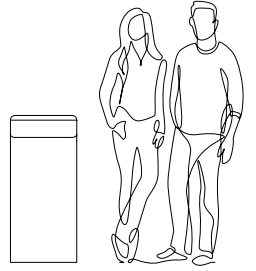

SUPERIOR LID WITH WASTE IDENTIFIER – BDN 01

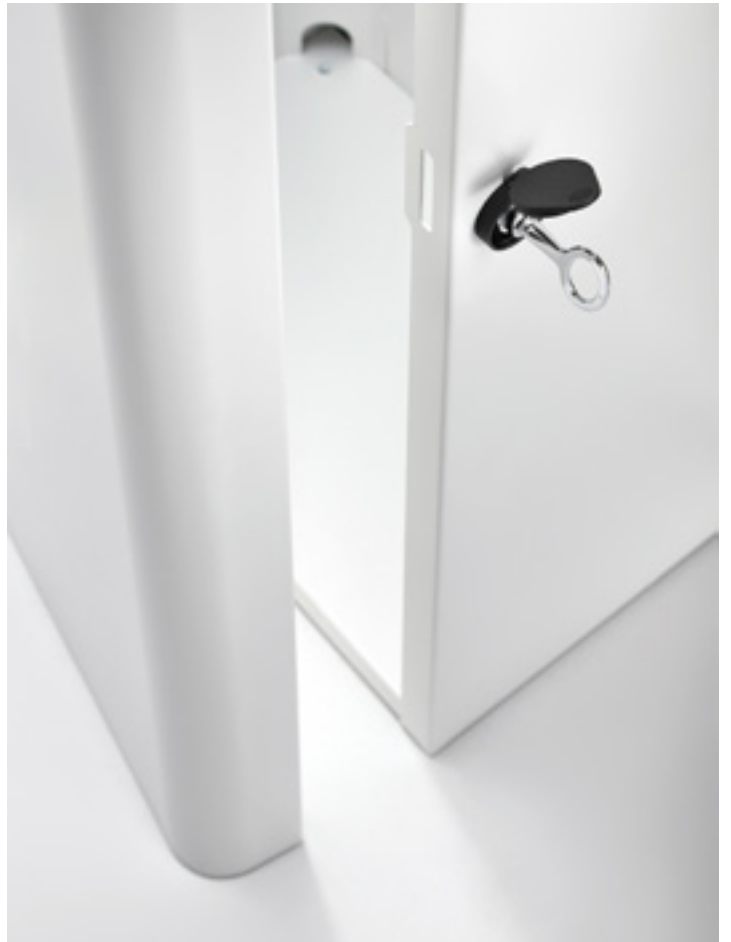

LOCK DETAIL – BDN 01

Baden + SB_system

by Grup Idea

SB_system is a tool for the management of large capacity recycling bins at the maintenance and security levels, by providing them with an electronic device that allows their monitoring via a Wi-Fi connection. We obtain the information required to generate alerts and store data, which can be accessed by authorized personnel through Android App or the SB_system website.

SB_system es una herramienta para la gestión de papeleras de gran capacidad a nivel de mantenimiento y seguridad, al dotarlas de un dispositivo electrónico que permite su monitorización mediante conexión Wi-Fi. Obtenemos la información requerida para generar alertas y almacenar datos, a los que puede acceder el personal autorizado mediante la App Android o web de SB_system.

SB_system est un outil de gestion de la maintenance et de la sécurité des corbeilles de grande capacité, en leurs fournissant un dispositif électronique qui permet leur surveillance via une connexion Wi-Fi. Nous obtenons les informations nécessaires pour générer des alertes et stocker des données auxquelles le personnel autorisé peut avoir accès via l'application Android ou le site web SB_system.

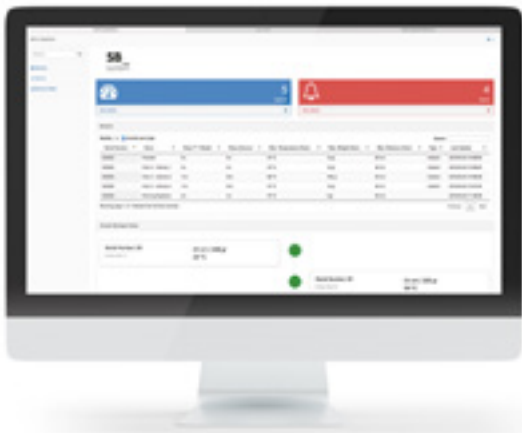

SB_SYSTEM WEBSITE



SB_SYSTEM ANDROID APP

Weight

The weight alarm is activated when the sensor detects an abrupt change, which could suggest that an unusual object has been deposited, causing the activation of the corresponding security protocol.

La alarma de peso se activa cuando el sensor detecta un cambio abrupto, lo que podría sugerir que se ha depositado un objeto extraño, provocando la activación del protocolo de seguridad correspondiente.

L'alarme de poids est activée lorsque le capteur détecte un changement brusque, ce qui pourrait suggérer le dépôt d'un objet suspect, provoquant ainsi l'activation du protocole de sécurité correspondant.

Capacity

A distance sensor can determine the maximum acceptable level, and inform maintenance personnel to empty the bag. It also helps determine the areas where there is greater demand and greater capacity is needed.

Un sensor de distancia puede determinar el nivel máximo aceptable, e informar al personal de mantenimiento para cambiar la bolsa. También ayuda a determinar las áreas donde hay mayor demanda y se necesita mayor capacidad.

Un capteur de distance peut déterminer le niveau maximum acceptable de remplissage et ainsi informer le personnel de maintenance de changer le sac ou pas. Cela aide également à déterminer les zones où la demande est la plus forte et où une plus grande capacité sera éventuellement nécessaire.

Temperature

SB_system has a thermometer that allows it to monitor the temperature inside the bin, the alarm is activated when it exceeds the maximum acceptable limits which follows a situation of risk or a possible fire.

SB_system cuenta con un termómetro que permite monitorizar la temperatura en la papelera, la alarma se activa cuando supera los límites máximos aceptables lo cual sugiere una situación de riesgo o un posible incendio.

SB_system dispose d'un thermomètre qui permet de contrôler la température dans le bac, l'alarme est activée lorsqu'elle dépasse les limites maximales préalablement configurées et prévient ainsi d'une situation de risque ou d'un éventuel incendie.



Lugano

RECYCLING

by CrousCalogero

Imagine not having to bend over to dispose of waste. We have raised the bin to table height. A great idea, so that in large offices the bin can be emptied effortlessly by the cleaning team.

Imagina no tener que agacharte para dejar algo en la papelera. Hemos elevado la papelera a la altura de la mesa, pero sin que moleste. Una idea genial, incluso para que en oficinas grandes el vaciado no pase factura al personal de limpieza. Y además, ¡es divertida!

Imaginez ne pas avoir à vous pencher pour laisser quelque chose à la poubelle. Nous avons élevé le bac à la hauteur de la table, mais sans qu'il nous gêne. Une idée géniale, qui facilitera le travail du personnel de nettoyage dans les grands espaces de bureaux. En plus elle est amusante !







More about Lugano

DESIGNER
CrousCalogero

YEAR
2014

LINE SKETCH

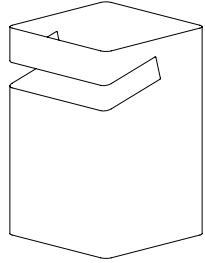

SCALE 1:10 (cm)

PRODUCT



REFERENCE
LUG 01

SIZE
18,8 x 18,8 x 30 cm — 8 L
7,4 x 7,4 x 11,8 in. — 2,1 gal.

DETAILS



DESK FIXING DETAIL — LUG 01

RECYCLING

COLOURS

○ RAL 9003

CUSTOMISE OPTIONS

● COLOUR

📄 PICTOGRAMS

HUMAN PERCEPTION

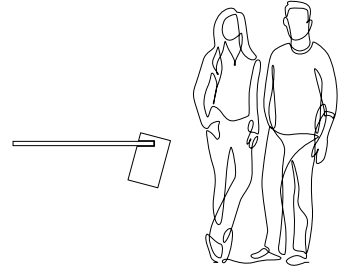

SUITABLE FOR DESKS UP TO 35 MM THICKNESS – LUG 01



MINI-BIN DETAIL – LUG 01

Ginebra

RECYCLING

by Pascual Salvador

A litter bin with multiple personalities. Simple and with a friendly aesthetic which is available in three different options allowing you to choose one or two types of waste. It's metal base and its colourful polypropylene body with the flexibility to resist possible impacts.

Una papelera con multipersonalidad. Simple y con una estética amable está disponible en tres modelos distintos, para que elijas si quieres para uno o dos residuos. Su base metálica permite recoger líquidos ocasionales y su colorido cuerpo de polipropileno, le da la flexibilidad necesaria para resistir posibles impactos.

Une corbeille à personnalité multiple. Simple et esthétique, trois modèles différents sont disponibles. Vous pouvez donc choisir si vous le souhaitez pour un ou deux types de déchets. Sa base en métal vous permet de collecter des liquides occasionnels et son corps coloré en polypropylène vous offrira la flexibilité nécessaire pour résister aux chocs éventuels.







More about Ginebra

DESIGNER
Pascual Salvador

YEAR
2010

LINE SKETCH

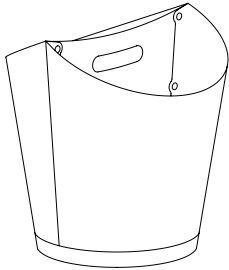

SCALE 1:10 (cm)

PRODUCT



REFERENCE

GIN 01

SIZE

Ø33 x 43 cm — 18 L
Ø13 x 16,9 in. — 4,8 gal.

GIN 02

Ø33 x 34 cm — 10 + 10 L
Ø13 x 13,4 in. — 2,6 + 2,6 gal.

GIN 03

Ø33 x 34 cm — 6 + 13 L
Ø13 x 13,4 in. — 1,6 + 3,4 gal.

DETAILS



GINEBRA FAMILY IN THREE DIFFERENT DESIGNS — GIN 01 P208 + GIN 02 P440 + GIN 03 P100

RECYCLING

COLOURS

- BL · PLAKENE · P000
- AZ · PLAKENE · P100
- VD · PLAKENE · P208
- NJ · PLAKENE · P440
- AM · PLAKENE · P706

CUSTOMISE OPTIONS

- COLOUR

HUMAN PERCEPTION

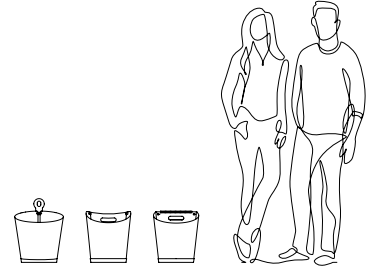

GIN 03 P208
GIN 03 P440

GIN 01 P100
GIN 02 P706

Biel

RECYCLING

by Ximo Roca Diseño

Down with boring offices!
This perhaps is the most fun wastebasket in the world ... for under desk use, made with injected plastic and available in four colours. If you prefer non-standard colours tell us and we can personalise the colour and logo.

¡Basta de oficinas aburridas! Quizás sea la papelera más divertida del mundo... papelera de bajo mesa inyectada en plástico y disponible en cuatro colores. Si no te gustan nuestros colores, puede fabricarse en colores especiales e incluso personalizarse con un logo.

Assez des bureaux ennuyeux ! C'est peut-être la poubelle la plus drôle au monde ... une corbeille à papier injectée en plastique et disponible en quatre couleurs. Si vous n'aimez pas nos couleurs, vous pouvez la personnaliser et même la personnaliser avec un logo.







More about Biel

DESIGNER

Ximo Roca Diseño

YEAR

2016

LINE SKETCH

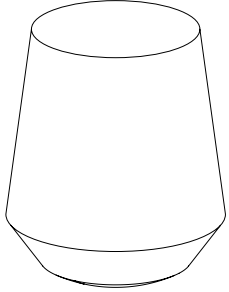

SCALE 1:10 (cm)

PRODUCT



REFERENCE

BIE 01

SIZE

Ø30 x 36 cm — 18 L
Ø11,8 x 14,2 in. — 4,8 gal.

DETAILS



BASE DETAIL, WHICH MAKES THE PAPER BASKET OSCILLATE, WITHOUT FALLING OVER — BIE 01 2003

RECYCLING

COLOURS

-  RAL 9003
-  RAL 2003
-  RAL 5012
-  RAL 9011

CUSTOMISE OPTIONS

-  COLOUR
-  LOGOTYPE

HUMAN PERCEPTION

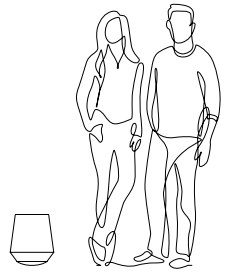

BIEL FAMILY

Laax

RECYCLING

by Stone Designs

This outdoor ashtray will modernise the rest areas of any exterior or interior patio. Manufactured in epoxy painted iron and treated with cataphoresis, it will resist any inclemency in the weather. It's very simple and easy to clean.

Este cenicero modernizará las zonas de descanso exterior de un edificio o una gran superficie. Fabricado en hierro pintado epoxi y tratado con cataforesis, resistirá a la intemperie a cualquier inclemencia del tiempo. Además, tiene un sistema de vaciado y limpieza muy simple.

Ce cendrier modernisera les aires de repos extérieures d'un bâtiment ou d'une grande surface. Fabriqué en fer peint à l'époxy et traité par cataphorèse, il résistera aux intempéries de toutes les intempéries. De plus, il dispose d'un système de vidange et de nettoyage très simple.







More about Laax

DESIGNER
Stone Designs

YEAR
2016

LINE SKETCH

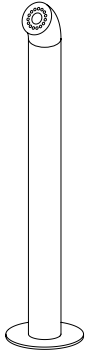

SCALE 1:20 (cm)

PRODUCT



REFERENCE
LAX 01

SIZE
Ø21 x 100 cm
Ø8,3 x 39,4 in.
Tube: Ø8,8 cm / Ø3,4 in.

DETAILS



ASHTRAY TOP REMOVABLE – LAX 01



DETAIL OF UPPER LID – LAX 01 + 9006

RECYCLING

COLOURS

- RAL 9003
- RAL 9006
- RAL 7016

CUSTOMISE OPTIONS

- COLOUR

HUMAN PERCEPTION

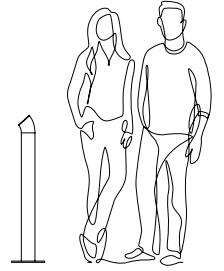

LAAX FAMILY

Comfort

Treviso	104
Bergamo	110
Milano	116
Capri	122
Siena	128
Bologna	134
Padova	140
Torino	146
Napoli	152
Bamboo	158
Note-it	164
Vevey Acoustic	170
Kyoto	176
Sapporo	182
Adelaida	188
Albury	194
Nagoya	200
Osaka	206
Menfis	212

Treviso

COMFORT

by NutCreatives

Wall hanger made of natural beech varnished or painted. Five irregular pieces of wood made from a single block. Play by placing it at your whim on the wall and it will be ready to hang wherever you like.

Colgador mural de madera de haya natural barnizada o pintada. Cinco piezas irregulares generadas a partir de un único bloque. Juega colocándolo a tu antojo en la pared y estará listo para colgar lo que necesites.

Patère murale en hêtre naturel verni ou peint. Cinq pièces irrégulières générées à partir d'un seul bloc. Jouez en les plaçant à votre guise sur le mur, ils seront prêts pour suspendre ce dont vous avez besoin.



Finalista Delta
Premios ADI
2016





↳ Sarah

↳ Bruce

↳ Celine

↳ Mark

↳ Liz





More about Treviso

DESIGNER
NutCreatives

YEAR
2015

LINE SKETCH

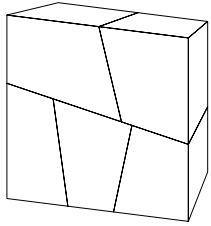

SCALE 1:5 (cm)

PRODUCT



REFERENCE

TRE 01

SIZE

11 x 11 x 6 cm
4,3 x 4,3 x 2,4 in.

Wood and colours version

TRE 02

11 x 11 x 6 cm
4,3 x 4,3 x 2,4 in.

Wood version

DETAILS



DETAIL OF THE HANGERS – TRE 01

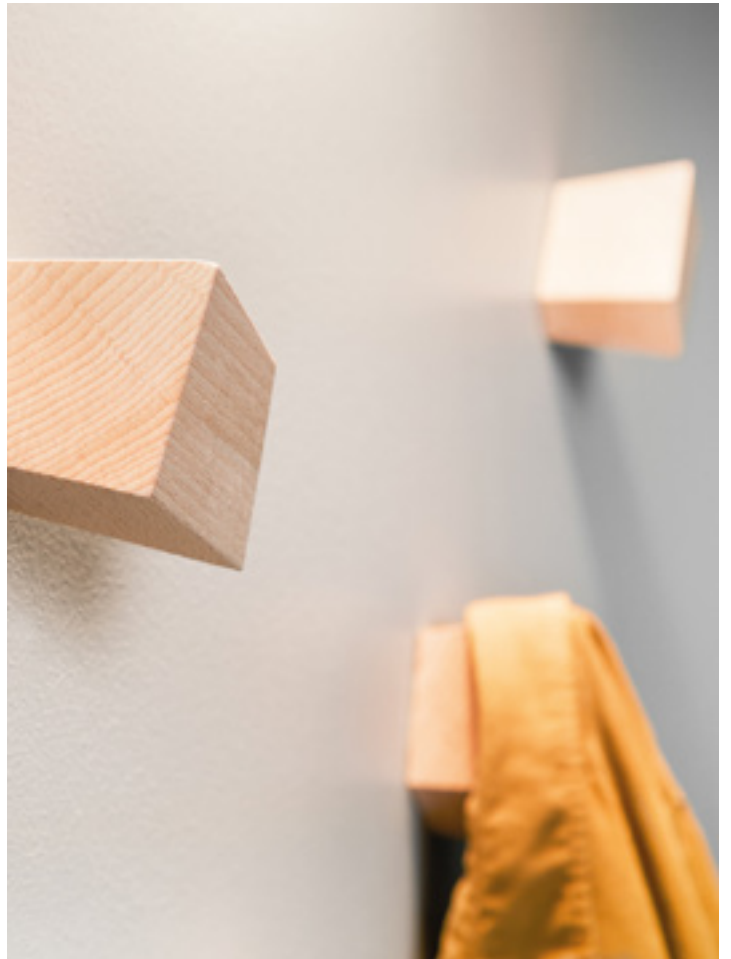

DETAIL OF THE HANGERS – TRE 02

COMFORT

COLOURS

 WOOD + COLOUR

 WOOD

CUSTOMISE OPTIONS

 COLOUR

HUMAN PERCEPTION

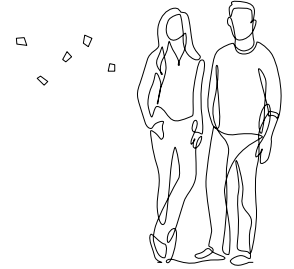

TREVISO SET DETAIL – TRE 01

Bergamo

COMFORT

by La Mamba Studio

Wall mounted or in a rack with four hooks and a functional upper shelf, this coat rack adapts to your needs. A fusion of metal and beech wood that combine perfectly.

De pie, en la pared o en rack de cuatro colgadores y una funcional repisa superior, este perchero se adapta a lo que necesitas para tu espacio. Una fusión de metal y madera de haya que combina a la perfección.

Debout, au mur ou dans un rack avec quatre patères et une étagère supérieure fonctionnelle, ce portemanteau s'adapte à tout ce dont vous avez besoin pour votre espace. Une fusion du métal et du bois de hêtre qui se combine à la perfection.







More about Bergamo

DESIGNER
La Mamba Studio

YEAR
2016 / 2019

LINE SKETCH

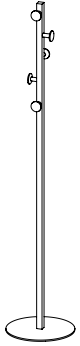

SCALE 1:40 (cm)

PRODUCT

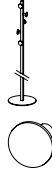
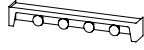

REFERENCE

BRG 01

SIZE

70 x 10 x 10 cm
4,6 x 3,9 x 3,9 in.

BRG 10

Ø36 x 180 cm
Ø14,2 x 70,9 in.

BRG M

Ø5,5 x 5,5 cm
Ø2,2 x 2,2 in.

Only in wood

DETAILS



SHELF WITH RACK – BRG 01 9003

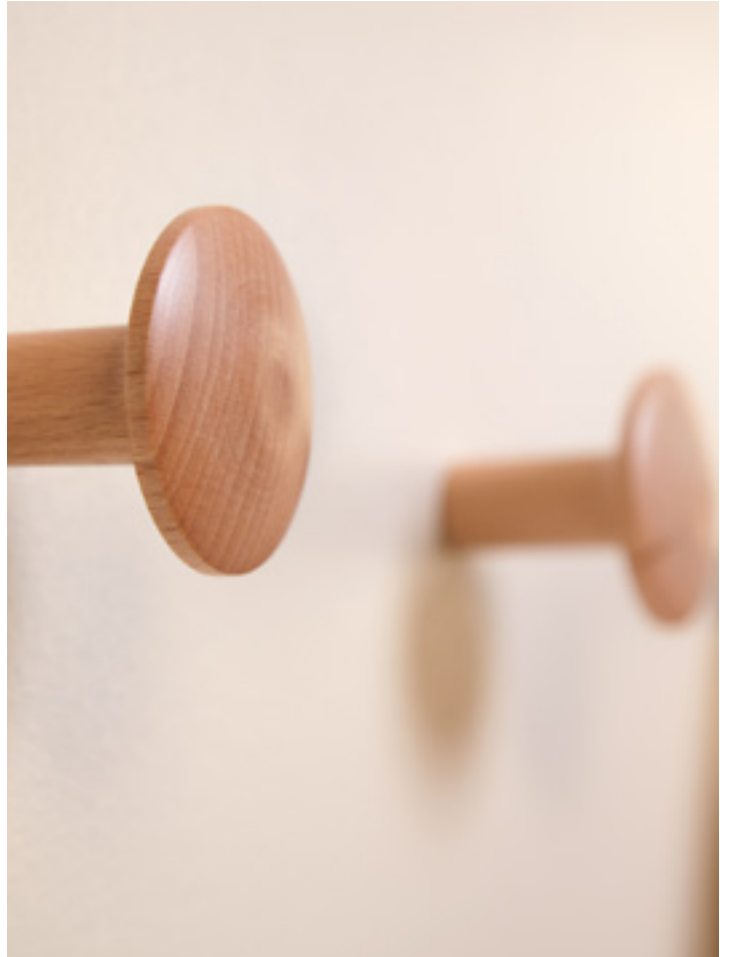



WALL MOUNTED VERSION – BRG M

COMFORT

COLOURS

-  RAL 9003
-  RAL 2004
-  RAL 7016
-  WOOD

CUSTOMISE OPTIONS

-  COLOUR
-  NUMBER OF HANGERS

HUMAN PERCEPTION

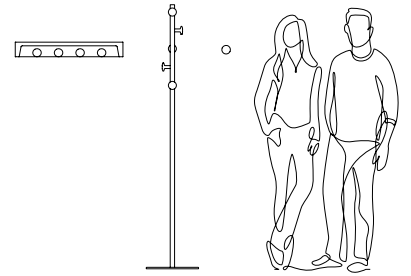

COAT RACK CLOSE UP – BRG 10 7016

Milano

COMFORT

by Roger Vancells

Choose how to add warmth to your project with this original designer coat stand. A silhouette of beech wooden curved slats in two versions; three or six slats as well as mini metal wall hangers.

Elige cómo añadir a tu espacio calidez con este original perchero de diseño. Una silueta de lamas de madera de haya curvadas en dos versiones; tres o seis lamas, y también una mini lama metálica ideal para pared.

Choisissez comment ajouter de la chaleur à votre espace avec ce porte-manteau de design original. Une silhouette conçue de lattes en bois de hêtre courbées en deux versions ; trois ou six lattes, et aussi une mini patère en métal idéale pour le mur.







More about Milano

DESIGNER
Roger Vancells

YEAR
2015 / 2018

LINE SKETCH

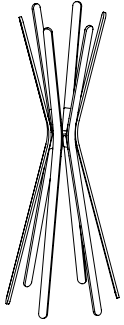

SCALE 1:40 (cm)

PRODUCT



REFERENCE

MIL 03

SIZE

Ø61 x 165 cm
Ø24 x 65 in.

MIL 06

Ø61 x 165 cm
Ø24 x 65 in.

MIL 16

5 x 10 x 34,4 cm
2 x 3,9 x 13,5 in.

Only available in metal

DETAILS



COAT RACK CLOSE UP — MIL 06 WOOD



CENTRAL UNIFIER FOR THREE SPINES CLOSE UP — MIL 03 7016
CENTRAL UNIFIER FOR SIX SPINES CLOSE UP — MIL 06 WOOD

COMFORT

COLOURS

- RAL 9003
- RAL 2004
- RAL 7016
- WOOD

CUSTOMISE OPTIONS

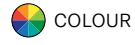

HUMAN PERCEPTION

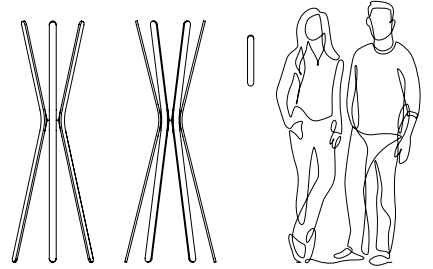

WOODEN SPINE CLOSE UP – MIL 03 WOOD



WALL MOUNTED METAL VERSION – MIL 16 7016

Capri

COMFORT

by Jordi Blasi

Combining the warmth of wooden hangers with a metal post and base. Two, four or six hooks, also available with umbrella stand and a wall mounted version. It is ideal for environments where a touch of warmth is sought.

Combinamos la calidez de sus perchas de madera con el metal de su base y estructura. De dos, cuatro o seis perchas, disponible también en su versión paragüero y una versión mural. Es ideal para espacios donde se busca un toque de calidez.

Nous avons combiné la chaleur de ses patères en bois avec le métal de sa base et de sa structure. Deux, quatre ou six patères, également disponible en version porte-parapluie et version murale. Il est idéal pour les espaces où l'on souhaite apporter une touche de chaleur.







More about Capri

DESIGNER
Jordi Blasi

YEAR
2016

LINE SKETCH

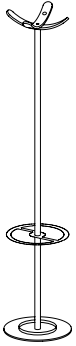

SCALE 1:40 (cm)

PRODUCT



REFERENCE

CPR 01 / 21
CPR 02 / 22
CPR 03 / 23

SIZE

Ø36 x 170 cm
Ø14,2 x 66,9 in.

CPR 12

Ø36 x 50 cm
Ø14,2 x 19,7 in.

CPR 10

5 x 7,7 x 35 cm
2 x 3 x 13,8 in.

Only in wood

CPR 20

5 x 5,7 x 25 cm
2 x 2,2 x 9,8 in.

Only in wood

DETAILS



COAT HANGER — CPR 02 7016 + CPR 10



UMBRELLA STAND — CPR 12 9011

COMFORT

COLOURS

-  RAL 9003 + WOOD
-  RAL 2004 + WOOD
-  RAL 9006 + WOOD
-  RAL 7016 + WOOD

CUSTOMISE OPTIONS

-  COLOUR

HUMAN PERCEPTION

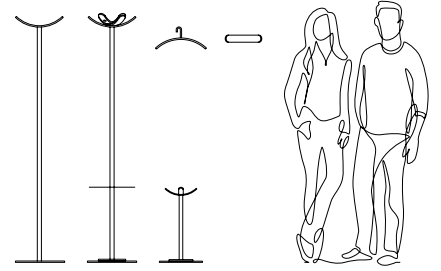

VERTICALLY MOUNTED WALL VERSION — CPR 01 2004 + CPR 20

Siena

COMFORT

by Nahtrang

What if, besides a coat stand it's a signpost. Made from wood with four metal hooks pointing to four different places: The Moon, the Sun, Jupiter and Mercury are the preferred destinations of the standard model, but you can customise them with whatever you want. It is ideal in any environment.

¿Y si además de colgador es un indicador? En madera con cuatro perchas metálicas apuntando a cuatro sitios diferentes: La Luna, el Sol, Júpiter y Mercurio son los destinos preferidos del modelo estándar, pero puedes personalizarlos con lo que quieras. Es ideal en ambientes confort.

Que se passe-t-il si en plus d'une patère, c'est un indicateur ? En bois avec quatre patères métalliques pointant vers quatre endroits différents : la Lune, le Soleil, Jupiter et Mercure sont les destinations préférées du modèle standard, mais vous pouvez les personnaliser comme vous le souhaitez. Il est idéal dans les environnements de confort.







More about Siena

DESIGNER
Nahtrang

YEAR
2015

LINE SKETCH

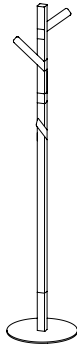

SCALE 1:40 (cm)

PRODUCT



REFERENCE
SIE 01

SIZE
Ø36 x 180 cm
Ø14,2 x 70,9 in.

STANDARD TEXT
THE MOON
THE SUN
MERCURY
JUPITER

DETAILS



COAT RACK WITH STANDARD TEXT – SIE 01 9003

COMFORT

COLOURS

- WOOD + RAL 9003
- WOOD + RAL 2004
- WOOD + RAL 7016

CUSTOMISE OPTIONS

- COLOUR
- txt TEXT

HUMAN PERCEPTION

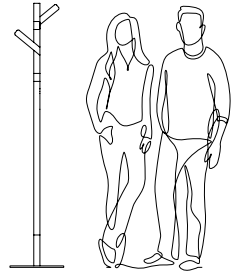

COAT RACK WITH PERSONALISED TEXT — SIE 01 7016

Bologna

COMFORT

by Eduard Juanola

Simple, minimalist and easy to use, it's as if you put some clips on a stand. Made from metal and with five clips in chromed steel that will support even the heaviest backpack, or if you want, with the wooden version you can add warmth to your design. Now you can give your office an original touch!

Sencillo, minimalista y fácil de usar, es cómo si pusieras unos clips a un perchero. Fabricado en metal y con cinco clips en acero cromado que soportaran hasta la mochila más pesada, o si quieres, con la versión en madera podrás darle calidez a tu espacio. ¡Ahora sí que podrás darle un toque original a tu oficina!

Simple, minimaliste et facile à utiliser, c'est comme si vous mettiez des trombones sur un porte-manteau. Fabriqué en métal et doté de cinq patères en acier chromé qui supporteront même le sac à dos le plus lourd, ou si vous le souhaitez, avec la version en bois, vous donnerez de la chaleur à votre espace. Vous pouvez maintenant donner à votre bureau une touche originale !







More about Bologna

DESIGNER
Eduard Juanola

YEAR
2015 / 2018

LINE SKETCH

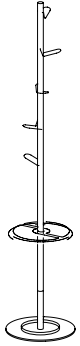

SCALE 1:40 (cm)

PRODUCT

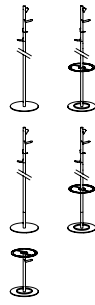

REFERENCE

BOL 01 / 11

SIZE

Ø36 x 180 cm
Ø14,2 x 70,9 in.

BOL 10 / 12

Ø36 x 180 cm
Ø14,2 x 70,9 in.

Wooden version

BOL P

Ø36 x 50 cm
Ø14,2 x 19,7 in.

DETAILS



"CLIP" HANGER – BOL 10

COMFORT

COLOURS

- RAL 9003
- RAL 2004
- RAL 7016

CUSTOMISE OPTIONS

- COLOUR
- ② NUMBER OF HANGERS

- WOOD + RAL 9003
- WOOD + RAL 7016

HUMAN PERCEPTION

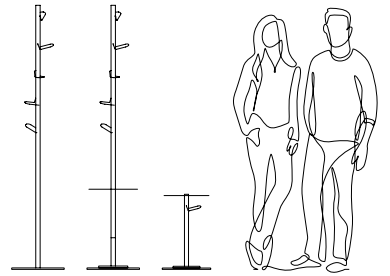

UMBRELLA STAND AND COAT STAND WITH INTEGRATED UMBRELLA HOLDER — BOL P 9003 + BOL 12 9003



COAT STAND

Padova

COMFORT

by Roger Vancells

As Rams said, less is more, this coat stand has been reduced to the minimum expression. With a simple but daring design it has been fused with five hooks injected in colourful plastic on a white lacquered metal base. Now yes, less is more.

Cómo decía Rams, menos es más, este perchero se ha reducido todo a la mínima expresión. Con un diseño sencillo pero atrevido se ha fusionado cinco perchas inyectadas en plástico colorido sobre una base metálica lacada en blanco. Ahora sí, menos es más.

Comme le disait Rams, moins c'est plus, ce porte-manteau a été réduit au minimum. Avec un design simple mais audacieux, cinq patères en plastique injecté de couleur fusionnent avec une base en métal laqué blanche. Maintenant oui, moins c'est plus.







More about Padova

DESIGNER
Roger Vancelli

YEAR
2018

LINE SKETCH

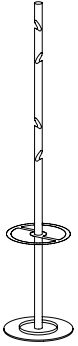

SCALE 1:40 (cm)

PRODUCT



REFERENCE

PDV 01

SIZE

Ø36 x 180 cm
Ø14,2 x 70,9 in.

PDV 10

Ø36 x 180 cm
Ø14,2 x 70,9 in.

PDV P

Ø36 x 50 cm
Ø14,2 x 19,7 in.





DETAILS





HANGER CLOSE UP — PDV 01 7016

COMFORT

COLOURS

-  RAL 9003
-  RAL 9003 + 2004
-  RAL 9003 + 9006
-  RAL 9003 + 7016

CUSTOMISE OPTIONS

-  COLOUR
-  NUMBER OF HANGERS

HUMAN PERCEPTION

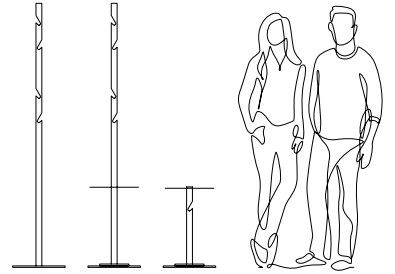

UMBRELLA STAND AND COAT STAND WITH INTEGRATED UMBRELLA HOLDER — PDV P 7016 + PDV 10



COAT STAND CLOSE UP — PDV 01 7016 + PDV 01 2004

Torino

COMFORT

by Eduard Juanola

A coat rack designed for demanding work spaces thanks to six retractable hooks with great resistance. A white metal post and base, combined with hooks that are available in four standard colours. Although, if you want them to match your corporate colour, we can also customise them.

Un perchero pensado para espacios de trabajo exigentes gracias a seis perchas retráctiles de gran resistencia. Con una estructura y base metálica blanca, combinadas con perchas que están disponibles en cuatro colores estándar. Aunque, si quieres que hagan juego con tu color corporativo, también podemos personalizarlas.

Un porte-manteau conçu pour les espaces de travail exigeants grâce à six patères rétractables d'une grande résistance. Avec une structure et une base en métal blanc, associées à des patères disponibles en quatre couleurs standard. Toutefois, si vous souhaitez qu'ils correspondent à la couleur corporative de votre entreprise, nous pouvons également les personnaliser.







More about Torino

DESIGNER
Eduard Juanola

YEAR
2015

LINE SKETCH

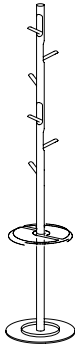

SCALE 1:40 (cm)

PRODUCT



REFERENCE

TRN 05

SIZE
Ø36 x 180 cm
Ø14,2 x 70,9 in.

TRN 15

Ø36 x 180 cm
Ø14,2 x 70,9 in.

TRN P

Ø36 x 50 cm
Ø14,2 x 19,7 in.







DETAILS





HANGER CLOSE UP – TRN 05 9006/9003

COMFORT

COLOURS

-  RAL 9003 + 9003
-  RAL 9003 + 2004
-  RAL 9003 + 7016
-  RAL 9006 + 9003
-  RAL 9006 + 2004
-  RAL 9006 + 7016

CUSTOMISE OPTIONS

-  COLOUR
-  NUMBER OF HANGERS

HUMAN PERCEPTION

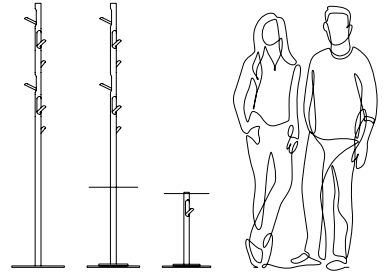

UMBRELLA STAND – TRN P

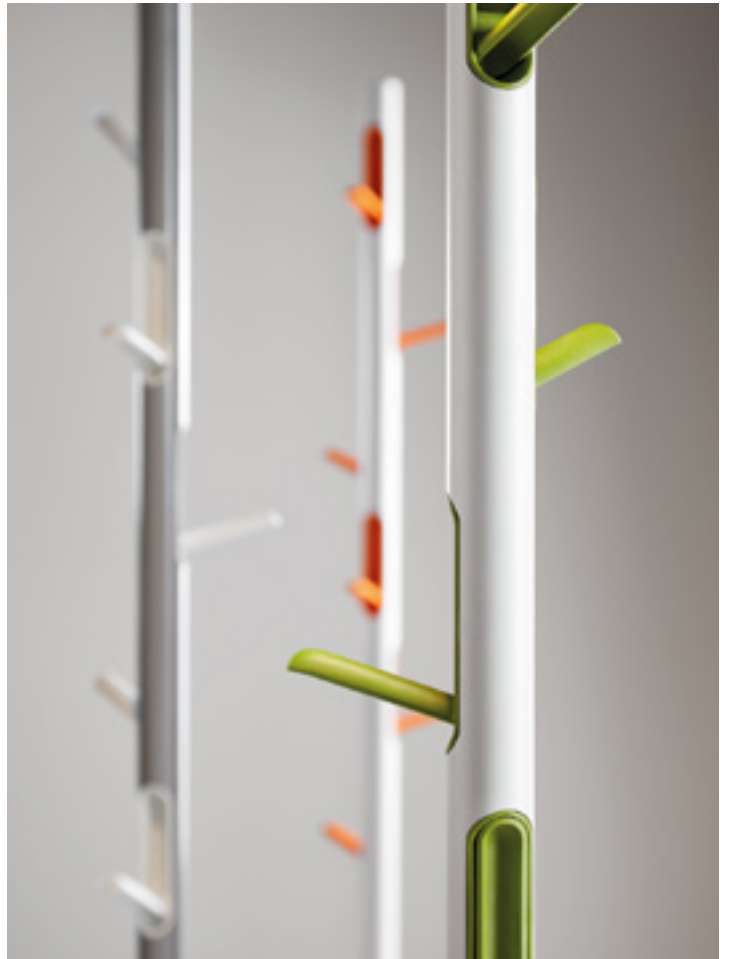

COAT STAND

Napoli

COMFORT

by Eduard Juanola

It's almost a flying coat stand. With its six hangers in the form of two propellers, made of injected plastic on a metal base, it will give a modern and innovative look to any environment, whether at the office or at home. Also available with a matching umbrella stand.

Casi el perchero volador. Con sus seis perchas en forma de dos hélices, fabricadas en plástico inyectado sobre un pie metálico, le dará un aire moderno e innovador a tu espacio, ya sea en espacios de trabajo o confort. También dispone de un paraguero a juego.

Donner des ailes à votre porte-manteau. Avec ses six patères en forme d'hélices, en plastique injecté sur un pied métallique, il donnera un look moderne et innovant à votre espace, que ce soit dans les espaces de travail ou de confort. Il existe également un porte-parapluie assorti.







More about Napoli

DESIGNER
Eduard Juanola

YEAR
2019

LINE SKETCH

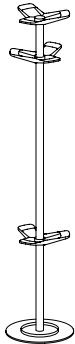

SCALE 1:40 (cm)

PRODUCT



REFERENCE

NAP 01

SIZE
Ø36 x 180 cm
Ø14,2 x 70,9 in.

NAP 10

Ø36 x 180 cm
Ø14,2 x 70,9 in.

NAP P

Ø36 x 50 cm
Ø14,2 x 19,7 in.



DETAILS



BOTTOM HANGER DETAIL – NAP 02 9003

COMFORT

COLOURS

-  RAL 9003 + 9003
-  RAL 9003 + 2004
-  RAL 9003 + 7016

CUSTOMISE OPTIONS

-  COLOUR

HUMAN PERCEPTION

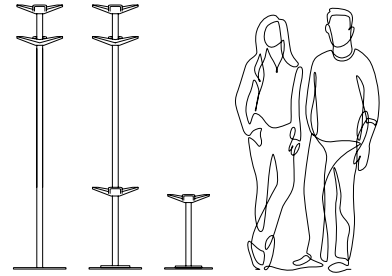

HOOK BETWEEN HANGERS – NAP 02 2004



TOP AND BOTTOM HANGER SYSTEM – NAP 02 + 7016

Bamboo

COMFORT

by Stone Designs

Inspired by the stem of the bamboo cane, this panel will help absorb sound. It can be hung vertically and horizontally, choose the colour and play with these shapes to create your very own design, the sound absorbing acoustic panel will do the rest.

Inspirado en el tallo de la caña de bamboo, este panel ayudará a absorber el sonido. Puedes combinar la colocación en vertical u horizontal sobre la pared, elige el color y juega con su forma de manera creativa, el panel acústico fonoabsorbente hará el resto.

Inspiré de la canne de bambou, ce panneau aidera à absorber le son. Vous pouvez combiner le placement vertical ou horizontal sur le mur, choisir la couleur et jouer avec votre forme de façon créative, le panneau acoustique insonorisant fera le reste.







More about Bamboo

DESIGNER
Stone Designs

YEAR
2015

LINE SKETCH



SCALE 1:20 (cm)

PRODUCT



REFERENCE
BAM 01

SIZE
15 x 10 x 60 cm
5,9 x 3,9 x 23,6 in.

DETAILS



MAGNETIC FIXING SYSTEM — BAM 01



BAMBOO INSTALLATION

COMFORT

COLOURS

- AM · YELLOW
- NJ · ORANGE
- MR · BROWN
- AZ · BLUE
- VDC · LIGHT GREEN
- VD · GREEN
- FO · FOREST
- GR · GREY
- AN · ANTHRACITE

CUSTOMISE OPTIONS



HUMAN PERCEPTION

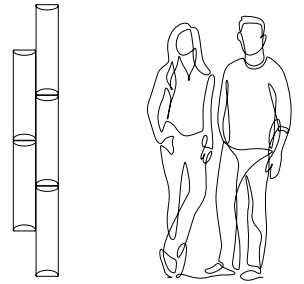

COLOUR RANGE

Note-it

COMFORT

by Jordi Blasi + Nahtrang

Imagine filling the wall with the legendary removable notes, but instead of for writing they absorb sound. This is what our sound-absorbing panels do in a very functional and modular way, attached to the wall using velcro. Just choose the colour, size and quantity, unleash your creativity

Imagina llenar la pared con las míticas notas removibles, pero que en vez de para escribir sirvieran para absorber el sonido. Esto es lo que hacen nuestros paneles fonoabsorbentes de manera muy funcional y modular, con sujeción a la pared mediante velcro. Solo elige el color, el tamaño y la cantidad, luego da rienda suelta a tu creatividad para colocarlas.

Imaginez remplir un mur avec les légendaires notes amovibles, mais au lieu d'écrire, pour absorber le son. C'est ce que font nos panneaux insonorisant de manière très fonctionnelle et modulable, fixés au mur à l'aide de velcro. Il suffit de choisir la couleur, la taille et la quantité, puis de laisser libre cours à votre créativité pour les placer.







More about Note-it

DESIGNER
Jordi Blasi + Nahtrang

YEAR
2018

LINE SKETCH

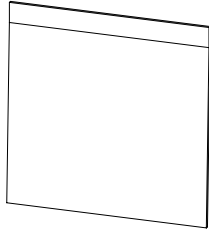

SCALE 1:20 (cm)

PRODUCT

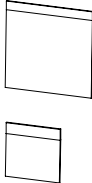

REFERENCE

NOT 60

SIZE

59 x 59 x 0,9 cm
23,2 x 23,2 x 0,35 in.

NOT 30

29 x 29 x 0,9 cm
11,4 x 11,4 x 0,35 in.

DETAILS



COLOURS





MOUNTED PANEL DETAIL

COMFORT

COLOURS

-  GR · GREY
-  AN · ANTHRACITE
-  NG · BLACK
-  AM · YELLOW
-  NJ · ORANGE
-  AZ · BLUE
-  VD · GREEN

CUSTOMISE OPTIONS

-  COLOUR
-  HEIGHT & WIDTH

HUMAN PERCEPTION

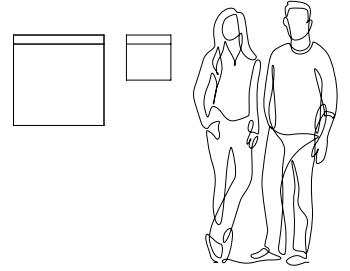

DETAILED SECTION TO FACILITATE INSTALLATION



VELCRO FASTENING SYSTEM ON THE WALL

Vevey Acoustic

bybaumgartner

COMFORT

It is ideal for improving acoustics and sound reverberation in public places or work spaces. Being a modular panel allows you to be very creative when hanging it. Absorb the sound with this asymmetric geometric piece.

Es ideal para mejorar la acústica y la reverberación del sonido en lugares públicos o espacios de trabajo. Al ser un panel modular te permite ser muy creativo a la hora de colocarlo. Absorbe el sonido con esta pieza geométrica asimétrica.

Il est idéal pour améliorer l'acoustique et la réverbération du son dans les lieux publics ou les espaces de travail. Un panneau modulaire qui vous permettra d'être très créatif lors de sa mise en place. Absorbez le son avec cette pièce géométrique asymétrique.







More about Vevey Acoustic

DESIGNER
bybaumgartner

YEAR
2019

LINE SKETCH

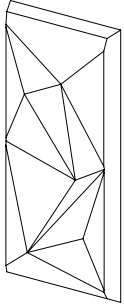

SCALE 1:20 (cm)

PRODUCT

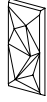

REFERENCE
VVY 10

SIZE
44 x 84 x 7 cm
17,3 x 33,1 x 2,8 in

DETAILS









INSTALLATION DETAIL



MAGNETIC FIXING SYSTEM

COMFORT

COLOURS

-  AM · YELLOW
-  NJ · ORANGE
-  MR · BROWN
-  AZ · BLUE
-  VDC · LIGHT GREEN
-  VD · GREEN
-  FO · FOREST
-  GR · GREY
-  AN · ANTHRACITE

CUSTOMISE OPTIONS

-  COLOUR

HUMAN PERCEPTION

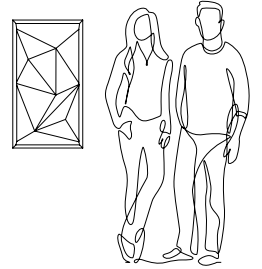

COLOUR RANGE

Kyoto

COMFORT

by Joan Gaspar

An indoor planter that will enhance any interior with a self-watering system in case you forget to water the plants. Available in two sizes and five colours.

Una jardinera de interior que le dará frescura a tu espacio. Con un sistema de autorriego por si eres de los que se te olvida regar las plantas. Disponible en dos alturas y cinco colores.

Une jardinière d'intérieur qui donnera de la fraîcheur à votre espace. Avec un système d'auto-arrosage pour si vous êtes de ceux qui oublie d'arroser les plantes. Disponible en deux hauteurs et cinq couleurs.





3

301 - 310



311 - 320



More about Kyoto

DESIGNER
Joan Gaspar

YEAR
2005

LINE SKETCH

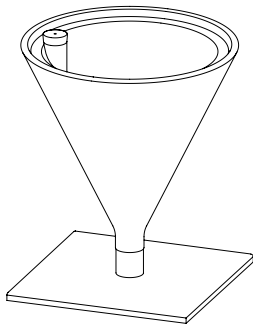

SCALE 1:10 (cm)

PRODUCT

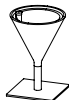

REFERENCE

KYT 01

SIZE
Ø39,6 x 44 cm
Ø15,6 x 17,3 in.

KYT 02

SIZE
Ø39,6 x 57 cm
Ø15,6 x 22,4 in.

DETAILS



BASES AND SIZE DETAIL – KYT 02 9011 + KYT01 9011

COMFORT

COLOURS

- BL · RAL 9003
- MO · RAL 1012
- TC · RAL 2001
- AN · RAL 7016
- NG · RAL 9011

HUMAN PERCEPTION

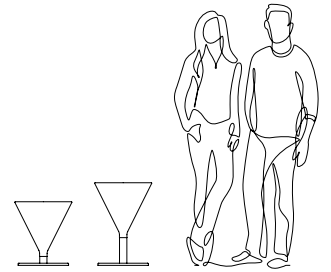

KYOTO SET – KYT 01 9003



SELF WATERING SYSTEM

Sapporo

COMFORT

by Toni Pallejà

It's geometric shape evokes the world of origami. Simple and contemporary this side table is ideal for living rooms and waiting areas. Available in seven attractive colours and made from three millimetre steel.

Su forma geométrica evoca al mundo de la papiroflexia. Simple y contemporánea esta mesita auxiliar es idónea para salones y áreas de espera. Disponible en siete atractivos colores y fabricada en acero de tres milímetros.

Sa forme géométrique évoque le monde de l'origami. Simple et contemporaine, cette table d'appoint est idéale pour les salons et les zones d'attente. Disponible en sept couleurs attrayantes et fabriquée en acier de trois millimètres d'épaisseur.







More about Sapporo

DESIGNER
Toni Pallejà

YEAR
2007

LINE SKETCH

PRODUCT



REFERENCE
SPR 01

SIZE
58 x 43,3 x 28 cm
22,8 x 17 x 11 in.

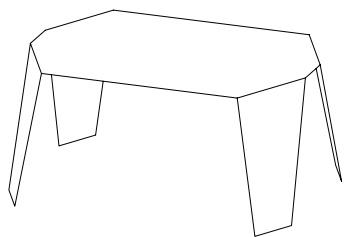

SCALE 1:20 (cm)

DETAILS



COLOUR RANGE

COMFORT

COLOURS

- RAL 9003
- RAL 1023
- RAL 2004
- RAL 3027
- RAL 5012
- RAL 6018
- RAL 7016

CUSTOMISE OPTIONS



HUMAN PERCEPTION

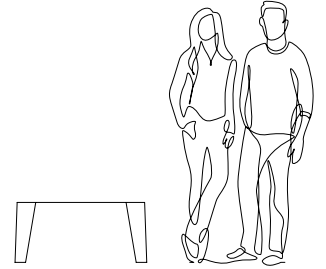

IT'S ALIVE!



DETAIL VIEW

Adelaida

COMFORT

by Lluís Porqueras

A classic iconic modular shelving system with a unique and distinctive design which will turn any wall into a perfect canvas to create a shelf adapted to all your needs. Lateral and intermediate steel straps that secure the shelves made from lacquered wood. It is totally modular and adaptable to any interior.

Un icono clásico de las estanterías con un diseño único y distintivo, convertirá cualquier pared en un lienzo perfecto para crear una estantería adaptada a tus necesidades. Flejes de acero laterales e intermedios que sujetarán los estantes de madera lacada. Es totalmente modular y adaptable a cualquier espacio.

Une icône classique des étagères avec un design unique et distinctif, il transformera chaque mur en une toile parfaite pour créer une étagère adaptée à vos besoins. Profils latéraux et intermédiaires en acier qui supporteront les étagères en bois laqué. Il est totalement modulaire et adaptable à tout espace.







More about Adelaida

DESIGNER
Lluís Porqueras

YEAR
2001

LINE SKETCH

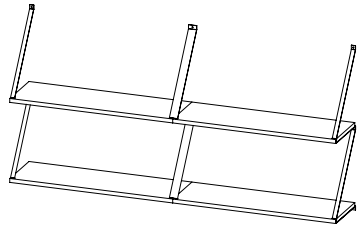

SCALE 1:40 (cm)

PRODUCT



REFERENCE

ADL 01

SIZE

80 x 25 x 1,9 cm
31,5 x 9,8 x 0,7 in.

Shelf

ADL 11

2 x 25 x 41,2 cm
0,8 x 9,8 x 16,2 in.

Side bracket

ADL 12

4 x 25 x 41,2 cm
1,6 x 9,8 x 16,2 in.

Central bracket

DETAILS



BRACKET SIDE VIEW

COMFORT

COLOURS

○ RAL 9003

● RAL 9005

CUSTOMISE OPTIONS

● COLOUR

HUMAN PERCEPTION

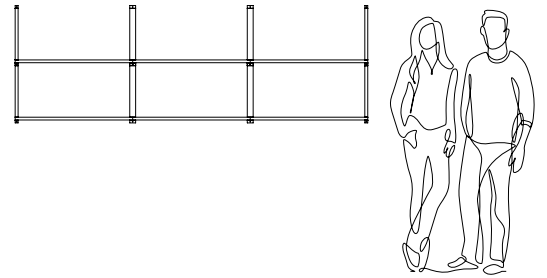

SHELF DETAIL



CENTRAL BRACKET CLOSE UP

Albury

COMFORT

by Drop Innovation

A honeycomb shaped modular shelving system with wall and floor support, its modular metal structure allows you to make unequal and creative combinations. Breaking the space sympathetically creating a library to your liking. It also has a more minimalist design to use horizontally and an optional magnetic mini-shelf to horizontally place objects.

Estantería en forma de panal de abeja con apoyo en el suelo, su estructura metálica modular permite hacer combinaciones desiguales y creativas. Rompe de manera simpática el espacio y ordena la biblioteca a tu gusto. También tiene un modelo para usar en horizontal más minimalista y un mini-estante magnético opcional para alinear horizontalmente algún objeto.

Rayonnage en forme de nid d'abeille appuyé sur le sol, sa structure métallique modulaire permet de faire des combinaisons asymétriques et créatives. Brisez l'espace avec sympathie et organisez la bibliothèque à votre guise. Il existe également un modèle plus minimaliste à utiliser horizontalement et une mini-étagère magnétique en option pour aligner horizontalement un objet.







More about Albury

DESIGNER
Drop Innovation

YEAR
2016

LINE SKETCH

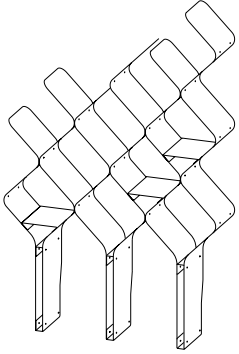

SCALE 1:20 (cm)

PRODUCT

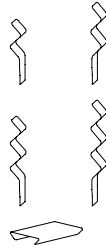

REFERENCE

ALB 03

SIZE

21 x 28 x 112 cm
8,3 x 11 x 44,1 in.

ALB 04

21 x 28 x 147,4 cm
8,3 x 11 x 58 in.

ALB 05

21 x 28 x 172,8 cm
8,3 x 11 x 68 in.

ALB 06

21 x 28 x 198,2 cm
8,3 x 11 x 78 in.

ALB 10

21 x 28 x 4 cm
8,3 x 11 x 1,6 in.

Magnetic shelf

ALB 20

152 x 24 x 21 cm
59,8 x 9,4 x 8,3 in.

ALB 11

21 x 24 x 4 cm
8,3 x 9,4 x 1,6 in.

Magnetic shelf

DETAILS

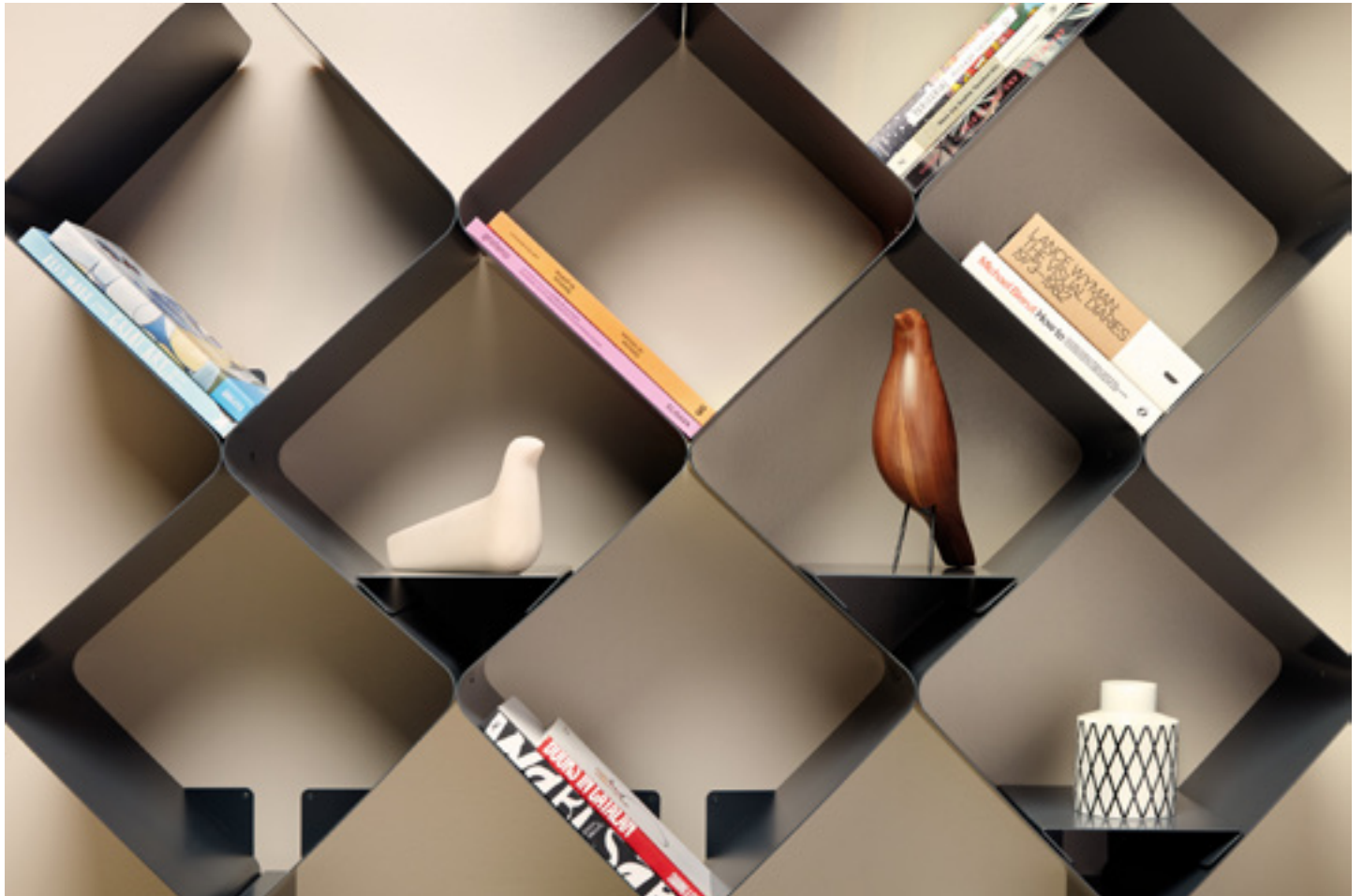

ALBURY SET WITH HORIZONTAL MAGNETIC SHELF

COMFORT

COLOURS

○ RAL 9003

● RAL 7016

CUSTOMISE OPTIONS

● COLOUR

HUMAN PERCEPTION

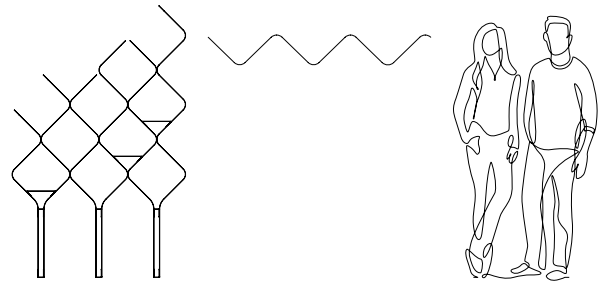

HORIZONTAL ALBURY WITH MAGNETIC SHELF — ALB 20 9003

Nagoya

COMFORT

by Joan Gaspar

Arriving at the lectern to give a speech, you position yourself and realise this is not just any lectern, it's a unique design, solid and comfortable. Not only enhancing the stage with its upholstered structure and its sinuous shape this beautiful lectern stands out from the crowd and gives confidence to the orator.

Llegas al atril para dar un discurso, te posicionas en él y ahí te das cuenta que no es un atril cualquiera, es una pieza única, sólida y confortable. No solo realza tu espacio con su estructura tapizada y su sinuosa forma, sino que además ofrece seguridad al orador.

Vous arrivez devant le pupitre pour donner un discours, vous vous y positionnez et vous vous rendez compte que ce n'est pas un pupitre, mais une pièce unique, solide et confortable. Non seulement il améliore votre espace avec sa structure rembourrée et sa forme sinueuse, mais il proportionne également de la sécurité à l'orateur.







More about Nagoya

DESIGNER
Joan Gaspar

YEAR
2010

LINE SKETCH

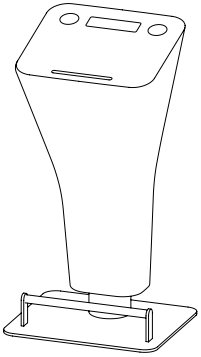

SCALE 1:20 (cm)

PRODUCT



REFERENCE

NAG 01

SIZE

60 x 50 x 114 cm
23,6 x 19,7 x 44,9 in.

NAG 02

60 x 50 x 114 cm
23,6 x 19,7 x 44,9 in.

NAG 15

NAG 20

NAG 30

Lamp
Microphone
A4 Sign

DETAILS



LED LIGHT AND MICROPHONE DETAIL

COMFORT

COLOURS

○ WHITE

● VIOLET

● ANTHRACITE

CUSTOMISE OPTIONS

● COLOUR

HUMAN PERCEPTION

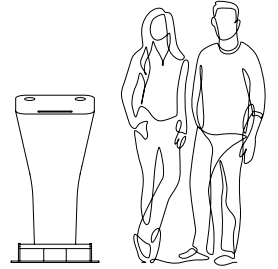

SPACE FOR PLUGS & CONNECTIONS
FOOTREST DETAIL



NAGOYA SET

Osaka

COMFORT

by Mar Vaíllo

It will preside over the meeting room with elegance and comfort, while allowing you to move it from one side to the other thanks to its minimalist, lightweight structure and wheels. The surface of white flattened wood allows the use of dry erase pens and also has a fastening system for paper pads.

Presidirá la sala de reuniones con una elegancia y confortabilidad, a la vez que te permitirá desplazarla de un lado a otro gracias a su estructura minimalista, ligera y con ruedas. La superficie de madera aplacada en blanco permite el borrado en seco, también cuenta con un sistema de sujeción para blocs de papel.

Il présidera la salle de réunion avec élégance et confort, tout en vous permettant de le déplacer d'un côté à l'autre grâce à sa structure et ses roues minimalistes et légères. La surface en bois laqué blanc permet un effacement à sec, elle dispose également d'un système de fixation pour les blocs de papier.

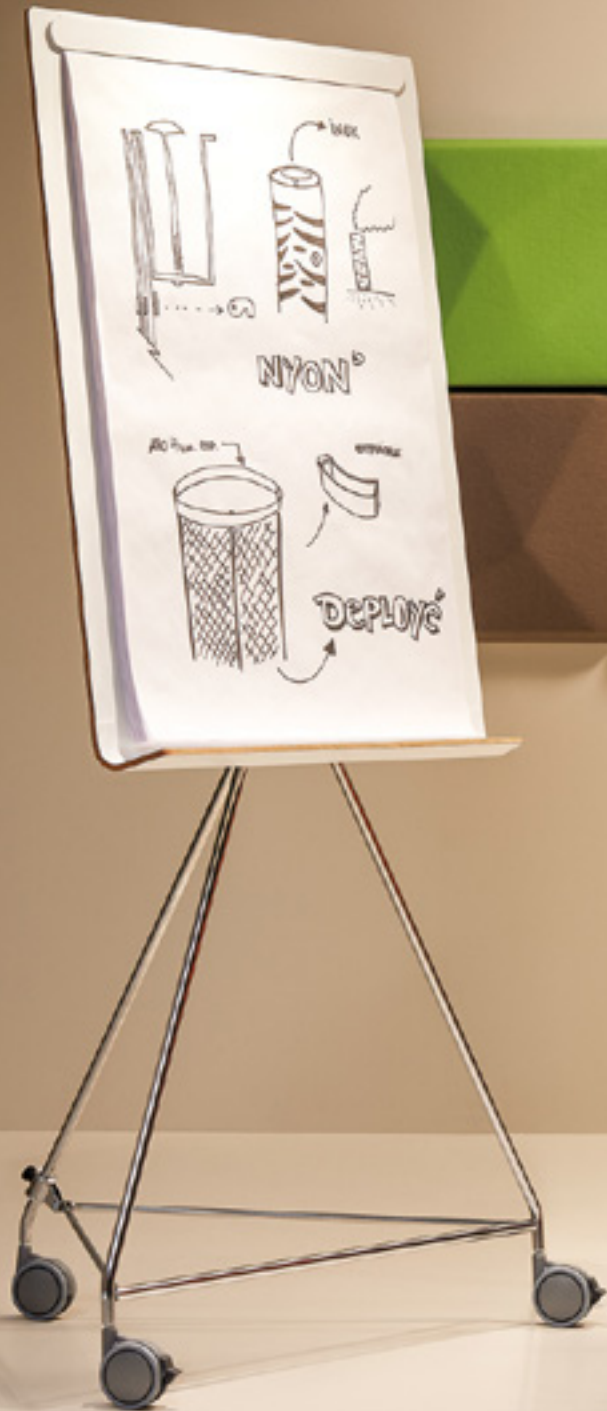

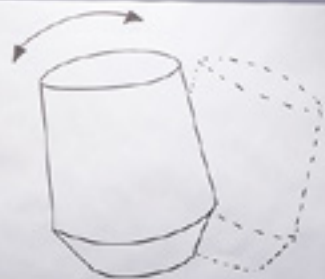

Biel



PADOVA



More about Osaka

DESIGNER
Mar Vaillo

YEAR
2010

LINE SKETCH

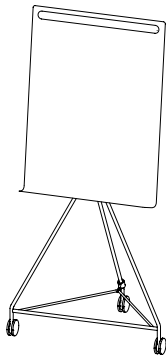

SCALE 10:200 (MM)

PRODUCT



REFERENCE
OSK 01

SIZE
81 x 60 x 180 cm
31,9 x 23,6 x 70,9 in.

DETAILS



PAPER CLIP HOLDING SYSTEM



CURVED DETAIL THAT SERVES AS SUPPORT FOR MARKERS AND ERASER

COMFORT

COLOURS

WOOD + WHITEBOARD

HUMAN PERCEPTION

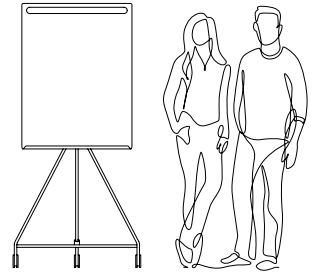

ADJUSTABLE IN HEIGHT
FLAT FOLDING SYSTEM



DRY WRITING BOARD



Menfis

COMFORT

by Mario Ruiz

This range of minimalist signage makes the message relevant; it's almost invisible form is perfect for all types of public or private buildings. For wall, desktop, free standing, hanging and projected it's a modular system with custom size, allows you to adapt to all your needs.

Esta gama de señalética minimalista hace relevante el mensaje, su forma casi invisible es perfecta para todo tipo de edificios públicos o privados. Para pared, sobremesa, de pie, colgante y proyectado y un sistema modular con tamaño personalizado, le permite adaptarse a todas las necesidades.

Cette gamme de signalétique minimaliste rend le message pertinent, sa forme presque invisible est parfaite pour tous les types de bâtiments publics ou privés. Sur le mur, le bureau, debout, suspendu et projeté, il s'agit d'un système modulaire à la taille personnalisée, il permet de s'adapter à tous les besoins.

FLOOR 2
B1

Depo, K2
Keriting

Waiting area



Information

FLOOR 2
B1

InfoSpace, N.J.
New York



Waiting area



South Building

Starr George Medical Center

Floor 3 Psychiatry

Floor 2 Neurology

Floor 1 Dermatology

Floor 0 Entry



MEETING ROOM

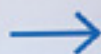

More about Memphis

DESIGNER
Mario Ruiz

YEAR
2010

LINE SKETCH

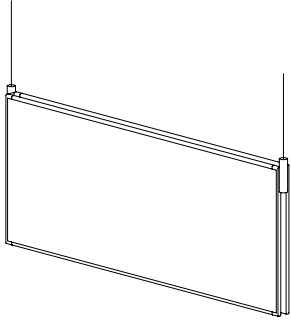

SCALE 1:10 (cm)

HUMAN PERCEPTION

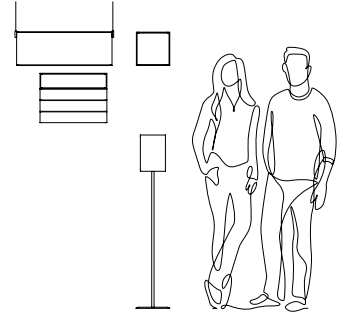

DETAILS



HANGING SUPPORT — MEN 21
DESKTOP SUPPORT — MEN 31

COMPOSITION WITH WALL SUPPORT — MEN 01 + MEN 03
STANDING SUPPORT DETAIL — MEN 41





COMFORT

COLOURS

 RAL 9003

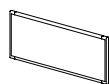
CUSTOMISE OPTIONS

 COLOUR

PRODUCT	REFERENCE	SIZE											
WALL MOUNT 		x x	5 2	7 2,7	10,5 4,1	21 8,3	29,7 11,7	32 12,6	48 18,9	64 25,2	72 28,3	96 37,8	cm in.
	MEN 01		21 8,3			•	•	•	•	•	•	•	
	MEN 02		10,5 4,1		•	•	•	•	•	•	•	•	
	MEN 03		7 2,7		•	•	•	•	•	•	•	•	
	MEN 04		5,25 2,1		•	•	•	•	•	•	•	•	
PROJECTED 		x x	5 2	7 2,7	10,5 4,1	21 8,3	29,7 11,7	32 12,6	48 18,9	64 25,2	72 28,3	96 37,8	cm in.
	MEN 11		21 8,3			•	•						
	MEN 12		10,5 4,1			•	•						
HANG 	MEN 21	x x	5 2	7 2,7	10,5 4,1	21 8,3	29,7 11,7	32 12,6	48 18,9	64 25,2	72 28,3	96 37,8	cm in.
			21 8,3						•	•	•	•	
DESK 		x x	5 2	7 2,7	10,5 4,1	21 8,3	29,7 11,7	32 12,6	48 18,9	64 25,2	72 28,3	96 37,8	cm in.
	MEN 31		21 8,3			•	•						
	MEN 32		10,5 4,1		•	•							
	MEN 33		7 2,7		•	•							
	MEN 34		5,25 2,1		•	•							
STAND 	MEN 41	x x	5 2	7 2,7	10,5 4,1	21 8,3	29,7 11,7	32 12,6	48 18,9	64 25,2	72 28,3	96 37,8	cm in.
			21 8,3			•	•						

Customise
products
in your
own style





Pictograms

Customise our bins by changing the pictograms, adapt them to your style or corporate identity, let them advertise your brand.

Personaliza nuestras papeleras cambiando los pictogramas según necesites para adaptarlos a tu estilo o identidad corporativa, así hablarán de la misma manera que tu marca.

Personnalisez nos corbeilles en modifiant les pictogrammes, vous pourrez les adapter à votre style ou à votre identité d'entreprise, ils parleront ainsi de la même manière que votre marque.



Colours

Develop your own style by personalizing the colours of our products, making them unique and transforming the design and essence of your space.

Consigue un estilo propio personalizando el color de nuestros productos, convirtiéndolos en únicos y transforma el ambiente y la esencia de tu espacio.

Créez votre propre style en personnalisant la couleur de nos produits, en les rendant uniques et en transformant l'environnement et l'essence de votre espace.

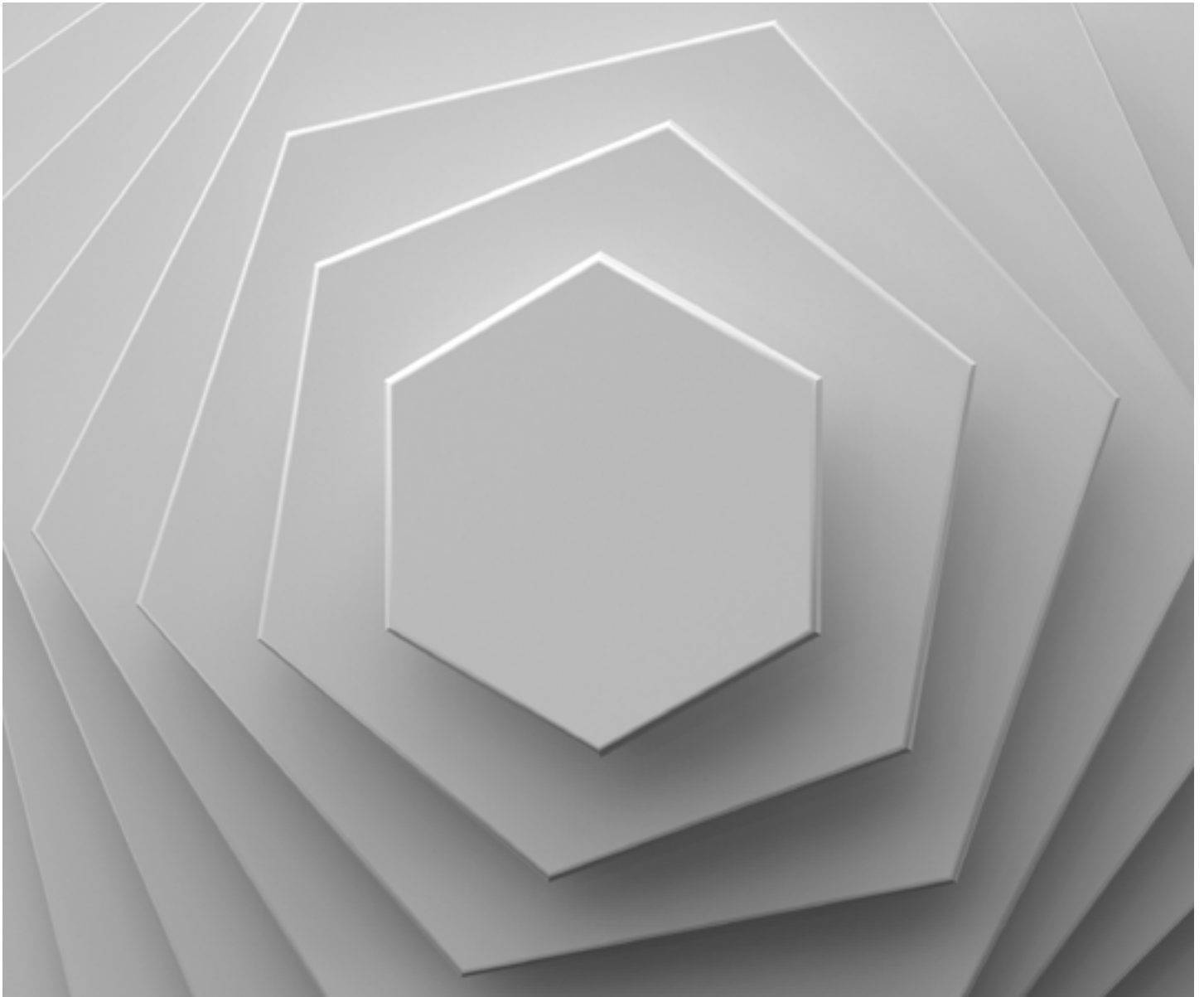

Customise

Reduce or enlarge the size of our bins, modify our products, adjusting them to your design and requirements.

Encoge o agranda el tamaño de nuestras papeleras, modifica nuestros productos comfort, ajustándolos a tu espacio y necesidades.

Réduisez ou agrandissez la taille de nos corbeilles, modifiez nos produits en les adaptant à votre espace et à vos besoins.



From the beginning

If you can't find what you are looking for in our collection, we can always design and manufacture especially for you.

Si no encuentras lo que buscas en nuestra colección, siempre podemos diseñar y fabricar un accesorio especialmente para ti.

Si vous ne trouvez pas ce que vous recherchez dans notre collection, nous pouvons toujours concevoir et fabriquer un accessoire spécialement pour vous.

Designers

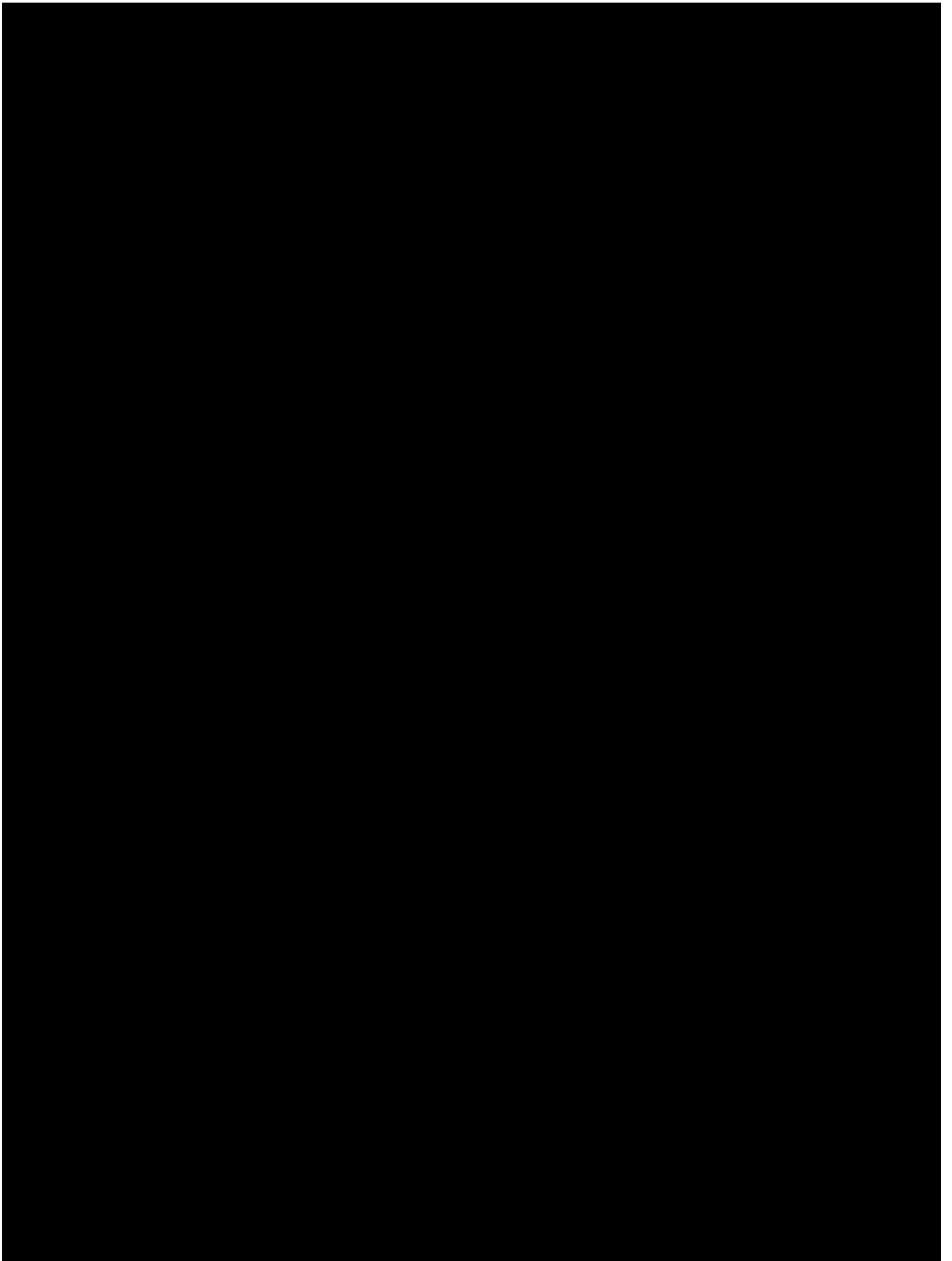

byBaumgartner

Vevey³⁴
Vevey Acoustic¹⁷⁰



Juan Carlos Baumgarten is a Mexican architect and designer grown and formed in Mexico City, San Francisco, Chicago and Milan. He is currently at the head of the international architectural firm Space, with offices in Mexico City, Monterrey and Guadalajara. He has received more than 80 international awards and has been in charge of the design of more than 3 million m² in 12 countries.

Named by Forbes as one of the “most creative Mexicans in the world” is considered an emblematic architect and pioneer in corporate design in Mexico, recognized as one of the leading futurists in the country.

He is currently immersed in research related to neuroarchitecture and his dream is to design spaces that promote happiness, developing architecture to heal the soul.

Juan Carlos Baumgartner es un arquitecto y diseñador mexicano, formado en Ciudad de México, San Francisco, Chicago y Milán. Actualmente al frente de la firma internacional de arquitectura Space, con oficinas en CdMx, Monterrey y Guadalajara. Ha recibido más de 80 premios internacionales y ha estado al frente del diseño de más de 3 millones de m² en 12 países.

Nombrado por la revista Forbes como uno de los “Mexicanos más creativos del mundo” es considerado un arquitecto emblemático y pionero en el diseño corporativo en México, reconocido como uno de los principales futuristas del país.

Actualmente está inmerso en investigaciones relacionadas con NeuroArquitectura y su sueño es diseñar espacios que promuevan la felicidad, desarrollando arquitectura para sanar el alma.

CrousCalogero

Lugano⁷⁸



Resulting from a collaboration between Francesc Crous and Alessandro Calogero. Professionals of product design that combine their abilities to develop a work that aims to reach the essence of things eliminating that superfluous and always keeping the human being in the centre.

This is how they describe their methodology: “We want our objects, the matter and detail of each product, to transmit the desire to be touched and observed closely.” Functionality is a basic requirement that we take for granted and about which we try to suggest a story, made of memories and sensations, that generates the impalpable link between object and person.

The work of Francesc Crous and Alessandro Calogero has gained international recognition by winning prestigious awards such as the Silver Delta 2012 among others.

CrousCalogero, firma de diseño, es fruto de la colaboración entre Francesc Crous y Alessandro Calogero. Profesionales del diseño de producto que aúnan sus capacidades para desarrollar un trabajo que pretende llegar a la esencia de las cosas eliminando aquello superfluo y manteniendo siempre al ser humano en el centro.

Así es como describen su metodología: “Queremos que nuestros objetos, la materia y detalle de cada producto, transmitan el deseo de ser tocados y observados de cerca. La funcionalidad es un requisito de base que damos por sentado y sobre el cual tratamos de sugerir una historia, hecha de memorias y sensaciones, que genere el vínculo impalpable entre objeto y persona.”

El trabajo de Francesc Crous y Alessandro Calogero ha obtenido reconocimiento internacional ganando prestigiosos premios como el Delta de Plata 2012 entre otros.

Drop Innovation

Albury¹⁹⁴



Hello, we are drop. We make tangible innovation through design thinking & design doing.

We are a company of Experience Innovation, applied to the creation of new products and services, focused on the user experience and business models. We adapt our services and collaboration models to the needs of the client. With a holistic vision that allows us to generate high added value solutions acting in the three key areas of innovation.

Constituted by a multidisciplinary team, with more than 15 years of accumulated experience in different sectors of design and innovation. We go from strategy to design and implementation. We believe that the “what” is the “how”: it is about how the products / services are brought to market. We collaborate with multinationals, SMEs, start-ups, research centres and universities to develop exceptional and innovative solutions with high impact in the market.

Hola, somos drop. Hacemos la innovación tangible a través del design thinking & design doing.

Somos una compañía de Experience Innovation, aplicada a la creación de nuevos productos y servicios, centrados en la experiencia de usuario y los modelos de negocio. Adaptamos nuestros servicios y modelos de colaboración a las necesidades del cliente. Con una visión holística que nos permite generar soluciones de alto valor añadido actuando en las tres áreas clave de la innovación.

Constituida por un equipo multidisciplinar, con más de 15 años de experiencia acumulada en diferentes sectores del diseño y la innovación. Vamos desde la estrategia al diseño y la implementación. Creemos que el “qué” es el “cómo”: se trata de cómo se llevan los productos/servicios al mercado. Colaboramos con multinacionales, PyMES, start-ups, centros de investigación y universidades para desarrollar soluciones excepcionales e innovadoras con alto impacto en el mercado.

Eduard Juanola

Bologna ¹³⁴
Torino ¹⁴⁶
Napoli ¹⁵²



Industrial Designer trained at the EDI IN Sabadell Catalonia and now resident in Barcelona.

Today he is the design director at Crea Product Design and is also avisting profesor at the Elisava School of Design.

His Designs are the result of finding exactly the right solution to satisfy the most demanding design briefs, investigating until the right solution is found and the client is satisfied on every occasion.

Diseñador industrial formado en la escuela EDI de Sabadell e instalado en Barcelona.

Dirige el estudio Crea Product Design y es profesor en la escuela Elisava.

Su diseño es el resultado de la combinación adecuada de recursos por satisfacer las necesidades del usuario y la empresa, al mismo tiempo ofrece un carácter emotivo a este encuentro.

Minucioso con los detalles y la investigación de la solución óptima para cada ocasión.

Estudi Ribaudí

Zell ⁵⁸



Estudi Ribaudí works with tools, makes them grow and transforms them into objects.

Led by Jordi Ribaudí, his creative proposals mix creativity, mastery and technology creating objects with identity. His studio works with companies from different sectors offering fresh proposals capable of connecting with people. They also collaborate with well-known fashion brands, creating new retail concepts and shopping experiences.

Beyond the product design, the studio is promoting the REC.O Experimental Stores project since 2009. The objective is to recover the industrial architecture of the Rec d'Igualada neighborhood, with the installation of ephemeral "pop-up" stores.

Last 2016, Ribaudí launched its own furniture producer, Toru. To work and experiment with the leather that is manufactured in Igualada since centuries ago, is its original motivation.

Estudi Ribaudí trabaja con las herramientas, las hace crecer y las transforma en objetos.

Liderado por Jordi Ribaudí, sus propuestas creativas mezclan creatividad, maestría y tecnología creando objetos con identidad. Su estudio trabaja con empresas de diferentes sectores ofreciendo propuestas frescas capaces de conectar con las personas. También colaboran con conocidas marcas de moda, creando nuevos conceptos de retail y experiencia de compra.

Más allá del diseño de producto, el estudio impulsa des de 2009 el proyecto REC.O Experimental Stores. El objetivo es recuperar la arquitectura industrial del barrio Rec de Igualada, con la instalación de tiendas de "pop-up" efímeras.

El pasado 2016, Ribaudí lanzó su propia productora de mobiliario, Toru. Trabajar i experimentar con el cuero que se fabrica en Igualada des de hace siglos, es su motivación original.

Grup Idea

Baden SB_system ⁷⁶

We are an international company specializing in design, implementation and construction of spaces that reflect the value of the brands.

We design spaces that integrate, through innovation and imagination, all the necessary disciplines to convey the value of brands as best as possible. We use Design Thinking and Open Innovation to fuel innovation and offer a surprising final product.

Grup Idea es una empresa internacional especializada en imaginar, diseñar y construir espacios que reflejan e integran el valor de las marcas.

Imaginamos los espacios, el mobiliario y los complementos a partir del modelo de negocio y el usuario. Nuestro método de trabajo está basado en el "design thinking" y la innovación abierta. Garantizamos un resultado final siempre sorprendente y rentable.



Joan Gaspar

Nagoya ²⁰⁰
Kyoto ¹⁷⁶
Zurich ⁴⁶



I began to learn the craft of designing under the guidance of Lluís Porqueras at the end of the 80s.

Today, I am a seasoned professional, but one who often thinks that his designs still retain the essence of those early years, given that I am still more interested in explaining how I have done things and showing how I have solved problems, rather than in the end result per se. That is not to say that the end result does not interest me, obviously it is very important, but, since the solution, about which everyone has their own opinion, is apparent, I feel that no one, other than its creator, can explain its hidden secrets knowledgeably and with passion.

Aprendí el oficio de diseñador industrial de la mano de Lluís Porqueras a finales de la década de los 80.

Hoy soy un profesional maduro, que normalmente piensa que sus trabajos aun mantienen el espíritu de aquellos primeros años, teniendo en cuenta que me sigue interesando más hablar de como he realizado las cosas y como las he resuelto que el resultado final; y no porque el resultado final no me interese, en realidad es realmente importante, sino porque el resultado final es obvio y hay que dejar que se juzgue, y los detalles invisibles solamente el autor los puede explicar con conocimiento y pasión.

Jordi Blasi

Capri ¹²²
Note-it ¹⁶⁴



Industrial Designer graduated from Eina, Design and Arts College, Barcelona, has worked for several design studios in the areas of product, packaging, furniture, and lighting. Experience in design process including product conceptualization, sketching, rendering and product development.

Working as a freelance designer since 2010 collaborates as a Lecturer with ESdesign and IED Barcelona Schools, and as an Editorial Writer with On Diseño and Experimenta magazines.

Diseñador Industrial por Eina, Centro Universitario de Diseño y Arte, ha trabajado para varios estudios en las áreas de producto, packaging, mobiliario e iluminación. Tiene una amplia experiencia en las distintas fases que intervienen en el proceso de diseño, desde la conceptualización hasta el desarrollo de nuevos productos.

Establecido como diseñador autónomo en 2010, compagina su actividad profesional con la docencia, siendo actualmente profesor de las escuelas ESdesign e IED Barcelona, y como redactor en medios de comunicación especializados en diseño, en las revistas On Diseño y Experimenta.

La Mamba Studio

Bergamo ¹¹⁰



In 2008 Raúl Durá, Ommar Uribe and Pedro Rivera founded La Mamba studio, established to offer product design projects and branding to the furniture and lighting industry, as well as art direction and consultancy.

By 2012, having acquired the necessary experience, they decided to create their own product editing company for habitat and contract, Omelette-ed, in order to achieve the development of products based on usability analysis, materiality and sustainability, as well as a visual reduction process.

En 2008 Raúl Durá, Ommar Uribe y Pedro Rivera fundan La Mamba studio ofreciendo servicio a empresas del sector del mueble y la iluminación, desarrollando proyectos de diseño de producto y branding, así como la dirección de arte y asesoramiento de empresas.

En el año 2012, tras su experiencia en el sector, deciden montar su propia editora de productos para el hábitat y colectividades (Omelette-ed), tratando de desarrollar de esta manera productos que se basan en análisis de usabilidad, la materialidad, la sostenibilidad y un proceso de reducción visual.

Lluís Porqueras

Adelaida ¹⁸⁸

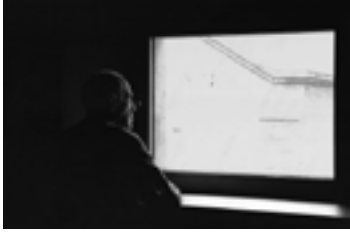

Barcelona, 1930-2018. Lluís Porqueras was one of Catalonia's most influential people in design. His career began with several architectural courses renovating farmhouses, and he later joined a number of contemporary designers to create their own studios: Stoa and Vapor.

Living in a post-war Spain and opposing the High-tech architecture trend, he started shaping the future of design. He left behind his entrepreneur-designer stage and focused on working as a product designer for companies of the sector, specializing in lightning design.

Lluís imagined some of the most iconic designs of Catalonia, many of which continue in constant re-edition and production to this day.

Barcelona, 1930-2018. Una de las figuras más importantes del diseño en Cataluña. Lluís Porqueras se inició con unos cursos de arquitectura rehabilitando varias masías y se juntó posteriormente, con varios diseñadores coetáneos para crear sus propias empresas: Stoa y Vapor.

En un contexto de post-guerra y a contracorriente de la tendencia del High-tech, comenzó a dar a conocer la palabra diseño tal y como la conocemos hoy en día. Una vez dejó de lado su etapa de empresario-diseñador, se centró en la tarea de diseñador trabajando para empresas del sector, especializándose en el diseño productos de iluminación.

Desde sus inicios, ha ido dejando objetos emblemáticos para el diseño catalán, muchos de los cuales siguen en constante reedición y producción hoy en día.

Mar Vaíllo

Osaka ²⁰⁶



Born in Barcelona with an education in fine arts and industrial design over the years designing and developing products in many instances for the technical sector. He works in the studios of Alberto Liévore and above all Ramón Benedito.

She has been teaching at the Elisava School in Barcelona and the Esdi School in Sabadell. In 2012 she founded her own company together with Artur Llorens. The showcases made for the store of the Guggenheim Museum Bilbao and the signage of the Mémora Group Tanatoria stand out as projects.

Interested in everyday design, affordable and that which brings us happiness in our daily lives; he admires the breakthrough designs that make us advance, and he despairs to see the world flooded with so many versions of the same object.

Nacida en Barcelona, con formación en Bellas Artes y en diseño industrial.

Durante años diseña y desarrolla producto, muchas veces de sectores técnicos. Trabaja en los estudios de Alberto Liévore y sobretodo Ramón Benedito.

Ha sido profesora de la Escuela Elisava de Barcelona y la Escuela Esdi de Sabadell. En 2012 funda con Artur Llorens su propia empresa de equipamiento integral de espacios. Destacan como proyectos las vitrinas realizadas para la tienda del Museo Guggenheim Bilbao y la señalización de los Tanatorios del Grupo Mémora.

Interesada en el diseño cotidiano, asequible y aquél que nos aporta felicidad en nuestra vida diaria; admira los diseños rompedores que nos hacen avanzar, y le desespera ver el mundo inundado de tantas versiones de un mismo objeto.

Mario Ruiz

Menfis ²¹²



Born in 1965 in Alicante, Spain, designer Mario Ruiz graduated in Industrial Design from Barcelona's prestigious Elisava Design School. He started his independent professional career in 1995 opening his own studio in Barcelona.

Projects directly related to their products in different fields (domestic and office furniture, lighting, textile design, product design) but also acts as creative director defining their product.

Nacido en Alicante en 1965, el diseñador Mario Ruiz se graduó en Diseño Industrial de la prestigiosa Escuela de Diseño Elisava de Barcelona. Comenzó su carrera profesional independiente en 1995 abriendo su propio estudio en Barcelona.

Proyectos relacionados directamente con sus productos en diferentes campos (mobiliario doméstico y de oficina, iluminación, diseño textil, diseño de producto), pero también actúa como director creativo definiendo su producto.

Nahtrang

Davos ¹⁴
Note-it ¹⁶⁴
Siena ¹²⁸



Nahtrang is a design studio located in Barcelona since 2004. The founders, Daniel Vila and Ester Pujol, both industrial designers by the Escola Massana (Barcelona), are the soul of the office.

Throughout a 14-year career they have worked on a variety of projects such as lighting, bathroom accessories, furniture and urban furniture, always maintaining their philosophy; sincere designs, clean and simple lines creating a very direct language.

This has led them to obtain public recognition through awards such as the ADI of Plata'12, as the NYC X Design 2017, the Restaurant & Bar Product Design Award 2017 or the German Design Award 2018.

Their products have appeared in various publications such as Interior Design, Pin-Up, ON Design, Experimenta, Icon or Wallpaper, Metropolis USA among others.

Nahtrang es un estudio de diseño ubicado en Barcelona desde el 2004. Los fundadores, Daniel Vila y Ester Pujol, ambos diseñadores industriales por la Escola Massana (Barcelona), son el alma de la oficina.

A lo largo de una carrera de 14 años han trabajado en diversidad de proyectos como la iluminación, accesorios de baño, mobiliario y mobiliario urbano manteniendo siempre su filosofía; diseños sinceros, de líneas limpias y sencillas creando un lenguaje muy directo.

Esto les ha llevado a obtener el reconocimiento público mediante premios como el ADI de Plata'12, el NYC X Design 2017, el Restaurant & Bar Product Design Award 2017 o el German Design Award 2018.

Sus productos han aparecido en diversas publicaciones como Interior Design, Pin-Up, ON Diseño, Experimenta, Icon o Wallpaper, Metropolis USA entre otros.

NutCreatives

Treviso ¹⁰⁴



Nutcreatives is a sustainable and an ecoinnovation creatives product design studio. We carry out objects from their origin to the beginning of their production. We help companies and public organizations to achieve their goals, taking into account aesthetics, functionality, recycling, ergonomics, and the social, economic and environmental impact, in order to reach a good design proposal.

Nutcreatives es un estudio de diseño de producto creativo, sostenible y ecoinnovación. Desarrollamos objetos desde su concepción inicial hasta el comienzo de su producción. Ayudamos a empresas y a entidades públicas a alcanzar sus objetivos teniendo en cuenta la estética, la funcionalidad, reciclaje y ergonomía, como el impacto ambiental, social y económico para llegar a una propuesta de buen diseño.

Pascual Salvador

Ginebra ⁸⁴



Is a well known Catalan Industrial Designer who studied at the Massana Institute obtaining degrees in industrial design and interior architecture opening his own studio in Barcelona in 1989 and in Mexico in 2005. Is a member of several prestigious design associations including ADI-FAD, BEDA y ADP. Currently working with several furniture and lighting manufacturers and has won several awards for his designs.

Famoso diseñador industrial catalán, estudia en la Escola Massana de Barcelona y se diploma en Diseño Industrial y Arquitectura Interior. Abre su propio estudio en Barcelona en 1989 y en México en 2005. Forma parte del Consejo de varias prestigiosas asociaciones de diseño, incluyendo ADI-FAD, BEDA y ADP. Trabaja con importantes empresas de mobiliario y luz y ha sido premiado numerosas veces por sus diseños.

Pep Puerto

Basilea ⁵²



Pep puerto understands design from the most technical detail to the estetics, its function and utility.

Simple elegant designs, his products define his vision and his personality.

Pep has accompanied us for many years now at Planning Sisplamo and now Made Design Barcelona guiding and teaching us, Pep considers this company his home away from home.

Pep Puerto entiende el diseño des de la parte más técnica hasta la estética del producto, su función y su utilidad.

El diseño sencillo y elegante de sus productos define su visión y personalidad.

Pep nos acompañó durante muchos años en Planning Sisplamo y Made Design Barcelona, guiándonos y enseñándonos. Un hombre que puede considerar esta empresa su casa.

Plumartis

Interlaken ⁶⁴



Plumartis is a design study funded in 2010 by Jordi Ventura and Bernat Faura, located in the beautiful Parc del Garraf, overlooking the city of Barcelona and the Mediterranean Sea.

We design and develop new products, focusing on the small details that bring value and innovation. Our experience in the engineering and industrial field gives us an integral vision of the product and it allows us to define the manufacturing processes needed, as well as the materials proposed.

At Plumartis we aim to reduce the environmental impact in every stage of the projects in which we participate, designing with this fundamental pillar in mind from conceptualisation to manufacturing.

Plumartis es un estudio fundado el 2010 por Jordi Ventura y Bernat Faura. Está ubicado en el Parque Natural del Garraf con vistas a la ciudad de Barcelona y al mar. Disfrutamos diseñando y desarrollando producto, centrándonos en los pequeños detalles que aportan valor e innovación al proyecto.

La dilatada experiencia en el ámbito industrial en sectores muy diversos, nos aporta una visión integral del producto al mismo tiempo que nos permite definir y aportar innovación tanto a nivel de los procesos productivos como de los materiales que confieren el producto.

En Plumartis trabajamos siempre para reducir el impacto ambiental de los productos y procesos en los que participamos, siendo éste apartado un pilar fundamental a la hora de conceptualizar y proyectar.

Roger Vancells

Baden ⁷⁰
Milano ¹¹⁶
Nyon ²⁰
Padova ¹⁴⁰



His Industrial Design education in ESDAP Llotja and Escola Massana, his work, both in product design and spaces, has the vocation of helping brand growth creating singular experiences that have emotional connections with users.

The working method has impact revealing the beauty of everyday objects making them simple, useful and clear, constantly innovating using truthful but also finding attractive solutions.

Formado como diseñador industrial en ESDAP Llotja y en Escola Massana, su trabajo, tanto en el diseño de producto como de espacios, tiene la vocación de ayudar al crecimiento de las marcas y conseguir generar experiencias singulares que tiendan conexiones emocionales con las personas que acaban utilizándolos.

El método de trabajo incide en conseguir revelar la belleza de las cosas cotidianas haciéndolas sencillas, funcionales y claras, utilizando para ello soluciones atractivas, sinceras y fruto de una mirada constante hacia la innovación.

Stone Designs

Berna ⁴⁰
Laax ⁹⁶
Bamboo ¹⁵⁸



Stone Designs is the story of two people (Cutu Mazuelos 1973 and Eva Prego 1974), and their career spanning over twenty-years. During this time they have developed a huge variety of projects, from a personal perspective and without censure. This approach has allowed Stone Designs to give expression to its essence in every challenge faced. All this makes Stone Designs a dedicated studio, with a passion for design and for life.

Stone Designs responde a la historia de sus dos creadores (Cutu Mazuelos 1973 y Eva Prego 1974), y sus más de veinte años de carrera. Tiempo en el que ha desarrollado multitud de proyectos desde una perspectiva personal, sin censura ni filtros. Este modo de afrontar su trabajo ha hecho que durante todo este tiempo, Stone Designs haya sido capaz de plasmar su esencia en cada uno de los proyectos a los que se ha enfrentado. Stone Designs es ya un estudio consolidado pero no por ello menos entregado a su actividad, que es a la vez su pasión y razón de su existencia.

Toni Arola

Lausanne ²⁸



Was born in Tarragona in 1960 and currently lives in Barcelona. He studied at Eina school in Barcelona, and in 1984 he began his professional career at Estudi Lievore i Pensi, and later at AD Associate Designers. In 1994 he founded Estudi Antoni Arola.

His projects are diverse: they go from lighting projects for various publishers such as Santa & Cole, Vibia, Viabizzuno, to pieces of furniture, perfume packaging, interior design and ephemeral installations.

His eternal and continuous research for beauty, inspired by ancestral cultures and his particular vision of light, gives him a unique versatility that filters through each and every project.

Among the awards he has won are the National Design Award in 2003, four times with a Silver Delta Award and in 2018 with a Red Dot: Best of The Best.

Nace en Tarragona en 1960 y actualmente vive en Barcelona. Estudió en la escuela Eina de Barcelona, en 1984 inicia su carrera profesional en el Estudio Lievore y Pensi, y posteriormente en AD Associate Designers. En el 1994 funda Estudi Antoni Arola.

Sus proyectos tocan campos muy diversos: proyectos de iluminación para diversas editoras como Santa&Cole, Vibia, Viabizzuno, piezas de mobiliario, envases de perfumes, proyectos de interiorismo e instalaciones efímeras.

Su eterna y continua búsqueda de la belleza, inspirada en las culturas ancestrales y en su particular visión de la luz, le confieren una versatilidad singular que filtra a través de cada proyecto.

Entre otros premios ha estado galardonado con el Premio Nacional de Diseño 2003, cuatro veces con un Premio Delta de Plata y en el año 2018 con un Red Dot: Best of The Best.

Toni Pallejà

Sapporo ¹⁸²



Toni Pallejà studied industrial design at the Eina school, Porcuatro where he teaches. After working in industrial design he now works in fashion design and accessories and is currently developing activities for several clients including Carpyen, Barcelona City Council, Decap, RNB Cosmetics and Apr Jané where he is creative director .

Toni Pallejà estudió diseño industrial en la escuela Eina, donde actualmente Porcuatro ejercen de docentes. Después de trabajar en estudios de diseño industrial y en el campo de diseño de complementos de moda, actualmente desarrolla su actividad para clientes como Carpyen, Ajuntament de Barcelona, Decap, Rnb Cosmetics, Jané o Abr donde se encarga de la dirección creativa.

Ximo Roca Design

Biel⁹⁰



Although his professional career began in 1981 it wasn't until 1989 that the Ximo Roca Design studio was established.

His work is characterized by an initial immersion in the reality of business helping him to understand the markets that they address. Analysis of their production systems, their capacity and their economic potential... thus he can offer each customer a service of realistic, concrete and specific design. The design will accommodate the market, and not the design. His desire is that his work will allow companies to compete in the market more competitively and this is one of his constant concerns.

His projects both national and international and ranging from industrial design, graphic design to interior design and architecture.

Aunque su trayectoria profesional se inició en 1981, fue en 1989 cuando se creó el estudio Ximo Roca Diseño.

Su trabajo se caracteriza por una inmersión inicial en la realidad empresarial de los clientes y por entender el mercado al que ellos se dirigen. Analiza sus sistemas de producción, su capacidad, su potencial económico... de este modo puede ofrecer un servicio de diseño realista, concreto y específico a cada cliente. El diseño se acomodará al mercado y no éste al diseño. Pretende que su trabajo permita a las empresas concurrir en el mercado más competitivamente y ésta es una de sus constantes preocupaciones.

Sus proyectos, tanto de ámbito nacional como internacional, abarcan desde el diseño industrial y el diseño gráfico al interiorismo y la arquitectura.

Technical Data

Recycling	236	Comfort	250
Baden	236	Adelaida	250
Basilea	237	Albury	251
Berna	238	Bamboo	252
Biel	239	Bergamo	253
Davos	240	Bologna	254
Ginebra	241	Capri	255
Interlaken	242	Kyoto	256
Laax	243	Menfis	257
Lausanne	244	Milano	258
Lugano	245	Nagoya	259
Nyon	246	Napoli	260
Vevey	247	Note-it	261
Zell	248	Osaka	262
Zurich	249	Padova	263
		Sapporo	264
		Siena	265
		Torino	266
		Treviso	267
		Vevey Acoustic	268
		Colour & finishes	269

Baden

by Grup Idea + Roger Vancells

RECYCLING

← VIEW PRODUCT PAGES

70

PHOTO



CHARACTERISTICS

Bin made from 1.5 mm sheet metal. Body unified by welding. Front swing door for the extraction of the inner bag. Lock with key included. It incorporates bag hoop inside the bin. Base includes rubber blocks to protect the surface where it is located. Vinyl residue indicator icon.

Papelera fabricada en chapa de hierro de 1,5 mm. Cuerpo unido mediante soldadura. Puerta batiente frontal para la extracción de la bolsa interior. Cerradura con llave incluida. Incorpora aro porta bolsa en el interior de la papelera. Base con tacos de goma para proteger la superficie donde se ubique. Icono indicador de residuo en vinilo.

Corbeille en tôle de 1,5 mm d'épaisseur. Corps uni par soudure. Porte battante avant pour l'extraction du sac intérieur. Serrure avec clé incluse. Elle intègre un anneau à l'intérieur pour maintenir le sac. Base avec des gommages de caoutchouc pour protéger la surface où elle se trouve. Icône d'indicateur de résidus en vinyle.

VERSIONS, SIZES AND WEIGHT

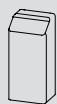

BDN 01

45 x 35,5 x 100 cm — 100 L
17,7 x 14 x 39,3 in. — 26,4 gal.
31 kg
68,3 lb.

ACCESSORIES

SB_system

More info at page 76

CUSTOMISE OPTIONS

 COLOUR

 PICTOGRAMS

COLOURS

 RAL 9003

 RAL 7016

VINYL COLOURS

 BLUE

 GREEN

 YELLOW

 GREY

 BROWN

 RED

ENVIRONMENTAL IMPACT

Materials may be easily disassembled to be recycled.

Materiales fácilmente segregables para su posterior reciclado.

Matériaux facilement démontables pour leurs recyclages.

FIRE RESISTANCE

UNE-EN 13501-1

A1-s1, d0

WARRANTY

Two (2) year limited warranty. Does not cover: incorrect use, bad handling or deliberate damage.

Garantía de dos (2) años limitada. No cubre: mal uso, manipulación o daños intencionados.

Garantie deux (2) ans. A l'exception: mauvaise utilisation, manipulation, dommages intentionnés.

PACKAGING

Cardboard box with plastic bag for product protection. One package.

Caja de cartón con bolsa de plástico para protección. Un paquete.

Boîte en carton avec sac plastique pour la protection. Un paquet.

Basilea

by Pep Puerto

RECYCLING

← VIEW PRODUCT PAGES

52

PHOTO





CHARACTERISTICS

Bin made of 1.2mm sheet metal. Front of bin slides forward for removal of rubbish. Built-in ABS, plastic handles on the side of the body for handling. 40 liter plastic inner tank (ZUR 50) included for the BAS 01 version. Ring for the bag included inside the bin for the BAS 10 version. Vinyl waste indicator icon.

Papelera fabricada en chapa de hierro de 1,2mm. Frontal o cuerpo extraíble. Asas empotradas de plástico ABS en el lateral del cuerpo para su manipulación. Cubeta de plástico interior de 40 litros (ZUR 50) incluida para la versión BAS 01. Aro para la bolsa incluido en el interior de la papelera para la versión BAS 10. Icono indicador de residuo en vinilo.

Corbeille fabriquée en tôle de 1,2 mm d'épaisseur. Partie frontale ou corps amovible. Poignées en plastique ABS intégrées sur le côté du corps pour sa manipulation. Réservoir intérieur en plastique de 40 litres (ZUR 50) inclus pour la version BAS 01. Anneau pour maintenir le sac inclus à l'intérieur de la corbeille pour la version BAS 10. Icône d'indicateur de déchets en vinyle.

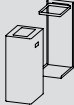





VERSIONS, SIZES AND WEIGHT

	BAS 01	24 x 35 x 70 cm — 40 L 9,4 x 13,8 x 27,6 in. — 10,6 gal. 7 kg 15,4 lb.		BAS 10	27 x 35 x 71 cm — 55 L 10,6 x 13,8 x 27,9 in. — 14,5 gal. 12 kg 26,5 lb.
	ZUR 50	28,5 x 21,5 x 69,4 cm — 40 L 11,2 x 8,5 x 27,3 in. — 10,6 gal. 1 kg 2,2 lb.			



COLOURS

 RAL 9003 + 7016

VINYL COLOURS

-  BLUE
-  GREEN
-  YELLOW
-  GREY
-  BROWN
-  RED

CUSTOMISE OPTIONS

-  COLOUR
-  PICTOGRAMS

ENVIRONMENTAL IMPACT

Materials may be easily disassembled to be recycled.

Materiales fácilmente segregables para su posterior reciclado.

Matériaux facilement démontables pour leurs recyclages.

FIRE RESISTANCE

UNE-EN 13501-1

A1-s1, d0

WARRANTY

Two (2) year limited warranty. Does not cover: incorrect use, bad handling or deliberate damage.

Garantía de dos (2) años limitada. No cubre: mal uso, manipulación o daños intencionados.

Garantie deux (2) ans. À l'exception: mauvaise utilisation, manipulation, dommages intentionnés.

PACKAGING

Cardboard box with plastic bag for product protection. One package.

Caja de cartón con bolsa de plástico para protección. Un paquete.

Boîte en carton avec sac plastique pour la protection. Un paquet.

PHOTO



CHARACTERISTICS

Recycling bin made of 1.5 mm sheet metal. The hinged lid is attached to the body with 2 non visible screws. Hoop ring to hold the rubbish bag included inside the bin. The base body body unified seamlessly by welding. Base fitted with rubber blocks to protect the surface where it is located. Vinyl residue indicator icon.

Papelera fabricada en chapa de hierro de 1,5 mm. La tapa batiente está sujeta al cuerpo de la papelera mediante 2 tornillos no visibles. Aro para sujetar la bolsa tipo mariposa incluido en el interior de la papelera. Unión de la base con el cuerpo de la papelera mediante soldadura. Base con tacos de goma para proteger la superficie donde se ubique. Icono indicador de residuo en vinilo.

Corbeille fabriquée en tôle de 1,5 mm d'épaisseur. Le couvercle à charnière est fixé au corps de la poubelle à l'aide de 2 vis non visibles. Anneau pour maintenir le sac de type papillon inclus à l'intérieur de la corbeille. Union de la base et du corps de la corbeille soudé. Base avec des gommages de caoutchouc pour protéger la surface où elle se trouve. Icône d'indicateur de résidus en vinyle.

VERSIONS, SIZES AND WEIGHT



BER 02 T

25 x 25 x 70 cm — 39,4 L
9,8 x 9,8 x 27,6 in. — 10,5 gal.
9,4 kg
20,7 lb.



BER 03 T

35 x 35 x 100 cm — 100 L
13,8 x 13,8 x 39,4 in. — 26,4 gal.
18,7 kg
41,2 lb.

CUSTOMISE OPTIONS

 COLOUR

 PICTOGRAMS

 HOLE ON LID

COLOURS

 RAL 9003 + 3027

 RAL 9003 + 1023

 RAL 9003 + 6016

 RAL 9003 + 5012

 RAL 9003 + 8016

ENVIRONMENTAL IMPACT

Materials may be easily disassembled to be recycled.

Materiales fácilmente segregables para su posterior reciclado.

Matériaux facilement démontables pour leurs recyclages.

FIRE RESISTANCE

UNE-EN 13501-1

A1-s1, d0

WARRANTY

Two (2) year limited warranty. Does not cover: incorrect use, bad handling or deliberate damage.

Garantía de dos (2) años limitada. No cubre: mal uso, manipulación o daños intencionados.

Garantie deux (2) ans. À l'exception: mauvaise utilisation, manipulation, dommages intentionnés.

PACKAGING

Cardboard box with plastic bag for product protection. One package.

Caja de cartón con bolsa de plástico para protección. Un paquete.

Boîte en carton avec sac plastique pour la protection. Un paquet.

Biel

by Ximo Roca Diseño

RECYCLING

← VIEW PRODUCT PAGES

90

PHOTO



CHARACTERISTICS

Bin made using polypropylene injection. Manufactured in two coloured plastic pieces with an inner sheet metal disk weighing 400 grams to give stability to the base of the bin.

Papelera fabricada en inyección de polipropileno. Fabricada en dos piezas plásticas de color con disco interior de chapa de hierro de 400 gramos de peso para darle estabilidad a la base de la papelera.

Corbeille fabriquée en injection de polypropylène. Fabriquée en deux pièces de plastique colorées avec un disque intérieur en tôle de 400 grammes pour donner une stabilité à la base de la corbeille.

VERSIONS, SIZES AND WEIGHT



BIE 01

Ø30 x 36 cm — 18 L
Ø11,8 x 14,2 in. — 4,8 gal.
1,6 kg
3,5 lb.

COLOURS

 RAL 9003

 RAL 5012

 RAL 2003

 RAL 9011

CUSTOMISE OPTIONS

 COLOUR

 LOGOTYPE

ENVIRONMENTAL IMPACT

Made from 100% recyclable Type 5 plastic.

Fabricado en plástico Tipo 5 (PP) 100% reciclable.

Fabriqu  en plastique Typo 5 (PP) 100% recyclable.

FIRE RESISTANCE

UNE-EN 13501-1

B-s1, d1

WARRANTY

Two (2) year limited warranty. Does not cover: incorrect use, bad handling or deliberate damage.

Garant a de dos (2) a os limitada. No cubre: mal uso, manipulaci n o da os intencionados.

Garantie deux (2) ans.   l'exception: mauvaise utilisation, manipulation, dommages intentionn s.

PACKAGING

Cardboard box with plastic bag for product protection. One package.

Caja de cart n con bolsa de pl stico para protecci n. Un paquete.

Bo te en carton avec sac plastique pour la protection. Un paquet.

PHOTO



CHARACTERISTICS

Bin made of 1.2 mm sheet metal. Tilting lid attached to the body of the bin using two hinges. The ring to hold the bag hangs from the lid. The base is welded to the body of the bin unifying both elements seamlessly. The base includes holes for drainage. Rubber blocks attached to base to protect the surface where it is located. Vinyl residue indicator icon.

Papelera fabricada en chapa de hierro de 1,2 mm. Tapa basculante sujeta al cuerpo de la papelera con dos bisagras. El aro para sujetar la bolsa cuelga de la tapa. Unión de la base con el cuerpo de la papelera mediante soldadura. La base incluye agujeros para el desagüe. Base con tacos de goma para proteger la superficie donde se ubique. Icono indicador de residuo en vinilo.

Corbeille fabriquée en tôle de 1,2 mm d'épaisseur. Couvercle inclinable fixé au corps de la corbeille avec deux charnières. L'anneau pour tenir le sac est suspendu au couvercle. Union de la base et du corps de la corbeille soudé. La base comprend des trous pour le drainage. Base munie de gommages de caoutchouc pour protéger la surface où elle se trouve. Icône d'indicateur de résidus en vinyle.



VERSIONS, SIZES AND WEIGHT







DVS 01

30 x 30 x 73 cm — 52 L
11,8 x 11,8 x 28,7 in. — 13,7 gal.
14 kg
30,9 lb.

CUSTOMISE OPTIONS

-  COLOUR
-  PICTOGRAMS
-  HEIGHT & WIDTH

COLOURS

-  RAL 9003 + 3027
-  RAL 9003 + 6018
-  RAL 9003 + 1016
-  RAL 9003 + 5012

ENVIRONMENTAL IMPACT

Materials may be easily disassembled to be recycled.

Materiales fácilmente segregables para su posterior reciclado.

Matériaux facilement démontables pour leurs recyclages.

FIRE RESISTANCE

UNE-EN 13501-1

A1-s1, d0

WARRANTY

Two (2) year limited warranty. Does not cover: incorrect use, bad handling or deliberate damage.

Garantía de dos (2) años limitada. No cubre: mal uso, manipulación o daños intencionados.

Garantie deux (2) ans. À l'exception: mauvaise utilisation, manipulation, dommages intentionnés.

PACKAGING

Cardboard box with plastic bag for product protection. One package.

Caja de cartón con bolsa de plástico para protección. Un paquete.

Boîte en carton avec sac plastique pour la protection. Un paquet.

Ginebra

by Pascual Salvador

RECYCLING

← VIEW PRODUCT PAGES

84

PHOTO



CHARACTERISTICS

Bin made from 0.8mm Plakene and foamed 4mm PVC. Base in 0.8 mm sheet metal. The main body and construction elements unified using 8 nylon clips and plastic rivets.



Papelera fabricada en Plakene de 0,8 mm y PVC espumado de 4 mm. Base en chapa de acero de 0,8 mm. Unión entre el cuerpo y elementos constructivos mediante 8 clips de nylon y remaches plásticos.



Corbeille fabriquée en Plakene de 0,8 mm d'épaisseur et en PVC expansé de 4 mm. Base en tôle d'acier de 0,8 mm. Union entre le corps et les éléments constructifs grâce à 8 pinces en nylon et rivets en plastique.

VERSIONS, SIZES AND WEIGHT

	GIN 01	Ø33 x 43 cm — 18 L Ø13 x 16,9 in. — 4,8 gal. 0,6 kg 1,3 lb.		GIN 02	Ø33 x 34 cm — 10 + 10 L Ø13 x 13,4 in. — 2,6 + 2,6 gal. 0,7 kg 1,5 lb.
	GIN 03	Ø33 x 34 cm — 6 + 13 L Ø13 x 13,4 in. — 1,6 + 3,4 gal. 0,8 kg 1,8 lb.			

COLOURS

-  BL · PLAKENE · P000
-  AZ · PLAKENE · P100

-  VD · PLAKENE · P208
-  NJ · PLAKENE · P440

-  AM · PLAKENE · P706

CUSTOMISE OPTIONS

-  COLOUR

ENVIRONMENTAL IMPACT

Made from 100% recyclable Type 5 plastic.

Fabricado en plástico Tipo 5 (PP) 100% reciclable.

Fabriqué en plastique Typo 5 (PP) 100% recyclable.

FIRE RESISTANCE

UNE-EN 13501-1

B-s1, d1

WARRANTY

Two (2) year limited warranty. Does not cover: incorrect use, bad handling or deliberate damage.

Garantía de dos (2) años limitada. No cubre: mal uso, manipulación o daños intencionados.

Garantie deux (2) ans. À l'exception: mauvaise utilisation, manipulation, dommages intentionnés.

PACKAGING

Cardboard box with plastic bag for product protection. One package.

Caja de cartón con bolsa de plástico para protección. Un paquete.

Boîte en carton avec sac plastique pour la protection. Un paquet.

Interlaken

by Plumartis

RECYCLING

← VIEW PRODUCT PAGES

64

PHOTO



CHARACTERISTICS

Bin made of 1.2mm sheet metal. Removable lid. Hoop to hold the bag included inside the bin. Base and body of bin unified by welding. Base included rubber blocks to protect the surface where it is located.

Papelera fabricada en chapa de hierro de 1,2 mm. Tapa extraíble. Aro para sujetar la bolsa tipo mariposa incluido en el interior de la papelera. Unión de la base con el cuerpo de la papelera mediante soldadura. Base con tacos de goma para proteger la superficie donde se ubique.

Corbeille fabriquée en tôle de 1,2 mm. Couvercle amovible. Anneau pour maintenir le sac de type papillon inclus à l'intérieur de la corbeille. Union de la base et du corps de la corbeille soudé. Base avec des gommages de caoutchouc pour protéger la surface où elle se trouve.

VERSIONS, SIZES AND WEIGHT



INT 01 A/B/C/D

40 x 20 x 35 cm — 24,7 L
17,7 x 7,9 x 13,8 in. — 6,5 gal.
7,4 kg
16,3 lb.



INT 02 A/B/C/D

40 x 20 x 45 cm — 32,7 L
17,7 x 7,9 x 17,7 in. — 8,6 gal.
8,7 kg
19,2 lb.



INT 03 A/B/C/D

40 x 20 x 55 cm — 40,7 L
17,7 x 7,9 x 21,7 in. — 10,8 gal.
10 kg
22 lb.



INT 04 A/B/C/D

40 x 20 x 65 cm — 48,7 L
17,7 x 7,9 x 25,6 in. — 12,9 gal.
11,3 kg
24,9 lb.

LID OPTIONS



A - PLASTIC



B - PAPER



C - GLASS



D - WASTE

CUSTOMISE OPTIONS



COLOUR



HOLE ON LID

COLOURS



RAL 9003 + 1023



RAL 9003 + 5012



RAL 9003 + 6016



RAL 9003 + 8016

ENVIRONMENTAL IMPACT

Materials may be easily disassembled to be recycled.

Materiales fácilmente segregables para su posterior reciclado.

Matériaux facilement démontables pour leurs recyclages.

FIRE RESISTANCE

UNE-EN 13501-1

A1-s1, d0

WARRANTY

Two (2) year limited warranty. Does not cover: incorrect use, bad handling or deliberate damage.

Garantía de dos (2) años limitada. No cubre: mal uso, manipulación o daños intencionados.

Garantie deux (2) ans. À l'exception: mauvaise utilisation, manipulation, dommages intentionnés.

PACKAGING

Cardboard box with plastic bag for product protection. One package.

Caja de cartón con bolsa de plástico para protección. Un paquete.

Boîte en carton avec sac plastique pour la protection. Un paquet.

PHOTO



CHARACTERISTICS

Ashtray made of 3.2mm thick iron tube. Removable head for emptying ashes. The head is fixed to the body using an allen key included. Fixed to floor using screws. The mouth of the ashtray is made from stainless steel.

Cenicero fabricado en tubo de hierro de 3,2 mm de grosor. Cabezal extraíble para el vaciado de la cubeta interior. El cabezal se fija al cuerpo mediante llave allen incluida. Fijación a suelo mediante tornillos. La boca del cenicero fabricada en chapa de acero inoxidable.

Cendrier en tube de fer de 3,2 mm d'épaisseur. Partie supérieure amovible pour vider le bac intérieur. La partie supérieure est fixée au corps avec une clé Allen incluse. Fixation au sol avec des vis. L'orifice du cendrier est fabriqué en tôle d'acier inoxydable.

VERSIONS, SIZES AND WEIGHT



LAX 01

Ø21 x 100 cm
Ø8,3 x 39,4 in.
8 kg
17,6 lb.
Tube: Ø8,8 cm / Ø3,4 in.

COLOURS

 RAL 9003

 RAL 9006

 RAL 7016

CUSTOMISE OPTIONS

 COLOUR

ENVIRONMENTAL IMPACT

Materials may be easily disassembled to be recycled.

Materiales fácilmente segregables para su posterior reciclado.

Matériaux facilement démontables pour leurs recyclages.

FIRE RESISTANCE

UNE-EN 13501-1

A1-s1, d0

WARRANTY

Two (2) year limited warranty. Does not cover: incorrect use, bad handling or deliberate damage.

Garantía de dos (2) años limitada. No cubre: mal uso, manipulación o daños intencionados.

Garantie deux (2) ans. À l'exception: mauvaise utilisation, manipulation, dommages intentionnés.

PACKAGING

Cardboard box with plastic bag for product protection. One package.

Caja de cartón con bolsa de plástico para protección. Un paquete.

Boîte en carton avec sac plastique pour la protection. Un paquet.

Lausanne

by Toni Arola

RECYCLING

← VIEW PRODUCT PAGES

28

PHOTO



CHARACTERISTICS

Base and top made of cast aluminum and body in 1.5 mm steel or deployé. Unified using rivets. Depending on which model, a piece of repulsed aluminum is placed to act as a wastepaper basket or ashtray-bin. Between the embellisher and the lid a ring is placed to hold the bag.

Base y cabezal de fundición de aluminio y cuerpo en plancha de acero de 1,5 mm o chapa de hierro deployé. Unión de las 3 partes mediante remaches. Según modelo, se coloca una pieza de aluminio repulsado para hacer la función de papelera o cenicero-papelera. Entre el embellecedor y el cabezal se sitúa un aro para sujetar la bolsa.

Base et partie supérieure en fonte d'aluminium et corps en tôle d'acier de 1,5 mm d'épaisseur ou en métal déployé. Union des 3 pièces à l'aide de rivets. Selon le modèle, un morceau d'aluminium repoussé est placé pour servir de corbeille à papier ou de cendrier. Un anneau est placé entre l'embellisseur et la partie supérieure pour maintenir le sac.

VERSIONS, SIZES AND WEIGHT

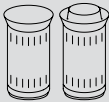

LSN 01

LSN 02

Ø45 x 80 cm — 120 L
Ø17,7 x 33,1 in. — 26,4 gal.
21 kg
46,3 lb.

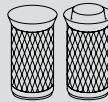

LSN 01D

LSN 02D

Ø45 x 80 cm — 120 L
Ø17,7 x 33,1 in. — 26,4 gal.
14 kg
30,9 lb.

D: Deployé version

CUSTOMISE OPTIONS

 BODY COLOUR

COLOURS

 RAL 7016

 RAL 9006

 INOX

 D - RAL 7016

 D - RAL 9006

ENVIRONMENTAL IMPACT

Materials may be easily disassembled to be recycled.

Materiales fácilmente segregables para su posterior reciclado.

Matériaux facilement démontables pour leurs recyclages.

FIRE RESISTANCE

UNE-EN 13501-1

A1-s1, d0

WARRANTY

Two (2) year limited warranty. Does not cover: incorrect use, bad handling or deliberate damage.

Garantía de dos (2) años limitada. No cubre: mal uso, manipulación o daños intencionados.

Garantie deux (2) ans. À l'exception: mauvaise utilisation, manipulation, dommages intentionnés.

PACKAGING

Cardboard box with plastic bag for product protection. One package.

Caja de cartón con bolsa de plástico para protección. Un paquete.

Boîte en carton avec sac plastique pour la protection. Un paquet.

PHOTO



CHARACTERISTICS

Bin made from 1.2 mm sheet metal. The base and body of the bin unified by welding. Base includes rubber blocks to protect the surface where it is located. Includes protective rubber on the front opening of 35 mm to protect the surface where it hangs.

Papelera fabricada en chapa de hierro de 1,2 mm. Unión de la base con el cuerpo de la papelera mediante soldadura. Base con tacos de goma para proteger la superficie donde se ubique. Incluye goma protectora en la apertura frontal de 35 mm para proteger la superficie donde se encaja.

Corbeille fabriquée en tôle de 1,2 mm d'épaisseur. Union de la base et du corps de la corbeille soudé. Base avec des gommages de caoutchouc pour protéger la surface où elle se trouve. Comprend un caoutchouc de protection sur l'ouverture frontale de 35 mm d'épaisseur pour protéger la superficie où elle se trouvera.

VERSIONS, SIZES AND WEIGHT



LUG 01

18,8 x 18,8 x 30 cm — 8 L
7,4 x 7,4 x 11,8 in. — 2,1 gal.
4 kg
8,8 lb.

COLOURS

RAL 9003

CUSTOMISE OPTIONS

COLOUR

PICTOGRAMS

ENVIRONMENTAL IMPACT

Materials may be easily disassembled to be recycled.

Materiales fácilmente segregables para su posterior reciclado.

Matériaux facilement démontables pour leurs recyclages.

FIRE RESISTANCE

UNE-EN 13501-1

A1-s1, d0

WARRANTY

Two (2) year limited warranty. Does not cover: incorrect use, bad handling or deliberate damage.

Garantía de dos (2) años limitada. No cubre: mal uso, manipulación o daños intencionados.

Garantie deux (2) ans. À l'exception: mauvaise utilisation, manipulation, dommages intentionnés.

PACKAGING

Cardboard box with plastic bag for product protection. One package.

Caja de cartón con bolsa de plástico para protección. Un paquete.

Boîte en carton avec sac plastique pour la protection. Un paquet.

PHOTO



CHARACTERISTICS

Bin consisting of two cylinders made of 1.5 mm sheet metal and a 4 mm lid. The outer cylinder is decorative and can be replaced by wooden slats. The inner cylinder serves to hold the bag. The base and body of the bin unified by welding. Base supplied with rubber blocks to protect the surface where it is located.

Papelera compuesta de dos cilindros fabricados en chapa de hierro de 1,5 mm y una tapa de hierro de 4 mm. El cilindro exterior es decorativo y puede ser substituido por lamas de madera. El cilindro interior sirve para sujetar la bolsa. Unión de la base con el cuerpo de la papelera mediante soldadura. Base con tacos de goma para proteger la superficie donde se ubique.

Corbeille composée de deux cylindres en tôle d'1,5 mm d'épaisseur et d'un couvercle en fer de 4 mm. Le cylindre extérieur est décoratif et peut être remplacé par des lattes de bois. Le cylindre intérieur sert à tenir le sac. Union de la base et du corps de la corbeille soudé. Base avec des gommés de caoutchouc pour protéger la surface où elle se trouve.

VERSIONS, SIZES AND WEIGHT

	NYO 10 / 10C NYO 12 / 12C NYO 14 / 14C	Ø44 x 84 cm — 80 L Ø17,2 x 32,8 in. — 21 gal. 20 kg 44,1 lb. C: Ashtray option		NYO 18 / 18C	Ø44 x 84 cm — 80 L Ø17,2 x 32,8 in. — 21 gal. 27,9 kg 61,5 lb. C: Ashtray option
	NYO 20 NYO 22 NYO 24	Ø23 x 44 cm — 12 L Ø9 x 17,9 in. — 3,2 gal. 5,5 kg 12,1 lb.		NYO 50 NYO 52 NYO 54	Ø23 x 44 cm Ø9 x 17,3 in. 5,5 kg 12,1 lb.
	NYO 60 NYO 62 NYO 64	Ø17 x 87,8 cm Ø6,7 x 34,6 in. 6 kg 13,2 lb.			

TEXTURE

0 - ORGANIC	2 - LINEAR	4 - CLASSIC	8 - WOOD
-------------	------------	-------------	----------

CUSTOMISE OPTIONS

- COLOUR
- PATTERN
- LOGOTYPE

COLOURS

- RAL 9003 + RAL 7016
- RAL 7016 + RAL 7016
- OXI + RAL 7016
- WOOD + RAL 7016

ENVIRONMENTAL IMPACT

Materials may be easily disassembled to be recycled.

Materiales fácilmente segregables para su posterior reciclado.

Matériaux facilement démontables pour leurs recyclages.

FIRE RESISTANCE

UNE-EN 13501-1

NYO 10 / 12 / 14
NYO 18
NYO 20 / 22 / 24
NYO 50 / 52 / 54
NYO 60 / 62 / 64

A1-s1, d0
D-s2, d0
A1-s1, d0
A1-s1, d0
A1-s1, d0

WARRANTY

Two (2) year limited warranty. Does not cover: incorrect use, bad handling or deliberate damage.

Garantía de dos (2) años limitada. No cubre: mal uso, manipulación o daños intencionados.

Garantie deux (2) ans. À l'exception: mauvaise utilisation, manipulation, dommages intentionnés.

PACKAGING

Cardboard box with plastic bag for product protection. One package.

Caja de cartón con bolsa de plástico para protección. Un paquete.

Boîte en carton avec sac plastique pour la protection. Un paquet.

PHOTO



CHARACTERISTICS

Bin made of 1.2 mm sheet metal with two sides (front and back) in thermoformed high impact polystyrene 3 mm thick. It is shipped disassembled. Simple assembly with 8 butterfly screws. Removable lid. Internal ring to hold the bag in 3 mm sheet metal. Base supplied with rubber blocks to protect the surface where it is located. Vinyl residue indicator icon.

Papelera fabricada en chapa de hierro de 1,2 mm con dos caras (frontal y trasera) en poliestireno de alto impacto termoconformado de 3 mm de grosor. Se envía desmontada. Ensamblaje sencillo mediante 8 tornillos mariposa. Tapa extraíble. Aro interior para sujetar la bolsa en chapa de hierro de 3 mm de grosor. Base con tacos de goma para proteger la superficie donde se ubique. Icono indicador de residuo en vinilo.

Corbeille fabriquée en tôle d'acier de 1,2 mm d'épaisseur avec deux côtés (avant et arrière) en polystyrène thermoformé résistant aux chocs, épaisseur 3 mm. Il est expédié démonté. Assemblage simple avec 8 vis papillon. Couverture amovible. Anneau interne pour tenir le sac en tôle de 3 mm d'épaisseur. Base avec des gommages de caoutchouc pour protéger la surface où elle se trouve. Icône d'indicateur de résidu en vinyle.

VERSIONS, SIZES AND WEIGHT

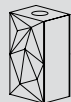







VVY 01

41 x 34 x 73 cm — 86 L
16,1 x 13,4 x 28,7 in. — 22,7 gal.
10 kg
22 lb.



COLOURS

 RAL 9003

VINYL COLOURS

 BLUE
 GREEN
 YELLOW
 GREY
 BROWN
 RED

CUSTOMISE OPTIONS

 COLOUR
 PICTOGRAMS

ENVIRONMENTAL IMPACT

Materials may be easily disassembled to be recycled.

Materiales fácilmente segregables para su posterior reciclado.

Matériaux facilement démontables pour leurs recyclages.

FIRE RESISTANCE

UNE-EN 13501-1

B-s1, d1

WARRANTY

Two (2) year limited warranty. Does not cover: incorrect use, bad handling or deliberate damage.

Garantía de dos (2) años limitada. No cubre: mal uso, manipulación o daños intencionados.

Garantie deux (2) ans. À l'exception: mauvaise utilisation, manipulation, dommages intentionnés.

PACKAGING

Cardboard box with plastic bag for product protection. One package.

Caja de cartón con bolsa de plástico para protección. Un paquete.

Boîte en carton avec sac plastique pour la protection. Un paquet.

PHOTO



CHARACTERISTICS

Bin made from 1.5 mm sheet metal. Unified by welding. The hinged lid is attached to the trash can body with 2 non visible screws. 40 liter plastic inner trays (ZUR 50) included. Base includes rubber blocks to protect the surface where it is located. Vinyl residue indicator icon.

The version with hinged doors, incorporates ring to hold the bag.

Papelera fabricada en chapa de hierro de 1,5 mm. Cuerpo unido mediante soldadura. La tapa batiente está sujeta al cuerpo de la papelera mediante 2 tornillos no visibles. Cubetas de plástico interiores de 40 litros (ZUR 50) incluidas. Base con tacos de goma para proteger la superficie donde se ubique. Icono indicador de residuo en vinilo.

La versión con puertas batientes, incorpora aro para sujetar la bolsa.

Corbeille fabriquée en tôle de 1,5 mm d'épaisseur. Corps uni par soudure. Le couvercle à charnière est fixé au corps de la poubelle à l'aide de 2 vis non visibles. Bacs intérieurs en plastique de 40 litres (ZUR 50) inclus. Base avec des gommages de caoutchouc pour protéger la surface où elle se trouve. Icône d'indicateur de résidus en vinyle.

La version à portes battantes comprend un anneau pour maintenir le sac.

VERSIONS, SIZES AND WEIGHT

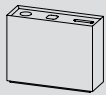

ZEL 03

95 x 32 x 75 cm — 120 L
37,4 x 12,6 x 29,5 in. — 31,7 gal.
28 kg
61,7 lb.
3x ZUR 50 Included

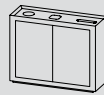

ZEL 03P

95 x 32 x 75 cm — 120 L
37,4 x 12,6 x 29,5 in. — 31,7 gal.
32 kg
70,5 lb.
P: Door version

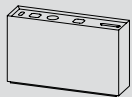

ZEL 05

125 x 32 x 75 cm — 160 L
49,2 x 12,6 x 29,5 in. — 42,3 gal.
35 kg
77,2 lb.
4x ZUR 50 Included



ZUR 50

28,5 x 21,5 x 69,4 cm — 40 L
11,2 x 8,5 x 27,3 in. — 10,6 gal.
1 kg
2,2 lb.

CUSTOMISE OPTIONS

- COLOUR
- PICTOGRAMS
- HEIGHT & WIDTH
- HOLE ON LID

COLOURS

- RAL 9003
- INOX

VINYL COLOURS

- BLUE
- GREEN
- YELLOW
- GREY
- BROWN
- RED

ENVIRONMENTAL IMPACT

Materials may be easily disassembled to be recycled.

Materiales fácilmente segregables para su posterior reciclado.

Matériaux facilement démontables pour leurs recyclages.

FIRE RESISTANCE

UNE-EN 13501-1

A1-s1, d0

WARRANTY

Two (2) year limited warranty. Does not cover: incorrect use, bad handling or deliberate damage.

Garantía de dos (2) años limitada. No cubre: mal uso, manipulación o daños intencionados.

Garantie deux (2) ans. A l'exception: mauvaise utilisation, manipulation, dommages intentionnés.

PACKAGING

Cardboard box with plastic bag for product protection. One package.

Caja de cartón con bolsa de plástico para protección. Un paquete.

Boîte en carton avec sac plastique pour la protection. Un paquet.

PHOTO



CHARACTERISTICS

Bin made of 0.8 mm sheet metal. The model ZUR 01 and 02 assembled using rivets, including injected polycarbonate hinged cover. The ZUR 03 welded in one piece with 1.5 mm sheet metal lid. Inner ring to hold bag included inside. Base includes rubber blocks to protect the surface where it is located. Vinyl residue indicator icon

Papelera fabricada en chapa de hierro de 0,8 mm. El modelo ZUR 01 y 02 ensamblado mediante remaches, con tapa de policarbonato inyectado batiente. La ZUR 03 soldada en una pieza con tapa de chapa de hierro de 1,5 mm. Aro para sujetar la bolsa tipo mariposa incluido en el interior. Base con tacos de goma para proteger la superficie donde se ubique. Icono indicador de residuo en vinilo.

Corbeille fabriquée en tôle de 0,8 mm d'épaisseur. Les modèles ZUR 01 et 02 sont assemblés avec des rivets, et muni d'un couvercle articulé en polycarbonate injecté. La ZUR 03 est soudée d'une seule pièce avec un couvercle en tôle de 1,5 mm d'épaisseur. Anneau pour tenir le sac de type papillon inclus à l'intérieur. Base avec des gommages de caoutchouc pour protéger la surface où elle se trouve. Icône d'indicateur de résidu en vinyle.

VERSIONS, SIZES AND WEIGHT

	ZUR 01	24 x 35 x 71 cm — 55 L 9,4 x 13,8 x 28 in. — 14,5 gal. 21 kg 46,3 lb.		ZUR 02	24 x 35 x 40 cm — 30 L 9,4 x 13,8 x 15,7 in. — 7,9 gal. 15,8 kg 34,8 lb.
	ZUR 03	39 x 29 x 98 cm — 110 L 15,4 x 11,4 x 38,6 in. — 29,1 gal. 20 kg 44,1 lb.		ZUR 50	28,5 x 21,5 x 69,4 cm — 40 L 11,2 x 8,5 x 27,3 in. — 10,6 gal. 1 kg 2,2 lb.

ACCESSORIES

	ZUR 30 Sign Rotulo Étiquette		ZUR 31 Vinyl Vinilo Vinyle		ZUR 40 Wheels Ruedas Roulettes
--	--	--	--	--	--

COLOURS

	RAL 9006		RAL 1023		RAL 6016
	INOX		RAL 5012		

CUSTOMISE OPTIONS

- COLOUR
- PICTOGRAMS
- HOLE ON LID

ENVIRONMENTAL IMPACT

Materials may be easily disassembled to be recycled. *Materiales fácilmente separables para su posterior reciclado. Matériaux facilement démontables pour leurs recyclages.*

FIRE RESISTANCE

UNE-EN 13501-1
ZUR 01
ZUR 02
ZUR 03
B-s1, d1
B-s1, d1
A1-s1, d0

WARRANTY

Two (2) year limited warranty. Does not cover: incorrect use, bad handling or deliberate damage. *Garantía de dos (2) años limitada. No cubre: mal uso, manipulación o daños intencionados. Garantie deux (2) ans. À l'exception: mauvaise utilisation, manipulation, dommages intentionnés.*

PACKAGING

Cardboard box with plastic bag for product protection. One package. *Caja de cartón con bolsa de plástico para protección. Un paquete. Boîte en carton avec sac plastique pour la protection. Un paquet.*

Adelaida

by Lluís Porqueras

COMFORT

← VIEW PRODUCT PAGES

188

PHOTO





CHARACTERISTICS

Shelving, 19 mm thick MDF wooden shelves and folded stainless steel supports. Unification between support and shelves by fitting the brackets into the grooves in the wooden shelves. Attached to the wall using rawlplugs and screws.

Estantería compuesta por estantes de madera de MDF de 19 mm de grosor y soportes de acero inoxidable doblados. Unión entre soporte y estante mediante encaje de los soportes en las ranuras que presenta la madera. Fijación a pared mediante tacos y tornillos.

Etagère composée de tablette de bois en MDF de 19 mm d'épaisseur et de supports courbés en acier inoxydable. Union entre les supports et les tablettes en encastrant les supports dans les rainures que présentent les tablettes en bois. Fixation au mur à l'aide de chevilles et de vis.

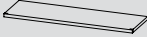
VERSIONS, SIZES AND WEIGHT

	ADL 01	80 x 25 x 1,9 cm 31,5 x 9,8 x 0,7 in. 2,7 kg 6 lb.	Shelf		ADL 11	2 x 25 x 41,2 cm 0,8 x 9,8 x 16,2 in. 1,8 kg 4 lb.	Side bracket
	ADL 12	4 x 25 x 41,2 cm 1,6 x 9,8 x 16,2 in. 1,8 kg 4 lb.	Central bracket				

CUSTOMISE OPTIONS

 COLOUR

COLOURS

RAL 9003

RAL 9011

ENVIRONMENTAL IMPACT

Materials may be easily disassembled to be recycled.

Materiales fácilmente segregables para su posterior reciclado.

Matériaux facilement démontables pour leurs recyclages.

FIRE RESISTANCE

UNE-EN 13501-1

D-s2, d0

WARRANTY

Two (2) year limited warranty. Does not cover: incorrect use, bad handling or deliberate damage.

Garantía de dos (2) años limitada. No cubre: mal uso, manipulación o daños intencionados.

Garantie deux (2) ans. A l'exception: mauvaise utilisation, manipulation, dommages intentionnés.

PACKAGING

Cardboard box with plastic bag for product protection. One package.

Caja de cartón con bolsa de plástico para protección. Un paquete.

Boîte en carton avec sac plastique pour la protection. Un paquet.

PHOTO



CHARACTERISTICS

Shelves composed of modular structures of 2mm iron of different heights. Assembled by screws at the bottom and metal threads at the top. Supported on the ground and fixed to the wall using rawlplugs and screws. It is necessary to assemble an even number of shelves to achieve balance. Horizontal wall version attached to the wall using screws and rawlplugs.

Estantería compuesta de estructuras modulares de chapa de hierro de 2 mm y de diferente altura. Ensamblada mediante tornillos en la parte inferior y roscas metálicas en la parte superior. Apoyada al suelo y fijada a pared mediante tacos y tornillos. Es necesario ensamblar un número par de estructuras. Versión mural horizontal fijada a pared mediante tornillos.

Etagère composée de structures modulaires en tôle de 2 mm d'épaisseur et de différentes hauteurs. Assemblée avec des vis en partie inférieure et des boulons métalliques en partie haute. Supportée au sol et fixée au mur à l'aide de chevilles et de vis. Il est nécessaire d'assembler un nombre pair de structures. Version murale horizontale fixée au mur à l'aide de vis.

VERSIONS, SIZES AND WEIGHT

	ALB 03	21 x 28 x 112 cm 8,3 x 11 x 44,1 in. 7,5 kg 16,5 lb.			ALB 04	21 x 28 x 147,4 cm 8,3 x 11 x 58 in. 9,2 kg 20,3 lb.	
	ALB 05	21 x 28 x 172,8 cm 8,3 x 11 x 68 in. 12,6 kg 27,8 lb.			ALB 06	21 x 28 x 198,2 cm 8,3 x 11 x 78 in. 15 kg 33,1 lb.	
	ALB 20	152 x 24 x 21 cm 59,8 x 9,4 x 8,3 in. 10,5 kg 23,1 lb.					
	ALB 10	21 x 28 x 4 cm 8,3 x 11 x 1,6 in. 1,5 kg 3,3 lb.	Magnetic shelf		ALB 11	21 x 24 x 4 cm 8,3 x 9,4 x 1,6 in. 1,5 kg 3,3 lb.	Magnetic shelf

COLOURS

RAL 9003

RAL 7016

CUSTOMISE OPTIONS

COLOUR

ENVIRONMENTAL IMPACT

Materials may be easily disassembled to be recycled.

Materiales fácilmente separables para su posterior reciclado.

Matériaux facilement démontables pour leurs recyclages.

FIRE RESISTANCE

UNE-EN 13501-1

A1-s1, d0

WARRANTY

Two (2) year limited warranty. Does not cover: incorrect use, bad handling or deliberate damage.

Garantía de dos (2) años limitada. No cubre: mal uso, manipulación o daños intencionados.

Garantie deux (2) ans. À l'exception: mauvaise utilisation, manipulation, dommages intentionnés.

PACKAGING

Cardboard box with plastic bag for product protection. One package.

Caja de cartón con bolsa de plástico para protección. Un paquete.

Boîte en carton avec sac plastique pour la protection. Un paquet.

Bamboo

by Stone Designs

COMFORT

← VIEW PRODUCT PAGES

158

PHOTO



CHARACTERISTICS

Acoustic wall panel made from thermo-formed polyester coloured felt. Absorbes ambient sound thanks to the shape of the acoustic panel, the empty interior space and the sound absorbing material. Fixed to the wall using a magnetic system.

Panel acústico mural fabricado en fieltro de colores de poliéster termoconformado. Absorción del sonido ambiente gracias a la forma del panel acústico, el espacio vacío interior y el material fonoabsorbente. Fijación a pared mediante sistema magnético.

Panneau acoustique mural en feutrine de couleur de polyester thermoformé. Absorption du son ambient grâce à la forme du panneau acoustique, à l'espace intérieur vide et à sa matière insonorisante. Fixation au mur à l'aide d'un système magnétique.

VERSIONS, SIZES AND WEIGHT



BAM 01

15 x 10 x 60 cm
5,9 x 3,9 x 23,6 in.
0,7 kg
1,5 lb.

CUSTOMISE OPTIONS

 COLOUR

COLOURS

 AM · YELLOW

 NJ · ORANGE

 MR · BROWN

 AZ · BLUE

 VDC · LIGHT GREEN

 VD · GREEN

 FO · FOREST

 GR · GREY

 AN · ANTHRACITE

ENVIRONMENTAL IMPACT

Made from PET fibres. 100% recyclable.

Fabricado con fibras PET. 100% reciclable.

Fabriqu  avec fibres PET. 100% recyclable.

FIRE RESISTANCE

UNE-EN 13501-1
ASTM-E84

B-s1, d0
Clase A

WARRANTY

Two (2) year limited warranty. Does not cover: incorrect use, bad handling or deliberate damage.

Garant a de dos (2) a os limitada. No cubre: mal uso, manipulaci n o da os intencionados.

Garantie deux (2) ans. A l'exception: mauvaise utilisation, manipulation, dommages intentionn s.

PACKAGING

Cardboard box with plastic bag for product protection. One package.

Caja de cart n con bolsa de pl stico para protecci n. Un paquete.

Bo te en carton avec sac plastique pour la protection. Un paquet.

Bergamo

by La Mamba Studio

COMFORT

← VIEW PRODUCT PAGES

110

PHOTO



CHARACTERISTICS

Beech wood hanger, included in a sheet metal wall structure, attached using rawlplugs or as a coat stand. Wall structure made from 1.2mm sheet metal. Standing coat rack with 25mm square metal pole. Weighted base in stamped sheet metal. The post and base are unified using screws. Base supplied with rubber blocks to protect the surface where it is located.

Colgador de madera de haya torneada, situado en una estructura mural, en un perchero de pié o directo a pared mediante taco y tornillo de doble rosca. Estructura mural en chapa de hierro de 1,2 mm. Perchero de pié en tubo metálico cuadrado de 25 mm. Base en chapa de hierro estampada con peso en la parte inferior. Unión del tubo y base mediante tornillería. Base con tacos de goma para proteger la superficie donde se ubique.

Porte-manteau en bois de hêtre tourné, situé dans une structure murale, sur pied ou directement au mur à l'aide d'une cheville et d'une vis à double filetage. Structure murale en tôle de 1,2 mm. Portemanteau sur pied en tube métallique carré de 25 mm. Base en tôle emboutie avec poids dans la partie inférieure. Union du tube et de la base à l'aide de vis. Base avec des gommages de caoutchouc pour protéger la surface où il se trouve.

VERSIONS, SIZES AND WEIGHT

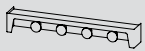

BRG 01

70 x 10 x 10 cm
4,6 x 3,9 x 3,9 in.
3,5 kg
7,7 lb.



BRG 10

Ø36 x 180 cm
Ø14,2 x 70,9 in.
7,5 kg
16,5 lb.



BRG M

Ø5,5 x 5,5 cm
Ø2,2 x 2,2 in.
0,3 kg
0,7 lb.
Only in wood

COLOURS

○ RAL 9003

● RAL 7016

● RAL 2004

● WOOD

CUSTOMISE OPTIONS

● COLOUR

② NUMBER OF HANGERS

ENVIRONMENTAL IMPACT

Materials may be easily disassembled to be recycled.

Materiales fácilmente separables para su posterior reciclado.

Matériaux facilement démontables pour leurs recyclages.

FIRE RESISTANCE

UNE-EN 13501-1

D-s2, d0

WARRANTY

Two (2) year limited warranty. Does not cover: incorrect use, bad handling or deliberate damage.

Garantía de dos (2) años limitada. No cubre: mal uso, manipulación o daños intencionados.

Garantie deux (2) ans. À l'exception: mauvaise utilisation, manipulation, dommages intentionnés.

PACKAGING

Cardboard boxes with plastic bags for product protection. One/two packages.

Cajas de cartón con bolsas de plástico para protección. Uno/dos paquetes.

Boîtes en carton avec sacs plastiques pour la protection. Un/deux paquets.

Bologna

by Eduard Juanola

COMFORT

← VIEW PRODUCT PAGES

134

PHOTO



CHARACTERISTICS

Coat and umbrella stand made Ø3mm metal or beechwood mast. Hangers made from Ø6mm chromed steel. Weighted base in stamped sheet metal. Unified post and base using screws and includes rubber blocks to protect the surface where it is located.

Perchero de pié y paraguero fabricados en tubo metálico o mástil de madera de haya de Ø30 mm. Colgadores en varilla de acero cromado de Ø6 mm encajadas al tubo. Base en chapa de hierro estampada con peso en la parte inferior. Unión del tubo y base mediante tornillería. Base con tacos de goma para proteger la superficie donde se ubique.

Porte-manteau et porte-parapluie en tube métallique ou mâst en bois de hêtre de Ø30 mm. Patères en tige d'acier chromé de Ø6 mm montés sur le tube. Base en tôle emboutie avec poids en partie inférieure. Union du tube et de la base à l'aide de vis. Base avec des gommés en caoutchouc pour protéger la surface où il se trouve.

VERSIONS, SIZES AND WEIGHT

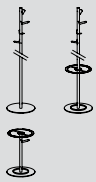

BOL 01 / 11

Ø36 x 180 cm
Ø14,2 x 70,9 in.
8 kg
17,6 lb.

BOL P

Ø36 x 50 cm
Ø14,2 x 19,7 in.

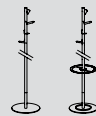

BOL 10 / 12

Ø36 x 180 cm
Ø14,2 x 70,9 in.
7 kg
15,4 lb.
Wood version

CUSTOMISE OPTIONS

- COLOUR
- NUMBER OF HANGERS

COLOURS

- RAL 9003
- RAL 7016
- WOOD + RAL 9003
- WOOD + RAL 7016
- RAL 2004

ENVIRONMENTAL IMPACT

Materials may be easily disassembled to be recycled.

Materiales fácilmente segregables para su posterior reciclado.

Matériaux facilement démontables pour leurs recyclages.

FIRE RESISTANCE

UNE-EN 13501-1

BOL 01 / 11
BOL 10 / 12
BOL P

A1-s1, d0
D-s2, d0
A1-s1, d0

WARRANTY

Two (2) year limited warranty. Does not cover: incorrect use, bad handling or deliberate damage.

Garantía de dos (2) años limitada. No cubre: mal uso, manipulación o daños intencionados.

Garantie deux (2) ans. À l'exception: mauvaise utilisation, manipulation, dommages intentionnés.

PACKAGING

Cardboard boxes with plastic bags for product protection. Two packages.

Cajas de cartón con bolsas de plástico para protección. Dos paquetes.

Boîtes en carton avec sacs plastiques pour la protection. Deux paquets.

Capri

by Jordi Blasi

COMFORT

← VIEW PRODUCT PAGES

122

PHOTO



CHARACTERISTICS

Coat and umbrella stand also wall mount made with Ø30mm iron tube. 5mm curved beechwood hanger. Weighted base in stamped sheet metal. Union of Post and base unified using screws. Base includes rubber blocks to protect the surface where it is located.

Perchero de pié, mural y paraguero fabricado en tubo de hierro de Ø30 mm. Colgador en lama de madera de haya curvada de 5 mm. Base en chapa de hierro estampada con peso en la parte inferior. Unión del tubo y base mediante tornillería. Base con tacos de goma para proteger la superficie donde se ubique.

Porte-manteau sur pied, mural et porte-parapluie fabriqué avec un tube de fer de Ø30 mm. Patère en bois de hêtre courbé de 5 mm d'épaisseur. Base en tôle emboutie avec un poids dans la partie inférieure. Union du tube et de la base à l'aide de vis. Base avec des gommages de caoutchouc pour protéger la surface où il se trouve.

VERSIONS, SIZES AND WEIGHT

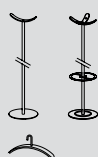

CPR 01 / 21
CPR 02 / 22
CPR 03 / 23

Ø36 x 170 cm
Ø14,2 x 66,9 in.
10 kg
22 lb.



CPR 12

Ø36 x 50 cm
Ø14,2 x 19,7 in.
5 kg
11 lb.



CPR 10

5 x 7,7 x 35 cm
2 x 3 x 13,8 in.
0,5 kg
1,1 lb.
Only in wood



CPR 20

5 x 5,7 x 25 cm
2 x 2,2 x 9,8 in.
0,5 kg
1,1 lb.
Only in wood

COLOURS

 RAL 9003 + WOOD

 RAL 9006 + WOOD

 RAL 2004 + WOOD

 RAL 7016 + WOOD

CUSTOMISE OPTIONS

 COLOUR

ENVIRONMENTAL IMPACT

Materials may be easily disassembled to be recycled.

Materiales fácilmente separables para su posterior reciclado.

Matériaux facilement démontables pour leurs recyclages.

FIRE RESISTANCE

UNE-EN 13501-1

D-s2, d0

WARRANTY

Two (2) year limited warranty. Does not cover: incorrect use, bad handling or deliberate damage.

Garantía de dos (2) años limitada. No cubre: mal uso, manipulación o daños intencionados.

Garantie deux (2) ans. À l'exception: mauvaise utilisation, manipulation, dommages intentionnés.

PACKAGING

Cardboard boxes with plastic bags for product protection. Two packages.

Cajas de cartón con bolsas de plástico para protección. Dos paquetes.

Boîtes en carton avec sacs plastiques pour la protection. Deux paquets.

Kyoto

by Joan Gaspar

COMFORT

← VIEW PRODUCT PAGES

176

PHOTO



CHARACTERISTICS

Polyethylene planter made with roto-moulding. Stainless steel post and base. Interior of planter holds water and functions as a water tank. Regulation of the water passage by means of a ceramic piece at the base. Tank cap in anodized aluminium. Base with rubber studs to protect the surface where it is located.

Jardinera de polietileno fabricada por roto-moldeo. Base y tubo de acero inoxidable. Interior de la jardinera vacío, que hace la función de depósito de agua. Regulación del paso de agua mediante una pieza cerámica en la base. Tapón del depósito en aluminio anodizado. Base con tacos de goma para proteger la superficie donde se ubique.

Jardinière en polyéthylène fabriquée par rotomoulage. Base et tube en acier inoxydable. Intérieur de la jardinière vide, qui sert de réservoir d'eau. Régulation du passage de l'eau au travers d'une pièce en céramique dans la base. Bouchon de réservoir en aluminium anodisé. Base avec des gommages de caoutchouc pour protéger la surface où elle se trouve.

VERSIONS, SIZES AND WEIGHT



KYT 01

Ø39,6 x 44 cm
Ø15,6 x 17,3 in.
5 kg
11 lb.



KYT 02

Ø39,6 x 57 cm
Ø15,6 x 22,4 in.
5,8 kg
12,8 lb.

COLOURS

○ BL · RAL 9003

● MO · RAL 1012

● TC · RAL 2001

● AN · RAL 7016

● NG · RAL 9011

ENVIRONMENTAL IMPACT

Materials may be easily disassembled to be recycled.

Materiales fácilmente segregables para su posterior reciclado.

Matériaux facilement démontables pour leurs recyclages.

FIRE RESISTANCE

UNE-EN 13501-1

B-s1, d1

WARRANTY

Two (2) year limited warranty. Does not cover: incorrect use, bad handling or deliberate damage.

Garantía de dos (2) años limitada. No cubre: mal uso, manipulación o daños intencionados.

Garantie deux (2) ans. À l'exception: mauvaise utilisation, manipulation, dommages intentionnés.

PACKAGING

Cardboard box with plastic bag for product protection. One package.

Caja de cartón con bolsa de plástico para protección. Un paquete.

Boîte en carton avec sac plastique pour la protection. Un paquet.

Menfis

by Mario Ruiz

COMFORT

← VIEW PRODUCT PAGES

212

PHOTO







CHARACTERISTICS

Signage system made using white lacquered extruded aluminium. The side caps are injected into zamak. Available in 4 height sizes and variable width as required. Covered using transparent plastic sheets that protect the signage. Suction cup is supplied for document extraction. Wall fixing using rawlplugs and screws or double-sided adhesive.

Sistema de señalización fabricado en aluminio extrusionado y lacado en blanco. Las tapas laterales están inyectadas en zamak. Disponible en 4 tamaños de altura y de anchura variable según necesidad. Lámina plástica transparente que protege el papel con la indicación. Se suministra ventosa para extracción del documento. Fijación a pared mediante taco y tornillo o adhesivo doble cara.

Système de signalétique en aluminium extrudé et laqué blanc. Les parties latérales sont injectés en zamak. Disponible en 4 hauteur différentes et de largeur variable selon les besoins. Feuille de plastique transparente qui protège le papier avec l'indication. Une ventouse est fournie pour l'extraction des documents. Fixation au mur à l'aide de cheville et vis ou d'un adhésif double face.

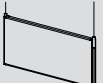
VERSIONS, SIZES AND WEIGHT

	WALL	MEN 01 MEN 02 MEN 03 MEN 04	H: 21 cm / 8,3 in H: 10,5 cm / 4,1 in H: 7 cm / 2,7 in H: 5,25 cm / 2,1 in		PROJECTED	MEN 11 MEN 12	H: 21 cm / 8,3 in H: 10,5 cm / 4,1 in
	HANGED	MEN 21	H: 21 cm / 8,3 in		DESK	MEN 31 MEN 32 MEN 33 MEN 34	H: 21 cm / 8,3 in H: 10,5 cm / 4,1 in H: 7 cm / 2,7 in H: 5,25 cm / 2,1 in
	STAND	MEN 41	H: 21 cm / 8,3 in				

Width: Please view page 217 for width options for each reference.

COLOURS

RAL 9003

CUSTOMISE OPTIONS

COLOUR

ENVIRONMENTAL IMPACT

Materials may be easily disassembled to be recycled.

Materiales fácilmente separables para su posterior reciclado.

Matériaux facilement démontables pour leurs recyclages.

FIRE RESISTANCE

UNE-EN 13501-1

A1-s1, d0

WARRANTY

Two (2) year limited warranty. Does not cover: incorrect use, bad handling or deliberate damage.

Garantía de dos (2) años limitada. No cubre: mal uso, manipulación o daños intencionados.

Garantie deux (2) ans. À l'exception: mauvaise utilisation, manipulation, dommages intentionnés.

PACKAGING

Cardboard box with plastic bag for product protection. One package.

Caja de cartón con bolsa de plástico para protección. Un paquete.

Boîte en carton avec sac plastique pour la protection. Un paquet.

Milano

by Roger Vancells

COMFORT

← VIEW PRODUCT PAGES

116

PHOTO



CHARACTERISTICS

Coat stand and wall rack. Available in 3 or 6 5mm curved beech slats, central unification made from 3mm sheet metal attached using non visible screws. Wood slats natural or lacquered. Wall version in 3mm iron sheet metal. Fixing to the wall using a rawlplug and screw.

Perchero de pie y mural. Disponible en 3 o 6 laminas de madera de haya curvada de 5 cm, unidas a una pieza central en chapa de hierro de 3 mm mediante tornillería no visible. Lamas de madera al natural o lacadas. Versión mural en chapa de hierro de 3 mn. Fijación a pared mediante taco y tornillo.

Porte-manteau sur pied et mural. Disponible en 3 ou 6 lattes de bois de hêtre courbé de 5 cm, reliées par une pièce centrale en tôle de 3 mm d'épaisseur par des vis non visibles. Lames en bois naturel ou laquées. Version murale en tôle de 3 mm d'épaisseur. Fixation au mur à l'aide de cheville et vis.

VERSIONS, SIZES AND WEIGHT

	MIL 03	Ø61 x 165 cm Ø24 x 65 in. 6 kg 13,2 lb.		MIL 06	Ø61 x 165 cm Ø24 x 65 in. 9 kg 19,8 lb.
	MIL 16	5 x 10 x 34,4 cm 2 x 3,9 x 13,5 in.			

Only available in metal

CUSTOMISE OPTIONS

COLOUR

COLOURS

- | | |
|----------|----------|
| RAL 9003 | RAL 7016 |
| RAL 2004 | WOOD |

ENVIRONMENTAL IMPACT

Materials may be easily disassembled to be recycled.

Materiales fácilmente segregables para su posterior reciclado.

Matériaux facilement démontables pour leurs recyclages.

FIRE RESISTANCE

UNE-EN 13501-1

MIL 03
MIL 06
MIL 16

D-s2, d0
D-s2, d0
A1-s1, d0

WARRANTY

Two (2) year limited warranty. Does not cover: incorrect use, bad handling or deliberate damage.

Garantía de dos (2) años limitada. No cubre: mal uso, manipulación o daños intencionados.

Garantie deux (2) ans. A l'exception: mauvaise utilisation, manipulation, dommages intentionnés.

PACKAGING

Cardboard boxes with plastic bags for product protection. One/two packages.

Cajas de cartón con bolsas de plástico para protección. Uno/dos paquetes.

Boîtes en carton avec sacs plastiques pour la protection. Un/deux paquets.

Nagoya

by Joan Gaspar

COMFORT

← VIEW PRODUCT PAGES

200

PHOTO



CHARACTERISTICS

Lectern made from an upholstered rotational polyethylene core. Metal base with 10mm sheet metal. Available fully wired up and including two power sockets, a microphone base and/or light. Incorporating cup holder and a bar to hold documents. Foot-rest bar in stainless steel. 2m electric cable.

Atril para conferencias fabricado mediante un núcleo de polietileno rotacional tapizado. Base metálica en chapa de hierro de 10 mm. Disponible versión electrificada que incluye un cajetín que contiene una regleta con dos tomas de corriente, una base para micrófono y/o luz. Incorpora reposa-vasos y barra sujeta documentos. Barra reposa-pies en acero inoxidable. Cable eléctrico de 2 m.

Pupitre de conférence fabriqué avec un noyau en polyéthylène tapissé. Base métallique en tôle de 10 mm d'épaisseur. Version électrifiée disponible comprenant un accès contenant deux prises, une base pour microphone et/ou lumière. Incorpore des reposes verres et une reglette pour maintenir les documents. Barre repose-pieds en acier inoxydable. 2m de câble électrique.

VERSIONS, SIZES AND WEIGHT



NAG 01

60 x 50 x 114 cm
23,6 x 19,7 x 44,9 in.
35 kg
77,2 lb.



NAG 02

60 x 50 x 114 cm
23,6 x 19,7 x 44,9 in.
35 kg
77,2 lb.

ACCESSORIES

NAG 15
NAG 20
NAG 30

Lamp
Microphone
A4 Sign

COLOURS

○ WHITE

● VIOLET

● ANTHRACITE

CUSTOMISE OPTIONS

● COLOUR

ENVIRONMENTAL IMPACT

Materials may be easily disassembled to be recycled.

Materiales fácilmente separables para su posterior reciclado.

Matériaux facilement démontables pour leurs recyclages.

FIRE RESISTANCE

UNE-EN 13501-1

B-s1, d1

WARRANTY

Two (2) year limited warranty. Does not cover: incorrect use, bad handling or deliberate damage.

Garantía de dos (2) años limitada. No cubre: mal uso, manipulación o daños intencionados.

Garantie deux (2) ans. À l'exception: mauvaise utilisation, manipulation, dommages intentionnés.

PACKAGING

Wooden box with plastic bag for product protection. One pallet.

Caja de madera con bolsa de plástico para protección. Un palé.

Boîte en bois avec sac plastique pour la protection. Une palette.

Napoli

by Eduard Juanola

COMFORT

← VIEW PRODUCT PAGES

152

PHOTO



CHARACTERISTICS

Coat and umbrella stand manufactured in Ø40mm sheet metal tubing. Injected plastic hangers. Weighted base in stamped sheet metal. Post and base unified using screws. Base includes rubber blocks to protect the surface where it is located.

Perchero de pié y paraguero fabricados en tubo metálico de Ø40 mm. Colgadores de plástico inyectado. Base en chapa de hierro estampada con peso en la parte inferior. Unión del tubo y base mediante tornillería. Base con tacos de goma para proteger la superficie donde se ubique.

Porte-manteau et porte-parapluie fabriqués en tube métallique de Ø40 mm. Patères en plastique injectés. Base en tôle emboutie avec poids dans la partie inférieure. Union du tube et de la base à l'aide de vis. Base avec des gommages de caoutchouc pour protéger la surface où il se trouve.

VERSIONS, SIZES AND WEIGHT

	NAP 01	Ø36 x 180 cm Ø14,2 x 70,9 in. 8 kg 17,6 lb.		NAP 10	Ø36 x 180 cm Ø14,2 x 70,9 in. 9 kg 19,8 lb.
	NAP P	Ø36 x 50 cm Ø14,2 x 19,7 in. 4 kg 8,8 lb.			

CUSTOMISE OPTIONS

COLOUR

COLOURS

RAL 9003 + 9003 RAL 9003 + 2004 RAL 9003 + 7016

ENVIRONMENTAL IMPACT

Materials may be easily disassembled to be recycled.

Materiales fácilmente segregables para su posterior reciclado.

Matériaux facilement démontables pour leurs recyclages.

FIRE RESISTANCE

UNE-EN 13501-1

B-s1, d1

WARRANTY

Two (2) year limited warranty. Does not cover: incorrect use, bad handling or deliberate damage.

Garantía de dos (2) años limitada. No cubre: mal uso, manipulación o daños intencionados.

Garantie deux (2) ans. A l'exception: mauvaise utilisation, manipulation, dommages intentionnés.

PACKAGING

Cardboard boxes with plastic bags for product protection. Two packages.

Cajas de cartón con bolsas de plástico para protección. Dos paquetes.

Boîtes en carton avec sacs plastiques pour la protection. Deux paquets.

Note-it

by Jordi Blasi + Nahrang

COMFORT

← VIEW PRODUCT PAGES

164

PHOTO



CHARACTERISTICS

Acoustic wall panel manufactured using 60% recycled polyester fiber. Absorbs the ambient sound thanks to its sound-absorbing properties and the irregular shape of the panels superimposed on the wall. Fixed to the wall using a Velcro® strip.

Panel acústico mural fabricado con un 60% de fibras de poliéster recicladas. Absorción del sonido ambiente gracias su propiedad fonoabsorbente y a la forma irregular de los paneles superpuestos en la pared. Fijación a pared mediante una tira de Velcro®.

Panneau acoustique mural composé à 60% de fibres de polyester recyclées. Absorption du son ambiant grâce à ses propriétés d'absorption acoustique et à la forme irrégulière des panneaux superposés au mur. Fixation au mur à l'aide d'une bande Velcro®.

VERSIONS, SIZES AND WEIGHT

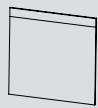

NOT 60

59 x 59 x 0,9 cm
23,2 x 23,2 x 0,35 in.
0,6 kg
1,3 lb.



NOT 30

29 x 29 x 0,9 cm
11,4 x 11,4 x 0,35 in.
0,2 kg
0,4 lb.

COLOURS

GR · GREY

AN · ANTHRACITE

NG · BLACK

AM · YELLOW

NJ · ORANGE

AZ · BLUE

VD · GREEN

CUSTOMISE OPTIONS

COLOUR

HEIGHT & WIDTH

ENVIRONMENTAL IMPACT

Made from 60% recycled PET fibres. 100% recyclable.

Fabricado con 60% de fibras PET recicladas. 100% reciclable.

Fabriqué avec 60% fibres PET recyclées. 100% recyclable.

FIRE RESISTANCE

UNE-EN 13501-1

A1-s1, d0

WARRANTY

Two (2) year limited warranty. Does not cover: incorrect use, bad handling or deliberate damage.

Garantía de dos (2) años limitada. No cubre: mal uso, manipulación o daños intencionados.

Garantie deux (2) ans. À l'exception: mauvaise utilisation, manipulation, dommages intentionnés.

PACKAGING

Cardboard box with plastic bag for product protection. One package.

Caja de cartón con bolsa de plástico para protección. Un paquete.

Boîte en carton avec sac plastique pour la protection. Un paquet.

PHOTO



CHARACTERISTICS

Mobile white board made from a plywood core topped with a high gloss sheet for writing with dry eraser pens. The bottom of the curved wood serves as a shelf for pens and accessories. Folding structure with wheels, in 16mm stainless steel. Includes paper pad holder.

Pizarra de pié fabricada en núcleo de contrachapado rematado con lámina de alto brillo para la escritura con rotuladores de borrado en seco. La parte inferior de la madera curva sirve de repisa para rotuladores y accesorios. Estructura plegable con ruedas, en tubo de acero inoxidable de Ø16 mm. Incluye soporte para bloc de papel.

Tableau composé d'un noyau de contreplaqué et d'une feuille laminée très brillante permettant d'écrire avec des marqueurs effaçables à sec. La partie inférieure du bois, courbée, sert d'auget pour les marqueurs et les accessoires. Structure pliante à roulettes, en tube d'acier inoxydable de Ø16 mm. Comprend un support pour bloc-notes.

VERSIONS, SIZES AND WEIGHT



OSK 01

81 x 60 x 180 cm
31,9 x 23,6 x 70,9 in.
10 kg
22 lb.

COLOURS

 WOOD + WHITEBOARD

ENVIRONMENTAL IMPACT

Materials may be easily disassembled to be recycled.

Materiales fácilmente segregables para su posterior reciclado.

Matériaux facilement démontables pour leurs recyclages.

FIRE RESISTANCE

UNE-EN 13501-1

D-s2, d0

WARRANTY

Two (2) year limited warranty. Does not cover: incorrect use, bad handling or deliberate damage.

Garantía de dos (2) años limitada. No cubre: mal uso, manipulación o daños intencionados.

Garantie deux (2) ans. À l'exception: mauvaise utilisation, manipulation, dommages intentionnés.

PACKAGING

Wooden box with plastic bag for product protection. One package.

Caja de madera con bolsa de plástico para protección. Un paquete.

Boîte en bois avec sac plastique pour la protection. Un paquet.

Padova

by Roger Vancells

COMFORT

← VIEW PRODUCT PAGES

140

PHOTO





CHARACTERISTICS

Coat and umbrella stand manufactured with Ø40mm metal tube. Injected plastic hangers inserted into post. Weighted base in stamped sheet metal. Post and base unified using screws. Includes rubber blocks to protect the surface where it is located.

Perchero de pié y paraguero fabricados en tubo metálico. Colgadores inyectados en plástico encajados en el tubo. Base en chapa de hierro estampada con peso en la parte inferior. Unión del tubo y base mediante tornillería. Base con tacos de goma para proteger la superficie donde se ubique.

Porte-manteau et porte-parapluie fabriqué en tube métallique de Ø40 mm. Patères en plastique injectés intégrés dans le tube. Base en tôle emboutie avec un poids dans la partie inférieure. Union du tube et de la base à l'aide de vis. Base avec des gommages de caoutchouc pour protéger la surface où il se trouve.



VERSIONS, SIZES AND WEIGHT

	PDV 01	Ø36 x 180 cm Ø14,2 x 70,9 in. 8 kg 17,6 lb.		PDV 10	Ø36 x 180 cm Ø14,2 x 70,9 in. 10 kg 22 lb.
	PDV P	Ø36 x 50 cm Ø14,2 x 19,7 in. 5 kg 11 lb.			

COLOURS

- RAL 9003
- RAL 9003 + 9006
- RAL 9003 + 2004
- RAL 9003 + 7016

CUSTOMISE OPTIONS

-  COLOUR
-  NUMBER OF HANGERS

ENVIRONMENTAL IMPACT

Materials may be easily disassembled to be recycled.

Materiales fácilmente segregables para su posterior reciclado.

Matériaux facilement démontables pour leurs recyclages.

FIRE RESISTANCE

UNE-EN 13501-1

B-s1, d1

WARRANTY

Two (2) year limited warranty. Does not cover: incorrect use, bad handling or deliberate damage.

Garantía de dos (2) años limitada. No cubre: mal uso, manipulación o daños intencionados.

Garantie deux (2) ans. À l'exception: mauvaise utilisation, manipulation, dommages intentionnés.

PACKAGING

Cardboard boxes with plastic bags for product protection. Two packages.

Cajas de cartón con bolsas de plástico para protección. Dos paquetes.

Boîtes en carton avec sacs plastiques pour la protection. Deux paquets.

Sapporo

by Toni Pallejà

COMFORT

← VIEW PRODUCT PAGES

182

PHOTO



CHARACTERISTICS

Auxiliary table made from 3 mm folded iron. With plastic stoppers on the legs to protect the surface where it is located.

Mesa auxiliar fabricada en chapa de hierro doblada de 3 mm. Con piezas de plástico en las patas para proteger la superficie donde se ubique.

Table auxiliaire fabriquée en tôle pliée de 3 mm d'épaisseur. Avec des pièces en plastique sous les pieds pour protéger la surface où elle se trouve.

VERSIONS, SIZES AND WEIGHT



SPR 01

58 x 43,3 x 28 cm
22,8 x 17 x 11 in.
10,5 kg
23,1 lb.

CUSTOMISE OPTIONS

 COLOUR

COLOURS

 RAL 9003

 RAL 1023

 RAL 2004

 RAL 3027

 RAL 5012

 RAL 6018

 RAL 7016

ENVIRONMENTAL IMPACT

Materials may be easily disassembled to be recycled.

Materiales fácilmente segregables para su posterior reciclado.

Matériaux facilement démontables pour leurs recyclages.

FIRE RESISTANCE

UNE-EN 13501-1

A1-s1, d0

WARRANTY

Two (2) year limited warranty. Does not cover: incorrect use, bad handling or deliberate damage.

Garantía de dos (2) años limitada. No cubre: mal uso, manipulación o daños intencionados.

Garantie deux (2) ans. A l'exception: mauvaise utilisation, manipulation, dommages intentionnés.

PACKAGING

Cardboard box with plastic bag for product protection. One package.

Caja de cartón con bolsa de plástico para protección. Un paquete.

Boîte en carton avec sac plastique pour la protection. Un paquet.

Siena

by Nahtrang

COMFORT

← VIEW PRODUCT PAGES

128

PHOTO



CHARACTERISTICS

Coatstand made up of of a 40mm beechwood mast, with 4 hangers in 3mm folded sheet metal. Weighted base in stamped sheet metal. Unified post and base using screws. Base includes rubber blocks to protect the surface where it is located.

Perchero de pié compuesto por un mástil de madera de haya de 40 mm, con 4 colgadores en chapa de hierro doblada de 3 mm. Base en chapa de hierro estampada con peso en la parte inferior. Unión del tubo y base mediante tornillería. Base con tacos de goma para proteger la superficie donde se ubique.

Porte-manteau sur pied composé d'un mât en hêtre de 40 mm et de 4 patères en tôle pliée de 3 mm d'épaisseur. Base en tôle emboutie avec poids dans la partie inférieure. Union du tube et de la base à l'aide de vis. Base avec des gommages de caoutchouc pour protéger la surface où il se trouve.

VERSIONS, SIZES AND WEIGHT





SIE 01

Ø36 x 180 cm
Ø14,2 x 70,9 in.
7 kg
15,4 lb.

STANDART TEXT
THE MOON
THE SUN
MERCURY
JUPITER

COLOURS

 WOOD + RAL 9003

 WOOD + RAL 2004

 WOOD + RAL 7016

CUSTOMISE OPTIONS

 COLOUR

 TEXT

ENVIRONMENTAL IMPACT

Materials may be easily disassembled to be recycled.

Materiales fácilmente segregables para su posterior reciclado.

Matériaux facilement démontables pour leurs recyclages.

FIRE RESISTANCE

UNE-EN 13501-1

D-s2, d0

WARRANTY

Two (2) year limited warranty. Does not cover: incorrect use, bad handling or deliberate damage.

Garantía de dos (2) años limitada. No cubre: mal uso, manipulación o daños intencionados.

Garantie deux (2) ans. À l'exception: mauvaise utilisation, manipulation, dommages intentionnés.

PACKAGING

Cardboard boxes with plastic bags for product protection. Two packages.

Cajas de cartón con bolsas de plástico para protección. Dos paquetes.

Boîtes en carton avec sacs plastiques pour la protection. Deux paquets.

Torino

by Eduard Juanola

COMFORT

← VIEW PRODUCT PAGES

146

PHOTO



CHARACTERISTICS

Coat and umbrella stand made using a Ø40 mm metal tube. Hinged hangers injected in plastic embedded in the post. Weighted base in stamped sheet metal. Post and base unified using screws. Base supplied with rubber blocks to protect the surface where it is located.

Percheros de pié y paraguero fabricados en tubo metálico de Ø40 mm. Colgadores batientes inyectados en plástico encajados en el tubo. Base en chapa de hierro estampada con peso en la parte inferior. Unión del tubo y base mediante tornillería. Base con tacos de goma para proteger la superficie donde se ubique.

Porte-manteau et porte-parapluie en tube métallique de Ø40 mm. Patères articulées en plastique injectés et encastrées dans le tube. Base en tôle emboutie avec poids dans la partie inférieure. Union du tube et de la base à l'aide de vis. Base avec des gommages de caoutchouc pour protéger la surface où il se trouve.

VERSIONS, SIZES AND WEIGHT

	TRN 05	Ø36 x 180 cm Ø14,2 x 70,9 in. 8 kg 17,6 lb.		TRN 15	Ø36 x 180 cm Ø14,2 x 70,9 in. 10 kg 22 lb.
	TRN P	Ø36 x 50 cm Ø14,2 x 19,7 in. 5 kg 11 lb.			

CUSTOMISE OPTIONS

- COLOUR
- NUMBER OF HANGERS

COLOURS

- RAL 9003 + 9003
- RAL 9003 + 7016
- RAL 9006 + 9003
- RAL 9006 + 7016
- RAL 9003 + 2004
- RAL 9006 + 2004

ENVIRONMENTAL IMPACT

Materials may be easily disassembled to be recycled. *Materiales fácilmente segregables para su posterior reciclado. Matériaux facilement démontables pour leurs recyclages.*

FIRE RESISTANCE

UNE-EN 13501-1 B-s1, d1

WARRANTY

Two (2) year limited warranty. Does not cover: incorrect use, bad handling or deliberate damage. *Garantía de dos (2) años limitada. No cubre: mal uso, manipulación o daños intencionados. Garantie deux (2) ans. À l'exception: mauvaise utilisation, manipulation, dommages intentionnés.*

PACKAGING

Cardboard boxes with plastic bags for product protection. Two packages. *Cajas de cartón con bolsas de plástico para protección. Dos paquetes. Boîtes en carton avec sacs plastiques pour la protection. Deux paquets.*

Treviso

by NutCreatives

COMFORT

← VIEW PRODUCT PAGES

104

PHOTO



CHARACTERISTICS

Wall hanger made from beech wood composed of 5 irregular pieces. Also in combination of lacquered pieces and wood. Fixed to the wall using a screw and a double screw.

Perchero mural de madera de haya compuesto por 5 piezas irregulares. También en combinación de piezas lacadas y madera. Fijación a pared mediante taco y tornillo de doble rosca.

Porte-manteau mural en bois de hêtre composé de 5 pièces irrégulières. Également disponible en combinaison de pièces laquées et de bois brut. Fixation au mur à l'aide d'une cheville et d'une vis à double filetage.

VERSIONS, SIZES AND WEIGHT



TRE 01

11 x 11 x 6 cm
4,3 x 4,3 x 2,4 in.
0,4 kg
0,9 lb.
Wood and colours version



TRE 02

11 x 11 x 6 cm
4,3 x 4,3 x 2,4 in.
0,4 kg
0,9 lb.
Wood version

COLOURS

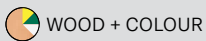

WOOD + COLOUR



WOOD

CUSTOMISE OPTIONS



COLOUR

ENVIRONMENTAL IMPACT

Materials may be easily disassembled to be recycled.

Materiales fácilmente segregables para su posterior reciclado.

Matériaux facilement démontables pour leurs recyclages.

FIRE RESISTANCE

UNE-EN 13501-1

D-s2, d0

WARRANTY

Two (2) year limited warranty. Does not cover: incorrect use, bad handling or deliberate damage.

Garantía de dos (2) años limitada. No cubre: mal uso, manipulación o daños intencionados.

Garantie deux (2) ans. À l'exception: mauvaise utilisation, manipulation, dommages intentionnés.

PACKAGING

Custom cardboard box for product protection. One package.

Caja de cartón personalizada para protección. Un paquete.

Boîte en carton personnalisée pour la protection. Un paquet.

PHOTO



CHARACTERISTICS

Acoustic wall panel made of thermoformed polyester colourfelt felt. Absorbs ambient noise thanks to the shape of the acoustic panel, the interior and the hollow interior and phonoabsorbent material. Wall-mounted via magnetic system.

Panel acústico mural fabricado en fieltro de colores de poliéster termoconformado. Absorción del sonido ambiente gracias a la forma del panel acústico, el espacio vacío interior y el material fonoabsorbente. Fijación a pared mediante sistema magnético.

Panneau acoustique mural en feutrine de couleur de polyester thermoformé. Absorption du son ambiant grâce à la forme du panneau acoustique, à l'espace intérieur vide et à sa matière insonorisante. Fixation au mur à l'aide d'un système magnétique.

VERSIONS, SIZES AND WEIGHT

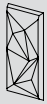

VVY 10

44 x 84 x 7 cm
17,3 x 33,1 x 2,8 in
0,7 kg
1,5 lb.

CUSTOMISE OPTIONS

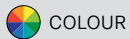



COLOUR

COLOURS

 AM · YELLOW

 NJ · ORANGE

 MR · BROWN

 AZ · BLUE

 VDC · LIGHT GREEN

 VD · GREEN

 FO · FOREST

 GR · GREY

 AN · ANTHRACITE

ENVIRONMENTAL IMPACT

Made from PET fibres. 100% recyclable.

Fabricado con fibras PET. 100% reciclable.

Fabriquée avec fibres PET. 100% recyclable.

FIRE RESISTANCE

UNE-EN 13501-1
ASTM-E84

B-s1, d0
Clase A

WARRANTY

Two (2) year limited warranty. Does not cover: incorrect use, bad handling or deliberate damage.

Garantía de dos (2) años limitada. No cubre: mal uso, manipulación o daños intencionados.

Garantie deux (2) ans. À l'exception: mauvaise utilisation, manipulation, dommages intentionnés.

PACKAGING

Cardboard boxes with plastic bags for product protection. Two packages.

Cajas de cartón con bolsas de plástico para protección. Dos paquetes.

Boîtes en carton avec sacs plastiques pour la protection. Deux paquets.

Colour & finishes

MATERIALS

 WOOD · BER, BOL, CPR, MIL, TRE

 WOOD · SIE

 WOOD · NYO

 INOX

 OXI

FABRICS

 AM · YELLOW

 AZ · BLUE

 FO · FOREST

 NJ · ORANGE

 VDC · LIGHT GREEN

 GR · GREY

 MR · BROWN

 VD · GREEN

 AN · ANTHRACITE

INJECTION

 BL · RAL 9003

 TC · RAL 2001

 GR · RAL 9006

 MO · RAL 1012

 AZ · RAL 5012

 NG · RAL 9011

 NJ · RAL 2004

 AN · RAL 7016

LACQUERED

 BL · RAL 9003

 AZ · RAL 5012

 MR · RAL 8016

 AM · RAL 1023

 VD · RAL 6016

 GR · RAL 9006

 NJ · RAL 2004

 VD · RAL 6018

 NG · RAL 9011

 RJ · RAL 3027

 AN · RAL 7016

PLASTIC

 BL · PLAKENE · P000

 VD · PLAKENE · P208

 AM · PLAKENE · P706

 AZ · PLAKENE · P100

 NJ · PLAKENE · P440

VINYL

 BLUE

 YELLOW

 BROWN

 GREEN

 GREY

 RED

Credits

Special thanks to our team

Alain Rodrigo, Ana Aparicio, Bertrand Lauvernier, Carmen Rodríguez, David Morales, Diego Morales, Enrique Almanchel, Eva Ríos, Francesc Salinas, Javier Hernández, Javier López, Joan Bruguera, Joaquín Serrano, Joaquín Nebot, Joaquín Vidal, José Antonio Ponte, José Luis Bootello, Juan Bernabeu, Juan de la Cruz Sánchez, Juan Martínez, Ligia Goyes, Lina Mazeneth, M^a Carmen Borrás, María Roset, Michael Tyrrell, Montse Paloma Alcalde, Oscar de Manuel, Pol Cunillera, Quim López, Rafael Díaz, Sonia Gil and Toni Latorre.

Interns: Albert Duarte, Daniel Martínez and Pol Villegas.

Concept and creative direction

Sr. y Sra. Wilson

Photography

Befree Studio

Floral Stylist

Flosh Atelier

Printing

Impuls 45

Papers

BioTop by Mondi

Pop'Set Black by ArjoWiggins

We are grateful for the collaboration of

Akaba ^{54, 65, 66, 79, 81, 85, 91, 111, 112, 136, 142, 166, 167, 213, 214}

Belone ^{172, 173, 207, 209}

Estiluz ^{15, 16, 17, 22, 29, 35, 36, 48, 49, 53, 59, 61, 71, 72, 73, 81, 86, 87, 91, 92, 93, 97, 98, 99, 105, 107, 131, 136, 147, 148, 149, 160, 171, 172, 173, 177, 178, 183, 184, 185, 203, 207, 208, 209}

Grassoler ^{36, 47, 59, 60, 80, 92, 93, 113, 125, 130, 148, 149, 161, 177, 178, 184, 185, 215}

JG Group ^{54, 65, 66, 79, 81, 85, 91, 111, 112, 124, 136, 142, 165, 166, 167, 213, 214}

Joquer ^{97, 118, 119, 130, 131, 196}

Marset ^{21, 43, 47, 54, 65, 66, 79, 81, 85, 91, 111, 112, 113, 117, 118, 123, 124, 125, 131, 136, 142, 153, 154, 165, 184, 185, 191}

Nanimarquina ^{36, 42, 47, 113, 118, 119, 125, 130, 131, 159, 160, 161, 177, 178, 183, 189, 190, 191, 196}

Now Carpets ^{184, 185}

Ölend ^{105, 106, 118, 121, 123, 136, 142, 149}

Santa&Cole ^{189, 190}

Teixidors ^{119, 196}

Vibia ^{31, 41, 66, 85, 105, 106, 119, 120, 142}

Vitra ^{16, 42, 80, 85, 106, 189, 190, 191, 192, 195, 196, 197, 198, 199}

Special attrezzo

Fashion accessories: Aeronautica Militare, Coomo, Daniele Fiesoli, Shasèl, Sunstripes

Desk accessories: Lamy, Leuchtturm1917, Remember, Semikolon

Books: Lunweg Editores / Planeta de libros

made design

Headquarters

Polígono Industrial Pla d'en Coll
Camí de la Font Freda 17, Nave 4
08110 Montcada i Reixac
Barcelona, Spain

T. +34 935 616 595
F. +34 935 616 597

info@made.design.es
www.madedesign.es

follow us
@made_design

is part of

Planning
Sisplamo