

# Best of

## Retail Systems





# Contents

<b>HIGHLIGHTS_MADE BY WANZL</b> .....	<b>5</b>	Checkout barriers .....	
<b>OVERVIEW</b> .....	<b>6-7</b>	<sup>04</sup> Swivel Doors · RP/RPS Checkout Barrier · .....	
		S Checkout Barrier, self-locking .....	58
		Partition Systems .....	
		<sup>05</sup> Classic Customer Guidance System .....	60
		<sup>06</sup> Railix Partitions .....	62
		Bumper Systems .....	
		<sup>07</sup> Guide Rails: TechnoLine · NX Stainless Steel · .....	
		Protec 3® Bumper System · Bumper Bars ...	64
<b>01 TROLLEY SYSTEMS</b> .....	<b>8</b>	<b>03 PRESENTATION</b> .....	<b>66</b>
Shopping trolleys .....		Bargain Tables .....	
<sup>01</sup> EL Series .....	10	<sup>01</sup> Table 8 · Design 99 .....	68
<sup>02</sup> ELX Series .....	12	<sup>02</sup> P and PS Bargain Tables .....	70
<sup>03</sup> DRC Series .....	14	Special Offer Baskets .....	
<sup>04</sup> Tango® Series .....	16	<sup>03</sup> Bargain Baskets · GVK Sales Baskets .....	72
<sup>05</sup> City-Shopper 2 .....	18	<sup>04</sup> Joker Display · Basket Presentation .....	
<sup>06</sup> Tangolino · DR22 .....	20	Stands .....	74
<sup>07</sup> FunMobil 80 + FunMobil Compact 140 .....	22	Sales Unit for Fruit, Vegetables and Flowers .....	
<sup>08</sup> Trend Baby Seat .....	24	<sup>05</sup> Vario Flower Display .....	76
<sup>09</sup> Rack for Infant Car Seat .....	25	<sup>06</sup> Mobilo .....	77
<sup>10</sup> MUC® Series .....	26	<sup>07</sup> Swing Sloping Display .....	78
<sup>11</sup> SP Special Transporter .....	28	<sup>08</sup> Cube® .....	80
<sup>12</sup> Furniture Trolleys .....	30	<sup>09</sup> Twinn® .....	82
<sup>13</sup> Scandy S .....	32	<sup>10</sup> Universal .....	84
<sup>14</sup> GC 100-3 Shopping Trolley .....	33	Special Offer Displays .....	
<sup>15</sup> Gardener 100 .....	34	<sup>11</sup> AD 100 Joy · AD 200 · AD 300 .....	86
<sup>16</sup> Planter D + P .....	35	Sales Systems for Pallets .....	
<sup>17</sup> Shopping Trolley Accessories .....	36	<sup>12</sup> Possibility .....	88
<sup>18</sup> Coin deposit systems .....	38	<sup>13</sup> Paletti .....	90
Shopping Baskets and Systems .....		<sup>14</sup> POSmodul 7/7 (Module 2) .....	92
<sup>19</sup> Shopping Baskets .....	40	<sup>15</sup> Pallet Boxes .....	94
<sup>20</sup> Take 2 and Shop & Roll .....	42	Shelf Baskets .....	
Row Docking Stations and Trolley Shelters .....		<sup>16</sup> KMF Stacking Baskets .....	96
<sup>21</sup> In-Store and Outdoor .....		<sup>17</sup> KKF Stacking Baskets .....	98
Row Docking Stations .....	44	<sup>18</sup> Shelf Baskets · Insert Baskets .....	100
<sup>22</sup> Economy and Delta 2 Trolley Shelters .....	46	<sup>19</sup> L and S Series Hang-In Basket .....	
<sup>23</sup> Sigma Trolley Shelter .....	48	Systems .....	102
<b>02 ACCESS SYSTEMS</b> .....	<b>50</b>	<b>04 SECTOR-SPECIFIC SOLUTIONS</b> .....	<b>104</b>
Entry Systems .....		<sup>01</sup> Garden Centres .....	104
<sup>01</sup> eGate® .....	52	<sup>02</sup> Beverage Retailers .....	106
<sup>02</sup> Technoport® .....	54	<sup>03</sup> Health Food Stores .....	108
<sup>03</sup> Ecoport .....	56	<sup>04</sup> Furniture Centres .....	110



# Best Sellers for Direct Customers

## Highlights\_Made By Wanzl



In-house castor production



In-house CAD development

### *Production*

■ **Wanzl sets the standards for production:** In all production processes, Wanzl's quality policy results in products made with the best materials, first-class workmanship and well-finished surfaces. This ensures long-term maintenance-free use and investment security.

### *Quality*

■ **Wanzl sets the standards for quality:** particularly regarding smooth movement: the castors are mounted on two maintenance-free ball bearings and have abrasion-proof treads. As a result, our shopping trolleys are quiet, smooth-running and easy to steer.

### *Innovation*

■ **Wanzl sets the standards for innovation:** from practical experience – for practical use: Using cutting-edge production and design technology, we create innovative, forward-looking products and constantly set new standards for handling and effectiveness. In this way we streamline your business guaranteeing that you have the best possible facilities, long into the future.



Trolley Systems

Access Systems

Presentation

Sector-Specific Solutions



# 01 Product overview

## 01.01 – 01.05 Shopping Trolley Series



01 EL SERIES      02 ELX SERIES      03 DRC SERIES      04 TANGO SERIES      05 CITY-SHOPPER 2

## 01.06 – 01.07 Children's Shopping Trolleys



06 TANGOLINO + DR22      07 FUNMOBIL 80 + FUNMOBIL COMPACT 140

## 01.08 – 01.09 Baby Seats and Seat Racks



08 COMFORT BABY SEAT      09 RACK FOR INFANT CAR SEAT

## 01.10 – 01.16 Sector-Specific Shopping Trolleys and Transport Trolleys



10 MUC SERIES    11 SP SPECIAL TRANSPORTER    12 FURNITURE TROLLEYS    13 SCANDY S    14 GC 100-3    15 GARDENER 100    16 PLANTER D + P

## 01.17 – 01.20 Accessories, Coin deposit systems, Shopping Baskets, Shopping Systems



17 ACCESSORIES: HANDLE AND COIN DEPOSIT SYSTEMS    18 COIN DEPOSIT SYSTEMS    19 SHOPPING BASKETS    20 TAKE 2    20 SHOP & ROLL

## 01.21 – 01.23 Row Docking Stations, Trolley Shelters

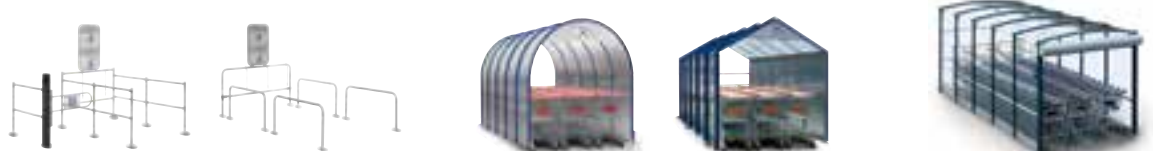

21 IN-STORE RDS + OUTDOOR RDS    22 ECONOMY + DELTA 2 TROLLEY SHELTERS    23 SIGMA TROLLEY SHELTER



# 01 Trolley Systems



# 01.01 EL Series

*The shopping trolley series designed to reduce inventory losses*

- > Less engineering – more profits*
- > Items can only be carried in the basket*
- > Available in 5 different basket sizes – child safety seat as standard*



EL75

# 01.01 EL Series

■ **Other than inside the basket**, the EL shopping trolley is specially designed not to allow carriage of items anywhere else. This feature was specifically requested by our partners in retail and is aimed at reducing losses of inventory.

## Easily viewable at the checkout counter

### At a glance:

Checkout staff can concentrate thoroughly on the contents of the basket. A well-arranged open chassis of oval tubing also provides extra leg room and saves space when trolleys are nested.



## Attractive colours optional

**Five selected standard colours** for handle caps and child safety seats.

**Finish:** coloured, plastic powder-coated.

**Advertising insert on handle:** screen-printed with non-fading inks.



Flame red	RAL 3000	
Pure orange	RAL 2004	
Traffic green	RAL 6024	
Ultramarine blue	RAL 5002	
Anthracite grey	RAL 7016	

**Standard equipment:** Robust chassis of flat oval tubing. Tightly meshed basket. Easy-grip round tubular handle, plastic end caps and deflector rings in Anthracite grey RAL 7016.

**Finish:** High-gloss galvanised and chrome-plated with baked-on plastic paint protection.

**Castors:** Original Wanzl swivel castors, rubber tread.

	EL75	EL90	EL101	EL130	EL150
<b>Order no.</b> (high-gloss, galvanised, chrome-plated + painted)	02.29 983.51	02.29 987.51	02.29 745.51	02.29 991.51	02.29 747.51
A x B x C, length x width x height (mm)	820 x 555 x 965	825 x 555 x 1015	955 x 595 x 975	1045 x 595 x 1020	1025 x 595 x 975
Basket volume (litres)	74	86	101	133	156
Castor Ø (mm)	100	100	125	125	125
Weight (kg)	14.0	15.0	18.5	20,0	20.5
Loading capacity (kg)	74	86	101	133	156
Nesting depth per trolley (mm)	150	150	202	187	187
Space required for 10 trolleys (mm)	2,170	2,175	2,780	2,715	2,695
Space required for 50 trolleys (mm)	8,170	8,175	10,860	10,195	10,175
Capacity of 3-row trolley shelter, length 5 m	84 copies	84 copies	60 copies	66 copies	66 copies
<b>Accessories</b>					
Wanzl-Box Classic coin deposit system, €1 / 50 cent	☑	☑	☑	☑	☑

For more accessories, see pages 36-37

# 01.02 ELX Series

*The shopping trolley series with flexible extra loading space*

- > *Versatile use of the tray for PET packs and drinks crates*
- > *Increased revenue thanks to greater storage space*
- > *Separation of delicate and heavy goods*



**ELX 185**  
with fold-out tray

Pat. pend.

# 01.02 ELX Series

■ **Holds everything, carries everything.** The ELX series has been developed in close cooperation with our business partners.

### Intelligent mechanism

**Extended trays** are automatically swivelled back when the shopping trolleys are nested.



### More space, increased turnover

The combination of basket and external tray at the back offers even more space: it can hold up to 4 PET six-packs = 24 x 1.5 litre bottles.



ELX 185

ELX 185

### Versatile use

Whether PET packs, drinks crates or washing powder boxes of different sizes, the tray of the ELX shopping trolley transports heavy and bulky items with ease.

**Standard equipment:** Robust chassis of flat oval tubing with fold-out crate holder. Tightly meshed basket. Easy-grip round tubular handle, plastic end caps and deflector rings in Anthracite grey RAL 7016.

**Finish:** High-gloss galvanised and chrome-plated with baked-on plastic paint protection.

**Castors:** Original Wanzl swivel castors, rubber tread.



	ELX 90	ELX 101	ELX 130	ELX 185
<b>Order no.</b> (high-gloss, galvanised, chrome-plated + painted)	02.52 550.51	02.53789.51	02.19250.51	02.49269.51
A x B x C, length x width x height (mm)	805 x 555 x 987	905 x 600 x 980	985 x 595 x 1025	1065 x 600 x 1060
Basket volume (litres)	86	101	130	178
Castor Ø (mm)	125	125	125	125
Weight (kg)	19.3	22.0	23.0	24.0
Loading capacity (kg)	106	121	150	198
Nesting depth per trolley (mm)	175	202	187	202
Space required for 10 trolleys (mm)	2,380	2,725	2,670	2,885
Space required for 50 trolleys (mm)	9,380	10,805	10,150	10,965
Capacity of 3-row trolley shelter, length 5 m	69 copies	60 copies	63 copies	60 copies
<b>Accessories</b>				
Wanzl-Box Classic coin deposit system, €1 / 50 cent	☐	☐	☐	☐

For more accessories, see pages 36-37

## 01.03 DRC Series

*The compact shopping trolley series with loads of space*

- › *Pleasant, convenient shopping experience*
- › *Large bottom tray as standard – for increased revenue*
- › *Available in a variety of basket sizes*



D 75 RC

Pat. pend.

# 01.03 DRC Series

■ **An extreme space-saver** – the compact DRC series features lots of storage space.

## Convenient

With lots of space between the bottom tray and the bottom of the basket, the D75RC has room for one drinks crate, while the D80RC and larger models can hold two crates of 1.5-litre bottles.



## Attractive colours optional

Five selected standard colours for handle caps and child safety seats.

**Finish:** coloured, plastic powder-coated.

**Advertising insert on handle:** screen-printed with non-fading inks.



Flame red	RAL 3000	
Pure orange	RAL 2004	
Traffic green	RAL 6024	
Ultramarine blue	RAL 5002	
Anthracite grey	RAL 7016	

**Standard equipment:** Robust chassis with steel wire bottom tray. Tightly meshed basket. Easy-grip round tubular handle, plastic end caps and deflector rings in Anthracite grey RAL 7016.

**Finish:** High-gloss galvanised and chrome-plated with baked-on plastic paint protection.

**Castors:** Original Wanzl swivel castors, rubber tread.

	D 75 RC	D 80 RC	D101RC	D155RC	D185RC
<b>Order no.</b> (high-gloss, galvanised, chrome-plated + painted)	02.06 921.51	02.43 619.51	02.06 951.51	02.52 385.51	02.52 386.51
A x B x C, length x width x height (mm)	795 x 515 x 1025	968 x 577 x 1003	900 x 570 x 1075	1041 x 600 x 1036	1055 x 600 x 1105
Basket volume (litres)	74	80	100	143	179
Castor Ø (mm)	100	125	125	125	125
Weight (kg)	16,5	20,0	22,0	30,0	31,0
Loading capacity (kg)	124	130	150	193	229
Nesting depth per trolley (mm)	120	205	202	235	235
Space required for 10 trolleys (mm)	1.875	2.813	2,720	3,155	3,170
Space required for 50 trolleys (mm)	6.675	11.013	10,800	12,555	12,570
Capacity of 3-row trolley shelter, length 5 m	108 units	90 copies	63 copies	51 copies	51 copies
<b>Accessories</b>					
Wanzl-Box Classic coin deposit system, €1 / 50 cent	☑	☑	☑	☑	☑

For more accessories, see pages 36-37

# 01.04 Tango® Series

*Attractive shopping trolley series with honeycomb structure for the basket*

- > *Light, yet sturdy and safe*
- > *Extra noise reduction – quiet like no other*
- > *Available in different basket sizes and a broad range of colours*



TANGO® 160P

Pat. pend.



# 01.04 Tango® Series

■ **Pure shopping pleasure** – the Tango® makes shopping an even more convenient and pleasant experience. Its innovative design makes this shopping trolley very light, yet extremely sturdy and stable.

*The small assistant that's a big help – the Tango® City*



**Ideal for small shopping trips**

Tango® City is the trendy shopping trolley for small and medium-sized stores.

### Three chassis variants

available in anti-theft design (E) or traditional shape (P) enabling precise tailoring to the product range. One-piece chassis constructions made from flat oval tubing. Additional equipment options such as tray, folding tray and bottom tray (RC) available depending on the model.



**TANGO® 90 E / EA**  
tray for PET packs and drinks crates optional.



**TANGO® 160 E**  
no tray options.



**TANGO® 160 P**  
available with crate holder or bottom tray.

### Attractive colours optional

**Selected standard colours\*** enable lots of colour configurations.

**Advertising insert on handle:** screen-printed with non-fading inks.

Basket		Promobox plus · Handle caps · Folding child seat · Deflector profile · Divider* · Small item tray* · Bag hook, back/front* · Scanner holder* · Cup holder* · Flower holder*	
Flame red	RAL 3000	Flame red	RAL 3000
Ultramarine blue	RAL 5002	Ultramarine blue	RAL 5002
Slate grey	RAL 7015	Slate grey	RAL 7015

\* Custom colours available on request / Standard colours for Tango City available on request

**Standard equipment:** Robust chassis of flat oval tubing. Tightly meshed basket with a sophisticated honeycomb design, constructed in food-safe plastic. Promobox plus coin deposit system, plastic handle caps in Slate grey RAL 7015. Plastic deflector rings in Anthracite

grey RAL 7016.

**Finish:** High-gloss galvanised and chrome-plated with baked-on plastic paint protection.

**Castors:** Original Wanzl swivel castors, rubber tread.

	Tango® City	Tango® 90E	Tango® 160E	Tango® 160P	Tango® 220P	Tango® 240P
<b>Order no.</b> (high-gloss, galvanised, chrome-plated + painted):	02.54 015.95	02.17 700.95	02.24 296.95	02.17 628.95	02.19 211.95	02.58 090.95
A x B x C, length x width x height (mm)	922 x 530 x 1007	995 x 595 x 1010	1060 x 595 x 1050	1060 x 595 x 1050	1140 x 595 x 1093	1266 x 595 x 1080
Basket volume (litres)	77	90	160	160	220	240
Castor Ø (mm)	125	125	125	125	125	125
Weight (kg)	13	16.8	18.5	19.0	21.5	22
Loading capacity (kg)	77	90	160	180	240	260
Nesting depth per trolley (mm)	220	240	280	280	295	295
Space required for 10 trolleys (mm)	2,902	3,155	3,580	3,620	3,795	3,921
Space required for 50 trolleys (mm)	11,702	12,755	14,780	14,820	15,595	15,721
Capacity of 3-row trolley shelter, length 5 m	57 copies	51 copies	45 copies	45 copies	42 copies	39 copies
<b>Accessories</b>						
Promobox plus coin deposit system, €1 / 50 cent	☑	☑	☑	☑	☑	☑

# 01.05 City-Shopper 2

*Elegant shopping trolley for exclusive product ranges*

- > *Ideal for indoor use in sophisticated speciality stores such as*
- > *delicatessens, boutiques, fragrance stores, chemists or shopping centres*
- > *Basket volumes of 40 or 60 litres*



**CITY-SHOPPER CS 40**  
Standard without child safety seat

**CITY-SHOPPER CS 60\***  
Standard with child safety seat, bottom tray optional

# 01.05 City-Shopper 2

■ **Even with its compact design**, the City-Shopper 2 offers a lot of space for purchases, especially when equipped with the large, optional bottom tray. This tray will accommodate drinks crates and bulky items.

## Child safety seat with safety belt

**Standard in the CS 60:** Safe and pleasant shopping with child on board.

CS 40 is only available without child safety seat.



## Bottom tray optional

The large mesh size of the bottom tray deters theft of small items.



## Saving space in the smallest places

**Not one centimetre is wasted** when the trolleys are nested.



**Standard equipment:** Chassis of round tubing, tightly meshed basket with rounded corners. Easy-grip round tubular handle, plastic end caps and deflector rings in Anthracite grey RAL 7016.

**Finish:** High-gloss chrome-plated with baked-on plastic paint protection.

**Castors:** Original Wanzl swivel castors, rubber tread.

\* Bottom tray on request

	CS40*	CS60
<b>Order no.</b> (high-gloss chrome-plated + painted)	02.30 284.11	02.30 285.11
A x B x C, length x width x height (mm)	743 x 524 x 980	765 x 524 x 980
Basket volume (litres)	40	60
Castor Ø (mm)	100	100
Weight (kg)	14.5	15.5
Loading capacity (kg) / with bottom tray	40 / 90	60 / 110
Nesting depth per trolley (mm)	170	170
Space required for 10 trolleys (mm)	2,275	2,295
Space required for 50 trolleys (mm)	9,085	9,095
<b>Accessories</b>		
Wanzl-Box Solid coin deposit system, €1	01.94 040.01	01.94 040.01

Illustrations show optional equipment (bottom tray)

# 01.06 Tangolino and DR22

*Shop like a "grown-up"*

- > A child-friendly revenue driver
- > Just the thing for little helpers constantly on the go
- > Plastic parts available in standard colours



**TANGOLINO**  
Children's shopping trolleys    Design pend.

**DR22**  
Children's shopping trolleys    Pat. pend.

# 01.06 Tangolino and DR22

■ **Good-looking** and child's play to move around – that's the Tangolino and the DR22. They provide a more relaxed shopping experience, as parents are happy when the children are kept busy.

## Tangolino: Attractive colours optional

**Selected standard colours** for basket and handle caps.  
**Finish:** coloured, plastic powder-coated.  
**Advertising insert on handle:** screen-printed with non-fading inks.

## Basket and flap, colour combinations available

Melon yellow	RAL 1028	
Flame red	RAL 3000	
Ultramarine blue	RAL 5002	

Special colours on request

**Tangolino standard equipment:** Robust chassis of oval tubing. Tightly meshed basket and end caps made of plastic. Plastic deflector rings, Anthracite grey RAL 7016.  
**Chassis finish:** High-gloss galvanised and chrome-plated with baked-on plastic paint protection.  
**Castors:** castors mounted on ball bearings, rubber treads.

## Flag, printed on both sides.

**On request** we will design the flag according to your template. Usable space is about 100 x 170 mm.







## Flagpole with integrated pushing handle

**Accompanying persons can help** when the driving skills of the little ones aren't quite sufficient. They also act as efficient theft deterrents.

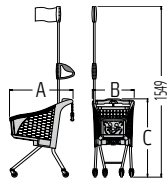

**DR22 standard equipment:** Robust chassis and a tightly meshed steel wire basket. Plastic handle end caps.  
**Finish:** High-gloss galvanised and chrome-plated with baked-on plastic paint protection.  
**Castors:** castors mounted on ball bearings, rubber treads.

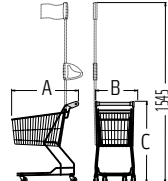
Tangolino	
	
<b>Order no.</b> (high-gloss, galvanised, chrome-plated + painted)	02.39 551.95
A x B x C, length x width x height (mm)	572 x 380 x 711
Basket volume (litres)	25
Castor Ø (mm)	50
Weight (kg)	5.7
Loading capacity (kg)	25
Space required per trolley (mm)	190
Space required for 10 trolleys (mm)	2,280
<b>Accessories</b>	<b>Order no.</b>
Wanzl-Promobox plus coin deposit system, €1 / 50 cent	01.61 065.00
Flagpole with integrated pushing handle, neutral flag	01.66 787.11

DR22	
	
<b>Order no.</b> (high-gloss, galvanised, chrome-plated + painted)	02.03 908.51
A x B x C, length x width x height (mm)	550 x 385 x 700
Basket volume (litres)	22
Castor Ø (mm)	50
Weight (kg)	4.8
Loading capacity (kg)	22
Space required per trolley (mm)	130
Space required for 10 trolleys (mm)	1,720
<b>Accessories</b>	<b>Order no.</b>
Wanzl-Classic coin deposit system, €1	01.75 010.01
Flagpole with integrated pushing handle, neutral flag	01.41 792.11

# 01.07 FunMobil 80 and FunMobil Compact 140

*Driving and shopping pleasure for all ages*

- > *Attractive, robust plastic chassis*
- > *A family-friendly option that delivers higher revenue*
- > *Fun element for greater customer loyalty*



**FUNMOBIL 80**  
with room for 2 children

Design pend.

**FUNMOBIL COMPACT 140**  
with room for 1 child

Design pend.

# 01.07 FunMobil 80 and FunMobil Compact 140

■ **Both FunMobil models** provide a fun experience for small shoppers on tour with the grown-ups. This family-friendly offering will secure existing customers and attract new ones whose children want to go "where the cars are".

## Integrated safety belt



**Standard in both models** – the safety belt for small shoppers on tour.

## Standard colours

### Plastic car top:

Standard two-tone design:

Ultramarine blue	RAL 5002	
Melon yellow	RAL 1028	

### Chassis and baskets:

FunMobil 80	
Flame red	RAL 3000
Ultramarine blue	RAL 5002
FunMobil Compact 140	
High-gloss, galvanised, chrome-plated	

**Advertising insert on handle:** screen-printed with non-fading inks.

**FunMobil 80 standard equipment:** Plastic body with chassis of oval tubing. Wire basket with child safety seat. Safety belt in the car as standard, integrated head and leg protection. Plastic end caps.

**Finish:** Plastic powder coating. Chassis Ultramarine blue RAL 5002, basket Fire Red RAL 3000.

**Castors:** 4 original Wanzl swivel castors Ø 125 mm, incl. one castor with brake, 5th castor Ø 100 mm, rubber tread

**FunMobil Compact 140 standard equipment:** Plastic body with chassis of oval tubing. Wire shopping baskets. Safety belt in the car as standard, integrated head and leg protection. Plastic end caps.

**Finish:** Chassis and baskets are high-gloss galvanised and chrome-plated with baked-on plastic paint protection.

**Castors:** 4 original Wanzl swivel castors Ø 125 mm, incl. one castor with brake, 5th castor Ø 100 mm, rubber tread

FunMobil 80	
<b>Order no.</b> (plastic powder-coated)	05.31 753.95
A x B x C, length x width x height (mm)	1450 x 595 x 1002
Basket volume (litres)	80
Castor Ø / 5th wheel Ø (mm)	125/100
Weight (kg)	34
Loading capacity (kg)	80
Advertising space, width x height (mm)	200 x 117
<b>Accessories</b>	<b>Order no.</b>
Wanzl-Box Classic coin deposit system, €1 / 50 cent	01.70 580.92
Flagpole, neutral flag	

FunMobil Compact 140	
<b>Order no.</b> (high-gloss, galvanised, chrome-plated + painted)	05.34 918.95
A x B x C, length x width x height (mm)	1300 x 640 x 1100
Basket volume (litres)	140
Castor Ø / 5th wheel Ø (mm)	125/100
Weight (kg)	43
Loading capacity (kg)	140
Advertising space, width x height (mm)	200 x 117
<b>Accessories</b>	<b>Order no.</b>
Wanzl-Box Solid coin deposit system, €1 / 50 cent	01.94 151.92
Flagpole, neutral flag	

# 01.08 Trend Baby Seat

Total focus on customers who are new parents

- > Stylish and very comfortable for the baby
- > Two-component construction consisting of a hard shell and soft cushioning
- > Safety first: available only fully assembled on shopping trolleys!\*



"TREND" BABY SEAT



Pat. pend.

**STANDARD COLOUR OF CUSHIONING**

Flame red	RAL 3000
-----------	----------

Other colours available on request



**CONTROLLED SUPPLY**  
Example: Trolley parks with Wanzl-Classic coin deposit system. On request.



**STANDARD**  
1 brake at the back of the shopping trolley.



**INFORMATION PANEL**  
for wall mounting, 600 x 1000 mm polystyrene, white.

**Standard equipment:** Stiff plastic shell with soft, UV-resistant cushioning. Washable material. Heavy-duty black three-point belt with plastic quick-lock buckle. Safety instructions on the baby seat. Fastening parts high-gloss galvanised and chrome-plated.

\* Please note: For safety reasons, Trend baby seats cannot be mounted separately.

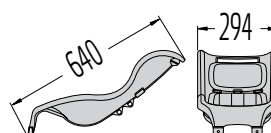

**"Trend" baby seat**



Fits	Shopping trolley model
EL series	EL 155**
ELA series	ELA 155**
DRC series	D155RC
Tango series	Tango 160E and P
MUC series	MUC 200, 300 and 400
Weight	1.9
Accessories	Order no.
Information board for wall mounting	01.35 145.07

\*\* More information on this Wanzl shopping trolley model available on request.



# 01.09 Rack for Infant Car Seat

Added service for shoppers with babies in car seats

- > Especially comfortable for the baby as it can stay in its own car seat
- > Fits virtually all infant car seat models available in the market
- > Safety first: available only fully assembled on shopping trolleys!\*



**HOLDER FOR BABY SAFE**  
made of wire  
(fig. similar)



**CONTROLLED SUPPLY**  
Example: Trolley parks with Wanzl-Classic coin deposit system. On request.



**STANDARD**  
1 brake at the back of the shopping trolley.



**INFORMATION PANEL**  
for wall mounting, 600 x 1000 mm polystyrene, white.

**Standard equipment:** Wire tray, can be nested. High-gloss galvanised, chrome-plated finish with baked-on plastic paint protection. Heavy-duty belt with plastic quick-lock buckle for safe fixing of the infant car seat. Safety instructions on the tray.

\* Please note: For safety reasons, infant car seat racks cannot be mounted separately.

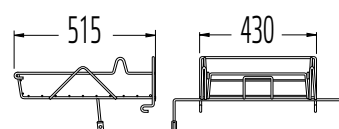

**Holder for baby safe**

Belt with quick-lock buckle



Fits	Shopping trolley model
EL series	EL 155**
ELA series	ELA 155**
DRC series	D155RC
Tango series	Tango 160E and P
Weight	2.2
Accessories	Order no.
Information board for wall mounting	01.35 148.07

\*\* More information on this Wanzl shopping trolley model available on request.

# 01.10 MUC<sup>®</sup> Series Shopping Trolleys

*Shopping convenience for many sectors*

- › *Custom configurations*
- › *Generous loading areas, extreme stress capacities*
- › *Easy, convenient handling*



**MUC<sup>®</sup> 900 S**  
Illustration shows optional  
equipment

Pat. pend.

# 01.10 MUC® Series Shopping Trolleys

## Multi-talented

The Multi-Cart shopping trolley series combines generous loading areas, extreme stress capacities and easy handling for outstanding customer convenience.

### Attractive colours optional

**Standard colours** for deflector profile, handle caps / Promobox plus with handle caps, small item tray\*, bag hook, back/front\*.

**Advertising insert on handle:** screen-printed with non-fading inks.

\* Accessories available on request

#### STANDARD COLOURS MUC® 200, 300, 400, 950:

Flame red	RAL 3000	
Ultramarine blue	RAL 5002	
Anthracite grey	RAL 7016	

#### BASKET AND FLAP COLOURS MUC® 900 S:

Flame red	RAL 3000	
Ultramarine blue	RAL 5002	
Slate grey	RAL 7015	

Custom colours available on request for 500 units or more

**Standard equipment:** Chassis of robust flat oval tubing with bumper profiles. Tightly meshed wire platform. Plastic deflector rings in Anthracite grey RAL 7016.

**Finish:** High-gloss galvanised and chrome-plated with baked-on plastic paint protection.

**Castors, MUC® 200, 300, 400, 950 and 900 S:** Original Wanzl swivel castors, rubber tread.

#### With wire basket:

MUC® 200 with basket

MUC® 300 with swivel basket and small items basket

MUC® 400 with basket

MUC® 950 with basket and long platform

#### With innovative polypropylene basket:

MUC® 900 S

	MUC® 200	MUC® 300	MUC® 400	MUC® 950	MUC® 900 S
<b>Order no.</b> (high-gloss, galvanised, chrome-plated + painted)	05.06 115.51	05.21 189.51	05.52 138.51	05.43 800.51	05.43 500.51
A x B x C, length x width x height (mm)	1020 x 600 x 1020	1020 x 600 x 1020	1230 x 675 x 1010	1306 x 600 x 1006	1008 x 616 x 1001
Basket volume (litres)	26	29	48	14	90
Castor Ø (mm)	125	125	125	125	125
Weight (kg)	24	23.5	30	21.5	26
Loading capacity (kg)	250	250	250	250	250
Nesting depth per trolley (mm)	250	275	350	315	315
Space required for 10 trolleys (mm)	3,270	3,495	4,380	4,141	3,843
Space required for 50 trolleys (mm)	13,270	14,495	18,380	16,741	16,443
<b>Accessories</b>					
Wanzl-Box Classic coin deposit system, €1 / 50 cent	01.75 020.92	01.75 020.92	01.75 035.92	01.75 020.92	-
Wanzl-Promobox plus coin deposit system, €1 / 50 cent	01.61 065.00	01.61 070.00	01.61 080.00	01.80 344.00	01.80 344.00
Wanzl-Box Solid coin deposit system, €1 / 50 cent	01.94 045.92	01.94 060.92	01.94 170.92	01.94 060.92	-

# 01.11 SP Special Transporter

*Takes care of heavy transport with ease*

- > Bulk carriage without excessive energy input or risk of back injury
- > Ergonomically shaped handles and ample leg room
- > Handle available in 5 standard colours

**SIDEBOX®**  
Coin deposit  
system,  
accessories

Pat. pend.  
Design pend.



SP3

# 01.11 SP Special Transporter

■ **DIY centres** use the SP special transporter wherever bulky items and heavy construction materials need to be moved without using excessive energy. With skids as standard, it is also easy to nest.

## Risk of injury prevented

The **buffer** on the handle prevents injuries when transporting sheet materials.



## Ample leg room

It's **easy to push** the trolley without risk of injury.



## Practical detail for bags

The **holder** on the handle holds bags.



## Colours, optional

**Standard colours** available for the handles. For CI-compliant design.

Flame red	RAL 3000	
Pure orange	RAL 2004	
Traffic green	RAL 6024	
Ultramarine blue	RAL 5002	
Anthracite grey	RAL 7016	

Special colours available on request.

**Standard equipment:** Frame construction made of flat oval tubing, upright bars of round tubing. Wooden platform edged with a protective frame of square tubing. Quiet operation thanks to cushion roller and rubber buffer construction. Plastic handles with tilted grip area ensure fatigue-free wrist positioning.

**Finish:** High-gloss galvanised and chrome-plated with baked-on plastic paint protection.

**Castors:** Original Wanzl bonded-on castors, rubber treads.

## Water and frost-proof

**Veneered platform** with non-slip screen embossing\* ensures longevity.

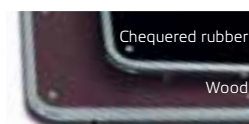

\* Chequered rubber surface available on request, standard on trolleys for travelators.

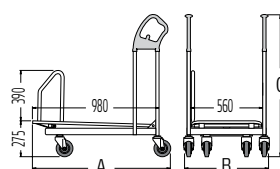

	SP 2	SP3	SP 5
<b>Order no.</b> (high-gloss, galvanised, chrome-plated + painted)	05.20 456.51	05.20 457.51	05.64 684.51
A x B x C, length x width x height (mm)	1070 x 675 x 1100	1070 x 675 x 1100	1330 x 790 x 1130
Basket volume (litres)	-	-	-
Castor Ø (mm)	125	125/160**	160
Weight (kg)	31	32	41
Loading capacity (kg) / Recommended load (kg) / On travelator (kg)	400 / 300 / 130	400 / 300 / 130	400 / 300 / 130
Nesting depth per trolley (mm)	300	300	330
Space required for 10 trolleys (mm)	3,770	3,770	4,300
Space required for 50 trolleys (mm)	15,770	15,770	17,500
<b>Accessories</b>			
Wanzl-Sidebox coin deposit system, €1	01.20 100.01-0001	01.20 100.01-0001	01.20 095.01-0001

\*\* On request.

# 01.12 Furniture Trolleys

*Driving revenues in cash and carry furniture stores*

- › *Agile and easy to manoeuvre, even when fully loaded*
- › *Ergonomic handles and ample leg room*
- › *Compact design enables nesting to save space*

**SIDEBOX®**  
Coin deposit  
system,  
accessories

Pat. pend.  
Design pend.



FURNITURE TROLLEYS

# 01.12 Furniture Trolleys

■ **The all-purpose transporter** for furniture, accessories and decorative items. Its greatest advantage is that it can still easily be manoeuvred even when fully loaded, using minimal energy. Comes as standard with skids for easy nesting.

## Practical details

**The buffer** on the handle prevents injuries when transporting large packages. **The holder** on the handle holds bags.



## Ample leg room

**It's easy to push** the trolley without risk of injury.



## Large skids with plastic profile

on the "Special" furniture trolley models make nesting even easier.



## Colours, optional

**Standard colours** available for the handles. For CI-compliant design.

Flame red	RAL 3000	
Pure orange	RAL 2004	
Traffic green	RAL 6024	
Ultramarine blue	RAL 5002	
Anthracite grey	RAL 7016	

Special colours available on request.

## 3 platforms

**Wire platform** (standard)  
Wooden platform and wooden platform with chequered rubber support.



**Standard equipment:** Frame construction made of flat oval tubing, upright bars of round tubing. Wire platform with double wire edging and skids. Plastic handles with tilted grip area. Plastic deflector rings in Anthracite grey RAL 7016.

**Finish:** High-gloss galvanised and chrome-plated with baked-on plastic paint protection.

**Castors:** Original Wanzl swivel castors, rubber tread.

Furniture trolleys	Standard	Special
<b>Order no.</b> (high-gloss galvanised, Cr-plated + painted)	05.50 482.51	05.34 239.51
A x B x C, length x width x height (mm)	1015 x 720 x 995	1210 x 710 x 1100
Mesh size of wire platform (mm)	40 x 160	60 x 50
Castor Ø (mm)	125	125
Weight (kg)	21	24
Loading capacity (kg)	200	200
Nesting depth per trolley (mm)	290	380
Space required for 10 trolleys (mm)	3,625	4,640
Space required for 50 trolleys (mm)	15,225	19,830
<b>Accessories</b>		
Wanzl-Sidebox coin deposit system, €1	01.20 100.01-0001	01.20 100.01-0001

# 01.13 Scandy S

*Shopping trolleys that sell well at all levels*



- > Plenty of room for all sorts of items
- > Two separate tightly meshed baskets with a total volume of 117 litres.
- > Spacious bottom tray suitable for through-loading



SCANDY S

## Colours, optional

**Standard colours** for plastic parts

Flame red	RAL 3000	
Traffic green	RAL 6024	
Ultramarine blue	RAL 5002	
Light grey	RAL 7035	

**Advertising insert on handle:** screen-printed with non-fading inks.

**Standard equipment:** Robust chassis of flat oval tubing, long bottom tray as standard. Two tightly meshed baskets with a total volume of 117 litres. Round tubular handle, plastic handle caps and deflector rings in Anthracite grey RAL 7016.

**Finish:** High-gloss galvanised and chrome-plated with baked-on plastic paint protection.

**Castors:** Original Wanzl castors, rubber tread.

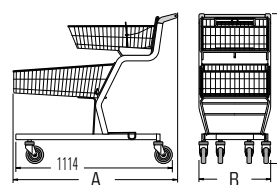

Scandy S



<b>Order no.</b> (high-gloss, galvanised, chrome-plated + painted)	02.51 603.51
A x B x C, length x width x height (mm)	1179 x 580 x 1087
Basket volume (litres)	upper 52 / lower 65
Castor Ø (mm)	125
Weight (kg)	28
Loading capacity (kg)	167
Nesting depth per trolley (mm)	270
Space required for 10 trolleys (mm)	3,609
Space required for 50 trolleys (mm)	14,409
<b>Accessories</b>	<b>Order no.</b>
Child seat/goods shelf	On request
Wanzl-Classic coin deposit system, €1 / 50 cent	01.70 580.92



# 01.14 GC 100-3

*The elegant shopping trolley solution*





- > For small, fragile items and for large, heavy items
- > 100 litre main basket plus small items basket attachable in 2 positions
- > Large non-slip wire platform



GC 100-3 Design pend.

## Colours, optional

**Standard colours** for plastic parts

Flame red	RAL 3000	
Traffic green	RAL 6024	
Ultramarine blue	RAL 5002	
Light grey	RAL 7035	

**Advertising insert on handle:** screen-printed with non-fading inks.

**Standard equipment:** Robust chassis of flat oval tubing with non-slip wire platform. Tightly meshed baskets; the upper one comes with child safety seat as standard, the lower one is ideal for fragile small items. Round tubular handle, plastic handle caps.

**Finish:** High-gloss galvanised and chrome-plated with baked-on plastic paint protection.

**Castors:** Original Wanzl castors, rubber tread.



GC 100-3



Order no. (high-gloss, galvanised, chrome-plated + painted)	02.46 557.51
A x B x C, length x width x height (mm)	1180 x 605 x 1100
Basket volume (litres)	upper 100
Castor Ø (mm)	125
Weight (kg)	34.5
Loading capacity (kg)	200
Nesting depth per trolley (mm)	270
Space required for 10 trolleys (mm)	3,610
Space required for 50 trolleys (mm)	14,410
Accessories	Order no.
Optional: Wanzl bonded-on castors, castor Ø (mm)	160
Wanzl-Classic coin deposit system, €1 / 50 cent	01.70 580.92

# 01.15 Gardener 100

Practical shopping trolley for garden centres, nurseries, etc.

- > Equipped with pneumatic tyres for especially light running
- > Anti-tipping device as standard. Easily nested
- > Practical accessories: the removable GT26 eco for smaller items\*







COMFORT  
HANDLE AND  
GT26 eco

Design pend.

**GARDENER 100**  
with GT26 eco accessory

## Colours, optional

**Standard colours** for plastic parts



Flame red	RAL 3000	
Traffic green	RAL 6024	
Ultramarine blue	RAL 5002	
Anthracite grey	RAL 7016	

**Advertising insert on handle:** screen-printed with non-fading inks.

**Standard equipment:** Robust chassis of flat oval tubing and tightly meshed wire basket. Round tubular handle, plastic handle caps in Anthracite grey RAL 7016.

**Finish:** High-gloss galvanised and chrome-plated with baked-on plastic paint protection.

**Castors:** 2 wheels with pneumatic tyres, black treads.

Gardener 100	
	
<b>Order no.</b> (high-gloss, galvanised, chrome-plated + painted)	05.66 332.51
A x B x C, length x width x height (mm)	1225 x 746 x 863
Basket volume (litres)	upper 26 / lower 100
Wheel Ø (mm)	260
Weight (kg)	15.6
Loading capacity (kg)	110
Nesting depth per trolley (mm)	350
Space required for 10 trolleys (mm)	4,375
Space required for 50 trolleys (mm)	18,375
<b>Accessories</b>	<b>Order no.</b>
GT26 eco shopping basket	02.55 823.07
Wanzl-Sidebox coin deposit system, €2	01.20095.C3-0001

# 01.16 Planter D + P

Practical shopping trolley for garden centres, nurseries, etc.

- > Planter P: Moisture and solid from rooted plants is safely captured
- > Basin and wire basket can be folded up to allow trolley nesting
- > Practical accessories: the removable GT 26 eco for smaller items\*







**PLANTER D**  
with GT26 eco accessory

**PLANTER P**  
with GT26 eco accessory

**PLANTER D + P**  
Can be nested to save space

## Basket GT26 eco

Design pend.



Orange	RAL 2006	
Magenta	RAL 4206	
Blue	RAL 5212	
Green	RAL 6218	



**Design:** Robust chassis of flat oval tubing with tightly meshed wire basket or with basin, can be folded up to allow trolley nesting. Plastic basin, round tubular handle with advertising insert and plastic sheathing.

**Finish:** High-gloss galvanised and chrome-plated with baked-on plastic paint protection.

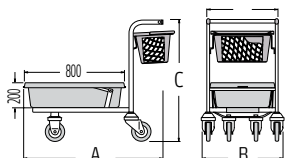
**Castors:** 2 swivel castors, 2 fixed castors, on ball bearings, rubber tread.

High-gloss, galvanised, chrome-plated + painted	Planter D	Planter P
		
<b>Order no.</b>	05.68 931.51-V001	05.68 941.51-V001
A x B x C, length x width x height (mm)	1035 x 629 x 968	1114 x 629 x 971
Basket volume D / basin volume P (litres)	55	50
Castor Ø (mm)	160	160
Weight (kg)	27	27
Loading capacity (kg)	100	100
Nesting depth per trolley (mm)	400	400
Space required for 10 trolleys (mm)	4,714	4,714
Space required for 50 trolleys (mm)	20,714	20,714
<b>Accessories</b>	<b>Order no.</b>	<b>Order no.</b>
GT26 eco shopping basket	02.55 823.07	02.55 823.07
Wanzl-Sidebox coin deposit system, €2	01.20098.C3-0001	01.20098.C3-0001

# 01.17 Shopping Trolley Accessories

*Corporate design and for convenience*

- › *Effective advertising inserts – the ideal location for your logo*
- › *Reading aids for your convenience*
- › *Comfort handles simplify trolley handling for your customers*



Design pend.

**COMFORT HANDLE**  
Accessories

# 01.17 Shopping Trolley Accessories

■ **Effective advertising spaces** generate lots of added value for little added cost.  
**Furthermore:** convenience is perceived positively, which enhances customer loyalty.

## Advertising inserts



**In tubular handles:** round tubular handle with advertising insert and plastic sheathing.

**In the Wanzl-Promobox® plus:** effective, generous advertising space, 297 x 67 mm.

**Implementation for both designs:** screen-printed on plastic film with non-fading inks as per your instructions.

## Bag hook, flower holder...



**Additional accessories** offering even more convenience to customers, thus further enhancing customer loyalty, include: child safety seat, bag hook front/back, wire tray, plastic tray, small item wire basket, cross divider, basket corner protectors top/bottom, basket protection profile, cut flowers holder, Wanzl travelator castors, etc., and are available on request.

## Promobox® with integrated magnifying glass or reading aid on the handle of the shopping trolley

**Both to enable easier reading.**  
 A convenience for customers who didn't bring a reading aid with them.



## More convenience with the Wanzl Comfort handle

**The ergonomically shaped handle** makes pushing and steering shopping trolleys a pleasure for your customers.

**Design:** Plastic handle, optionally equipped with integrated Wanzl-Starbox coin deposit system. For shopping trolleys with a basket volume of 101 litres or more. Can be mounted on models with standard handle caps on request.

Wanzl-Comfort-handle

Standard colours*	
Flame red	RAL 3000
Ultramarine blue	RAL 5002
Anthracite grey	RAL 7016

\* Special colours on request

# 01.18 Coin deposit systems

*More convenience for your customers and markets*

- > *Trolleys made readily available securely*
- > *Without staff intervention*
- > *Simple to use coin slot*

Pat. pend.  
Design pend.

**WANZL-PROMOBOX® PLUS**  
Coin deposit system



# 01.18 Coin deposit systems

■ **Original-coin deposit systems** ensure that trolleys are returned to where they belong, without staff intervention.

## Coin deposit systems\*

Wanzl-Classic	Wanzl-Starbox®	Wanzl-Box Solid	Wanzl-Promobox® plus	Wanzl-Sidebox®**
<p><b>Design:</b></p> <p>Casing made of impact-resistant, unbreakable plastic integrated into the handle cap. Proven coin slide operation. Chain and key of high-quality stainless steel.</p>	<p><b>Design:</b></p> <p>Housing of impact-resistant, unbreakable plastic integrated into the handle cap. Operation with coin slot. Chain and key of high-quality stainless steel.</p>	<p><b>Design:</b></p> <p>Casing made of impact-resistant, unbreakable plastic. Can be positioned anywhere on the handle. Reliable coin slide operation. Chain and key of high-quality stainless steel.</p>	<p><b>Design:</b></p> <p>Trapezoidal design with ergonomic grip area. Coin deposit via coin slot. Stainless steel chain, high-strength light alloy key. Compartment for transponder or RFID components.</p>	<p><b>Design:</b></p> <p>Ergonomically designed high-quality plastic casing with coin deposit via coin slot. Chain with stainless steel key. Mounting with adapter or directly on the plastic handle.</p>
<b>Standard colours</b>				
Flame red RAL 3000	Flame red RAL 3000		Flame red RAL 3000	
Ultramarine blue RAL 5002	Ultramarine blue RAL 5002		Ultramarine blue RAL 5002	
	Anthracite grey RAL 7016		Anthracite grey RAL 7016	Anthracite grey RAL 7016
Casing and lock	lock	Casing and lock		Coin insertion area
Light grey RAL 7035	Light grey RAL 7035	Light grey RAL 7035		Light grey RAL 7035

\* On request    \*\*Only for SP special transporter, Gardener 100 and Planter D + P

# 01.19 Shopping Baskets

*The right helpers for the small shopping trip*

- > *Models tailored to your product range*
- > *All models are tilt-safe and reliable*
- > *Made from plastic or wire*



**GT26 eco AND KOWA ST**  
Shopping baskets and basket stackers with push bars

**HWK 16 AND KOWA ST**  
Shopping baskets and basket stackers with push bars

**WA 20 AND KOWA ST**  
Shopping baskets and basket stackers with push bars

**OV 17 AND KOWA ST**  
Shopping baskets and basket stackers with push bars

**HW 0**  
Shopping baskets

Design pend.

Pat. pend.



# 01.19 Shopping Baskets

■ **Tried and tested a million times** – in all kinds of design.  
Made from plastics or wire.





## An ecological highlight:

The **GT26®** is available in a "GT26 eco" version made from recycled materials. 4 selected handle colours available.



## GT26 eco basket

Design pend.

Orange	RAL 2006	
Magenta	RAL 4206	
Blue	RAL 5212	
Green	RAL 6218	



## Standard equipment – plastic:

**GT26®:** Tightly meshed stackable polypropylene baskets.  
**WA 20 and HWK 16:** Stackable, tightly meshed plastic baskets. Self-latching interior carry handles made of wire with plastic grips contoured to the shape of hands or made of plastic.











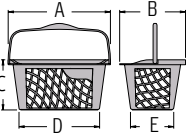



## Standard equipment – wire:

**OV 17 and HW 0:** Stackable wire baskets with tightly meshed bottoms. Self-latching carry handles with plastic grips contoured to the shape of hands.  
**Finish:** High-gloss, galvanised, chrome-plated. HW 0 available on request in high-gloss brass-plated, or in coloured plastic powder-coated finish.

## Shopping baskets made of:

### Plastic

### Wire

	GT26®	WA 20	HWK 16	OV 17	HW 0
Scale drawing Example: GT 26®					 Pat. pend.
<b>Order no.</b>	02.23 845.07	02.50 730.07	02.04 870.07	02.02 713.10	02.03 443.10
A x B x C, length x width x height (mm)	520 x 335 x 255	440 x 272 x 205	450 x 275 x 190	436 x 275 x 202	360 x 225 x 120
D x E, base area, length x width (mm)	410 x 220	344 x 210	355 x 210	335 x 220	285 x 180
Basket volume (litres)	26	20	16	17	7
Weight (kg)	0.75	0.5	0.7	1.0	0.8
Loading capacity (kg)	26	20	16	17	7
<b>Standard colours – baskets</b>	Flame red RAL 3000 	Flame red RAL 3000 	Traffic green RAL 6024 	high-gloss chrome-plated	high-gloss chrome-plated
	Ultramarine blue RAL 5002 	Traffic blue RAL 5017 	Pebble grey RAL 7032 		
	Traffic green RAL 6024 	Emerald green RAL 6001 			
	Anthrax grey RAL 7016 				
<b>Accessories</b>					
Basket stacker	-	02.03 906.73-7184	02.03 906.73-7184	-	-
Basket stacker with push bar	02.03 907.73-7184	02.03 907.73-7184	02.03 907.73-7184	02.02 600.73-7184	02.05 815.10
Tray for small items, grey	-	-	-	00.15 949.07-9006	-

# 01.20 Take 2 and Shop & Roll

*The smart shopping trolley systems for the small shopping trip*

- > *Maximum shopping convenience and extra customer appreciation*
- > *Main basket or basic for a small neighbourhood shop*
- > *Take 2: Ideal for smaller stores combined with the GT26 shopping basket*



Design pend.  
GT26 eco

**TAKE 2**  
Shopping trolley system  
with two GT26 ecos



Custom branding on request.

**SHOP & ROLL**  
Shopping trolley system



# 01.20 Take 2 and Shop & Roll

■ **Flexible shopping** in line with your customers' needs. With Take 2 and removable GT26 shopping baskets or Shop & Roll – both can be chosen to match your product range.



**GT26 ECO**  
for the really small shopping trip

**TAKE 2**  
equipped with two GT26 ecos

**TAKE 2**  
Can be nested to save space



**SHOP & ROLL**  
Folding carry handle in use

**SHOP & ROLL**  
Telescopic handle for pulling

**3 standard colours available**

Traffic red	RAL 3020	
Signal blue	RAL 5005	
Anthracite grey	RAL 7016	



Simple to stack, easy to supply

**Take 2 standard equipment:** Light yet robust round tubing construction in Anthracite grey RAL 7016.

**Castors:** 2 fixed castors Ø 75 mm (back)

**Finish:** Plastic powder-coated, RAL 7016.

**Choice of baskets:** GT26, GT26 eco.

**Shop & Roll standard equipment:** Tightly meshed polypropylene plastic basket in three attractive, fresh colours. Integrated telescopic aluminium pole and additional carry handle, designed for daily use.

**Castors:** 2 stable rollers with rubber treads, Ø 40 mm.

Take 2	
<b>Order no.</b> (high-gloss chrome-plated + painted)	02.60 117.76-7016
A x B x C, length x width x height (mm)	422 x 442 x 1002
Castor Ø (mm)	75
Weight (kg)	3
Loading capacity (kg)	40
Nesting depth per trolley	75
Space required for 10 trolleys (mm)	1097
Space required for 50 trolleys (mm)	4097
<b>Accessories</b>	
Shopping basket*	

Shop & Roll	
<b>Order no.</b> Polypropylene	02.26 443.07
A x B x C Length x width x height (mm)	465 x 353 x 913
D x E Base area, length x width (mm)	350 x 200
F Basket height (mm)	404
G Basket with raised carry handle (mm)	564
Castor Ø (mm)	40
Weight (kg)	0,7
Loading capacity (kg)	34

\* Order numbers for GT26 and GT26 eco shopping baskets are shown on page 39 and page 35, respectively

# 01.21 Row Docking Stations

Secure in-store and outdoor supply of shopping trolleys

- > Row docking stations in single, double or triple configurations
- > Can be combined with existing or new Wanzl Classic customer guidance systems
- > Locating them at the entrance and in the car park reduces distances for customers.



**IN-STORE ROW DOCKING STATION**  
2 rows, with information panel frame and panel

In-store row docking station	1-part	2-part	3-part			
<b>High-gloss chrome-plated</b> Delivery includes: Row docking station Row docking key						
<b>Row docking key for:</b>	<b>Order no.</b>	<b>Order no.</b>	<b>Order no.</b>			
Starbox / Classic / Solid	23.69 594.10	23.69 595.10	23.69 596.10			
Promobox Plus	23.78 113.10	23.78 114.10	23.78 115.10			
Sidebox	23.49 513.10	23.49 514.10	23.49 515.10			
<b>Standard assembly</b>						
1 screw M10 x 60 order 4 units per upright		90.11 274.50				
1 dowel M10, PVC order 4 units per upright		91.07 196.00				
Outdoor row docking station	1-part	2-part	3-part			
<b>Hot galvanised</b> Delivery includes: Row docking station Row docking key Fixings						
<b>Assembly method</b>	① Set in concrete	② Dowel	① Set in concrete	② Dowel	① Set in concrete	② Dowel
<b>Row docking key</b>	<b>Order no.</b>	<b>Order no.</b>	<b>Order no.</b>	<b>Order no.</b>	<b>Order no.</b>	<b>Order no.</b>
for Starbox / Classic / Solid	23.70 341.55	23.70 342.55	23.70 343.55	23.70 344.55	23.70 345.55	23.70 346.55
for Promobox plus	23.55 412.55	23.55 413.55	23.55 414.55	23.55 415.55	23.55 416.55	23.84 637.55
for Sidebox	23.49 752.55	23.49 753.55	23.49 754.55	23.49 755.55	23.49 756.55	23.49 757.55

# 01.21 Row Docking Stations

■ **Customers** appreciate this added convenience. One component of this service system are the row of docking stations for attaching shopping trolleys.

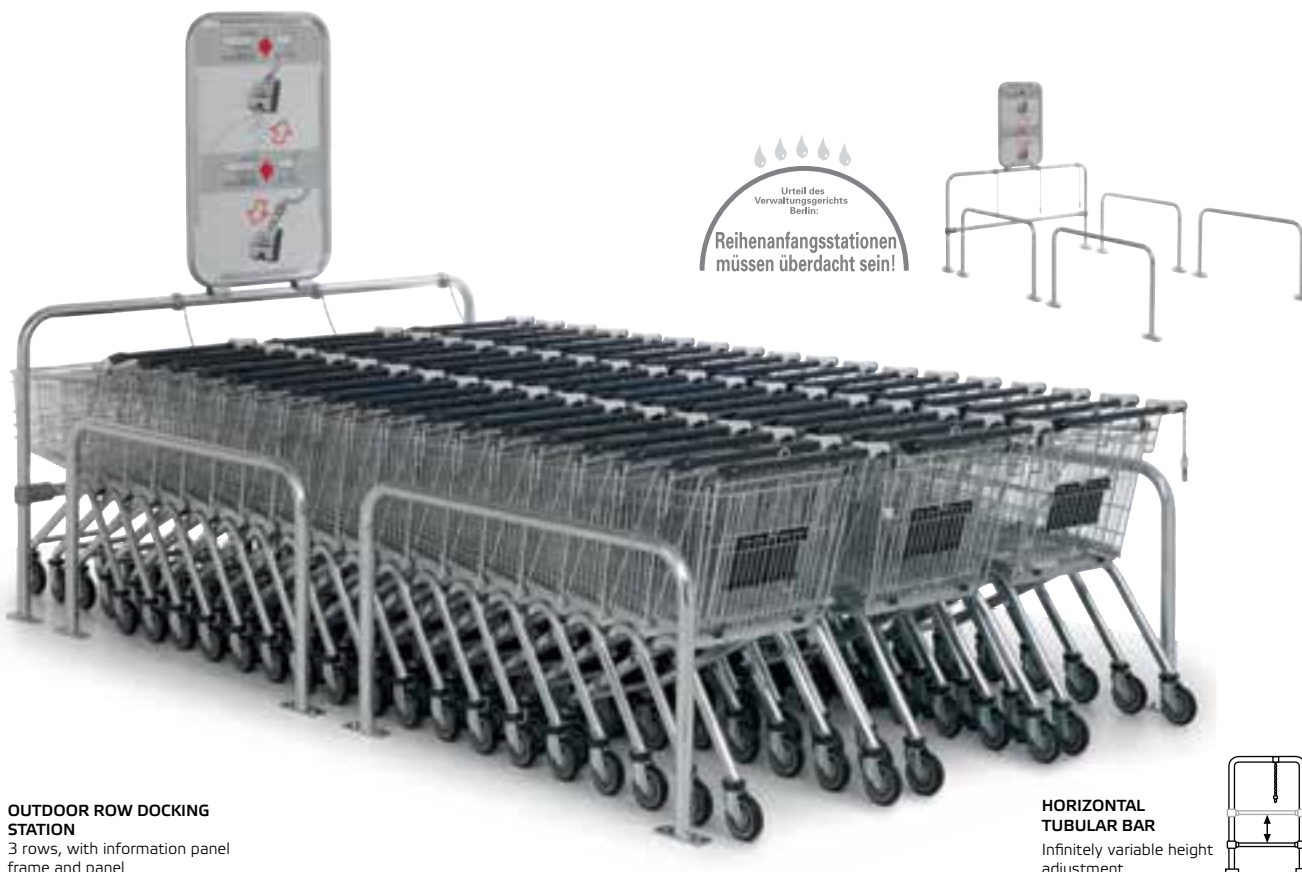

**OUTDOOR ROW DOCKING STATION**  
3 rows, with information panel frame and panel

**HORIZONTAL TUBULAR BAR**  
Infinitely variable height adjustment.

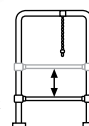

**In-store row docking station – standard equipment:** Robust tubular construction, uprights  $\varnothing$  50 mm with metal connection sleeves. Connection tubes  $\varnothing$  40 mm. Row docking key with chain and connection sleeve for  $\varnothing$  40 mm, chain length 500 mm.  
**Finish:** High-gloss chrome-plated.

**Outdoor row docking station – standard equipment:** Row docking stations of robust steel tubing  $\varnothing$  50 mm. Horizontal tubular bar  $\varnothing$  50 mm, infinitely variable height adjustment. Row docking key with chain for  $\varnothing$  50 mm tube, chain length 500 mm.  
**Finish:** Hot galvanised.

Accessories																		
Information panel frame		for in-store row docking station	for outdoor row docking station															
	Information panel frame tubing $\varnothing$ 32 mm incl. fixings	High-gloss chrome plated 23.38 998.10	Hot galvanised 23.38 981.55															
	Information panel (plastic)* for																	
	coin deposit system	01.18 870.07	01.18 870.07															
	Classic / Solid	01.78 151.07	01.78 151.07															
	Promobox Plus	01.18 871.07	01.18 871.07															
	Sidebox	01.18 800.07	01.18 800.07															
	Guide rail for outdoor row docking station		<table border="1"> <thead> <tr> <th></th> <th>1 Set in concrete</th> <th>2 Dowel</th> </tr> </thead> <tbody> <tr> <td>1500 mm</td> <td>**</td> <td>23.45 537.55</td> </tr> <tr> <td>2000 mm</td> <td></td> <td>23.80 389.55</td> </tr> <tr> <td>2500 mm</td> <td></td> <td>23.80 391.55</td> </tr> <tr> <td>3000 mm</td> <td></td> <td>23.68 602.55</td> </tr> </tbody> </table>		1 Set in concrete	2 Dowel	1500 mm	**	23.45 537.55	2000 mm		23.80 389.55	2500 mm		23.80 391.55	3000 mm		23.68 602.55
	1 Set in concrete	2 Dowel																
1500 mm	**	23.45 537.55																
2000 mm		23.80 389.55																
2500 mm		23.80 391.55																
3000 mm		23.68 602.55																

\* printed on both sides · \*\*Uprights and connection tubes for side guides can be found in the Customer Guidance section on page 60 / 61.

# 01.22 Economy and Delta 2 Shelters

*Organised, hygienically covered supply of shopping trolleys*

- > *High-quality, robust and cost-effective solutions*
- > *Quality right up to the finest detail*
- > *Appealing design in attractive colours*



**DELTA 2 TROLLEY SHELTER**  
With row docking station

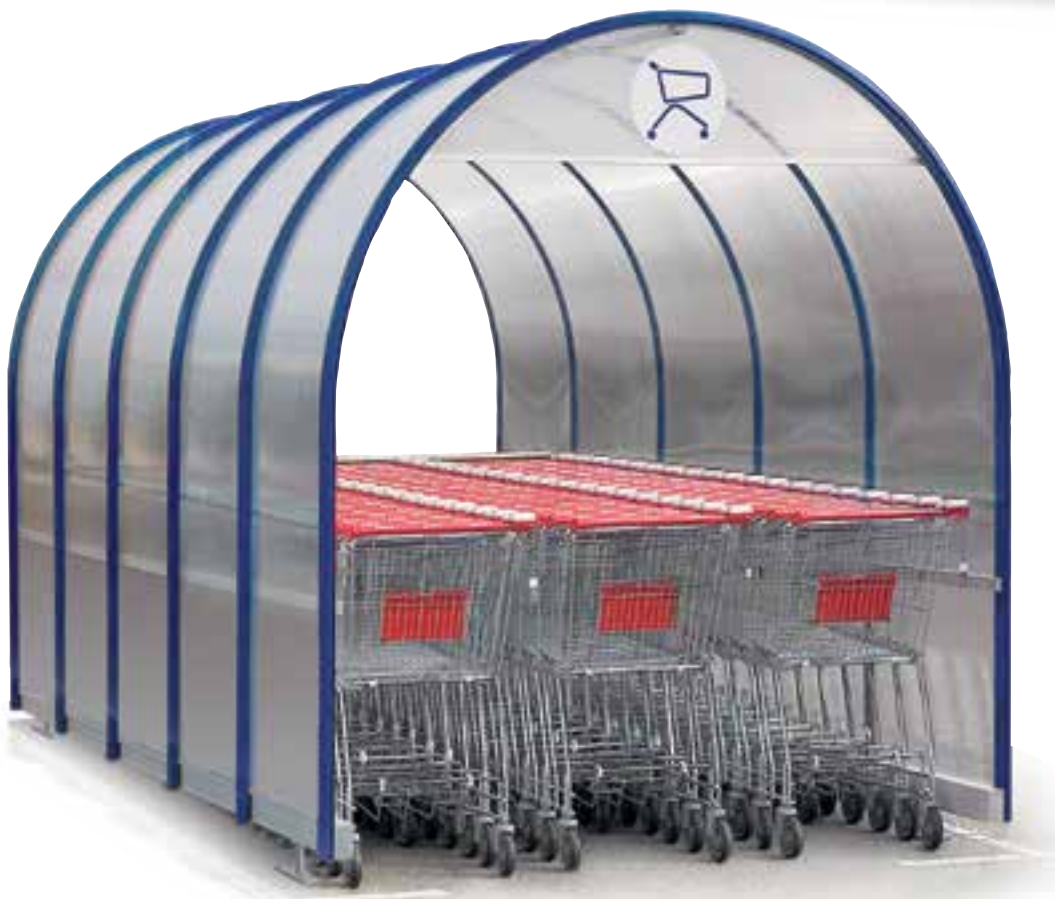

**ECONOMY TROLLEY SHELTER**  
With row docking station

# 01.22 Economy and Delta 2 Shelters

■ **Successful selling** begins in the car park – not only do customers appreciate the added convenience of shopping trolley shelters, they also meet statutory hygiene requirements.

## Quality in the details

**Economy:**  
1-part roof construction, dirt-resistant hollow-chamber panels

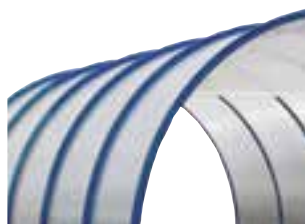

**Delta 2:**  
2-part roof construction. Side and roof components available in a choice of 3 materials.



## Economy

### Glazing and colours

#### Glazing – Economy

Hollow-chamber panels (polycarbonate)

#### Aluminium profiles – Economy

Anodised aluminium	
Flame red	RAL 3000
Ultramarine blue	RAL 5002

## Delta 2

### Glazing and colours

#### Glazing – Delta 2

Hollow-chamber panels (polycarbonate)	
Acrylic glass panels	on request
Plastic panels	on request

#### Aluminium profiles – Delta 2

Anodised aluminium	
Flame red	RAL 3000
Ultramarine blue	RAL 5002

**Standard equipment:** Stylish aluminium profiles, rounded on the outside. One-part side and roof components made from unbreakable polycarbonate hollow-chamber panels. Aluminium square tubes mounted on both sides function as a guide and a bumper for shopping trolleys. Infinitely height-adjustable feet compensate for uneven ground.  
**Finish:** Anodised aluminium or plastic powder-coated in 2 standard RAL colours.\*

**Standard equipment:** Stylish aluminium profiles, rounded on the outside. Two-part construction of side and roof components made from polycarbonate hollow-chamber panels. Aluminium square tubes and profiles mounted on both sides function as a guide and a bumper for shopping trolleys. Infinitely height-adjustable feet compensate for uneven ground.  
**Finish:** Anodised aluminium or plastic powder-coated in 2 standard RAL colours.\*

\* Custom colours or multi-colour configuration available on request.

Sample order: 3-row shelter, length 5 m		Economy
<b>Order no.</b>		
Anodised	03.83 702.45	
Plastic powder coating	03.83 702.73	
A x B x C, length x width x height (mm)	5000 x 2283 x 2430	
<b>Capacity:</b>		
Shopping trolley rows	3	
Shopping trolley rows with 90-litre basket volume (units)	108	
Shopping trolley rows with 130-litre basket volume (units)	60	
<b>Accessories</b>		<b>Order no.</b>
Row docking station, stainless steel, with 3 information panels	On request	
1/1 rear panel, complete	03.83 711.07	

Sample order: 3-row shelter, length 5 m		Delta 2
<b>Order no.</b>		
Anodised	03.33 834.45	
Plastic powder coating	03.33 834.73	
A x B x C, length x width x height (mm)	5000 x 2298 x 2479	
<b>Capacity:</b>		
Shopping trolley rows	3	
Shopping trolley rows with 90-litre basket volume (units)	108	
Shopping trolley rows with 130-litre basket volume (units)	60	
<b>Accessories</b>		<b>Order no.</b>
Row docking station, stainless steel, with 3 information panels	On request	
1/1 rear panel, complete	03.05 085.07	

# 01.23 Sigma Trolley Shelter

*Controlled, hygienically covered supply of shopping trolleys – day and night*

- › *Highly convenient operation when powered electrically*
- › *Protects your shopping trolleys against theft and the elements*
- › *Simple, timeless design – suits any style of architecture*



**SIGMA TROLLEY SHELTER**  
With row docking station

Utility model pend.



# 01.23 Sigma Trolley Shelter

■ **Illuminated Sigma trolley shelters serve as prominent orientation points** at shops with longer opening hours and during the short winter days. When it's dark after closing time, the all-round glass enclosure and the lockable roller shutter securely protect your shopping trolley against theft.

## Maximum protection for your shopping trolleys

During the day, dry and neatly arranged. At night, protected against theft and the elements on all sides with a roller shutter.



Utility model pend.



## Ease of use

**Operating the roller shutter:** mechanically with a hand crank, electrically with a convenient key switch.



## Standard colours\*

Flame red	RAL 3000	
Ultramarine blue	RAL 5002	
White aluminium	9206	

\* Custom colours and multi-colour configuration available on request.



**Design:** Stylish aluminium profiles, rounded on the outside. Side and roof components made from transparent acrylic glass panels. Aluminium square tubes with plastic profiles mounted on both sides function as a guide and a bumper for shopping trolleys. Infinitely height-adjustable feet compensate for uneven ground.

**Roller shutter:** Reinforced aluminium profiles with integrated guide and plastic protection profiles. Aluminium casing with rigid foam filling. The roller shutter can be operated with an electric motor or hand crank.

**Finish:** Available plastic powder-coated in standard colours.

## Design freedom

You can make up to three different shopping trolley models available to your customers in the Sigma trolley shelter.

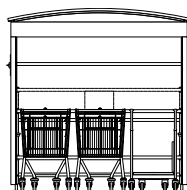

## Sigma

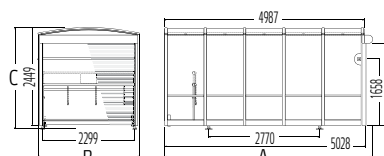

Basic model: Space for three rows of shopping trolleys

**Sigma SM - mechanical**

Order no.

03.33 901.73

**Sigma SE - electric**

03.30 290.73

A x B x C, length x width x height (mm)

5200 x 2536 x 2539

Capacity:

Shopping trolley rows

3

Shopping trolley rows with 90-litre basket volume (units)

108

Shopping trolley rows with 130-litre basket volume (units)

60

### Accessories

Order no.

Interior lighting, weather-proof, 58 watts

03.31 754.07

Folding frames, aluminium, 910 x 1170 mm

03.14 013.95

Plastic waste bin, yellow green RAL 6018 incl. fixings, 430 x 240 x 600 mm

03.69 035.07

Row docking station

On request

# 02 Product overview

## 02.01 – 02.03 Electronic Entry Systems



01 eGATE®



02 TECHNOPORT



03 ECOPORT

## 02.04 Checkout Barriers and Swivel Doors

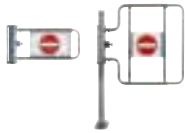

04 S CHECKOUT BARRIER, SELF-LOCKING



04 SWIVEL DOORS, MECHANICAL

## 02.05 – 02.06 Customer Guidance and Partitions

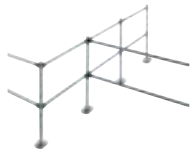

05 CLASSIC CUSTOMER GUIDANCE SYSTEM



06 RAILIX® PARTITIONS

## 02.07 Bumper Systems



07 BUMPER BARS



07 NX STAINLESS STEEL GUIDE RAILS



07 TECHNOLINE GUIDE RAILS



07 PRO TEC 3° BUMPER SYSTEM

## 02 Access Systems



## 02.01 eGate®

*The modern entrance system befitting the transition to new worlds of shopping*

- > *Elegant protection against inventory losses*
- > *Intelligent sensors and multifunctional high-tech equipment*
- > *Barrier-free and fully accessible to the disabled*



Pat. pend.

eGate®  
with Classic swivel arms, left-opening,  
with transparent plastic sign



Pat. pend.  
Design pend.



eGate®  
with ESG glass swivel arm,  
opening in both directions

### Optional equipment

Unauthorised exit alarm,  
Barrier manipulation alarm,  
Power supply from the ceiling,  
Digital counter,  
Wireless remote control,  
Control panel,  
Tandem radar,  
Customer frequency counter,  
Barrier stop,  
Fire alarm

**Equipment:** Aluminium column, coloured plastic powder-coated finish. Steel swivel mechanism, high-gloss chrome-plated casing, coloured plastic powder-coated or stainless steel finish. Classic swivel arms, high-gloss chrome-plated, with notice sign, transparent or white, printed on both sides.

**Control unit:** Radar with range from 0.5 up to 2.5 m and infrared light barrier for the second gate in two-gate systems.

**Technical equipment:** Systems comply with both national and international safety requirements. Operating voltage 24 V. Swivel arms open evenly, no swing back, exact positioning. Stepless adjustment of opening angle from 0° to 180° via teach-in process. Opening time adjustable between 1 and 15 seconds.

Opening direction can be switched on-site. RS485 interface, e.g. for data analysis and remote control via PC.

# 02.01 eGate®

## Multifunctional, high-quality entrance system

Delivers maximum inventory control in an open and friendly arrangement. eGate® can do both – can be perfectly integrated into its shopping environment and still offers maximum protection against theft.



Pat. pend.

**eGate®**  
Double system, with ESG glass swivel arm and lead-out section

eGate® Single system (plastic powder-coated)		with lead-out section rear connection tubes 1100 mm		With radar	Order no.		
<b>Operation:</b> - Opening signal controlled by radar. - Gate closes after the set open time. - Anti-panic feature with acoustic signal. - Gates automatically return to original position after anti-panic feature is triggered.	<p>1) Fig.: eGate® single system, right-opening, base model with lead-out section, radar control, Classic swivel arms and transparent plastic notice sign with arrow and no-entry symbols.</p>		Left-opening	23.14 504.10-0001			
			opens towards the right	23.14 505.10-0001			
eGate® Single two-gate system (plastic powder-coated)		with lead-through and lead-out sections rear connection tubes 1100 mm		with radar and light barrier	Order no.		
<b>Operation:</b> - Opening signal for the first gate controlled by radar. - Opening signal for the second gate triggered by interruption of the light barrier in the first gate. - Each gate closes after the set open time. - Anti-panic feature with acoustic signal. - Gates automatically return to original position after anti-panic feature is triggered.	<p>2) Fig.: eGate® single two-gate system, right-opening, base model with lead-through and lead-out sections, radar control and light barrier, Classic swivel arms and transparent plastic notice signs with arrow and no-entry symbols.</p>		Left-opening	23.14 512.10-0001			
			opens towards the right	23.14 513.10-0001			
Accessories							
Barrier or swivel arm	Length (mm)	Finish		Order no.			
 Pat pend. / Design pend.	Promotional barrier, back	850	High-gloss chrome-plated tubing, plastic tips, white or transparent plastic notice sign		On request		
 Design pend.	ESG glass swivel arm	850	Transparent single-pane safety glass custom sandblasting on request		On request		
Info sign	Dimensions (mm)			Front	Back	Order no.	
 Design pend.	for Classic swivel arms	400 x 237	Plastic, transparent				23.53 553.07
			White plastic				23.46 079.07
 Design pend.	for Promotional barrier	610 x 242	Acrylic glass, transparent				00.54 389.07
			White plastic				00.67 142.07
Electrical components							
	Power supply from top	230 V power supply* and 12 V signal lines from the ceiling. In this way, you can dispense with any building measures, conversion work is much easier.			77.86 815.10		
	Digital counter	Counts customers via direction-sensing radar Digital readout			98.73 883.00		
	Wireless remote control	Allows operator to enable access in passage and exit direction Permanent access is also possible			98.73 693.00		
	Operating panel	Single access and closure after set open time, permanent access and reverse-direction access e.g. for staff exit			98.72 914.00		

\* Warning: the power supply must be installed by specialist personnel.

## 02.02 Technoport®

*Entrance systems – your starting point for successful retailing*

- > *Multi-talented system to welcome customers and ensure safety*
- > *High-tech eye-catcher with features including radar control, light barriers and anti-panic feature*
- > *Barrier-free and fully accessible to the disabled*



**TECHNOPORT®**  
left-opening, with lead-out section

Pat. pend.

### Optional equipment

Unauthorised exit alarm,  
Barrier manipulation alarm,  
Power supply from the ceiling,  
Digital counter,  
Control panel,  
Barrier stoppage,  
Fire alarm

**Equipment:** Technoport column, swivel arms, uprights and connection tubes made from steel tubing. Stable base plates with sheet steel coverings.

**Control unit:** Opening signal via radar with range from 0.5 up to 2.5 m and infrared light barrier in two-gate systems.

**Technical equipment:** 230 V power supply through conduits in the floor or from the ceiling. Low 24 V operating voltage. Opens evenly and precisely to the left or right (can be switched on site) with no swing back, opening angles infinitely adjustable from 0° to 180°. RS485 interface as standard, LAN connection on request.

# 02.02 Technoport®

■ **With Technoport®**, you always start with a proper welcome for the customer, while protecting yourself against losses of inventory.

Single Technoport® (high-gloss chrome-plated)						
without lead-out section			With radar			
<b>Operation:</b> - Opening signal controlled by radar. - Gate closes after the set open time. - This function is identical for all systems. 1) Fig.: Single Technoport, right-opening, basic model, radar control		Left-opening	Order no. 23.73 371.10			
		opens towards the right	Order no. 23.73 370.10			
with lead-out section rear connection tubes 1000 mm			With radar			
<b>Operation:</b> see above  2) Fig.: Single Technoport, right-opening, basic model with lead-out section, radar control		Left-opening	Order no. 23.72 249.10			
		opens towards the right	Order no. 23.72 245.10			
Single Technoport®, two-gate (high-gloss chrome-plated)						
with lead-through and lead-out sections middle / rear connection tubes 1500 / 1000 mm			with radar and light barrier			
<b>Operation:</b> - Technoport systems open independently from each other. - Opening signal for the first gate controlled by radar. - Opening signal for the second gate triggered by interruption of the light barrier in the first gate. - The gates close after the set open time independently from each other. - This function is identical for all two-gate systems.  3) Fig.: eGate single two-gate system, right-opening, basic model with lead-through and lead-out sections, radar control and light barrier, Classic swivel arms and transparent plastic notice signs with arrow and no-entry symbols		Left-opening	Order no. 23.72 264.10			
		opens towards the right	Order no. 23.72 262.10			
Accessories						
Barrier or swivel arm	Length (mm)	Finish	Order no.			
	Swivel arms (round)	850	Tubing 27 x 2, high-gloss chrome-plated	00.29 066.10		
	Pat pend. / Design pend. Promotional barrier with notice sign	850	Tubing 27 x 2, high-gloss chrome-plated and white plastic	23.50 102.10		
			Tubing 27 x 2, high-gloss chrome-plated and transparent plastic	23.50 103.10		
Info sign	Dimensions (mm)		Front	Back	Order no.	
	Pat pend. / Design pend. for Swivel arms	400 x 237	Plastic, transparent			23.53 553.07
			White plastic			23.46 079.07
	Pat pend. / Design pend. for Promotional barrier	610 x 242	Plastic, transparent			00.54 389.07
			White plastic			00.67 142.07
Electrical components				Order no.		
	Digital counter – installation kit	Customers counted via direction-sensing radar. Adjustable radar sensitivity enables very precise counting.		23.72 118.10		
	Control panel with counter	Counts customers via direction-sensing radar Digital readout		98.72 914.00		
	Unauthorised exit alarm with MP3 recorded announcement	Allows operator to enable access in passage and exit direction Permanent access is also possible		On request		
	Emergency exit alarm, optical (beacon, dome light)	When the swivel arms are opened towards the exit with the requisite force, as in the case of an emergency, the beacon in the dome light turns on.		00.92 318.95		
	Power supply from above	230 V power supply* and linkage of entrance systems from the ceiling. 1) Ceiling holder, 2) Power supply tube, 3) Covering plate.		23.27 237.10		

\* Warning: the power supply must be installed by specialist personnel.

## 02.03 Ecoport

*The classic entrance system for reducing inventory losses*

- > *Stylish and functional*
- > *High-quality engineering takes care of all safety and security issues*
- > *One- and two-gate versions with lead-through and lead-out sections*



### SINGLE ECOPORT

left-opening, with lead-out section  
Notice sign, transparent plastic

Pat. pend.

### Optional equipment

Emergency exit alarm system,  
Power supply from the ceiling,  
Counter,  
Control panel

**Equipment:** Ecoport column, swivel arms, uprights and connection tubes made from steel tubing. Stable base plates with sheet steel coverings.

**Control unit:** Opening signal via infrared light barrier or radar with range from 0.5 up to 2.5 m.

### Technical equipment:

230 V power supply through conduits in the floor or from the ceiling. Low 24 V operating voltage.

Opening direction to the left or right.

Adjustable opening time from 1 to 16 seconds.



# 02.03 Ecoport

■ **The tried and tested system** with all the important functions you need to make your shop entrance safer.

Single Ecoport (high-gloss chrome-plated)						
without lead-out section			With radar		Order no.	
<b>Operation:</b> - Opening signal controlled by radar. - Gate closes after the set open time. - This function is identical for all systems. 1) Fig.: Single Ecoport, left-opening, basic model, radar control, accessory: notice sign.			Left-opening	23.28 598.10		
			opens towards the right	23.28 597.10		
with lead-out section rear connection tubes 1100 mm			With radar		Order no.	
<b>Operation:</b> see above 2) Fig.: Single Ecoport, right-opening, basic model with lead-out section, radar control, accessory: notice sign.			Left-opening	23.29 178.10		
			opens towards the right	23.29 177.10		
Single Ecoport, two-gate (high-gloss chrome-plated)						
with lead-through and lead-out sections middle / rear connection tubes 1100 mm			with radar and light barrier		Order no.	
<b>Operation:</b> - Ecoport systems open independently from each other. - Opening signal for the first gate controlled by radar. - Opening signal for the second gate triggered by interruption of the light barrier in the first gate. - The gates close after the set open time independently from each other. - This function is identical for all two-gate systems. 3) Fig.: Single Ecoport, two-gate, right-opening, basic model with lead-through and lead-out sections, radar control and light barrier. Accessories: notice sign.			Left-opening	23.38 856.10		
			opens towards the right	23.38 855.10		
Accessories						
<b>Barrier or swivel arm</b>		Barrier length (mm)	Finish			Order no.
	Swivel arms (rectangular)	850	Tubing 27 x 2, high-gloss chrome-plated			00.20 373.10
<b>Info sign</b>		Dimensions (mm)		Front	Back	Order no.
	for Swivel arms	400 x 237	Plastic, transparent			23.53 553.07
			White plastic			23.46 079.07
<b>Electrical components</b>					Order no.	
	Foot switch	The swivel arms open after operating the foot switch.			98.72 775.00	
	Special control panel	For remote control, works automatically with infrared light barrier or radar or manually with control panel. Individual or permanent passage.			98.72 776.00	
	Counter unit	To measure customer frequency. 8-digit LCD display, simple reset with reset button. For Ecoport systems with light barrier in lead-in section only.			98.72 807.00	
	Power supply from above	230 V power supply* and linkage of entrance systems from the ceiling. 1) Ceiling holder, 2) Power supply tube, 3) Covering plate.			23.27 237.10	

\* Warning: the power supply must be installed by specialist personnel.

## 02.04 Checkout Barriers / Swivel Doors

*Customer-friendly entrances and exits*

- > For "two-sided" anti-panic feature: the self-locking S checkout barrier
- > Much-improved security at the checkout
- > Simple and good for both entrances and exits: mechanical swivel doors



**STANDARD S CHECKOUT BARRIER**  
self-locking, on the upright,  
tall configuration



**SWIVEL DOOR**  
mechanical, left-opening

Pat. pend.

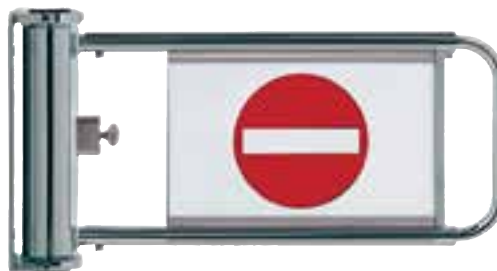

**STANDARD S CHECKOUT BARRIER**  
self-locking, on the flange  
for mounting at the checkout

## 02.04 Checkout Barriers and Swivel Doors

■ **Protection against shoplifting** – especially at unstaffed checkouts – is provided by self-locking checkout barriers, or by reliable mechanical swivel doors.

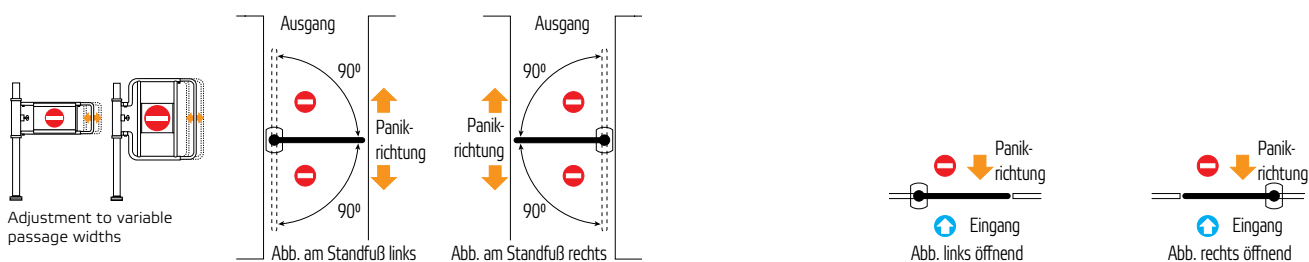

**S checkout barrier - equipment:** Steel tubing base,  $\varnothing$  60 mm, with base plate and base plate cover or flange for mounting on the checkout counter. Steel tubing swivel arms in standard or tall configuration, can be pulled out to fit variable passage widths. Locks automatically at 90° angles, key required to unlock. Panic alarm as standard. Unbreakable plastic notice sign, printed on both sides.  
**Finish:** High-gloss chrome-plated.

**Swivel door, mechanical – equipment:** Steel tubing upright,  $\varnothing$  60 mm, with large base plate. Metal base plate cover for assembly on the floor. Steel tube swivel barrier. Hydraulically controlled locking device for even return motion of barrier. Unbreakable plastic notice sign, printed on both sides.  
**Finish:** High-gloss chrome-plated.

S checkout barrier, self-locking (high-gloss chrome-plated - other finishes on request)					
	Standard configuration		high version		
Designs	<ul style="list-style-type: none"> <li>swivel arms extendible, 530 - 730 mm</li> <li>Notice sign* No-entry symbol, front and back</li> </ul>		<ul style="list-style-type: none"> <li>swivel arms extendible, 530 - 730 mm</li> <li>Notice sign* No-entry symbol, front and back</li> </ul>		
		Order no.	Order no.	Order no.	Order no.
on the upright, two-sided anti-panic feature		23.02 733.10-V001		23.02 735.10-V003	
with flange, two-sided anti-panic feature			23.02 745.10-V001		23.02 747.10-V001
<b>Accessories</b> Fixings for normal floor constructions					
Screw M10 x 60**		90.11 274.50		90.11 274.50	
Dowel M10, PA (Nylon)**		91.07 196.00		91.07 196.00	
Swivel door, mechanical (high-gloss chrome-plated – other finishes on request)					
	Left-opening		opens towards the right		
<ul style="list-style-type: none"> <li>Base plates Metal, rectangular</li> <li>Notice sign* Arrow symbol on front, No-entry symbol on back</li> </ul>					
		Order no.		Order no.	
Swivel door		23.08 723.10-V001		23.08 723.10-V004	
- with deflector roll		23.08 723.10-V002		23.08 723.10-V005	
- with deflector roll and profile		23.08 723.10-V003		23.08 723.10-V006	
<b>Accessories</b> Fixings for normal floor constructions					
Screw M10 x 60**		90.11 274.50		90.11 274.50	
Dowel M10, PA (Nylon)**		91.07 196.00		91.07 196.00	

\* Acrylic glass notice sign on request

\*\* You will need 4 screws and 4 dowels for each upright

## 02.05 Classic Customer Guidance System

*Direct customer flows, increase revenues and prevent inventory losses.*

- > Partition and structure spaces in all situations*
- > Close and open passages in a flexible manner*
- > A clear orientation aid that's a friendly revenue driver*



**CLASSIC CUSTOMER GUIDANCE SYSTEM**

Uprights and connection tubes

# 02.05 Classic Customer Guidance System

■ **Customers respond to orientation aids** – the clearer and friendlier, the better. Boost revenue whilst avoiding inventory losses.

## Attractive colours

**Selected standard colours\*** for plastic connection sleeves and end caps, the chrome-plated finish is metal.



Anthracite grey	RAL 7016	
Light grey	RAL 7035	
Bright chrome	0719	

\* Custom colours available on request.

**Design of uprights:** steel tubing,  $\varnothing$  50 mm, with large base plate. Base plate cover, 110 x 180 mm. Coloured plastic connection sleeves for 40 mm connection tubes. Coloured plastic caps.

**Finish:** High-gloss chrome plated. Coloured plastic powder-coated finishes and stainless steel finishes on request.

**Connection tubes:** Made of steel tubing,  $\varnothing$  40 mm.

Classic customer guidance system (high-gloss chrome-plated)				
Uprights	with: 2 connection sleeves	4 connection sleeves, 180°	4 connection sleeves, 90°	6 connection sleeves in T-arrangement
Base plates, rectangular plastic connection sleeves 				
<b>Order no.</b>	23.10 652.10	23.10 653.10	23.10 655.10	23.10 657.10
<b>Connection tubes</b>	Tube lengths Tube length 500 mm Tube length 1,000 mm Tube length 1,500 mm Tube length 2,000 mm Tube length 2500 mm Tube length 3000 mm			<b>Order no.</b>
				23.04 249.10 23.04 017.10 23.04 018.10 23.04 019.10 23.04 243.10 23.04 020.10
<b>Accessories</b>				<b>Order no.</b>
Fixings for normal floor constructions				
Screw M10 x 60**				90.11 274.50
Dowel M10, PA (Nylon)**				91.07 196.00

\*\* You will need 4 screws and 4 dowels for each upright.

## 02.06 Railix® Partition System

*Partitions with the right perspective*

- › *Customisable partition system*
- › *Easy to assemble, easy to maintain, and protected from damage by bumpers*
- › *The elegant way to reduce inventory losses*

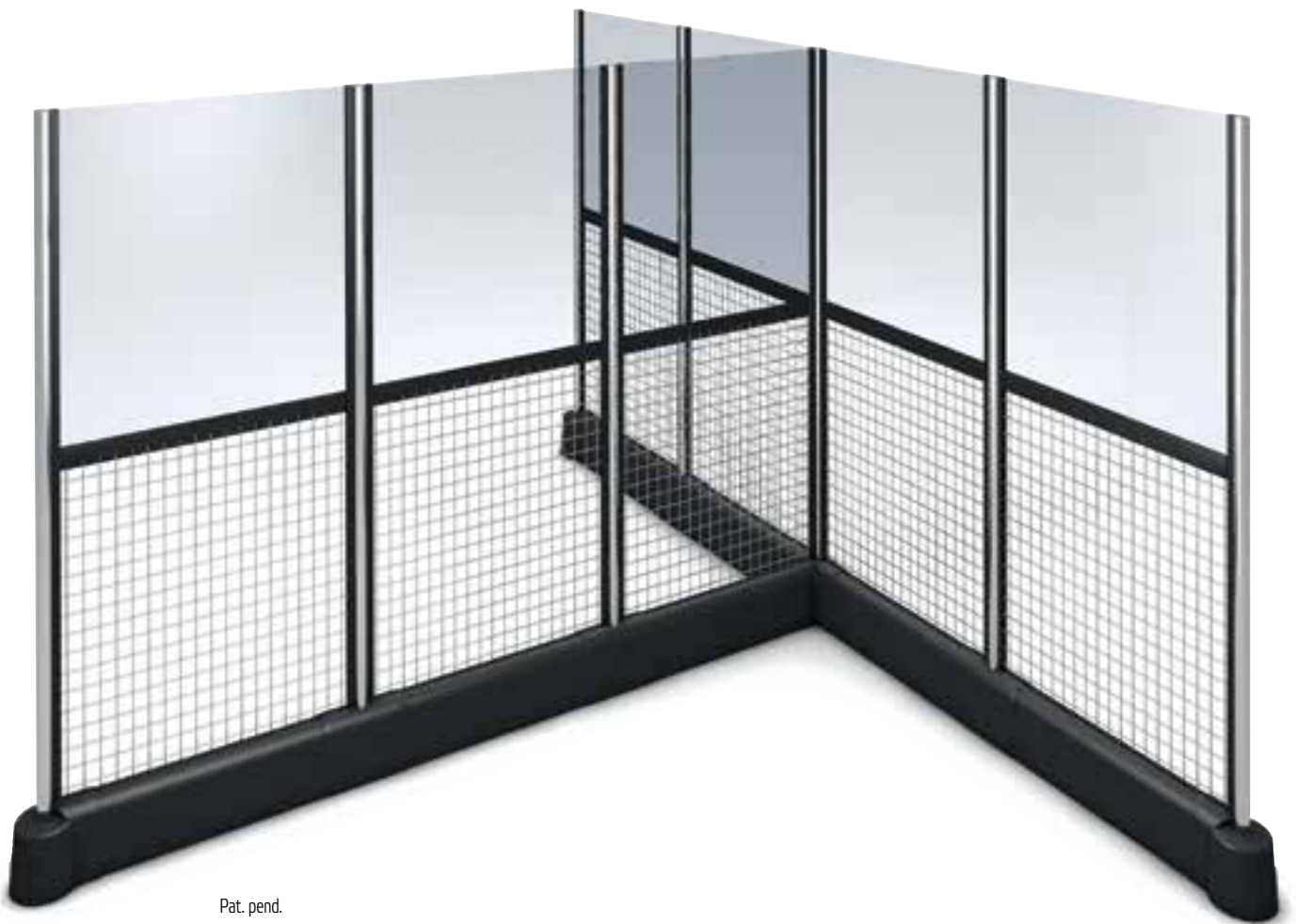

Pat. pend.  
Design pend.

**RAILIX®**  
Partition system

## 02.06 Railix® Partition System

■ **Partitioning perfected** for a wide range of stylish, creative options. Variable partition elements make it easy to implement a host of creative ideas. Available in wood or other materials. Ideal if a specific areas needs to be screened from full view.



Classic 90° solution



Variable angles

### Adaptable for installation in all kinds of situations

#### Separate spaces variably and economically

Corner elements can be assembled freely from 90° to 270°, which makes the system highly adaptable and able to handle any design or necessary change with no difficulty whatsoever.



Meeting room, children's play area, etc.



Versatile wall connections

**Design of uprights:** steel tubing, Ø 50 mm, with large base plate and U snap-in profile, height 2000 mm. Base and corner elements, skirting, snap-in profiles and plastic wall fastenings, finished in Anthracite grey RAL 7016.

#### Partition elements:

- wire Ø 5 mm, mesh width 50 x 50 mm
  - Acrylic glass, Transparent 9095, sheet thickness 6 mm
- Finish:** High-gloss chrome-plated.  
Coloured plastic powder-coated and stainless steel on request.

Railix® (high-gloss chrome-plated)						
Initial / terminal upright	Centre upright, 180°	Corner upright, 90°	T joint upright 2 x 90°	Upright Two connections*	Upright Three connections*	Partition element Wire grate / Acrylic glass
<b>Order no.</b> 23.46 341.10-7016	<b>Order no.</b> 23.46 567.10-7016	<b>Order no.</b> 23.46 906.10-7016	<b>Order no.</b> 23.51 313.10-7016	<b>Order no.</b> 23.47 471.10-7016	<b>Order no.</b> 23.53 686.10-7016	<b>Order no.</b> 23.48 375.95-7016
Initial / terminal base element	Centre base element	Corner base element 90°	T joint base element 2 x 90°	Base element Two connections	Base element 3-fach Anbindung	Skirting
<b>Order no.</b> 23.47 810.07-7016	<b>Order no.</b> 23.51 765.07-7016	<b>Order no.</b> 23.48 940.07-7016	<b>Order no.</b> 23.51 200.07-7016	<b>Order no.</b> 23.47 697.07-7016	<b>Order no.</b> 23.53 912.07-7016	<b>Order no.</b> 23.48 262.95-7016
Accessories						
U snap-in profile for wall mounting, length 1920 mm						23.54 364.95-7016
H snap-in profile for connecting partition elements, length 930 mm						23.14 814.07-7016

Partition elements made entirely of wire or acrylic glass available on request.

\* Variable angles

## 02.07 Bumper Systems

*Designed for shopping trolleys – functional and stylish*

- > Bringing shopping and transport trolleys to a stop before any damage occurs
- > Effective protection for freezer cabinets, store furniture, checkout counters, heaters, etc.
- > The right system for your shop fittings



**BUMPER BARS**  
Bumpers

**Design:** Steel tubing, tube Ø 40 mm. Screwed into steel connection sleeves on the floor.  
**Finish:** High-gloss chrome-plated.



**NX STAINLESS STEEL GUIDE RAIL**  
Bumpers

**Design:** Stainless steel tubing, tube Ø 40 x 2 mm, with bases welded on. Vario aluminium corner connectors. Push-fit connectors and end caps made from black plastic.  
**Finish:** Polished stainless steel.



**TECHNOLINE GUIDE RAIL**  
Bumpers

**Design of guide rails:** Flat oval aluminium profile with rugged clip-on plastic profile available in six standard colours.

**Height-adjustable bases:** Steel tubing with large base plate and base plate cover made of plastic.

**Finish:** Bases high-gloss chrome-plated. Base plate covers and Vario corner connectors in Anthracite grey RAL 7016.



**ProTec 3®**  
Bumpers

Design pend.













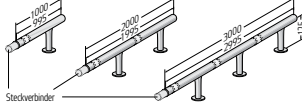
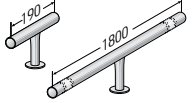

**Design:** Bumper system made of shaped sheet steel. Fasteners, corners and end caps made of black elastomer. Bases made of sheet steel for floor fastening.

**Finish:** Bumper profile galvanised, base galvanised with transparent enamel coating.

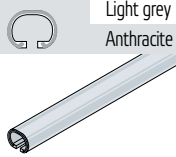
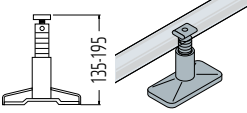
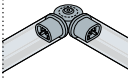
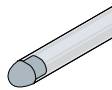
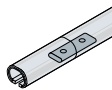
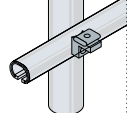
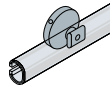
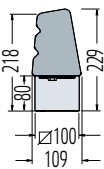

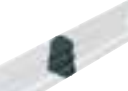
# 02.07 Bumper Systems

■ **Wanzl bumper systems** offer effective protection for freezer cabinets and shop fittings. They reliably protect from shopping or transport trolleys, refill trucks etc, before damage occurs.

Bumper bars* (high-gloss chrome-plated)										
<b>Corner bar</b> incl. screws and dowels		<b>Bars</b> Length 500 mm incl. screws and dowels		Length 1000 mm incl. screws and dowels		Length 1500 mm incl. screws and dowels		<b>Bar connector</b> Length 150 mm, Ø 35.5 mm for constructing interim lengths		
										
Order no. 23.80 392.10		Order no. 23.80 393.10		Order no. 23.80 394.10		Order no. 23.80 395.10		Order no. 00.85 076.09		
NX stainless steel guide rails (high-gloss chrome-plated)										
<b>Connection tube, base arranged asymmetrically</b> 1 m, 1 foot length 995 mm			<b>T-connector, base centred</b> short, 1 foot length 190 mm		<b>Corner</b> 90°		<b>Vario corner connector</b> 90° - 270°	<b>End bow</b>	<b>Push-fit connector</b>	<b>End cap</b>
										
Order no. 23.64 189.09			Order no. 23.64 415.09		Order no. 23.63 511.09		Order no. 23.89 162.73	Order no. 23.77 975.09	Order no. 23.21 244.07	Order no. 01.55 962.07
TechnoLine guide rails										
<b>Guide rail "Oval" **</b> Aluminium profile with plastic profile in 6 colours			<b>Base, height-adjustable</b> Height range 135 - 195 mm, base plate covering in Anthracite grey		<b>Vario corner connector</b> from 90° to 270° Plastic, Anthracite grey		<b>End cap</b> high-gloss chrome-plated	<b>Connection piece</b> high-gloss galvanised, chrome-plated	<b>Angular fastener</b> for upright Aluminium For wall on request	<b>Wall mounting plate</b> high-gloss chrome-plated
										
Order no. 23.69 161.44			Order no. 23.86 622.95-7016		Order no. 23.69 166.07-7016		Order no. 23.69 162.10	Order no. 23.89 388.50	Order no. 23.74 992.44	Order no. 23.74 994.10
ProTec 3 bumper system® (galvanised)										
	<b>Bumpers</b> Profile priced by metre max. length 3 m	<b>End cap</b> Left      Right		<b>Connector</b> 180°	<b>Outer corner</b> 90°	<b>Inner corner</b> 90°	<b>Floor fastening foot</b> Foot      Fixings per base 2 screws      2 dowels			
										
Order no. 23.60 100.50	Order no. 23.60 106.07-9005	Order no. 23.60 107.07-9005	Order no. 23.60 105.07-9005	Order no. 23.60 103.07-9005	Order no. 23.60 104.07-9005	Order no. 23.60 108.51	Order no. 90.11 274.50	Order no. 91.07 196.00		

\* Version with floor sleeves or in stainless steel on request.  
 \*\* Please indicate desired colour and length. Max. length per rail 6 m. Pricing is by the full metre.

# 03 Product overview

## 03.01 – 03.02 Bargain Tables



01 TABLE 8



DESIGN 99



02 P BARGAIN TABLES



PS BARGAIN TABLES

## 03.03 – 03.04 Bargain Baskets



03 BARGAIN BASKETS



GVK SALES BASKETS



04 JOKER DISPLAY



BASKET PRESENTATION STANDS

## 03.05 – 03.07 Promotional Displays for Fruit and Vegetables



05 VARIO FLOWER DISPLAY



06 MOBILO



07 SWING SLOPING DISPLAY



## 03.08 – 03.11 Modular Systems and Displays



08 CUBE®



09 TWINNO®



10 UNIVERSAL



11 AD 100 JOY



AD 200



AD 300

## 03.12 – 03.15 Pallet Sales Systems



12 POSSIBILITY



13 PALETTI

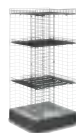

14 POSMODUL 7/7  
(MODULE 2)



15 PALLET BOXES

## 03.16 – 03.19 Stacking Baskets, Shelf Baskets / Insert Baskets, Hang-In Basket Systems



16 KMF STACKING BASKETS



17 KKF STACKING BASKETS



18 SHELF BASKETS / INSERT BASKETS



19 L AND S SERIES HOOK-IN BASKET SYSTEMS

# 03 Presentation



## 03.01 Bargain Tables

*Attractive, plastic powder-coated tables*

- › *Stationary or mobile with brakes*
- › *High-quality table systems specially crafted for appealing product presentation*
- › *Suitable for use with many products in a wide range of sectors*



**TABLE 8**  
mobile



**TABLE 8 K**  
stationary  
with divider

# 03.01 Bargain Tables

■ **Solid base models** for successful retailing. Down-to-earth sales systems born in the field. High quality workmanship with many additional and expansion options.



**DESIGN 99 D 12/8**  
mobile  
with divider

## 8 / 8 K bargain table

**3 easy-care patterns** for table tops, and 2 colours for table corners, legs and frames available.

Table tops	
Pure white	RAL 9010
Salt and Pepper, grey	
Burled	
Table corners, legs and frames	
Pure white	RAL 9010
Light grey 7035	RAL 7035

## Design 99 bargain table

**These space-saving models**, finished in Pure white RAL 9010, can be set up in rows or stacked for storage.



**Design:** Table legs and frame made of square steel tubing, plastic powder-coated. Table tops of scratch-proof PLATAL sheet steel coated with plastic film. Wire side sections with double wire edges, high-gloss chrome-plated, mesh width 30 mm, folds out in 'K' version. Divider high-gloss chrome-plated.

**Mobile version:** with 4 swivel castors, incl. 2 with brakes.

**Equipment:** Table legs and frame made of square steel tubing, plastic powder-coated. Wooden table tops with robust Thermopal coating. Wire side sections with double wire edges, high-gloss chrome-plated, mesh width 30 mm. Divider high-gloss chrome-plated.

**Mobile version:** with reinforcing frame at bottom and 4 swivel castors, incl. 2 with brakes.

Bargain table	Table 8	Table 8 K
	<b>Order no.</b>	<b>Order no.</b>
Stationary	10.32 104.95	10.32 114.95
Mobile	10.32 105.95	10.32 115.95
Castor Ø (mm)	80	80
Weight (kg) stationary/mobile	32/37	42/47
Loading capacity (kg) stationary/mobile	150	150
<b>Accessories</b>	<b>Order no.</b>	<b>Order no.</b>
Divider		
Length 800 mm	27.07 586.10	27.12 361.10
Length 1200 mm	27.04 309.10	27.08 360.10

Design 99 bargain table	
	<b>Order no.</b>
D 12/8 stationary	10.33 206.95
D 12/8 mobile	10.33 207.95
Castor Ø (mm)	80
Weight (kg) stationary/mobile	24/30
Loading capacity (kg) stationary/mobile	150
<b>Accessories</b>	<b>Order no.</b>
Divider for Design 99 D 12/8	
Length 800 mm	27.07 586.10
Length 1200 mm	27.04 309.10

Bottom trays, table top attachments and A4 brochure holders, as well as other table sizes, on request.

## 03.02 Bargain Tables

*High-gloss chrome-plated special offer tables that do it all*

- > *Stationary or mobile*
- > *High-quality table systems crafted for presenting products of all shapes, sizes and quantities*
- > *Flexible for use with height-adjustable bottom trays*



**P 12/8 DUO**  
stationary



**PS 12/8**  
mobile

Pat. pend.

# 03.02 Bargain Tables

■ **Special offer tables made particularly flexible** by adjustable hook-in bottom trays. The PS bargain table is also quickly set up, and can be folded up again just as quickly and stacked to save space.



Pat. pend. **PS BARGAIN TABLE** stacked on hand lift truck

## P and P Duo

### Mobile version

No space lost when arranging in rows.



## PS and PS Duo

### Safe stacking

The stops in the folding mechanism prevent slippage during transport with a hand lift truck.



**Design:** Table legs and frame made of square steel tubing, hook-in wire mesh side sections. Height-adjustable hook-in bottom tray, reinforced with flat plates. P 12/8 Duo bargain tables with 1 divider and 2 adjustable hook-in bottom trays.



**Mobile version:** 4 swivel castors with brakes.



**Finish:** High-gloss chrome plated.

**Equipment:** Table legs and frame made of square steel tubing, wire mesh side sections with locking mechanism. Folding mechanism for compact storage of tables. Height-adjustable hook-in bottom tray, reinforced with flat plates. PS 12/8 Duo bargain tables with 1 divider and 2 adjustable hook-in bottom trays.

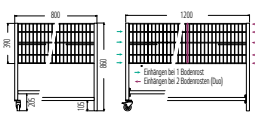
**Mobile version:** 4 swivel castors with brakes.

**Finish:** High-gloss chrome plated.

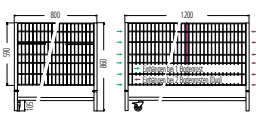
Bargain table	P 12/8	P 12/8 Duo
		
	<b>Order no.</b>	<b>Order no.</b>
Stationary	10.41 815.10	10.05 650.10
Mobile	10.02 599.10	10.50 963.10
Castors Ø (mm)	75	75
Weight (kg) stationary/mobile	27/28	28/29
Loading capacity (kg) stationary/mobile	150	150
<b>Accessories</b>	<b>Order no.</b>	<b>Order no.</b>
Divider		
Length 800 x 180 mm	27.52 796.10	27.52 796.10
Length 800 x 380 mm	27.01 470.10	standard
Length 1200 x 180 mm	27.00 005.10	-

Bargain table	PS 12/8	PS 12/8 Duo
		
	<b>Order no.</b>	<b>Order no.</b>
Stationary	10.47 460.10	10.50 737.10
Mobile	10.55 707.10	10.55 713.10
Castors Ø (mm)	75	75
Weight (kg) stationary/mobile	31/32	32/34
Loading capacity (kg) stationary/mobile	150	150
<b>Accessories</b>	<b>Order no.</b>	<b>Order no.</b>
Divider		
Length 800 x 180 mm	27.52 796.10	27.52 796.10
Length 800 x 380 mm	27.01 470.10	27.01 470.10
Length 800 x 590 mm	27.03 616.10	standard
Length 1200 x 180 mm	27.00 005.10	-

Bottom trays, table top attachments and A4 brochure holders, as well as other table sizes, on request.

# 03.03 Special Offer Baskets

Attractive wire baskets for all sorts of product offerings

- > Variable basket volumes via height-adjustable bottom trays
- > Can be folded quickly and stacked for compact storage.
- > High-quality workmanship

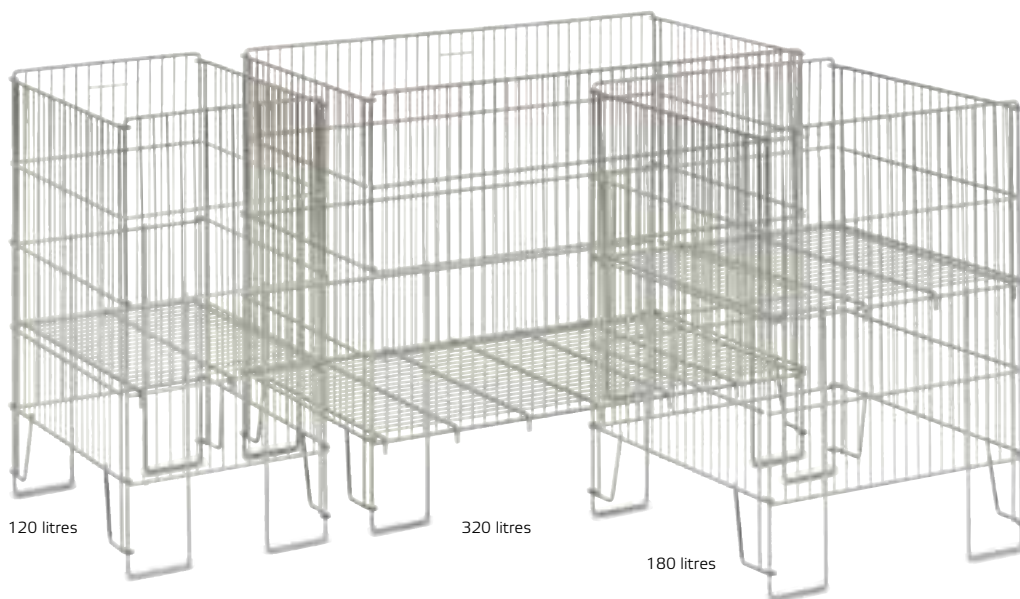

**BARGAIN BASKETS**  
stationary



**GVK 1**  
with mobile chassis

**GVK 2**  
with stationary chassis

**GVK 3**

**GVK SALES BASKETS**  
stationary and mobile



## 03.03 Special Offer Baskets

■ Whether they are rectangular square, round or half moon, they are brilliant for selling bulk items, especially when time is of the essence. Assembled in next to no time.

### Bargain baskets are easily set up



**Design:** Lightweight wire sales baskets, bottom tray height-adjustable to 4 positions. Collapsible for storage and transport.

**Finish:** High-gloss chrome-plated. For the high-gloss galvanised version, please indicate the suffix .50 in your order.

### Poster holder for special offer baskets



Available in 2 sizes for both the bargain baskets and the GVK sales baskets. They are transparent and extendible.

**Design:** Baskets and wire grates. The grates can be hooked in at different heights.

**Finish:** High-gloss chrome-plated.

Bargain baskets	
	<b>Order no.</b>
120 litres	12.03 678.10
180 litres	12.03 679.10
320 litres	12.03 680.10
Castor Ø (mm)	50
Weight (kg) 120/180/320 litres	7/8/12
Loading capacity (kg) 120/180/320 litres	15/20/40
<b>Accessories</b>	<b>Order no.</b>
Poster holder, A4 size	☑
Poster holder, A4 size	☑
Castor set	60.31 602.00

GVK Sales Baskets	GVK 1	GVK 2	GVK 3
	<b>Order no.</b>	<b>Order no.</b>	<b>Order no.</b>
Sales baskets with grate	12.03 662.10	12.03 665.10	12.03 668.10
Weight	5.2	4.6	5.1
Loading capacity (kg)	20	20	20
<b>Accessories</b>			
Chassis, stationary	26.03 664.50	26.03 667.50	26.03 670.50
mobile, 4 castors, Ø 50 mm	26.03 663.50	26.03 666.50	26.03 669.50
Poster holder, A4 size	☑	☑	☑
Poster holder, A3 size	☑	☑	☑

☑ A4 and A3 poster holders available on request.

# 03.04 Special Offer Baskets

*Attractive displays and basket stands for effective product presentation*

- > *Strong presentation of all kinds of product ranges*
- > *The Joker display can hold a top sign*
- > *The basket presentation stand is ideal for special placements, or fresh food.*



**JOKER DISPLAY**  
stationary,  
high-gloss galvanised and chrome-  
plated



**JOKER DISPLAY**  
mobile,  
coloured plastic powder-coated



**BASKET PRESENTATION STANDS**  
Height 450 mm



**BASKET PRESENTATION STANDS**  
Height 650 mm

## 03.04 Special Offer Baskets

### ■ A versatile sales driver for your promotions

- the Joker display, with its clear lines and slim construction, for bulk items and special offers
- the basket presentation stand for items like fresh fruit and vegetables, alcoholic drinks and more.

### Compact

**Folds quickly and extremely flat** to facilitate transport and intermediate storage. Easy for staff to handle.



**Design:** Light wire sales baskets. Adjustable bottom tray for variable use in 3 positions. Quick and easy to assemble and disassemble without tools. Collapsible for compact storage. Mobile versions with 4 swivel castors, incl. 2 with brakes.

**Finish:** high-gloss galvanised and chrome-plated. Coloured plastic powder-coated finish available on request.

### Fresh presentation

**Appealing display** not just for fruit and vegetables, but any food and grocery items to be put in the promotional spotlight.



**Design:** Robust tubular construction, welded. Floor-safe feet with plastic caps.

**Finish:** Plastic powder-coated in Anthracite grey RAL 7016.

**Wicker bulk goods baskets:** Woven wicker baskets with handles made from natural materials. Inserts easily into the tubular structure.

Joker display	
	<b>Order no.</b>
Stationary	12.20 599.50-0000
Mobile	12.20 600.50-0000
Castor Ø (mm)	75
Weight (kg) stationary/mobile	6.8/8
Loading capacity (kg)	50
<b>Accessories</b>	<b>Order no.</b>
Top sign 600 x 400 mm unprinted, incl. plastic clips	12.20 500.07-9010

Basket presentation stands	
	<b>Order no.</b>
Height 450 mm	12.03 843.73
Height 650 mm	12.38 307.73
Castor Ø (mm)	-
Weight (kg)	4.5
Loading capacity (kg)	10
<b>Accessories</b>	<b>Order no.</b>
Wicker bulk goods basket Ø top 500 x Ø bottom 320 x height 300 mm	12.38 194.00

# 03.05 Vario Flower Display

Mobile revenue booster for flowers

- > For cut flowers, potted plants and accessories
- > Compact dimensions
- > Ideal for indoor and outdoor presentation



**VARIO FLOWER DISPLAY**  
with six bucket holders

Pat. pend.

## Extra shelf

**Folds out conveniently** when an additional shelf is needed for watering cans, vases or flower pots.



**Design:** Robust wire construction with six bucket holders and three fold-out extra shelves.

**Finish:** High-gloss galvanised and chrome-plated.

**Castors:** 4 swivel castors, incl. 2 with brake.

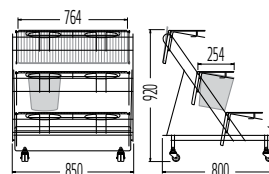

## Vario flower display



	Order no.
Mobile	12.29 606.50
Castor Ø (mm)	50
Weight (kg)	22
Loading capacity (kg) per shelf / total	15/50
<b>Accessories</b>	
Plastic bucket, black, 10 litres	12.20 249.07

# 03.06 Mobilo

Mobile revenue booster for fruit and vegetables

- > Presentation unit, also suitable for other product offerings
- > Movable, inclination of support surfaces adjustable to 7 different angles
- > Ideal for indoor and outdoor presentation



**MOBILO**  
High-gloss, galvanised,  
chrome-plated



**MOBILO - 3 IN A ROW**  
plastic powder-coated, black

## Compact

### Assembly and disassembly:

Folds easily and without tools for transport and storage.



**Design:** Rack made of steel tubing. Can be extended to the front and back and variably adjusted in height and inclination. Support surface with anti-slip guard.

**Finish:** High-gloss galvanised and chrome-plated.

**Castors:** 2 fixed castors.

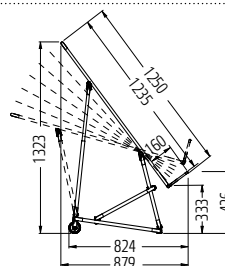

## Mobilo



	Order no.
High-gloss, galvanised, chrome-plated	12.41 019.50
Plastic powder-coated, colour on request.	12.41 019.73
Castor Ø (mm)	80
Weight (kg)	16
Loading capacity (kg)	150
Mobilo, folded W x D x H (mm)	600 x 1981 x 172

# 03.07 Swing Sloping Display

*Flexible and always up to date*

- > *With wire or wooden rack*
- > *Movable, inclination of support surfaces adjustable to 5 different angles*
- > *With practical accessories*



Extra shelf with wooden slats

Wooden slat shelf

## SWING

Swing sloping display with wooden slats



Extra level with wire rack

Wire rack shelf

## SWING

Swing sloping display with wire rack

## 03.07 Swing Sloping Display

### Mobile, clear and extremely practical

With adjustable display sections, matching accessories such as an extra shelf, sign holder and adjustable hook-in tray retaining bars. Different versions to suit a wide range of requirements.

**Also available:  
Swing display stand**

### A smaller companion to the swing sloping display

Quick and easy to set up, can be used anywhere, and the castors make it very mobile. A robust, weather-proof multi-purpose money spinner.



**Equipment:** Robust chassis construction. Display section can be safely locked horizontally and in 5 inclined positions. 4 swivel castors, incl. 2 with brake.

**Swing sloping display with wire rack:** Angled contoured tubular frame with flush-welded wire grate sections.

**Swing sloping display with wooden slats:** Contoured tubular frame with bolted beech multiplex slats (with transparent

organic varnish) and steel profiles. Angled section can be folded. **Finish:** High-gloss galvanised and chrome-plated. Coloured plastic powder-coated chassis available on request.

**Accessory awning:** Height-adjustable tubular construction with folding awning frame, high-gloss galvanised and chrome-plated. Awning fabric made of non-fading acrylic fibre, impregnated for water and dirt resistance, in blue or orange-white.

Swing sloping display				
	with wire rack		with wooden slats	
Axis dimension	1650		1650	
		<b>Order no.</b>		<b>Order no.</b>
		12.04 973.50		12.24 521.50
Castor Ø (mm)		125		125
Weight (kg)		56		59
Loading capacity (kg)		150		150
<b>Accessories</b>				
Extra shelf	with wire rack	12.66 059.50	with wooden slats	12.24 522.50
Width x depth (mm)	1600 x 490		1615/2000 x 450	
Retaining bars, hook-in, width (mm)	370	10.47 715.50	275	10.11 413.50
Display section	wire grate	12.14 351.50	with wooden slats	12.14 464.50
Width x depth (mm)	1593 x 644		1520 x 644	
Awning, blue		12.21 811.50		12.21 811.50
Awning, orange-white		12.19 549.50		12.19 549.50

Baskets, sign holders and A4 poster frames available on request.

# 03.08 Cube®

Total planning freedom with stylish modules

- > Intelligent modular planning system
- > Effective presentation space for product offerings of all kinds
- > Offers flexibility and can be readily customised for all room dimensions



CUBE®  
modular system



CUBE®  
with plastic  
trays

**Design:** The system comprises stackable square and triangular modules edged with aluminium profiles and studs for stacking.

Wire or acrylic glass edging. Standard base inlays plastic powder-coated, Grey Aluminium RAL 9007. Other colours and finishes available on request.

## Easy to set up, easy to assemble

- Wire edging
- Base inlays
- Module
- Front panel
- Acrylic glass edging
- Base inlays
- Module

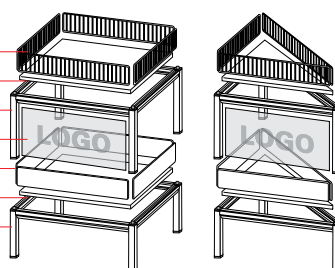

Assembled in a flash:  
version with mobile module.



# 03.08 Cube®

■ In both food as well as non-food sections, this highly flexible modular planning system creates effective presentation space for all room dimensions.



CUBE®  
with accessories

Cube®		Loading capacity for each single table 35 kg					
<b>Side lengths</b>		<b>585 mm</b>			<b>785 mm</b>		
<b>Module shapes</b>		<b>square</b>	<b>triangular</b>		<b>square</b>	<b>triangular</b>	
Dimensions, width x depth (mm)		585 x 585	585 x 585 x 825		785 x 785	785 x 785 x 1109	
<b>Modules, stationary</b> with legs							
<b>Height (mm)</b>		<b>Order no.</b>	<b>Order no.</b>		<b>Order no.</b>	<b>Order no.</b>	
<b>200</b>		12.11 419.95	12.11 428.95		12.11 416.95	12.11 425.95	
<b>300</b>		12.11 418.95	12.11 427.95		12.11 415.95	12.11 424.95	
<b>400</b>		12.11 417.95	12.11 426.95		12.11 414.95	12.11 423.95	
<b>Modules, mobile</b> with 3 or 4 swivel castors, castor Ø 75 mm, each incl. 2 with brakes, height 135 mm. Warning – for 200 mm module heights only.							
		00.13 297.73	00.24 833.73		00.13 071.73	00.25 398.73	
<b>Base inlays</b>							
Sheet metal base, Platal, burled silver finish		00.12 619.77-9074	00.20 416.77-9074		00.12 393.77-9074	00.20 303.77-9074	
Wooden base, white		00.26 415.78	00.26 754.78		00.27 319.78	00.27 432.78	
Wooden base, alder pattern		00.11 489.78	00.20 981.78		00.11 150.78	00.20 868.78	
Wired glass base		00.12 167.00	00.22 224.00		00.11 941.00	00.21 320.00	
<b>Plastic tray</b>							
Plastic tray		00.55 325.07.0000	-		00.55 326.07.0000	-	
Plastic tray with felt lining		00.98 953.07.0000	-		00.99 292.07.0000	-	
<b>Edging</b>			for side length			for side length	
Wire, high-gloss chrome-plated, height 91 mm, 1 unit		00.08 325.10	585	00.08 325.10	00.07 082.10	785	00.07 082.10
			825	00.09 116.10		1109	00.09 455.10
Wire, high-gloss chrome-plated height 170 mm, 1 unit		00.08 551.10	585	00.08 551.10	00.07 534.10	785	00.07 534.10
			825	00.09 229.10		1109	00.09 568.10
Acrylic glass, transparent height 97 mm, 1 unit		00.09 681.07	585	00.09 681.07	00.07 760.07	785	00.07 760.07
			825	00.09 794.07		1109	00.10 359.07
Acrylic glass, transparent height 226 mm, 1 unit		00.27 545.07	585	00.27 545.07	00.27 997.07	785	00.27 997.07
			825	00.27 771.07		1109	00.28 336.07
<b>Front panel</b>			for side length			for side length	
Height (mm) 200		00.15 218.07	585	00.15 218.07	00.14 314.07	785	00.14 314.07
			825	00.15 896.07		1109	00.16 348.07
Height (mm) 300		00.14 540.07	585	00.14 540.07	00.13 749.07	785	00.13 749.07
			825	00.15 670.07		1109	00.16 235.07
Height (mm) 400		00.14 427.07	585	00.14 427.07	00.13 636.07	785	00.13 636.07
			825	00.15 557.07		1109	00.16 122.07
<b>Accessories</b>							
Clip-on frame height 1200 mm, 1 unit		Width 585 x height 1200 mm	00.28 449.73		Width 785 x height 1200 mm	00.28 562.73	
Sign for clip-on frame PVC, white, 3 mm		Width 520 x 1220 mm	00.30 257.07		Width 720 x height 1220 mm	00.31 952.07	
Wire shelf Depth 250 mm		Width 585 x depth 250 mm	00.28 675.73		Width 785 x depth 250 mm	00.29 466.73	
Scannable price rail, convex, transparent, length 80 mm x height 40 mm			21.72 772.07			21.72 772.07	

# 03.09 Twinn®

*Cool-looking modular display*

- > Flexible selling options
- > Variable use: from single display to shop-within-a-shop system
- > Eye-catching focal point



**TWINN®**  
single-sided



**TWINN®**  
double-sided with rear panel  
extension and top sign

# 03.09 Twinn®

■ **Stylish display** characterised by simple elegance, precision workmanship, high-quality material and extraordinarily versatility.

## Highly versatile

**From standalone display to shop-within-a-shop system:** With its modular structure, it can be deployed as one perfectly designed unit or as a complete solution for a space.



**Design:** Rear panel made of rectangular profiles and wire grate, rear panel extension made of insertable square tubing and wire grate (optional). Left and right side sections with curved flat steel, screwed. Wire shelves. Easy assembly without tools. Mobile versions.

**Castors:** Swivel castors with brakes Ø 50 mm.

**Finishes:** High-gloss chrome-plated or plastic powder-coated in Titanium 7084.

## Top sign

**Semi-circular:**

incl. plastic clips for attachment to the rear panel extension. Printed to order on request.



Twinn®		single-sided	double-sided
<b>Chassis, mobile</b>			
With 3 wire shelves, high-gloss chrome-plated With 3 wire shelves, plastic powder-coated, Titanium RAL 7084		<b>Order no.</b> 12.28 929.10-0000 12.28 929.73-7084	<b>Order no.</b> 12.29 043.10-0000 12.29 043.73-7084
<b>Dimensions (mm)</b>			
Chassis without top sign, width x depth x height (mm)		626 x 525 x 975	626 x 1025 x 975
Shelves, width x depth (mm)		540 x 480 / 430 / 280	540 x 480 / 430 / 280
Loading capacity (kg)		50	100
<b>Accessories</b>			
	Rear panel extension height 422 mm, high-gloss chrome-plated	12.29 155.10-0000	12.29 155.10-0000
	Rear panel extension height 422 mm, plastic powder-coated, Titanium RAL 7084	12.29 155.73-7084	12.29 155.73-7084
	Top sign, semi-circular, unprinted, incl. 2 plastic clips	00.95 729.07-9010	00.95 729.07-9010
	Scannable price rail, Light Grey RAL 7035, width 530 x height 40 mm	21.03 052.07-7035	21.03 052.07-7035
	Blister pack double hook, length 200 mm	24.06 103.50-0000	24.06 103.50-0000
	Blister pack double hook, length 250 mm	24.06 102.50-0000	24.06 102.50-0000

## 03.10 Universal

*More scope for effective merchandising*

- › *Designs with an extensive range of accessories*
- › *Single-sided and double-sided, mobile or stationary*
- › *Product presentation with optional panels for your Corporate Identity*

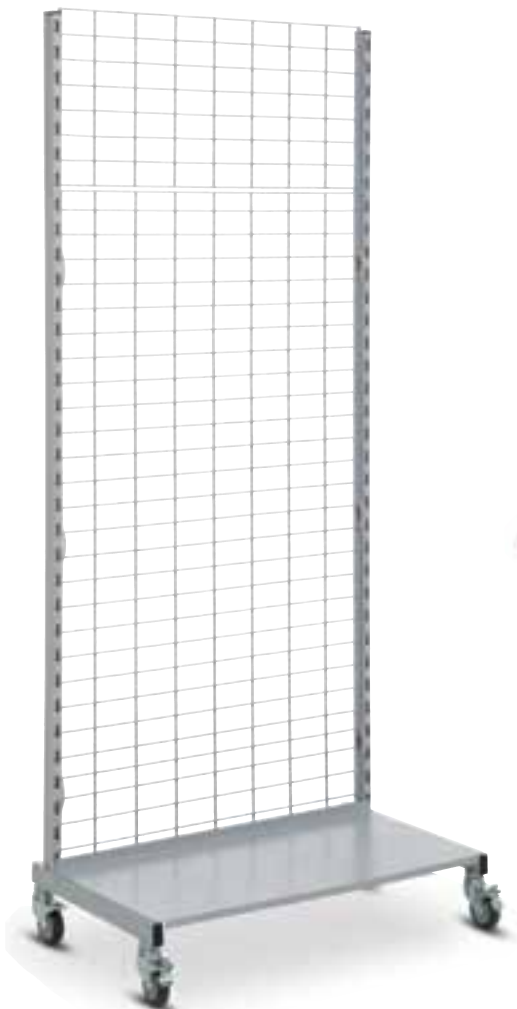

**UNIVERSAL**  
Chassis, single-sided, mobile

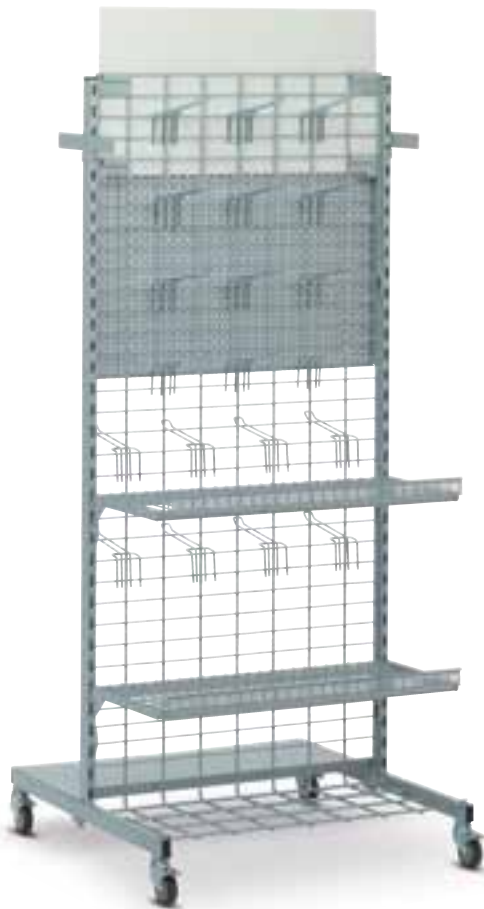

**UNIVERSAL**  
Double-sided, mobile chassis with wire shelves, rear panel made of perforated sheet metal, top sign and blister pack double hooks

# 03.10 Universal

■ **Whether you are looking for unity or variety,** the Universal display is all about greater product variety in the same amount of space and more sales in the same unit area.

**Equipment:** 2 L-shaped side sections made of square tubing. Wire grate rear panel, can be assembled with connectors, no tools needed.  
**Castors:** 4 swivel castors Ø 50 mm, 2 with brakes.  
**Finishes:** High-gloss chrome-plated or plastic powder-coated in Titanium 7084.  
**Optional:** Diverse accessories.

## Side panel set

**Advertising space on all sides:** enhances sales in line with your product designs. Printing available on request.



Universal	
<b>Basic fixture</b>	single-sided
<b>Dimensions (mm)</b>	
Chassis, single-sided, mobile, without top sign, W x D x H (mm)	846 x 545 x 1500
Chassis, single-sided, stationary, without top sign, W x D x H (mm)	846 x 545 x 1420
Chassis with base extension for double-sided version, without top sign, W x D x H (mm)	846 x 960 x 1500
Base cover, W x H	800 x 445
Rear panel extension, W x H	820 x 367
Rear panel made of perforated sheet metal, W x H	800 x 500
Wire shelf, W x H	800 x 365
Sheet metal shelf, W x H	800 x 350
Top sign, W x H	800 x 300
Loading capacity (kg)	120

		Order no.
Chassis, mobile		12.01 133.73-7084
Chassis, stationary		12.01 134.73-7084
<b>Accessories</b>		
	Base extension (double-sided), mobile and stationary	12.01 135.73-7084
	Base cover, metal sheet	12.01 137.73-7084
	Rear panel extension insertable	12.01 138.73-7084
	Rear panel made of perforated sheet metal hooks into the column grating	12.97 633.73-7084
	Wire shelf with raised edge on one side, H 40 mm hooks in level or inclined	12.01 139.73-7084
	Sheet metal shelf with inclined raised edge on one side, H 40 mm, hooks in level or inclined	12.01 140.73-7084
	Scannable price rail for wire shelf, W 770 x H 40 mm, transparent 9095	21.29 833.07-9095
	Scannable price rail for sheet metal shelf, self-adhesive, W 770 x H 40 mm, White RAL 9010	21.29 834.07-9010
	Divider, fits wire shelves with raised edge	27.02 939.73-7084
	Blister pack double hook, L 150 mm	24.02 375.50-0000
	Blister pack double hook, L 300 mm	24.02 374.50-0000
	Top sign, rectangular, white plastic, unprinted incl. 2 fastening clips	12.01 141.07-9010
	Fastener set for decorative rear panel for variable insertion into the rear panel grille	12.01 142.73-7084
	Holder pair for side panels, single-sided version	77.41 996.73-7084
	Holder pair for side panels, double-sided version	77.41 995.73-7084
	Side panel set, white plastic, unprinted W 417 x H 1720 mm	77.41 997.07-0000
	Decorative rear panel, white plastic, unprinted	On request

# 03.11 AD 100 Joy, AD 200, AD 300

AD special offer displays – marvels in time and space

- > Quickly assembled at POS without tools
- > Easily folded to await the next special offer
- > Flexible, mobile and strong



**AD 100 JOY**  
chassis  
incl. 4 wire shelves

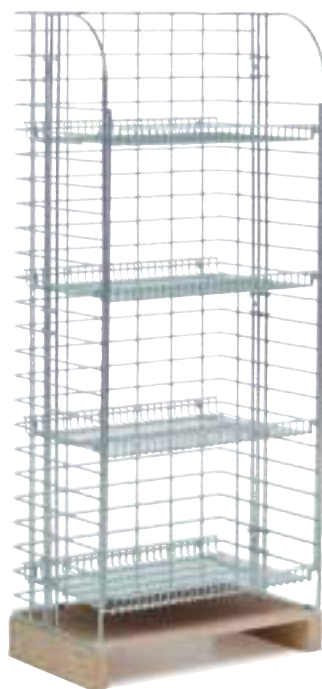

**AD 200 6/4**  
chassis with accessories:  
4 wire shelves

Space required:  
1/4 or 1/2  
Euro pallet



**AD 300 D**  
mobile, chassis with accessories:  
3 wire shelves

**Design:** 4 wire shelves firmly anchored to the square tubing frame can be arranged horizontally or at an incline between the curved side sections. Display is completely collapsible.

**Finish:** Plastic powder-coated in Titanium 7084.

**Design:** Solid, yet collapsible wire construction. Variable-use straight or inclined hook-in wire shelves Easy to move with optional wooden pallet.

**Finish:** High-gloss galvanised and chrome-plated. Coloured plastic powder-coated finish available on request.

**Design:** Chassis made of square tubing with welded wire grate base. Side sections: AD 300 D made of wire, AD 300 R made of square tubing with wire grate. Back section made of wire grate. Can be assembled completely without tools. Adjustable wire shelves.

Stationary: 4 adjustable feet  
Mobile: 4 swivel castors, 2 with brakes.

**Finish:** High-gloss galvanised and chrome-plated. Coloured plastic powder-coated finish available on request.

# 03.11 AD 100 Joy, AD 200, AD 300

■ **The day-to-day needs of retail staff** are well known to Wanzl as a partner to the retail industry. That is why we developed collapsible, space-saving special offer displays for successful product presentation.

**Quick assembly:**  
Fold open, lower shelves, done. Blister pack hooks can be attached to vertically positioned shelves.



Promotion displays	AD 100 Joy	AD 200		AD 300	
	<b>Order no.</b>	<b>Order no.</b>	<b>Order no.</b>	<b>Order no.</b>	<b>Order no.</b>
Stationary	12.50 737.73-7084 (incl. 4 wire shelves)	12.67 236.50-0000	12.50 860.50-0000	06.03 053.50-0000	06.03 054.50-0000
For pallet size (mm)	-	600 x 400	800 x 600	-	-
Mobile	-	-	-	06.03 052.50-0000	06.03 055.50-0000
Weight (kg)	36	10	10	24/26	28/30
Loading capacity (kg)	160	50	50	150	150
<b>Accessories</b>					
Wooden pallet, incl. fixings	-	77.06 359.95-0000	77.06 358.95-0000	-	-
Wire shelf	-	12.67 237.50-0000	12.06 133.50-0000	28.01 244.50-0000	28.01 244.50-0000
Divider for wire shelves	-	27.15 708.50-0000	27.15 595.50-0000	-	-
for top	27.08 927.73-7084	-	-	-	-
for bottom	27.08 814.73-7084	-	-	-	-
Top sign, semi-circular					
unprinted, includes fixings	-	77.06 585.07-9010	77.06 472.07-9010	00.22 219.95-0000	00.22 219.95-0000
unprinted	00.36 841.07-9010	-	-	-	-
Top sign holder	21.39 211.73-7084	-	-	-	-
Blister hooks	Single hooks	Double hook	Double hook	Double hook	Double hook
Length 150 mm	-	24.02 375.50-0000	24.02 375.50-0000	-	-
Length 200 mm	24.06 328.73-7084	-	-	24.01 018.50-0000	24.01 018.50-0000
Length 250 mm	24.06 441.73-7084	-	-	-	-
Length 300 mm	-	24.02 374.50-0000	24.02 374.50-0000	-	-

# 03.12 Possibility

The ultimate revenue driver at the point of sale

- > Presenting 1000 possibilities on Wanzl's metal pallet system
- > 5 attachment positions for side walls allow for a host of ground plan variants
- > Space requirement: 1 Euro pallet



**POSSibility**  
assembled according to  
example C  
with accessories

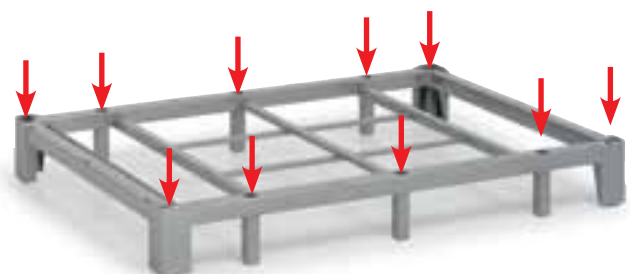

**5 ATTACHMENT POSITIONS**  
for side walls allow for a host of ground plan variants.

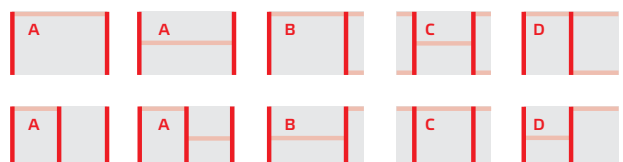
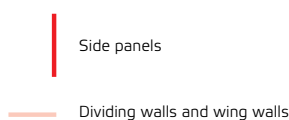



# 03.12 Possibility

**Possibility has been specially designed for impulse buys and special offer placement.** The smart Wanzl metal pallet system in Euro dimensions combines with wire and tubing elements to make up this extraordinarily versatile sales system.

## Side panels and crowners

**Perfect branding** enhances sales in line with your product designs. Printing available on request.

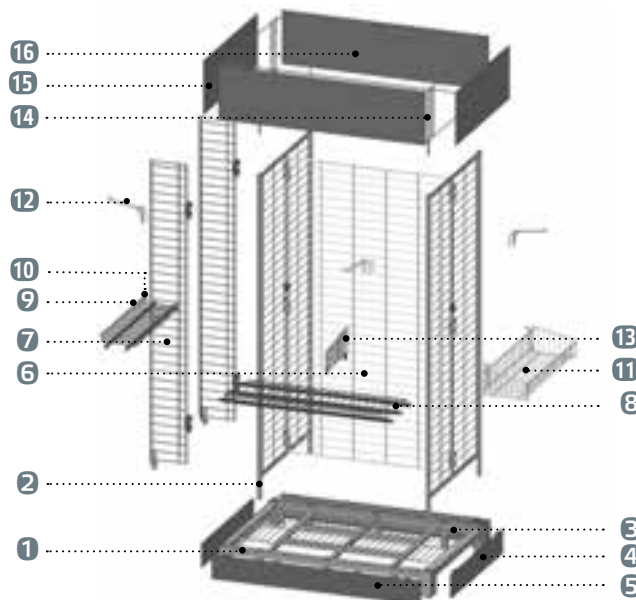

Possibility Loading capacity 500 kg	
<b>Basic module</b> W 1200 x D 800 x H 1850 mm 	
<b>Equipment for metal pallet</b>	
Grate pallet insert	3 28.18 194.73-7084
Pallet insert, wooden panel, coated grey	12.69 609.78-0000
Pallet cover 800, metal coated,	4 12.92 809.73-7084
Pallet lining 1200, coated metal	5 12.92 696.73-7084
Pallet lining 800, white plastic	12.11 664.07-0000
Pallet lining 1200, white plastic	12.11 663.07-0000
<b>Side wall</b>	
Side wall 800	2 12.69 383.73-7084
<b>Dividing walls</b>	
Dividing wall 600, can also be used as a rear panel	12.11 645.73-7084
Dividing wall 800, can also be used as a rear panel	12.11 646.73-7084
Dividing wall 1000, can also be used as a rear panel	12.11 647.73-7084
Dividing wall 1200, can also be used as a rear panel	12.11 648.73-7084
<b>Wing walls</b>	
Wing wall 200, left	12.11 761.73-7084
Wing wall 200, right	12.11 760.73-7084
Wing wall 600, left	12.11 763.73-7084
Wing wall 600, right	12.11 762.73-7084
<b>Wire shelves (assembled between side walls)</b>	
Wire shelf 600, single-sided raised edge 40 mm	12.11 754.73-7084
Wire shelf 800, single-sided raised edge 40 mm	12.11 755.73-7084
Wire shelf 1000, single-sided raised edge 40 mm	12.11 756.73-7084
Wire shelf 1200, single-sided raised edge 40 mm	12.11 757.73-7084

**Equipment:** Base module of metal pallet and 2 side walls. Metal pallet system made of square tubing, side walls made of round tubing frame with wire grate. Quick to assemble and disassemble, compact storage.

**Dimensions (mm):** W 1200 x D 800 x H 1850 (with crowner H 2150).

**Finishes:** All elements made of metal, plastic powder-coated in Titanium Grey RAL 7084.

	Order no.
<b>Wing wire shelves (assembled between wing walls)</b>	
for wing walls 200, single-sided raised edge 40 mm	12.11 658.73-7084
for wing walls 600, single-sided raised edge 40 mm	12.11 659.73-7084
<b>Scannable price rails, transparent</b>	
for wire shelf 600	21.06 556.07-9095
for wire shelf 800	21.06 557.07-9095
for wire shelf 1000	21.06 558.07-9095
for wire shelf 1200	21.06 559.07-9095
for wing wire shelves	21.21 245.07-9095
<b>Accessories</b>	
Side basket, rectangular	11 12.69 496.73-7084
Blister pack double hook 150 mm	12 24.02 375.50-0000
Blister pack double hook 300 mm	24.02 374.50-0000
Divider, inclined, for wire shelves	13 27.02 939.73-7084
Divider, inclined, for wing wire shelves 200	27.02 940.73-7084
Panel for wing wall, white plastic	12.11 662.07-0000
<b>Crowners (can be inserted only in side walls)</b>	
Insertion connector for ground plan A	12.11 651.73-7084
Insertion connector for ground plan B	14 12.11 653.73-7084
Insertion connector for ground plan C	12.11 652.73-7084
Insertion connector for ground plan D	12.11 654.73-7084
Crowner 800, white plastic	15 12.11 661.07-0000
Crowner 1200, white plastic	16 12.11 660.07-0000

For further information please request our detailed brochure. One of our specialists will also be happy to contact you.

## 03.13 Paletti

*Presentation of goods on Euro pallet*

- › *Faster, simpler – more success for less!*
- › *Perfect presentations with an extensive range of accessories*
- › *Space requirement: 1 Euro pallet*



**PALETTI**  
chassis on pallet  
with 4 wire shelves,  
roof and pallet lining

# 03.13 Paletti

■ A totally ordinary Euro pallet forms the basis and is combined with wire elements to create this extraordinary sales system.



**PALETTI**  
quick to assemble and disassemble, collapsible to save space.



**PALETTI**  
sample construction, with fixed centre wall

## Extensive range of accessories

For your every design wish e.g. hook-in side baskets of different designs, blister pack hooks, arms for hanging items, etc.



**Equipment:** Chassis (side sections and centre wall) made of sturdy wire, collapsible, screws into a Euro pallet.

**Dimensions (mm):**

W 1200 x D 800 x H 1650 (with roof 1770).

**Finishes:** High-gloss galvanised and chrome-plated. Coloured plastic powder-coated finish available on request.

**Extensive range of accessories:** see table at right.

**Paletti** Loading capacity 240 kg / max. per shelf 40 kg

Paletti with accessories

	Order no.
<b>Basic fixture</b>	12.11 866.50-0000
<b>Accessories</b>	
<b>Roof</b> with plug-in holders, 3 mm Forex sheet, white	12.11 979.50-0000
<b>Top sign</b> rectangular, 1000 x 350 mm, white	00.35 445.07-9010
<b>Wire shelves</b>	
- 1129 x 356 mm, single-sided raised edge 60 mm	28.04 069.50-0000
- 1129 x 351 mm, double-sided raised edge 150 mm	28.04 295.50-0000
- 1129 x 363 mm, with transparent double layer webbed panel	28.04 182.50-0000
- 1129 x 356 mm, without raised edge	28.04 634.50-0000
- Inlay sheet, transparent, 1129 x 340, for wire shelves	00.85 165.07-9095
- Divider, inclined, fits 28.04 295.50	27.02 939.50-0000
- Front grate, fits 28.04 069.50 and 28.04 634.50	29.01 018.50-0000
- Dividing rod, fits 28.04 295.50	27.03 052.09-0000
<b>Side baskets</b>	
rectangular, 800 x 250 x 150 (height at front) mm	12.12 431.50-0000
half-round, 800 x 250 x 150 (height at front) mm	12.12 092.50-0000
<b>Scannable price rails</b>	
1130 x 40 mm, transparent, fits 28.04 069.50, 28.04 295.50 and 29.01 018.50	21.06 555.07-9095
1130 x 40 mm, transparent, fits 28.04 182.50	21.06 442.07-9095
780 x 40 mm, transparent, fits 12.12 431.50	21.06 329.07-9095
<b>Textile rod</b> , flat oval tubing 30 x 15 x 1200 mm	00.14 319.50-0000
<b>Support arm</b> , round tubing, for hanging items, length 280 mm	24.01 357.50-0000
<b>Blister pack double hook</b>	
200 mm	24.00 679.50-0000
250 mm	24.01 131.50-0000
<b>Pallet lining</b>	
1165 mm	00.34 993.50-0000
805 mm	00.33 976.50-0000

For further information please request our detailed brochure. One of our specialists will also be happy to contact you.

## 03.14 POSmodul 7/7 (Module 2)

*Pallet display with pizzazz*

- › Economical, highly effective display format
- › Draws attention with printable panels for advertising or other messages
- › Removable basket attachment for additional placement options

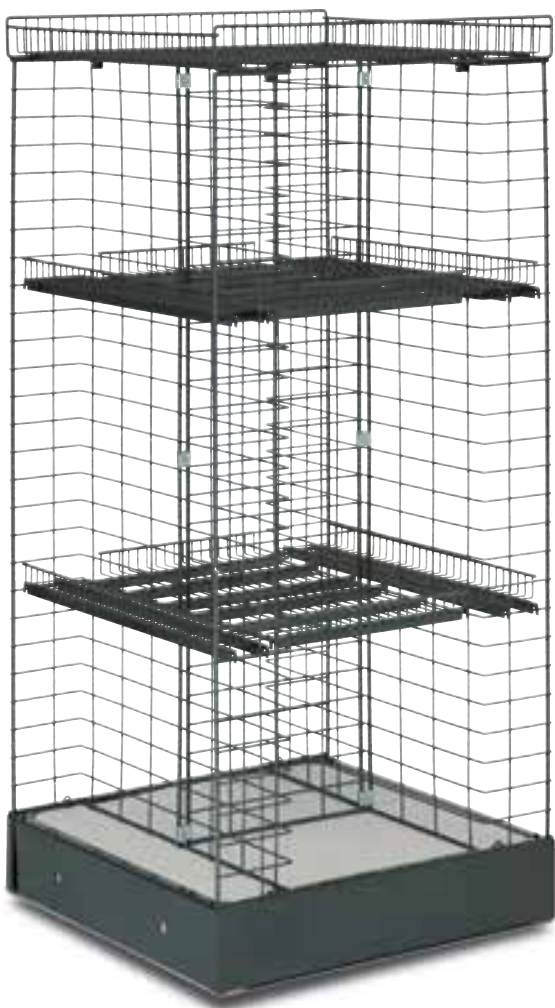

**POSMODUL 7/7 (MODULE 2)**  
chassis with lined wooden pallet, cover plate,  
basket attachment and wire shelves

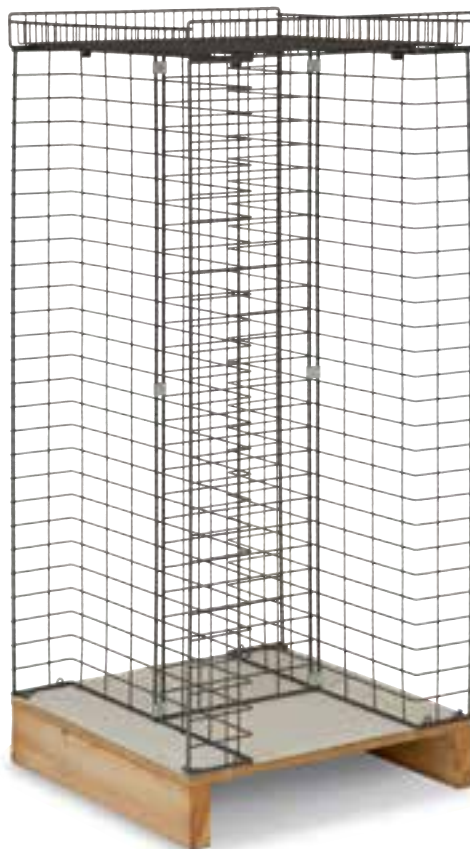

**POSMODUL 7/7 (MODULE 2)**  
chassis with wooden pallet, cover plate and  
basket attachment

# 03.14 POSmodul 7/7 (Module 2)

## ■ POSmodul 7/7 (Module 2)

Display structure enables presentation of any combination of standing items and blister packs.



### Printed side panels

**Draw attention** to and effectively set the scene for your products. Printing available on request.

### Blister pack double hooks

**For variable positioning**  
Blister pack hooks in two lengths: 100 and 300 mm.



### Basket attachment, removable

**For additional placement options**, a practical addition that pays.



**Design:** Chassis (side sections and centre wall) made of sturdy wire, screws into a wooden pallet.

**Optional:** Cover plate and all panels in white plastic, unprinted.

**Dimensions (mm):** W 700 x D 700 x H 1500 (with basket attachment 1575).

**Finishes:** Coloured plastic powder coating in Jet black, RAL 9005.

### POSmodul 7/7 (Module 2) Loading capacity 200 kg / max. per shelf 20 kg

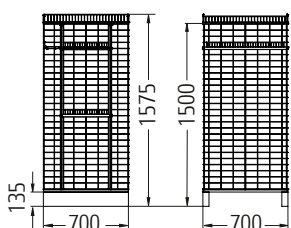
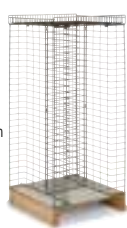

Fig.: POSmodul 7/7 (Module 2) with accessories: wooden pallet, cover plate and basket attachment



	Order no.
<b>Chassis</b> side sections and centre wall	12.01 362.73-9005
<b>Accessories</b>	
<b>Wooden pallet</b> W 700 x D 700 mm	77.10 384.78-0000
<b>Cover plate</b> for wooden pallet W 700 x D 700 mm, white, unprinted	12.97 294.07-0000
<b>Pallet lining set</b> unprinted	12.01 701.73-9005
<b>Attachment basket</b>	12.01 475.73-9005
<b>Wire shelf</b> for centre section with raised edge on one side, H 40 mm	12.01 589.73-9005
<b>Wire shelf</b> for outside sections with raised edge on one side, H 40 mm	12.01 588.73-9005
<b>Scannable price rail</b> W 347 x H 40 mm, transparent, for middle shelf	21.30 624.07-9095
<b>Scannable price rail</b> W 637 x H 40 mm, transparent, for outside sections	21.30 511.07-9095
<b>Side panel</b> W 155 x H 1350 mm, white, unprinted	12.01 814.07-0000
<b>Blister pack double hooks</b>	
Length 100 mm	24.09 832.50-0000
Length 300 mm	24.09 833.50-0000

For further information please request our detailed brochure. One of our specialists will also be happy to contact you.

# 03.15 Pallet Boxes

For versatile use of standard Euro pallets

- > Stackable and non-stackable versions
- > Interesting details include dividers, stacking corners, intermediate grate and basket attachment
- > Space requirement: 1 Euro pallet



<b>wanzl</b> Metallwarenfabrik GmbH D-28340 Leichter, Germany Phone: +49(0)82177294 Fax: +49(0)8217728-1000 info@wanzl.de		max. 4x 1000kg 1000kg 1000kg 1000kg	max. 2x 0 kg 0 kg	STOP STOP
10-10m max. 10m	max. 1000kg 1000kg	max. 4x 1000kg 1000kg 1000kg 1000kg		

**SAFE HANDLING**  
 Clear information on load capacity and stackability shown directly on the attachment

**PA-X1/5  
 PALLET BOXES**  
 Closing grate on the long side can be folded back

# 03.15 Pallet Boxes

■ **For bulk items or heavy goods**, with pallet boxes on Euro pallets, your products are transported and presented safely and cleanly.

### Reliable fixture

**Four latching bars** on the narrow sides ensure the load is kept secure on the Euro pallet.



### Safe stacking

**Stacking corners** with large contact surfaces and high edges prevent the box from slipping.



### Divider (optional)

**Fits all models** with closed long sides. Dimensions 715 x 725 mm. Mesh size 73 x 70 mm.



### Intermediate grate (optional)

**Fits all models.** For variable attachment in 70 mm grid. High load capacity. Mesh size 25 x 125 mm.



**Design:** Sturdy pallet boxes in folding or closed design. Secure thanks to stacking corners with large support surface. 2 retaining bars on each of the narrow sides. Also available in non-stacking version.  
**Finish:** High-gloss, galvanised, chrome-plated.

### Basket attachment

**Fits stackable models** with two closed narrow sides. With scannable price rail.



Pallet boxes				
Closing grates fold back	PA-X/S stackable		PA-X/N non-stackable	
	Long side PA-X1/S	Narrow side PA-X2/S	Long side PA-X1/N	Narrow side PA-X2/N
	<b>Order no.</b> 06.00 002.50	<b>Order no.</b> 06.00 008.50	<b>Order no.</b> 06.00 017.50	<b>Order no.</b> 06.00 025.50
Loading capacity (kg)	1000	1000	1000	1000
Max. stackability, empty	2	2	-	-
Max. stackability, loaded	4	4	-	-
Weight (kg)	29	29	29	29
<b>Accessories</b>				
Divider 715 x 725 mm	27.58 692.50	27.58 692.50	27.58 692.50	27.58 692.50
Intermediate grate 800 x 1200 mm	28.61 392.50	28.61 392.50	28.61 392.50	28.61 392.50
Attachment basket	07.41 810.50	-	-	-

Pallet boxes can be folded back on multiple sides, pallet edging version available on request.

## 03.16 KMF Stacking Baskets

*A variety of baskets of equal width can be stacked in staggered arrangements*

- > *Extremely resilient and stable*
- > *For clear product presentation*
- > *Fast and easy stacking*



**KMF STACKING BASKET**  
with wire stacking foot  
and accessories

### *Adjustable, easy separation*

**Dividers are easy to insert** and can be positioned variably.



**Equipment:** Solid wire construction with 8 mm thick edging wire. Each wire crossover is spot-welded. Upright flat plates on the basket floor, designed to take high stress.

**Finish:** High-gloss galvanised and chrome-plated. Coloured plastic powder-coated finish available on request.

### *Wire stacking foot*

**Extremely resilient foot construction** with high stability.





# 03.16 KMF Stacking Baskets

■ **Stacking basket series** with slanted basket profile and wire stacking feet. For attractively staggered stacking. Also carries the German “electroplating technology” seal, as all Wanzl stacking baskets do.

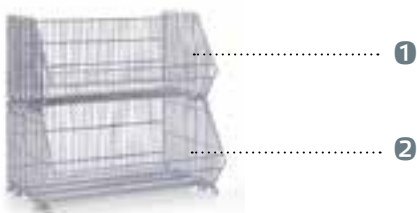

KMF – wire stacking feet



KMF – mobile chassis with dividers and price rails



KMF – mobile chassis with dividers

KMF stacking baskets (high-gloss galvanised and chrome-plated)		
<b>Shelf axis dimension 1000 mm</b>		
970 x 500 x 480 mm	Order no.	07.03 237.50
Weight / Loading capacity (kg)	10.4 / 60	<b>1</b>
<b>Accessories</b>		
Divider	27.03 241.50	
Attachment basket	07.00 339.50	
Diagonal grid*	28.20 240.50	
Scannable price rail	21.71 989.07	
970 x 595 x 480 mm	Order no.	07.03 236.50
Weight / Loading capacity (kg)	11.2 / 80	<b>2</b>
<b>Accessories</b>		
Divider	27.03 240.50	
Diagonal grid*	28.20 240.50	
Scannable price rail	21.71 989.07	
<b>Shelf axis dimension 1250 mm</b>		
1160 x 425 x 390 mm	Order no.	07.05 565.50
Weight / Loading capacity (kg)	9.6 / 60	<b>3</b>
<b>Accessories</b>		
Scannable price rail	21.71 993.07	
<b>Shelf axis dimension 1250 mm</b>		
1160 x 420 x 470 mm	Order no.	07.05 566.50
Weight / Loading capacity (kg)	11.5 / 60	<b>4</b>
<b>Accessories</b>		
Divider	27.03 287.50	
Scannable price rail	21.71 993.07	
1160 x 500 x 480 mm	Order no.	07.05 857.50
Weight / Loading capacity (kg)	12.0 / 60	<b>5</b>
<b>Accessories</b>		
Divider	27.03 241.50	
Mobile chassis	26.08 240.50	
Scannable price rail	21.71 993.07	
1160 x 595 x 480 mm	Order no.	07.08 022.50
Weight / Loading capacity (kg)	13.5 / 80	<b>6</b>
<b>Accessories</b>		
Divider	27.03 240.50	
Scannable price rail	21.71 993.07	
1160 x 670 x 480 mm	Order no.	07.08 021.50
Weight / Loading capacity (kg)	16.0 / 100	<b>7</b>
<b>Accessories</b>		
Divider	27.03 201.50	
Chassis, stationary	26.08 376.50	
Mobile chassis	26.08 246.50	
Scannable price rail	21.71 993.07	

\* Please order 2 inclined racks with each basket.

Stackable in staggered arrangements

## 03.17 KKF Stacking Baskets

*Identical baskets can always be stacked together*

- > *Extremely resilient and stable*
- > *For clear product presentation*
- > *Fast and easy stacking*



**KKF STACKING BASKET**  
with plastic stacking foot  
and accessories

### *Adjustable, easy separation*

**Dividers are easy to insert** and can be positioned variably.



**Equipment:** Solid wire construction with 8 mm thick edging wire. Each wire crossover is spot-welded. Upright flat plates on the basket floor, designed to take high stress.

**Finish:** High-gloss galvanised and chrome-plated. Coloured plastic powder-coated finish available on request.

### *Plastic stacking feet*

**Snap in** and prevent damage to sheet metal shelves.



# 03.17 KKF Stacking Baskets

■ **Stacking basket series** with slanted basket profile and plastic stacking feet that can be removed as needed. Carries the German “electroplating technology” seal, as all Wanzl stacking baskets do.



KKF – with dividers



KKF – plastic stacking feet



KKF – mobile chassis

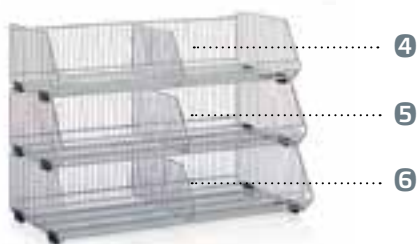

KKF – with dividers

KKF stacking baskets (high-gloss galvanised and chrome-plated)		
<b>Shelf axis dimension 1000 mm</b>		
955 x 400 x 350 mm	<b>Order no.</b>	07.18 516.50
Weight / Loading capacity (kg)	8.0 / 50	<b>1</b>
<b>Accessories</b>		
Divider	27.18 518.50	
Diagonal grid*	28.20 240.50	
Scannable price rail	21.71 988.07	
<b>Shelf axis dimension 960 mm</b>		
960 x 560 x 280 mm	<b>Order no.</b>	07.19 505.50
Weight / Loading capacity (kg)	9.0 / 75	<b>2</b>
<b>Accessories</b>		
Divider	27.19 538.50	
Diagonal grid*	28.20 240.50	
Scannable price rail	21.71 988.07	
<b>Shelf axis dimension 1200 mm</b>		
1200 x 640 x 465 mm	<b>Order no.</b>	07.10 936.50
Weight / Loading capacity (kg)	14.5 / 75	<b>3</b>
<b>Accessories</b>		
Divider	27.03 201.50	
Mobile chassis	26.10 969.50	
Scannable price rail	21.71 995.07	
<b>Shelf axis dimension 1200 mm</b>		
1200 x 490 x 280 mm	<b>Order no.</b>	07.27 082.50
Weight / Loading capacity (kg)	7.2 / 50	<b>4</b>
<b>Accessories</b>		
Divider	27.19 536.50	
Scannable price rail	21.71 995.07	
1200 x 540 x 280 mm	<b>Order no.</b>	
Weight / Loading capacity (kg)	9.5 / 50	<b>5</b>
<b>Accessories</b>		
Divider	27.19 537.50	
Scannable price rail	21.71 995.07	
1200 x 590 x 280 mm	<b>Order no.</b>	
Weight / Loading capacity (kg)	9.1 / 75	<b>6</b>
<b>Accessories</b>		
Divider	27.19 538.50	
Scannable price rail	21.71 995.07	

\* Please order 2 inclined racks with each basket.

Stackable in staggered arrangements

## 03.18 Shelf Baskets / Insert Baskets

For clear presentation of the product range

- > Staggered presentation of items with baskets of equal width
- > With nesting loops, up to 8 shelf insert baskets can be stacked on top of one another
- > Clean presentation of all kinds of items

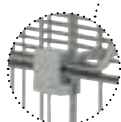

**SHELF INSERT BASKETS**  
stacked and adjacent,  
with scannable price rail

### PLASTIC NESTING LOOPS

- > With nesting loops, up to 8 shelf insert baskets can be stacked on top of one another and in offset position



**SHELF BASKET**  
model AK 15,  
with scannable price rail

### Shelf insert baskets

**Design:** Solid wire construction with 25 mm wire interval. Nesting loops made of unbreakable plastic.

**Finish:** High-gloss chrome-plated. High-gloss galvanised and chrome-plated or coloured plastic powder-coated finish available on request.

### Shelf baskets

**Design:** Baskets of robust steel wire. Mesh width at base 25 x 25 mm.







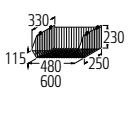
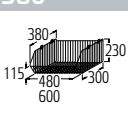
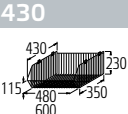
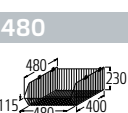
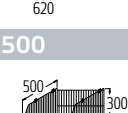
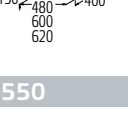
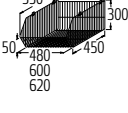
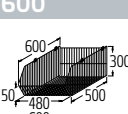

**Finish:** High-gloss chrome-plated. Coloured plastic powder-coated finish available on request.

# 03.18 Shelf Baskets / Insert Baskets

■ **Present cleanly, sell more** – both shelf insert baskets and shelf baskets bring more order to the store shelf.

Shelf insert baskets				
Basket width (mm)		480	600	620
Basket depth (mm)		Order no.	Order no.	Order no.
	330 with nesting loops	19.03 321.10	19.12 934.10	19.21 168.10
	without nesting loops	19.03 328.10	19.31 041.10	19.46 380.10
	Weight (kg)	1.8	2.0	2.2
	Divider	27.03 343.10	27.03 343.10	27.03 343.10
	Scannable price rail	21.71 976.07	21.71 982.07	21.71 984.07
	380 with nesting loops	19.03 322.10	19.31 039.10	19.23 841.10
	without nesting loops	19.03 329.10	19.31 042.10	19.46 381.10
	Weight (kg)	2.0	2.2	2.4
	Divider	27.03 344.10	27.03 344.10	27.03 344.10
	Scannable price rail	21.71 976.07	21.71 982.07	21.71 984.07
	430 with nesting loops	19.03 323.10	19.12 935.10	19.04 136.10
	without nesting loops	19.03 330.10	19.31 043.10	19.04 142.10
	Weight (kg)	2.2	2.5	2.6
	Divider	27.03 345.10	27.03 345.10	27.03 345.10
	Scannable price rail	21.71 976.07	21.71 982.07	21.71 984.07
	480 with nesting loops	19.03 324.10	19.31 040.10	19.03 335.10
	without nesting loops	19.03 331.10	19.31 044.10	19.03 339.10
	Weight (kg)	2.4	2.7	3.0
	Divider	27.03 346.10	27.03 346.10	27.03 346.10
	Scannable price rail	21.71 976.07	21.71 982.07	21.71 984.07
	500 with nesting loops	19.04 119.10	19.09 402.10	19.04 131.10
	without nesting loops	19.04 124.10	19.31 045.10	19.04 137.10
	Weight (kg)	2.8	3.3	3.4
	Divider	27.04 129.10	27.04 129.10	27.04 129.10
	Diagonal grid	28.20 240.10	-	-
	550 with nesting loops	19.04 120.10	19.12 864.10	19.04 132.10
	without nesting loops	19.04 125.10	19.31 046.10	19.04 138.10
	Weight (kg)	3.1	3.5	3.7
	Divider	27.04 130.10	27.04 130.10	27.04 130.10
	Diagonal grid	28.20 240.10	-	-
	600 with nesting loops	19.04 121.10	19.09 401.10	19.04 133.10
	without nesting loops	19.04 126.10	19.31 047.10	19.04 139.10
	Weight (kg)	3.4	3.8	3.9
	Divider	27.02 194.10	27.02 194.10	27.02 194.10
	Diagonal grid	28.20 240.07	-	-
	700 with nesting loops	19.02 192.10	19.09 499.10	19.04 134.10
	without nesting loops	19.02 193.10	19.31 048.10	19.04 140.10
	Weight (kg)	3.8	4.1	4.2
	Divider	27.02 195.10	27.02 195.10	27.02 195.10
	Diagonal grid	28.20 240.10	-	-
Scannable price rail		21.71 976.07	21.71 982.07	21.71 984.07
Loading capacity – all basket depths (kg)		40	50	50

### Stackable with:

-  Korbtiefe 330 mm
-  Korbtiefe 380 mm
-  Korbtiefe 430 mm
-  Korbtiefe 480 mm
-  Korbtiefe 500 mm
-  Korbtiefe 550 mm
-  Korbtiefe 600 mm
-  Korbtiefe 700 mm

Identical baskets with nesting loops can always be stacked. Baskets with nesting loops and of equal width can also be stacked in staggered arrangements.

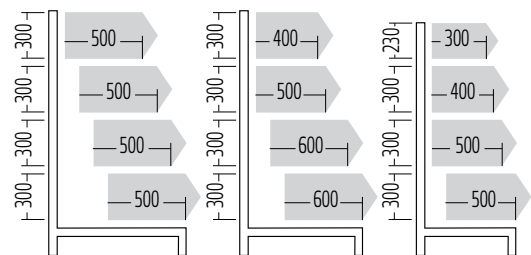

Wanzl's shelf insert baskets are individual components that can be put together to form a complete stacking system. There is a choice of baskets in three front widths and different heights and depths. Baskets of identical and different depths can be stacked offset.

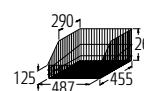
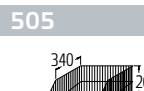
Shelf baskets		
Basket width (mm)		487
Basket depth (mm)		Order no.
	455	Model AK 15
	Weight (kg)	1.9
	Loading capacity (kg)	40
	505	Model AK 16
	Weight (kg)	2.1
	Loading capacity (kg)	40

## 03.19 Hang-In Basket Systems

*L series for normal loads, S series for heavy loads*

- > *System can be infinitely and variably combined*
- > *Complete freedom to arrange dividers – regardless of the shelf axis dimension*
- > *Optimal use of shelf space, no shelf surfaces required*



**HANG-IN BASKET L SERIES**  
for normal loads,  
shown with scannable price rails



**HANG-IN BASKET S SERIES**  
for heavy loads,  
shown with scannable price rails

### *Hang-in basket system, L series*

**Design:** Dimensionally stable baskets, reinforced on base with upright flat plates. Brackets with triple hooks make hooking in particularly easy, in horizontal position or inclined at 4.5° or 9°. L series with 25 mm wire interval for normal loads.

**Finish:** High-gloss galvanised and chrome-plated. Coloured plastic powder-coated finish available on request.

### *Hang-in basket system, S series*

**Design:** Dimensionally stable baskets, reinforced on base with upright flat plates. Brackets with triple hooks make hooking in particularly easy, in horizontal position or inclined at 4.5° or 9°. S series with 18 mm wire interval for heavy loads.

**Finish:** High-gloss galvanised and chrome-plated. Coloured plastic powder-coated finish available on request.

# 03.19 Hang-In Basket Systems

Hang-in basket system, L series			Hang-in basket system, S series		
Shelf axis dimension 665 mm		Order no.	Shelf axis dimension 665 mm		Order no.
	Shelf depth 370 mm	19.94 651.50		Shelf depth 370 mm	19.17 250.50
	Divider	27.94 667.50		Divider	27.16 439.50
	Weight (kg)	3.4		Weight (kg)	4.1
	Shelf depth 470 mm	19.94 652.50		Shelf depth 470 mm	19.17 251.50
	Divider	27.94 668.50		Divider	27.16 440.50
	Weight (kg)	4.1		Weight (kg)	4.8
	Shelf depth 570 mm	19.94 653.50		Shelf depth 570 mm	19.17 258.50
	Divider	27.94 669.50		Divider	27.16 441.50
	Weight (kg)	4.4		Weight (kg)	6.5
	Shelf depth 670 mm	19.94 654.50		Shelf depth 670 mm	19.70 616.50
	Divider	27.94 670.50		Divider	27.70 620.50
	Weight (kg)	5.2		Weight (kg)	7.2
Scannable price rail for shelf axis dimension 665 mm:		21.95 153.07	Scannable price rail for shelf axis dimension 665 mm:		21.71 918.07
Shelf axis dimension 1000 mm		Order no.	Shelf axis dimension 1000 mm		Order no.
	Shelf depth 370 mm	19.94 655.50		Shelf depth 370 mm	19.16 430.50
	Divider	27.94 667.50		Divider	27.16 439.50
	Weight (kg)	4.5		Weight (kg)	6.3
	Shelf depth 470 mm	19.94 656.50		Shelf depth 470 mm	19.16 431.50
	Divider	27.94 668.50		Divider	27.16 440.50
	Weight (kg)	4.8		Weight (kg)	7.2
	Shelf depth 570 mm*	19.94 657.50		Shelf depth 570 mm*	19.17 261.50
	Divider	27.94 669.50		Divider	27.16 441.50
	Weight (kg)	6.6		Weight (kg)	8.4
	Shelf depth 670 mm	19.94 658.50		Shelf depth 670 mm	19.70 617.50
	Divider	27.94 670.50		Divider	27.70 620.50
	Weight (kg)	7.0		Weight (kg)	9.0
Scannable price rail for shelf axis dimension 1000 mm:		21.95 154.07	Scannable price rail for shelf axis dimension 1000 mm:		21.71 920.07
Shelf axis dimension 1250 mm		Order no.	Shelf axis dimension 1250 mm		Order no.
	Shelf depth 370 mm	19.94 659.50		Shelf depth 370 mm	19.16 433.50
	Divider	27.94 667.50		Divider	27.16 439.50
	Weight (kg)	6.2		Weight (kg)	7.4
	Shelf depth 470 mm	19.94 660.50		Shelf depth 470 mm	19.16 434.50
	Divider	27.94 668.50		Divider	27.16 440.50
	Weight (kg)	6.8		Weight (kg)	8.5
	Shelf depth 570 mm*	19.94 661.50		Shelf depth 570 mm*	19.17 264.50
	Divider	27.94 669.50		Divider	27.16 441.50
	Weight (kg)	8.1		Weight (kg)	10.2
	Shelf depth 670 mm	19.94 662.50		Shelf depth 670 mm	19.70 618.50
	Divider	27.94 670.50		Divider	27.70 620.50
	Weight (kg)	8.4		Weight (kg)	12.4
Scannable price rail for shelf axis dimension 1250 mm:		21.95 155.07	Scannable price rail for shelf axis dimension 1250 mm:		21.71 922.07
Shelf axis dimension 1330 mm		Order no.	Shelf axis dimension 1330 mm		Order no.
	Shelf depth 370 mm	19.94 663.50		Shelf depth 370 mm	19.16 436.50
	Divider	27.94 667.50		Divider	27.16 439.50
	Weight (kg)	5.6		Weight (kg)	8.1
	Shelf depth 470 mm	19.94 664.50		Shelf depth 470 mm	19.16 437.50
	Divider	27.94 668.50		Divider	27.16 440.50
	Weight (kg)	7.4		Weight (kg)	9.7
	Shelf depth 570 mm*	19.94 665.50		Shelf depth 570 mm*	19.17 267.50
	Divider	27.94 669.50		Divider	27.16 441.50
	Weight (kg)	8.3		Weight (kg)	11.5
	Shelf depth 670 mm	19.94 666.50		Shelf depth 670 mm	19.70 619.50
	Divider	27.94 670.50		Divider	27.70 620.50
	Weight (kg)	8.8		Weight (kg)	13.2
Scannable price rail for shelf axis dimension 1330 mm:		21.95 156.07	Scannable price rail for shelf axis dimension 1330 mm:		21.71 924.07
Loading capacity – shelf axis dimensions (kg)		60	Loading capacity – shelf axis dimensions (kg)		90

### Triple hooks



For tailored product presentation

### 4 basket depths

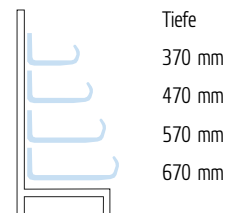

Enable staggered unloading

### Divider

Divider intervals governed by the wire interval of series:



L series, 25 mm



S series, 18 mm

\* Offset baskets for heavy-duty shelves with supports available on request.

# 04.01 Garden Centres

*Optimised solutions for garden centres, nurseries, etc.*

- > Shopping and transport trolleys specially designed for gardening products and plants
- > Intelligent entrance systems reduce inventory losses
- > Optimal and highly flexible product presentation systems



**GT 26 eco®**  
page 38



**PLANTER D + P** – with wire basket or plastic tray  
page 35



**GARDENER 100**  
page 34



**MUC® 300**  
Page 27



**SCANDY S**  
page 32



**GC 100-3**  
page 33



**eGate® DOUBLE SYSTEM**  
page 52



**BARGAIN TABLE P**  
page 70



**VARIO FLOWER DISPLAY**  
page 76



**MOBILO**  
page 77



# 04.01 Garden Centres



**KMF STACKING BASKETS**  
page 96



**KKF STACKING BASKETS**  
page 98

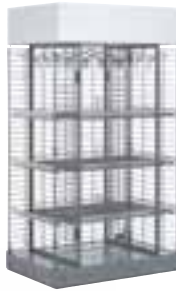

**POSSIBILITY**  
page 88



**PALETTI**  
page 90



**PALLET BOXES**  
page 94



**AD 100 JOY**  
page 86

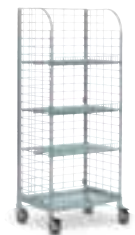

**AD 300**  
page 86



**CUBE®**  
page 80



120 litres    320 litres    180 litres

**BARGAIN BASKETS**  
Page 72



**GVK 1    GVK 2    GVK 3**

**GVK SALES BASKETS**  
Page 72



**ROLL DESK\***  
with steel plate cabinet,  
door locks with safety  
lock.

**\* MORE INFORMATION IS  
AVAILABLE THROUGH YOUR  
PARTNER FOR CONSULTATIONS**

# 04.02 Beverage Retailers

*Robust, durable and cost-effective: equipment for beverage retailers.*

- > Heavy loads are easily manoeuvred with Wanzl transporters and shopping trolleys
- > Optimised, versatile presentation of seasonal and promotional items
- > Customer guidance systems protect assets and guide customers reliably



**MUC® 950**  
page 27



**MUC® 300\***  
with child seat



**MUC® 200**  
page 27



**PICK-UP\***



**GT 26 eco®**  
page 38



**OV 17\***



**GC 100-3**  
page 33



**DRC SERIES**  
page 14



**KMF STACKING BASKETS**  
page 96



**KKF STACKING BASKETS**  
page 98



**SHELF INSERT BASKETS / SHELF BASKETS**  
page 100



**L+S SERIES HANG-IN BASKETS**  
page 102



# 04.02 Beverage Retailers



BUMPER BARS



NX STAINLESS STEEL GUIDE RAIL



TECHNOLINE GUIDE RAIL

BUMPER SYSTEMS  
page 64



PRO TEC 3° BUMPER SYSTEM



CORNER PROTECTORS \*  
floor- or wall-mounted



RAILIX PARTITION SYSTEM®  
page 62



POSTER DISPLAY \*



AD 100 JOY  
page 86



AD 300  
page 86

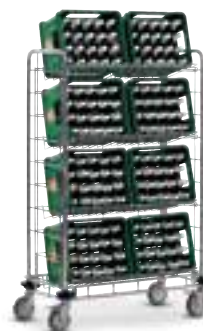

FW-8 BOTTLE TROLLEY\*

\* MORE INFORMATION IS  
AVAILABLE THROUGH YOUR  
PARTNER FOR CONSULTATIONS

# 04.03 Health Food Stores

*Representative, practical and effective: the Wanzl product range for the organic sector*

- > Shopping trolleys and baskets specially designed for small and medium-sized spaces
- > Using appealing natural materials for a true environmentally-conscious overall image
- > Simple, efficient separation of waste



**TANGO CITY**  
page 16



**TANGOLINO**  
page 20



**DR22**  
page 20



**GT 26 eco®**  
page 38



**EL 75**  
page 10



**EL 90**  
page 10



**CITY-SHOPPER 2**  
page 18



**PICK-UP**  
with wicker baskets  
page 40



**MOBILO**  
page 77



# 04.03 Health Food Stores



SERVICE CENTRE\*



SERVICE TOWER\*



SERVICE POINT\*



BASKET PRESENTATION STANDS  
page 74

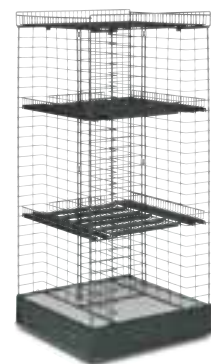

POSMODUL 7/7 (MODULE 2)  
Page 92



SWING SLOPING DISPLAY  
page 78



SWING DISPLAY STAND\*



AD 100 JOY  
page 86

\* MORE INFORMATION IS AVAILABLE THROUGH YOUR PARTNER FOR CONSULTATIONS

# 04.04 Furniture Centres

*Fun and design for the furniture centre: improve customer satisfaction with Wanzl*

- > Fun for children and parents with the Wanzl FunMobil line
- > Complete solutions for universal, appealing product presentation
- > Intelligent entrance systems reduce inventory losses



KIDDO\*



CITY-SHOPPER 2  
page 18



DRC SERIES  
page 14



SHOP & ROLL  
page 42



GT 26 eco®  
page 38



FUNMOBIL 80  
page 22



FUNMOBIL COMPACT 140  
page 22



FURNITURE TROLLEYS  
page 30



eGATE  
page 52



S CHECKOUT BARRIER,  
SELF-LOCKING  
page 58

# 04.04 Furniture Centres



**BASKET PRESENTATION STANDS**  
page 74

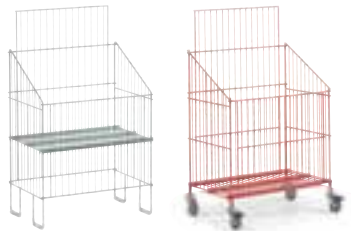

**JOKER DISPLAY**  
page 74



**GVK SALES BASKETS**  
page 72



**BARGAIN TABLES**  
page 72



**DESIGN 99**  
page 69



**CUBE®**  
page 80



**POSSIBILITY**  
page 88



**TWINN®**  
page 82



**ROLL DESK\***  
with steel plate cabinet,  
door locks with safety  
lock

**\* MORE INFORMATION IS  
AVAILABLE THROUGH YOUR  
PARTNER FOR CONSULTATIONS**

## GERMANY

Wanzl Metallwarenfabrik GmbH  
Bubesheimer Straße 4  
89340 Leipheim

Phone +49 (0) 8221 / 729-0  
Fax +49 (0) 8221 / 729-1000

info@wanzl.de  
www.wanzl.com

## GREAT BRITAIN

Wanzl Ltd.  
Europa House  
Heathcote Lane  
Warwick CV34 6SP

Phone +44 (0) 1926 / 45 1951  
Fax +44 (0) 1926 / 45 1952

enquiries@wanzl.co.uk  
www.wanzl.co.uk

## AUSTRALIA

Wanzl Australia Pty. Ltd.  
97 Highbury Road  
BURWOOD VIC 3125

Phone +61 (0) 3 / 98 08 22 99  
Fax +61 (0) 3 / 98 08 22 66

info@wanzl.com.au  
www.wanzl.com.au