

# CATÁLOGO DE PRECIOS

# 63

**PVP. Tarifa Venta al Público**  
Descuento según condiciones

**instal.**



**metal.**



**cotek.**

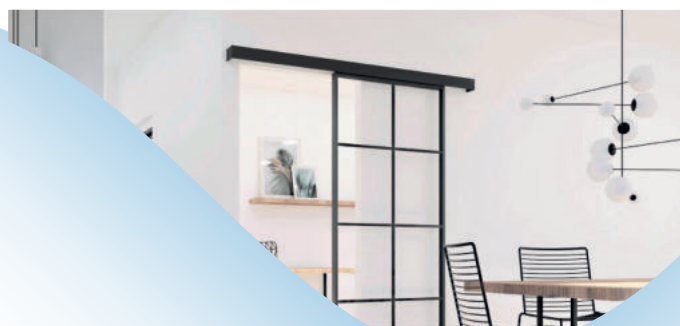

ED. 07/23

VIGOR:  
**01/07/2023**

**PEDIDOS / ATENCIÓN AL CLIENTE**

Teléfono +34 938 492 055 - Whatsapp +34 627 287 698  
e-mail: pedidos@alusystem.es - [www.alusystem.com](http://www.alusystem.com)

## ACABADOS

- 00 BRUTO
- 01 ALUMINIO ANODIZADO PLATA MATE
- 02 ALUMINIO ANODIZADO PLATA BRILLO
- 03 ALUMINIO ANODIZADO ORO MATE
- 06 ALUMINIO ANODIZADO TIPO TITANIO
- 09 PLÁSTICO
- 22 ACERO INOXIDABLE PULIDO BRILLO
- 28 ACERO INOXIDABLE SATINADO
- 31 CROMO MATE
- 32 CROMO BRILLO
- 33 CROMO ORO BRILLO
- 35 CROMO ORO MATE
- 34 CINCADO
- 38 CROMADO SATIN NIKEL
- 0N NEGRO
- 0B BLANCO
- 0P PINTADO NO METALIZADO Y 9006

OTROS COLORES: CONSULTAR

## FINITIONS

- 00 BRUT
- 01 ALUMINIUM ANODISÉ NATUREL MAT
- 02 ALUMINIUM ANODISÉ NATUREL BRILLANT
- 03 ALUMINIUM ANODISÉ DORÉ MAT
- 06 ALUMINIUM ANODISÉ TITANIUM
- 09 PLASTIQUE
- 22 INOX POLI
- 28 INOX SATINÉ
- 31 CHROMÉ MAT
- 32 CHROMÉ BRILLANT
- 33 CHROMÉ BRILLANT DORÉ
- 35 CHROMÉ MAT DORÉ
- 34 PLAQUÉ ZINC
- 38 SATIN NIKEL CHROMÉ
- 0N NOIR
- 0B BLANC
- 0P PEINTURE NON MÉTALLISÉE

AUTRES COULEURS: CONSULTER

## FINISHES

- 00 RAW FINISH
- 01 ALUMINIUM ANODIZED NATURAL MATT
- 02 ALUMINIUM ANODIZED NATURAL BRIGHT
- 03 ALUMINIUM ANODIZED GOLD MATT
- 06 ALUMINIUM ANODIZED TITANIUM
- 09 PLASTIC
- 22 POLISHED STAINLESS STEEL
- 28 SATIN STAINLESS STEEL
- 31 MATT CHROME
- 32 BRIGHT CHROME
- 33 BRIGHT CHROME GOLD
- 35 MATT CHROME GOLD
- 34 ZINC PLATED
- 38 SATIN NIKEL CHROME
- 0N BLACK
- 0B WHITE
- 0P PAINTED NO METALIZED AND 9006

OTHER COLORS: CONSULT

## FINITURE

- 00 GREZZO
- 01 ALLUMINIO ANODIZZATO NATURALE
- 02 ALLUMINIO ANODIZZATO NATURALE LUCIDO
- 03 ALLUMINIO ANODIZZATO DORATO
- 06 ALLUMINIO ANODIZZATO TITANIO
- 09 PLASTICA
- 22 INOX LUCIDO
- 28 INOX SATINATO
- 31 CROMO OPACO
- 32 CROMO LUCIDO
- 33 CROMATO DORATO LUCIDO
- 35 CROMATO DORATO OPACO
- 34 ZINCATO
- 38 CROMATO SATINATO NIKELATO
- 0N NERO
- 0B BIANCO
- 0P VERNICIE NO METALIZZATA

ALTRI COLORI: CONSULTEARE

## MEDIDAS

mesures - measures - misure



precio de 1 pieza  
Prix pour 1 pièce  
Price for 1 piece  
prezzo per 1 pezzo



precio de 1 metro de perfil  
prix d'un mètre de profil  
price of 1 meter profile  
prezzo di 1 metro di profilo

## REFERENCIAS

item codes - références - codici articoli

4040/102

ref. artículo / item code / référence / codice articolo  
barras / bars / barres / verghe  
acabado / finish / finitions / finitura

4041/032

ref. artículo / item code / référence / codice articolo  
pieza / piece / pièce / pezzo  
acabado / finish / finitions / finitura

1 = 1m facturación por metro lineal  
billing per linear meter  
facturation au mètre linéaire  
fatturazione per metro lineare



2 = 2m  
3 = 3m  
4 = 4m  
5 = 5m facturación por unidad  
billing per unit  
facturation par unité  
fatturazione per unità



## ABREVIATURAS

abréviations - abbreviations - abbreviazioni

20 kg/u peso max. rec.  
max. weight rec.  
poids max. rec.  
carico mass.o rac.

L 5 m longitud  
length  
longueur  
lunghezza

10-12 mm espesor  
thickness  
espesseur  
spessore

∅ 15 mm taladro - avellanado  
perforation - vis à tête fraisée  
drill - countersunk screw  
foratura - svasatura

∞ 2556 en unión con ...  
en union avec ...  
together with ...  
insieme a ...

66 m en rollos  
en rouleaux  
in coils  
in bobine

material / material / matériau / materiale  
Al aluminio - aluminium, alluminio  
inox / s.s. inox - stainless steel  
Cu latón - laiton, brass, ottone  
Zn zamak - zinc alloyed, zama  
Fe hierro - fer, iron, ferro  
plas plástico - plastique, platic, plastica

muesca / encoche / cut-out / tacca  
con - avec, with, con  
sin - sans, without, senza

max./min. ↔ 100/160 ancho - largeur, width, larghezza  
↓ 125/190 alto - hauteur, height, altezza

ángulo de apertura / angle d'ouverture / opening angle / angolo d'apertura  
0°-90°-180° punto de retención: en rojo  
point de rétention: en rouge  
retention point: in red  
punto di ritenzione: in rosso

## OBSERVACIONES

observations - remarks - osservazioni

REFERENCIAS CON ASTERISCO \*:

Prix en rouge et en italique \*:

references with asterisk \*:

codici con asterisco \*:

hasta agotar existencias - consultar nuestro almacén para confirmar disponibilidad

jusqu'à épuisement du stock - consultez notre maga sin pour confirmer la disponibilité

while stocks last - please consult our store to confirm availability

fino esaurimento stock - consultare il nostro magazzino per confermare la disponibilità

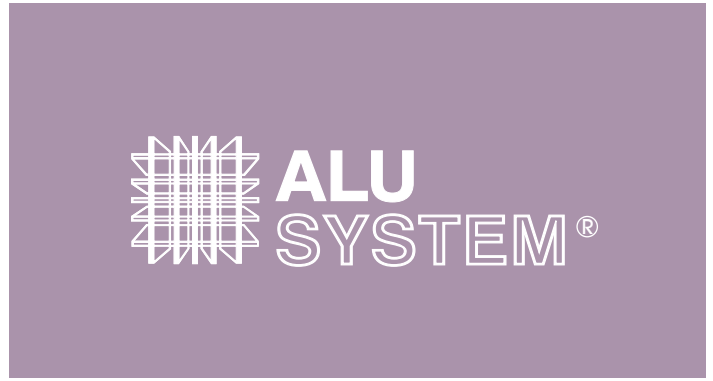

## CALIDAD QUALITÉ - QUALITY - QUALITÀ

Según los datos proporcionados por los proveedores Alu System afirma:  
Selon les données fournies par les fournisseurs Alu System stipule:  
According to data provided by suppliers Alu System states:  
Secondo i dati forniti dai fornitori Alu Sistema afferma:

### HERRAJES COTEK

ACCESSOIRES COTEK - COTEK FITTINGS - ACCESSORI COTEK

#### Ensayo en niebla salina: TEST APROBADO

latón y zamak : 240 h en solución al 5% NaCl  
aluminio 120 horas en solución al 5% NaCl  
acero inox: piezas en 304: en raros casos se han detectado pequeñas microincrustaciones superficiales (en ambiente extremadamente agresivos); pieza en 316: no se han detectado problemas

Test de brouillard salin: TEST APPROUVÉ

pièces en laiton et zamak: 240 h dans une solution de NaCl à 5%  
aluminium: 120 h dans une solution de NaCl à 5%  
Acier inoxydable: pièces en 304: dans de rares cas ont été détectés petite surface micro échelle (en environnement très agressif); pièces en 316: Aucun problème n'a été détecté

Salt spray test: APPROVED TEST

brass and zink alloyed items: 240 h in 5% NaCl solution  
aluminium: 120 h in 5% NaCl solution  
Stainless steel 304 pieces: in rare cases have been detected small micro-inlays surface (in very aggressive environment); Stainless steel 316: no problems detected

Test di nebbia salina: TEST APPROVATO

articoli in ottone e zamak: 240 h in soluzione al 5% NaCl  
aluminio: 120 h in soluzione al 5% NaCl  
Acciaio inossidabile: articoli in 304: raramente si sono riscontrate piccole microincrostazioni superficiali (in ambienti estremamente aggressivi); articoli in 316: non sono stati riscontrati problemi

### PERFILES DE ALUMINIO

PERFILES D'ALUMINIUM - ALUMINIUM PROFILES - PROFILI IN ALLUMINIO

Aleación de aluminio, alliage d'aluminium, aluminum alloy, lega di alluminio:  
6063-T5

Anodización, anodisation, anodizing, anodizzazione:

standard 6-8 mc.

Delphos: 15 mc.

### PINTURA

PEINTURE - PAINTING - VERNICIATURA

Los productos pintados en epoxi/poliéster tienen un espesor medio de 80-90 mc.

Produits peints epoxy/polyester ont une épaisseur moyenne de 80 à 90 mc.

Painted products epoxy/polyester have an average thickness of 80-90 mc.

Prodotti verniciati in epossidico/poliesteri hanno uno spessore medio di 80-90 mc.

## ¡¡¡IMPORTANTE! IMPORTANT! IMPORTANTE!

### MUESCAS, ENCOCHES, CUT-OUT, TACCHE

1. Herrajes que necesitan mecanización del cristal: se recomienda comprobar las medidas de los taladros y las muescas con los herrajes en la mano, antes de proceder a la mecanización.

Quincaillerie besoin mécanisation de verre: Il est recommandé de vérifier les dimensions des trous et encoches avec le matériel en main, avant la mécanisation.

Hardware needing mechanization of glass: It is recommended to check the dimensions of the holes and cut-out with the hardware in hand, before proceeding to mechanization.

Accessori che richiedono la meccanizzazione del vetro: Si consiglia di verificare le dimensioni dei fori e delle tacche con l'articolo in mano, prima della meccanizzazione.

2. Los dibujos son indicativos y no constituyen ninguna vinculación contractual.

Les dessins sont à titre indicatif et ne constituent pas une relation contractuelle.

The drawings are indicative and do not constitute any contractual relationship.

I disegni sono indicativi e non costituiscono alcun rapporto contrattuale.

3. Alu System se reserva el derecho de efectuar modificaciones sin previo aviso en las características de los productos presentados en el catálogo. Así mismo, Alu System no asume la responsabilidad de los cambios introducidos en los productos por el fabricante de los mismos.

Alu System se réserve le droit d'apporter des modifications sans préavis les caractéristiques des produits dans le catalogue. De même, Alu System assume aucune responsabilité pour des changements dans les produits par le constructeur.

Alu System reserves the right to make changes without notice in the characteristics of the products in the catalog. Likewise, Alu System assumes no responsibility for changes made in the products by the manufacturer.

Alu System si riserva il diritto di apportare modifiche senza preavviso alle caratteristiche dei prodotti in catalogo. Allo stesso modo, Alu System non si assume alcuna responsabilità per cambiamenti introdotti nei prodotti da parte dello stesso produttore.

### MANTENIMIENTO, MAINTENANCE, MAINTENANCE, MANUTENZIONE

4. Limpiar las piezas cromadas sólo con agua y con jabón neutro. Alu System no se responsabiliza de daños provocados por uso de productos de limpieza indebidos.

Nettoyez les pièces chromées uniquement avec de l'eau et du savon doux. Alu System ne est pas responsable des dommages causés par une mauvaise utilisation de produits de nettoyage.

Clean chrome parts only with water and mild soap. Alu System is not responsible for damage caused by improper use of cleaning products.

Pulire le parti cromate solo con acqua e sapone neutro. Alu System non è responsabile per i danni causati da un uso improprio dei prodotti per la pulizia.

### SUSTITUCIÓN, REPLACEMENT, SOSTITUZIONE

5. En caso de sustitución de productos, Alu System se hace cargo del material y del transporte pero no de la mano de obra de sustitución.

En cas de remplacement des produits, Alu System prend soin de matériaux et le transport, mais pas la substitution du travail

In case of replacement of products, Alu System takes care of materials and transport but not labor substitution

In caso di sostituzione di prodotti, Alu System si fa carico del materiale e del trasporto, però non de la mano d'opera della sostituzione.

### CATÁLOGO, CATALOGUE, CATÁLOGO

6. Alu System no se responsabiliza de posibles errores de tipografía o de imprenta.

Alu System ne est pas responsable des erreurs typographiques ou d'impression

Alu System isn't responsible for any errors in typography or printing.

Alu System non è responsabile per eventuali errori tipografici o di stampa.

7. Derechos reservados. No se autoriza ninguna reproducción total o parcial de la tarifa sin previa autorización por parte de Alu System.

Tous les droits sont réservés. Tout reproduction totale ou partielle est interdite sans autorisation préalable du Alu System

All rights reserved. Any full or partial reproduction is not permitted without prior authorization from Alu System













Tutti i diritti sono riservati. Qualsiasi riproduzione totale o parziale non è consentita senza previa autorizzazione di Alu System.

















# NUEVOS PRODUCTOS / T - 63



## COTEK DUCHAS







NEMO PLUS _____		C03
BISAGRA OPORTO _____		C03
MANILLA DOBLE DE ALUMINIO _____		C03
BISAGRA TEIDE - NUEVOS ACABADOS _____		C35
BISAGRA MALLORCA HIDRÁULICA _____		C35
BISAGRAS BISELADAS LUGO _____		C36
ACCESORIOS - ACABADO NEGRO MATE _____		C37
BARRAS DE REFUERZO TELESCÓPICAS Y NUEVOS ACABADOS _____		C42
CERRADURA PARA LAVABOS "PICO DE LORO" _____		C42
BARRA DE REFUERZO PERIMETRAL 19X19MM _____		C43
POMOS Y MANILLAS NUEVOS Y NUEVOS ACABADOS _____		C46
TAPAJUNTAS NEVAS _____		C47

## COTEK PUERTAS



PUERTA ELÉCTRICA AUTOMÁTICA PANAMÁ _____		C51
PUERTAS CORREDERAS Y TELESCÓPICAS CANTÓN MARCO _____		C73
FRENOS MIAMI Y BOSTON (FUERAS 5 Y 7 SUCESIVAMENTE) _____		C115
BISAGRA HIDRÁULICA PRAGA _____		C116
BISAGRA OPORTO _____		C116
BISAGRA HIDRÁULICA MALLORCA _____		C117
BISAGRAS BISELADAS LUGO _____		C118
TOPE DE SUELO _____		C120
PUERTA CANTÓN MARCO PIVOTANTE _____		C121
PERFILES PARA DIVISORIAS Y BASTIDOR DE PUERTAS _____		C125
BISAGRA LION - ACABADO NEGRO MATE _____		C125
BISAGRA GALICIA _____		C125
CERRADURAS Y CONTRACERRADURAS MONTSE _____		C127
CERRADURAS Y CONTRACERRADURAS MÓNICA - ACABADO NEGRO MATE _____		C128
MANILLA DOBLE DE ALUMINIO _____		C130

## COTEK ARQUITECTURA

SOPORTES SUELO BARANDILLA CON ILUMINACIÓN LED _____		C133
---	---	------

SOPORTES SUELO BARANDILLAS DUPLEX 2205		C138
SOPORTES SUELO BARANDILLAS INOX 316		C138
ÚTILES PARA EL MONTAJE DE BARANDILLAS DE VIDRIO AUTOPORTANTES		C138
PINZA PARA VIDRIOS 16-21MM		C139
LLAVE DE MONTAJE PARA REGULAR		C140
BOTONES Ø35MM REGULABLES		C140
SOPORTES PARA BARANDILLAS Y ESCALERAS DE VIDRIO		C140



## METAL

NUEVA VENTOSA CON BOMBA DE VACÍO		M03
COMPLEMENTO PARA MUEBLES SET DE IMÁN		M08
SMARTLOCKS PARA PUERTAS Y CAJONERAS		M12



## INSTAL KADÍ

CREMALLERA ELEKTRIFICADA FINAL 4874		i13
ENGANCHE PARA COLGAR PANELES - 10MM GROSOR		i13
CONECTOR PARA CARTELAS KADÍ ELEKTRIC		i14
DRIVER 100W Y MINICONECTOR 230V		i14
CARTELA ELECTRIFICADA PARA ESTANTE DE MADERA 4635 - 4636		i20
CREMALLERA PARA EMPOTRAR 4567		i24
CARTELAS PLANAS PARA TUBO 30X10		i29
CARTELAS PARA ESTANTES DE VIDRIO FINALES Y CENTRALES 5844 - 5845 - 5846 APTAS PARA TODO EL SISTEMA KADÍ		i30
CARTELA REFORZADA PARA BARRAS DE CUELGUE 5624 - 5625 - 5628 - 2929		i32-33
TIRANTES KADÍ PHARMA 4821		i51
NUDOS "BRIDAS", MONTAJE RÁPIDO Y FÁCIL KADÍ PRIMO PARA TUBO 25X25MM		i75

## INSTAL EASY

SISTEMA MAGNETIC LIGHT, CARRIL Y ACCESORIOS MAGNÉTICOS PARA LA ILUMINACIÓN DE ESTANTES Y VITRINAS		i89
SISTEMA EASY, DE ELECTRIFICACIÓN RÁPIDO Y ECONÓMICO		i91

## INSTAL OTROS

SOPORTE PARA ZAPATILLAS STAR 8		i129
STENDERS, SOPORTES CONFECCIÓN UNIVERSALES CON RUEDAS		i135



# COTEK

## HERRAJES Y COMPLEMENTOS METÁLICOS PARA EL VIDRIO

### HERRAJES PARA DUCHAS

**C-1**

PREMIUM / SELECCIÓN DE HERRAJE PARA DUCHA DE ALTA GAMA	C-3
NEMOPLUS LED / CORREDERAS PARA DUCHAS CON ILUMINACIÓN LED	C-3
OPORTO / BISAGRA HIDRÁULICA PARA DUCHAS	C-4
NEMO PLUS 40 KG / CORREDERA PARA DUCHA CON POSIBILIDAD DE ILUMINACIÓN LED - PARA VIDRIO 6/8 MM	C-05
NEMO 40 KG / CORREDERA PARA DUCHA PARA VIDRIO 6/8 MM	C-13
QUADRO 40 KG / CORREDERA PARA DUCHA CON SELF-CLOSING	C-17
OSLO 40 KG / PUERTA CORREDERA PARA DUCHA	C-23
TURÍN 40 KG / PUERTA CORREDERA PARA DUCHA	C-25
VERONA 40 KG / PUERTA CORREDERA PARA DUCHA CON RODAMIENTO INFERIOR	C-27
NICOLE 40 KG / PUERTA CORREDERA PARA DUCHA EN INOX 304	C-29
KOBE DUCHA 80 KG / PUERTA CORREDERA PARA DUCHA CON SELF-CLOSING	C-31
ROMA / PERFIL BISAGRA DE ALUMINIO PARA PLATO DE DUCHA Y BAÑERA VIDRIO 6 MM, 30 KG	C-33
TEIDE / BISAGRA PARA DUCHA CON RETENCIÓN - VIDRIO 6/8 MM, 15/18 KG/U - LATÓN, INOX Y ZAMAK	C-35
MALLORCA / BISAGRA PARA DUCHA CON RETENCIÓN - VIDRIO 8/10 MM, 22 KG/U - LATÓN, INOX Y ZAMAK	C-35
MALLORCA HÍDRAULICA / BISAGRA PARA DUCHA CON RETENCIÓN- INOX 304, VIDRIO 8/10 MM, 20KG	C-35
IBIZA / BISAGRA PARA DUCHA CON RETENCIÓN - INOX 316 VIDRIO 8/10 MM, 22 KG/U	C-36
LANZAROTE / BISAGRA PARA DUCHA CON RETENCIÓN - INOX DUPLEX VIDRIO 8/10 MM, 22 KG/U	C-36
LUGO / BISAGRA PARA DUCHA CON EJE REGULABLE Y RETENCIÓN - VIDRIO 8/10 MM, 22 KG/U, LATÓN	C-36
MALLORCA PLUS / BISAGRA PARA DUCHA CON TAPAS Y RETENCIÓN - VIDRIO 8/10 MM, 22 KG/U, LATÓN MACIZO	C-37
MALLORCA Regulable / BISAGRA PARA DUCHA CON EJE REGULABLE Y CON RETENCIÓN - VIDRIO 8/10 MM, 22 KG/U, LATÓN	C-37
MENORCA / BISAGRA PARA DUCHA CON EJE REGULABLE Y RETENCIÓN - VIDRIO 8/10, MM 22 KG, LATÓN MACIZO	C-37
GAMA NEGRO / SELECCIÓN DE HERRAJES EN NEGRO MATE	C-37
NIZA PLUS / BISAGRA BASCULANTE CON RETENCIÓN - VIDRIO 8/10 MM 22 KG, LATÓN MACIZO	C-40
NIZA / BISAGRA BASCULANTE CON EJE DE ALTA RESISTENCIA Y RETENCIÓN - VIDRIO 8/10 MM 22 KG, LATÓN MACIZO	C-40
LISBOA / BISAGRA PARA DUCHA SIN RETENCIÓN INOX 304 APTA PARA PUERTAS PLEGABLES, VIDRIO 6/8 MM, 20 KG/U, INOX 304	C-40
VENECIA / BISAGRA PARA DUCHA SIN RETENCIÓN - VIDRIO 6/8 MM, 20 KG/U, LATÓN	C-40
MONACO / BISAGRA PARA DUCHA SIN RETENCIÓN - VIDRIO 6/8 MM, 20 KG/U, LATÓN	C-40
MORSETOS/ HERRAJES FIJOS	C-41
PERFILES LATERALES PARA FIJOS	C-41
BARRAS DE REFUERZO	C-42
CERRADURA LAVABO	C-42
REFUERZO PERIMETRAL TUBO CUADRADO / 19X19 MM	C-43
REFUERZO PERIMETRAL TUBO REDONDO / Ø19 MM	C-44
REFUERZO PERIMETRAL TUBO / 30X10 MM	C-45
POMO, TIRADORES Y UÑEROS PARA DUCHA	C-46
TAPAJUNTAS	C-47

### HERRAJES PUERTAS - CORREDERAS

**C-49**

CORREDERAS PREMIUM / SELECCIÓN DE HERRAJE DE ALTA GAMA	C-51
PANAMÁ 80KG / PUERTA CORREDERA CON MOTOR DE ELECTROIMÁNES - VIDRIO 8/10MM	C-51
PLEGABLES CENTRAL 80 KG / PUERTAS PLEGABLES DE ACORDEÓN CON GUÍA CENTRAL	C-55
PLEGABLE DESPLAZADA 80 KG / PUERTAS PLEGABLES DE ACORDEÓN CON GUÍA DESPLAZADA	C-57
KOBE 80KG / PUERTA CORREDERA DE CUELQUE PARA VIDRIO DE 8/10 MM Y SELF-CLOSING	C-59
KYOTO 120KG / PUERTA CORREDERA DE CUELQUE PARA VIDRIO DE 10/12 MM Y SELF-CLOSING	C-61
CANTON 80 KG / PUERTA CORREDERA PARA VIDRIO 8/10 MM CON O SIN SELF-CLOSING	C-63
CANTON MARCO 80 KG / PUERTA CORREDERA ENMARCADA CON PERFIL DE ALUMINIO PARA VIDRIO 8 MM Y SELF-CLOSING	C-65
CANTON MARCO INVISIBLE / PUERTA CORREDERA ENMARCADA CON GUÍA OCULTA	C-73
CANTON MARCO TELEX 80 KG / PUERTAS CORREDERAS TELESCÓPICAS SINCRONIZADAS CON 2 O 3 HOJAS ENMARCADAS CON	
PERFIL DE ALUMINIO PARA VIDRIO 8 MM Y SELF-CLOSING	C-75
SERENA 80KG / PUERTAS CORREDERAS PARA VIDRIO DE 8/12 MM	C-87

SYNCR0 80KG / PUERTAS CORREDERAS SINCRONIZADAS	C-89
TELEX 80 KG / PUERTAS CORREDERAS TELESCÓPICAS SINCRONIZADAS DE 2 O 3 PUERTAS PARA VIDRIO DE 8/12 MM	C-91
TOKYO 90 KG / PUERTA CORREDERA DE GUELGUE 90 KG - SELF-CLOSING	C-95
SHANGHAI 60KG / PUERTA CORREDERA DE CUELGUE PARA VIDRIO DE 8-10 MM Y SELF-CLOSING	C-96
PLATEK 100KG / PUERTA CORREDERA INOX 304 - VIDRIO 10/12 MM	C-97
PISA 100KG / PUERTA CORREDERA PARA VIDRIO 8/10 MM CON SELF-CLOSING	C-99
MONZA 100KG / PUERTA CORREDERA PARA VIDRIO DE 8/10 MM CON SELF-CLOSING Y POSIBILIDAD DE EMPOTRAR EN EL TECHO	C-103
RIMINI 80 KG / PUERTAS CORREDERAS CON GUÍA INVISIBLE - VIDRIO 8-10 MM	C-109
VIGO 80 KG / PUERTA CORREDERAS DE ALUMINIO PARA VIDRIO 8-10 MM	C-112

## HERRAJES PUERTAS - BATIENTES DE PASO C-114

BISAGRAS HYDRAULICAS PREMIUM / SELECCIÓN DE HERRAJE DE ALTA GAMA	C-115
AMSTERDAM / FRENO PIVOTANTE SIN EMPOTRAR INOX 304 100KG - VIDRIO 8-12 MM	C-115
MIAMI / FRENO PIVOTANTE SIN EMPOTRAR INOX 316 150KG - VIDRIO 8-12 MM	C-115
BOSTON / FRENO PIVOTANTE SIN EMPOTRAR FORZA 7 PARAT PUERTAS EXTERIORES INOX 316 100KG VIDRIO 8-12 MM	C-116
PRAGA / BISAGRA HIDRÁULICA A PARED CON RETENCIÓN - INOX 304, VIDRIO 8-10 MM 30 KG/U	C-116
OPORTO / BISAGRA HIDRÁULICA A PARED CON RETENCIÓN - ALUMINIO, VIDRIO 8-10 MM 20/30 KG/U	C-116
RIO / BISAGRA HIDRÁULICA PARED CON RETENCIÓN - VIDRIO 8/12 MM, 25 KG/U, INOX 304	C-117
MALLORCA HÍDRAULICA / BISAGRA PARA DUCHA CON RETENCIÓN- INOX 304, VIDRIO 8/10 MM, 20KG	C-117
LONDRES / FRENO PIVOTANTE SIN EMPOTRAR INOX 304 - VIDRIO 8-12 MM, 100 KG,	C-117
ZURICH / BISAGRA AUTOMÁTICA CON RETENCIÓN - VIDRIO 8/12 MM, 25 KG/U, ZAMAK	C-118
SUIZA / BISAGRA AUTOMÁTICA CON RETENCIÓN - VIDRIO 8/12 MM, 25 KG/U, LATÓN	C-118
LUGO / BISAGRA PARA DUCHA CON EJE REGULABLE Y RETENCIÓN - VIDRIO 8/10 MM, 22 KG/U, LATÓN	C-118
MENORCA / BISAGRA PARA DUCHA CON EJE REGULABLE Y RETENCIÓN - VIDRIO 8/10 MM, 22 KG/U, LATÓN	C-118
FRENOS / CIERRAPUERTA PARA EMPOTRAR 120/135 KG	C-119
PLINTO / VIDRIO 10/15 MM, 100KG	C-119
MALAGA / VIDRIO 10 MM, 70 KG	C-120
MARINA / VIDRIO 10/12 MM, 60 KG - BISAGRAS PIVOTANTES PARA PUERTAS EN INOX 304	C-120
TOPES PUERTAS	C-120
CANTON MARCO PIVOTANTE / PUERTA PIVOTANTE ENMARCADA CON PERFIL DE ALUMINIO PARA VIDRIO 8 MM, 80 KG	C-121
PERFIL PERIMETRAL MAMPARAS DIVISORIAS / PARA VIDRIO DE 10/12 MM	C-125
PERFIL BASTIMENTO PUERTAS / EN ALUMINIO	C-125
LYON / BISAGRA SIN RETENCIÓN PARA PUERTA BATIENTE - VIDRIO 8/10 MM, 25 KG/U	C-125
VIENA / BISAGRA SIN RETENCIÓN PARA PUERTA BATIENTE - VIDRIO 8/10 MM, 25 KG/U	C-125
GALICIA / BISAGRA SIN RETENCIÓN PARA PUERTA BATIENTE - VIDRIO 8/10 MM, 25 KG/U	C-125
BONN / BISAGRA SIN RETENCIÓN PARA PUERTA BATIENTE CON FIJACIÓN FRONTAL - VIDRIO 8/10 MM, 30 KG/U	C-125
HERRAJES FIJOS	C-126
CERRADURAS PARA PUERTAS / SIN TACAS	C-127
CERRADURAS CORREDERAS	C-127
CERRADURA PUERTA BATIENTE "MONTSE"	C-127
CERRADURAS PUERTAS "MONICA"	C-128
CERRADURAS PUERTAS "SONIA"	C-128
CERRADURA "MARTA"	C-128
TIRADORES Y MANILLAS	C-129
POMOS Y UÑERO	C-130

## HERRAJES PARA ARQUITECTURA C-132

BARANDILLAS Y MARQUESINAS	C-133
BARANDILLAS PREMIUM / SELECCIÓN DE HERRAJE DE ALTA GAMA	C-133
SOPORTE SUELO CON ILUMINACIÓN SIN TALDROS / SOPORTES CON SISTEMA DE REGULACIÓN PATENTADO Y SISTEMA DE ILUMINACIÓN LED INTEGRADO EN LA BASE - VIDRIO 12-17,5 MM, INOX DUPLEX 2205	C-134
BOTON AUSTRAL / SOPORTES PARED CON SISTEMA DE REGULACIÓN PATENTADO - VIDRIO 10-22 MM, INOX DUPLEX 2205	C-135
SOPORTES SUELO REGULABLES SIN TALDROS / SOPORTES CON SISTEMA DE REGULACIÓN PATENTADO - VIDRIO 12-17,5 MM, INOX DUPLEX 2205	C-136
SOPORTES SUELO SIN TALADROS / AMPLIA GAMA EN INOX DUPLEX 2205 E INOX 316 - VIDRIO 10-22 MM	C-137
REFUERZO BARANDILLAS / VIDRIO 10-22 MM, INOX DUPLEX 2205	C-138
PINZAS / AMPLIA GAMA DE PINZAS EN INOX DUPLEX E INOX 316 - VIDRIO DE 6 A 22 MM	C-139
BOTONES / SOPORTES PARED CON SISTEMA DE REGULACIÓN - VIDRIO 10-22 MM, INOX DUPLEX 2205, INOX 316 E 304	C-140
PASAMANOS / TUBO Ø42 MM Y ACCESORIOS PARA PASAMANO - VIDRIO 12-22 MM, INOX 316L Y INOX DUPLEX	C-141
MARQUESINAS / HERRAJES PARA MARQUESINAS - VIDRIO 12-16 MM, INOX 304	C-142



# METAL

## COMPLEMENTOS PARA VIDRIO Y MADERAS

### COMPLEMENTOS CORTE DEL VIDRIO

### C-1

VENTOSAS / *MANIPUACIÓN VIDRIO Y MADERA*

M-3

PEQUEÑA HERRAMIENTA PARA EL CORTE DEL VIDRIO

M-4

KARR1 / *VIDRIO 5/6 MM*

M-5

KARR3 / *VIDRIO HASTA 10 MM*

M-6

CORREDERA PLÁSTICO

M-7

ANGULOS Y US

M-7

CERRADURAS PARA VITRINAS

M-7

BISAGRAS PARA MUEBLES-VITRINAS

M-8

PORTAESTANTES

M-9

UNIÓN ESTANTERÍA VIDRIO

M-9

PASAMONEDAS

M-9

GUÍAS Y CARTELAS

M-10

DISPLAY, MARCOS PARA RÓTULOS

M-11

COMPLEMENTOS ESPEJOS Y PATAS PARA MESAS DE VIDRIO

M-11

BISAGRAS HYDRÁULICAS PARA PUERTAS DE MADERA

M-12

SMARTLOCKS PARA PUERTAS Y CAJONES

M-12

FACILPLUS / *FRENTE DE ARMARIOS PARA MADERA*

M-13

ARPLUS / *FRENTE DE ARMARIOS PARA MADERA Y VIDRIO*

M-13

PUERTAS CORREDERAS DE PASO CANTÓN MADERA

M-15

PUERTAS CORREDERAS DE PASO LIMA MADERA

M-17

PUERTAS CORREDERAS DE PASO MATEK MADERA

M-18

CLICK / *SISTEMAS DE PERFILERÍA DE ALUMINIO PARA MOSTRADORES Y VITRINAS*

M-19



# INSTAL

## SISTEMAS MODULARES PARA MOBILIARIO COMERCIAL

### SISTEMA KADÍ

SISTEMA DE ORGANIZACIÓN VERTICAL DE ESTANTERIAS BASADO EN CREMALLERAS CON EL MISMO PASO Y ACCESORIOS COMUNES

**KADÍ ELEKTRIC** / GUÍA-CREMALLERES ELECTRIFICADAS CON SISTEMA DE ILUMINACIÓN INTEGRADO A LOS ESTANTES

**CREMALLERAS** / GUÍA-CREMALLERES Y ACCESORIOS PARA ESTANTES

**COLUMNAS** / PERFILES PARA ESTANTERIAS SIN PANELADO

**PHARMA ELEKTRIC** / SISTEMA AUTOPORTANTE PARA PANELAR CON SISTEMA DE ILUMINACIÓN INTEGRADO A LOS MONTANTES Y A LOS ESTANTES

**PHARMA DUO** / SISTEMA AUTOPORTANTE Y ACCESORIOS PARA ESTANTES PARA PANELAR

**SEPARADORES Y PORTAPRECIOS**

**PRIMO ELEKTRIC** / SISTEMA AUTOPORTANTE CON SISTEMA DE ILUMINACIÓN INTEGRADO A LOS MONTANTES Y A LOS ESTANTES - TUBO 25X25 MM

**PRIMO** / SISTEMA AUTOPORTANTE Y ACCESORIOS PARA ESTANTES - TUBO 25X25 MM

I-2

I-3

I-21

I-37

I-39

I-57

I-64

I-65

I-81

### EASY LIGHT

SISTEMAS DE ILUMINACIÓN DE MUEBLES

**MAGNETIC LIGHT** / CARRIL ELECTRIFICADO CON LAMPARAS LED IMANTADOS

**EASY** / SISTEMA UNIVERSAL DE CARRILES ELECTRIFICADOS Y CONECTORES PARA ELECTRIFICAR CUALQUIER MUEBLE

**VARIO** / SISTEMA DE ILUMINACIÓN EMPOTRADO PARA MUEBLES

I-88

I-89

I-91

I-93

### LAMAS

SISTEMA DE ORGANIZACIÓN HORIZONTAL DE ESTANTERIAS BASADO, CON PERFILES HORIZONTALES Y ACCESORIOS COMUNES

**PERFILES Y ACCESORIOS OCULTOS**

**LAMAS "DM"**

**LAMAS "ALUMINIO"**

**ACCESORIOS PARA LAMAS**

**384 PARALELO** / RANURA PARA ACCESORIOS 5/8 MM

**OPTI 3** / RANURA PARA ACCESORIOS 3 MM

I-96

I-97

I-103

I-104

I-105

I-107

I-109

### MULTILAMA-VERTICAL

**PERFIL MULTILAMA** / PERFIL MULTILAMA PASO 12,5 MM Y ACCESORIOS

**VERTICAL** / SISTEMA TUBULAR CON ACCESORIOS COMUNES CON MULTILAMA

I-112

I-113

I-117

### OTROS SISTEMAS Y COMPLEMENTOS

**STAR 25** / CASQUILLOS CON ACCESORIOS Ø25 MM

**STAR 8** / CASQUILLOS CON ACCESORIOS Ø8MM

**CABLE DECO** / ACCESORIOS DESLIZANTES CON CABLE 1,5 MM - PARA ESTANTERÍAS DE VIDRIO/MADERA

**ÓPTICA** / EXPOSITORES CON O SIN SISTEMA DE SEGURIDAD ANTIROBO

**JS-25** / SISTEMA DE NUDOS PARA TUBO Ø25 MM

**STANDER** / SOPORTES DE CONFECCIÓN MOBILES

I-126

I-127

I-129

I-130

I-131

I-133

I-135

# OUTLET

OUTLET INSTAL

IO-1

OUTLET METAL

MO-1

OUTLET COTEK

CO-1

# cotek.

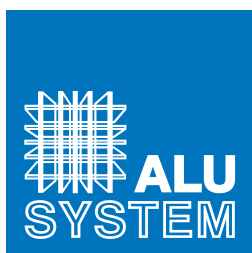

Herrajes  
para duchas

Herrajes  
para puertas de paso

Herrajes  
para arquitectura

**TARIFA 63**

01/07/2023

## COTEK - ÍNDEX

### HERRAJES PARA DUCHAS

#### 1- PREMIUM

03

A. NEMO PLUS Mampara con iluminación LED integrada  
opcional

B. OPORTO Bisagra hidráulica a pared con retención  
aluminio, vidrio 8-10 mm 25 kg/u

#### 2- CORREDERAS

05

#### 3- BISAGRAS

35

#### 4- HERRAJES FIJOS

41

#### 5- BARRAS

42

#### 6- POMOS

46

#### 7- JUNTAS

47

## ■ SERIE PREMIUM

# NEMO PLUS CON ILUMINACIÓN LED

Mampara con iluminación LED integrada opcional

- al** Aluminio
-  40 kg/puerta
-  6-8 mm
- 
-  Ancho máximo 100 cm
- ON  32 

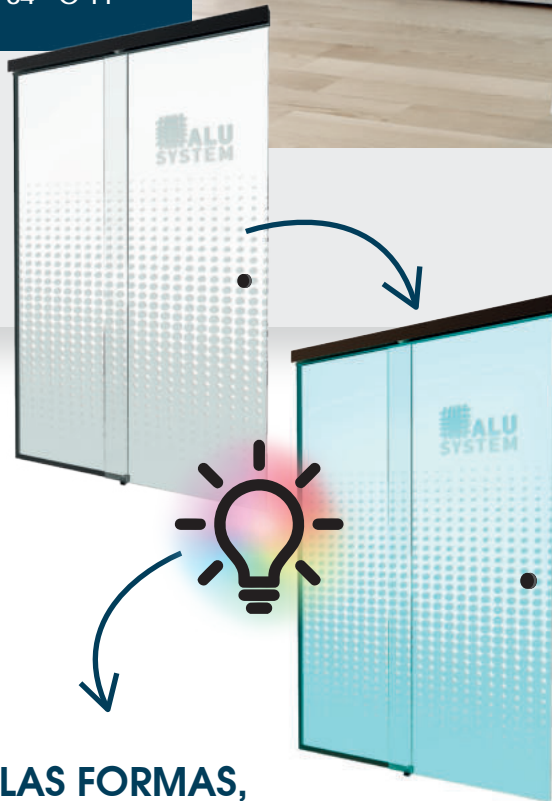

## MÁS INFORMACIÓN

páginas  
C 04 - C 11

**LAS FORMAS,  
BORDES Y DIBUJOS  
SE ILUMINAN  
CON EL LED**

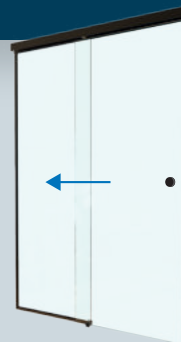
**NEMO PLUS  
180°****NEMO PLUS  
90°**✓ FÁCIL  
MONTAJE✓ VIDRIO FIJO  
SIN MUESCA✓ LED  
IP54✓ CARRIL  
SIN MECANIZACIÓN

Serie PREMIUM

**SERIE PREMIUM**

**BISAGRA OPORTO**

Bisagra hidráulica a pared con retención

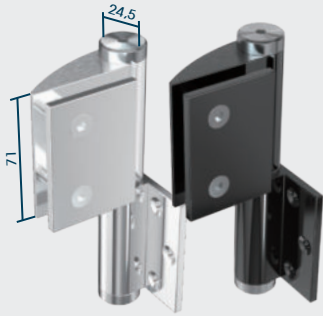

Bisagra hidráulica PARED - VIDRIO

- Penture haute
- Top pivoting hinge
- Cerniera superiore pivotante

€/u  
Derecha **1487/DON**  
Izquierda **1487/ZON**

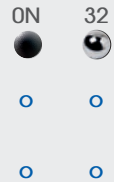

- al** Aluminio
- 25 kg/u
- más de 200.000 ciclos
- 8-10 mm

€/u  
Derecha **1488/DON**  
Izquierda **1488/ZON**

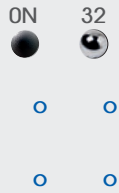

Bisagra hidráulica VIDRIO - VIDRIO

- Charnière hydraulique
- Hydraulic hinge
- Cerniera idraulica

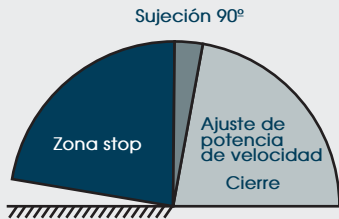
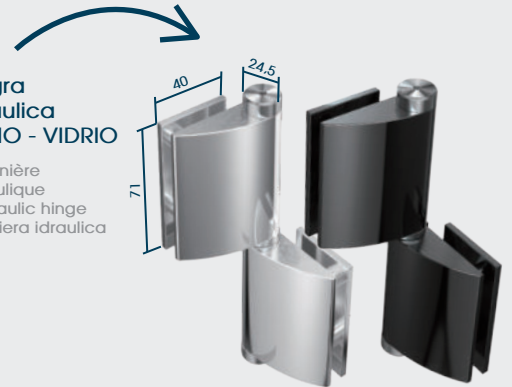

**DIRECCIÓN DE APERTURA**

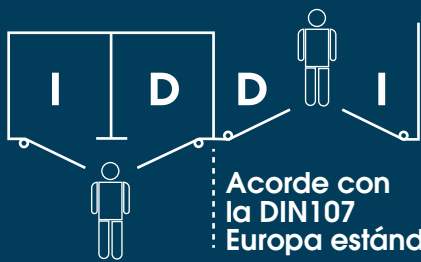

**FORMA DE AJUSTE**

Valor de velocidad y potencia en el lado de la bisagra



En el sentido de las agujas del reloj, el valor hace que la puerta se cierre más lentamente, en el sentido contrario a las agujas del reloj, hace que la puerta sea más rápida



En el sentido de las agujas del reloj, el valor hace que aumente la potencia de cierre, en el sentido contrario a las agujas del reloj, hace que la potencia de cierre se aligere

**1488/DON**

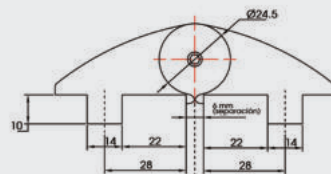

**1487/DON**

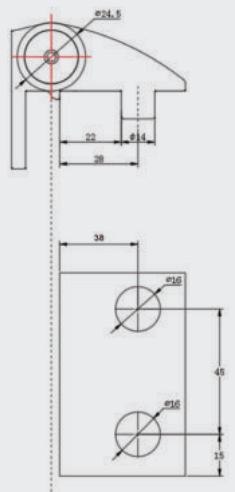
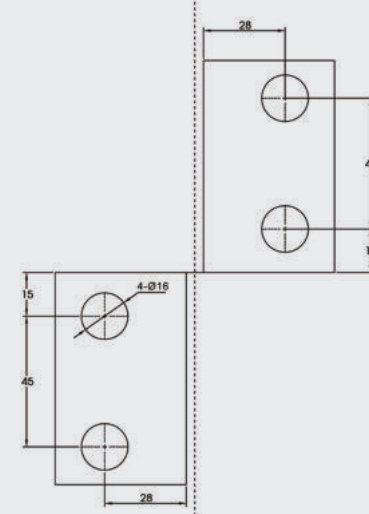

**Serie PREMIUM**

**COTEK - NEMO PLUS**

## POSIBLES APLICACIONES

**MAMPARA CON  
ILUMINACIÓN LED****NUEVO****LAS FORMAS  
BORDES Y DIBUJOS  
SE ILUMINAN  
CON EL LED**

- LOGOTIPOS
- DEGRADADOS
- DIBUJOS
- SANEFAS

Con técnicas como el ácido o el chorreado de arena, este sistema consigue resaltar creando una diferenciación que potencia la imagen de marca, creando patrones reconocibles, creando impacto en la experiencia de usuario y una ilusión visual que crea una ambientación ideal para momentos relajantes.

**¿QUÉ APORTA?****MÁS SENCILLEZ  
EN EL MONTAJE**

- ✓ VIDRIO FIJO  
**SIN MUESCA**
- ✓ CARRIL  
**SIN MECANIZACIÓN**
- ✓ **FÁCIL**  
MONTAJE

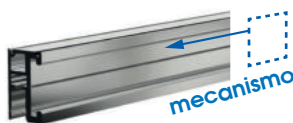
**SIN TAPA****CON TAPA**

- Carril sin ningún tipo de mecanizado.
- Se puede combinar con el perfil 4039, dejando los mecanismos ocultos para un acabado premium.



- Posibilidad de colocar vidrio laminado en el fijo, ya que no necesita ser mecanizado.

## COTEK - NEMO PLUS



### CREA AMBIENTACIONES CON LUZ BLANCA O DE COLORES



LEDs con control remoto, con rueda de colores, con posibilidad de crear diferentes bucles de color, colores fijos personalizados y variación de potencia de luz.

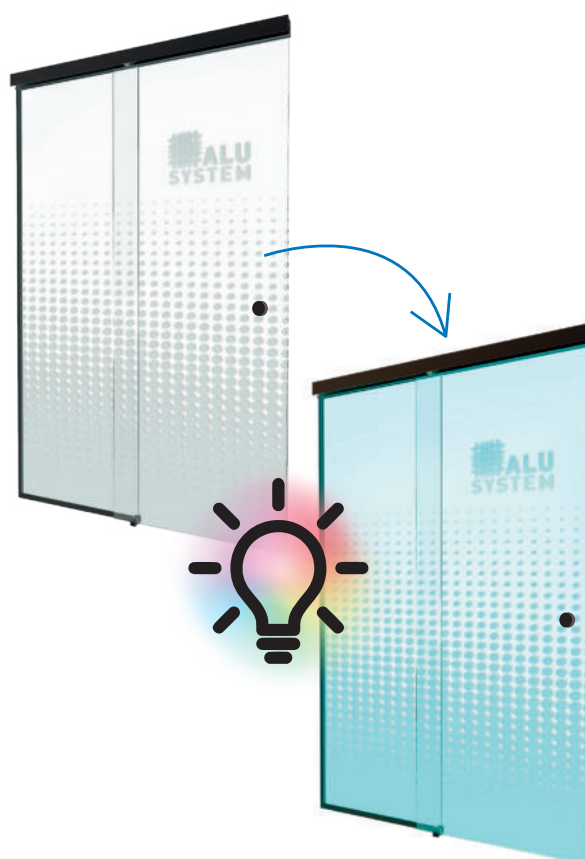

# COTEK - NEMO PLUS

## POSIBLES APLICACIONES

PUERTA MÓVIL  
VIDRIO FIJO

### NEMO PLUS 180°

1 PUERTA FIJA +  
1 PUERTA  
CORREDERA  
180°

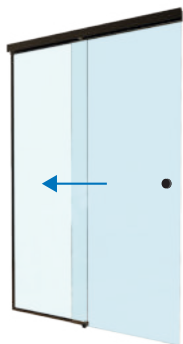

- D Apertura Derecha
- I Apertura Izquierda

**! NUEVO**

### NEMO PLUS 90°

1 PUERTA FIJA +  
1 PUERTA CORREDERA 180°  
+ 1 FIJO A 90°

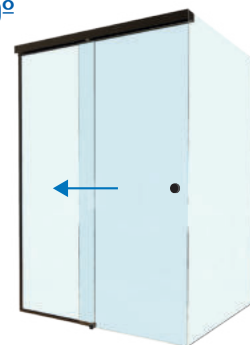
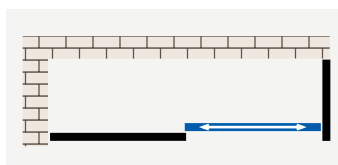

- D Apertura Derecha
- I Apertura Izquierda

**! NUEVO**

## DATOS GENERALES

### ACABADOS



#### VIDRIO

Puerta de vidrio /  
Carriles en aluminio  
plata y negro.

Vidrio de 6-8 mm

\* Para otros acabados,  
consultar pedido mínimo  
y plazo de entrega.

### PESO

PESO PUERTAS  
180° / 90° + FIJO



40 Kg/puerta  
peso max.

### CARACTERÍSTICAS



#### ILUMINACIÓN LED:

- PARA CREAR AMBIENTES,  
PROMOVER IMÁGEN DE MARCA Y  
PATRONES RECONOCIBLES, IMPACTO  
VISUAL O CREAR ESTÉTICAS  
ESPECIALES PARA UNIFICAR Y  
ARMONIZAR ESPACIOS.



TIPO DE LED: IP 54

### SOLAPE DE PUERTA Y FIJO

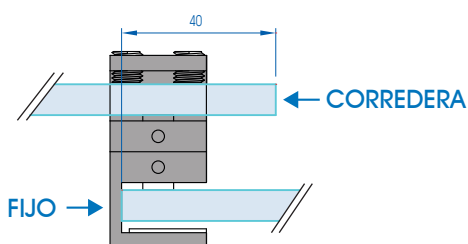

### MUESCA VIDRIO

- Muesca de la  
puerta para  
cojinetes 4041

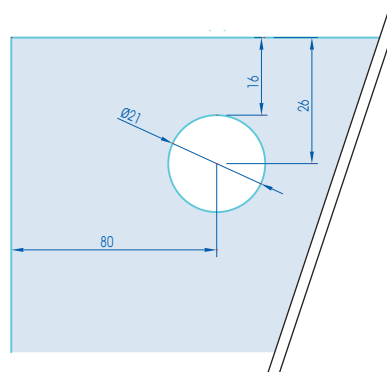



# COTEK - NEMO PLUS

## INSTALACIÓN

### CARRIL CON MECANISMO OCULTO

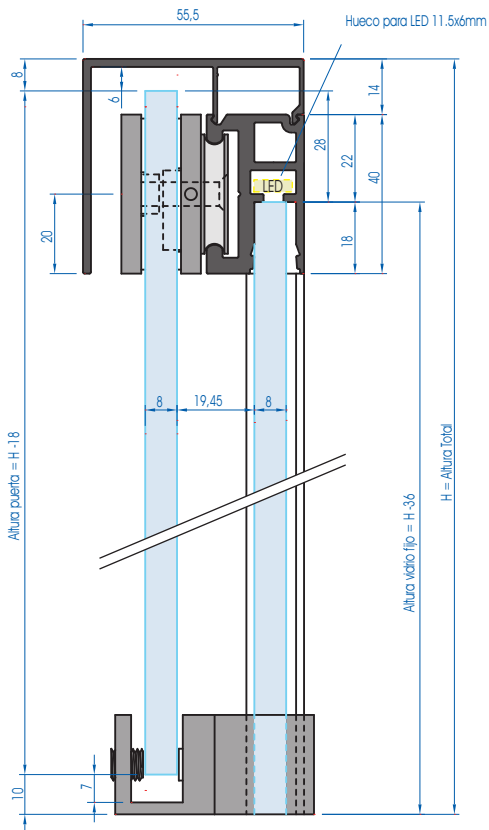

### CARRIL CON MECANISMO VISTO

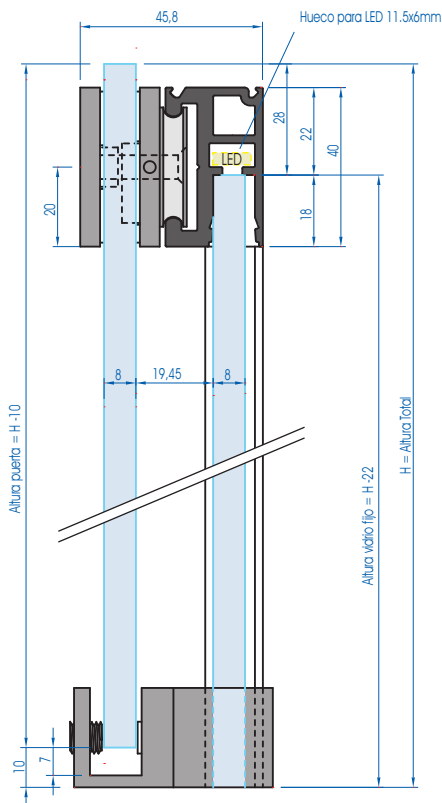

- Iluminación opcional en el vidrio fijo

Altura máxima a la que se puede subir el vidrio para regular la puerta = (±) 6mm

- Vidrios (puerta corredera y puerta fija)
- Piezas aluminio
- LED
- Latón

### PERFIL "U" EN EL LATERAL Y ABAJO

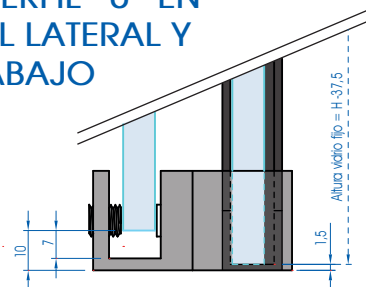

### PERFIL "U" EN EL LATERAL Y ABAJO

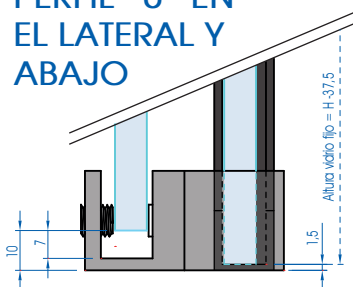

MUESCA VIDRIO TAPA LATERAL (NEMO PLUS 90°)

### CON TAPA

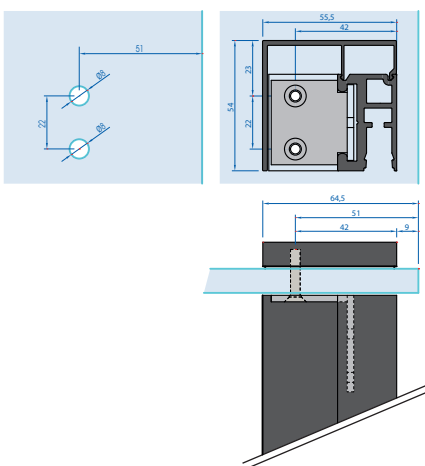

### SIN TAPA

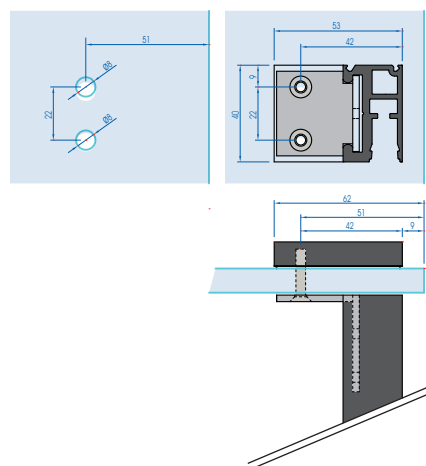



# COTEK - NEMO PLUS

## PIEZAS COMUNES



**CARRIL COULISSE HAUTE**  
UPPER TRACK  
GUIDA SUPERIORE  
4038/2..  
4038/3..

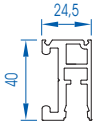

**TAPA COUVERCLE**  
RAIL COVER  
COPERCHIO  
4039/2..  
4039/3..

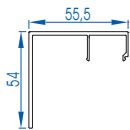

**COJINETE CHARLOT**  
ROLLER  
CUSCINETTO  
4041/0..



**ANCLAJE CARRIL - PARED**  
FIXATION MUR-COULISSE  
CONNEXION WALL-TRACK  
CONNESSIONE PARETTE-GUIDA  
4043/0..



**GUÍA SUELO**  
GUIDAGE AU SOL  
FLOOR GUIDE  
GUIDA A PAVIMENTO  
4046/0..



**STOP INTERIOR CARRIL**  
STOP CHARLOT  
STOP ROLLER  
STOP CUSCINETTO  
4044/0..

OPBRILLO CHR.POLI BR.CH-R OR.LUC	PLBR ALLBR ALLBR ALLLUC	NEGRO NOIR BLACK NERO
32	02	0N

Al	2m/3m	8-10	€/u
----	-------	------	-----

Al	2m/3m	€/u
----	-------	-----

Cu	Ø40 mm	6-8	€/u
	Ø15 mm		

Cu	€/u
----	-----

Cu	6-10	€/u
----	------	-----

Cu	€/u
----	-----

PLÁSTICO  
PLASTIQUE  
PLASTIC  
PLASTICA

09

# COTEK - NEMO PLUS



**"U" DE FIJACIÓN**  
FIXATION EN "U"  
"U" FIXING  
FISSAGGIO A "U"  
1659/10N 15x15x15 mm  $\varnothing$  10 mm max. 5m  
1657/10N 12x12x12 mm  $\varnothing$  8 mm max. 6m



4375/122 15x15x15 mm  $\varnothing$  12 mm max.  
4376/122 15x12x15 mm  $\varnothing$  8 mm max.  
4377/122 25x15x25 mm  $\varnothing$  12 mm max.



**PERFIL LATERAL ESTAQUEIDAD**  
PROFIL LATÉRAL D'ÉTANCHÉITÉ  
SEALING SIDE PROFILE  
PROFILO LATERALE DI TENUTA  
1851/109



**DIFUSOR PLÁSTICO MATE**  
DIFFUSEUR EN PLASTIQUE MAT  
MATT PLASTIC DIFUSOR  
DIFUSORE PLASTICO OPACO  
4896/209

Resistente al agua y a prueba de polvo.



**Módulo LED 10 cm IP 54**  
Resistente al agua y a prueba de polvo.

\* Posibilidad de LED COLOR RGB sobre pedido

**LED LUZ BLANCA 4000K, 24V, 14,2W/1M**  
LUMIÈRE BLANCHE LED  
LED WHITE LIGHT  
LUCE LED BIANCA  
4007/159



**TRANSFORMADOR 24V, 36W**  
TRANSFORMATEUR  
TRANSFORMER  
TRASFORMATORE  
4008/009

**IP 67**  
Resistente al agua y a prueba de polvo.



**PERFIL CUÑA PARA VIDRIO FIJO 8MM**  
PROFIL DE COIN POUR VERRE FIXE 8MM  
WEDGE PROFILE FOR FIXED GLASS 8MM  
PROFILO A CUNEO PER VETRO FISSO 8MM  
1844/109



**KIT TAPAS ILUMINACIÓN**  
KIT DE COUVERTURE D'ÉCLAIRAGE  
LIGHTING COVER KIT  
KIT COPERTURA ILLUMINAZIONE  
84038/009

INOX.BR INOX.POLI P.S.S INOX.LUC	NEGRO NOIR BLACK NERO	PLÁSTICO PLASTIQUE PLASTIC PLASTICA
22	0N	09

Al	5m	€/m
----	----	-----

lx	3m	€/u
----	----	-----

Pvc	2,2m	8mm	€/m
-----	------	-----	-----

Pla	2m	€/u
-----	----	-----

Pla	1,5m	€/u
-----	------	-----

Pla	€/u
-----	-----

Pvc	1m	8	€/m
-----	----	---	-----

Pla	€/u
-----	-----

# COTEK - NEMO PLUS

## PIEZAS PARA 90°

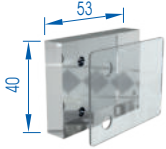

**CONEXIÓN 90° CARRIL - VIDRIO FIJO PARA NEMO PLUS 90° SIN TAPA (4039)**  
 FIXATION VERRE-COULISSE (SANS 4039)  
 CONNEXION GLASS-TRACK (WITHOUT 4039)  
 CONNESSIONE VETRO-GUIDA (SENZA 4039)  
**4030/O..**

Cu	8-10	Ø8mm	€/u
----	------	------	-----

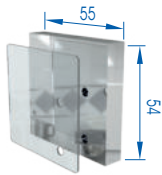

**CONEXIÓN 90° CARRIL - VIDRIO FIJO PARA NEMO PLUS 90° CON TAPA (4039) DERECHA**  
 FIXATION VERRE-COULISSE (AVEC 4039) DROITE  
 CONNEXION GLASS-TRACK (WITH 4039) RIGHT  
 CONNESSIONE VETRO-GUIDA (CON 4039) DESTRA  
**4031/D..**

Cu	8-10	Ø8mm	€/u
----	------	------	-----

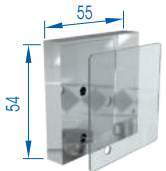

**CONEXIÓN 90° CARRIL - VIDRIO FIJO PARA NEMO PLUS 90° CON TAPA (4039) IZQUIERDA**  
 FIXATION VERRE-COULISSE (AVEC 4039) GAUCHE  
 CONNEXION GLASS-TRACK (WITH 4039) LEFT  
 CONNESSIONE VETRO-GUIDA (CON 4039) SINISTRA  
**4031/Z..**

Cu	8-10	Ø8mm	€/u
----	------	------	-----

## PIEZAS PARA 180° Y 90°

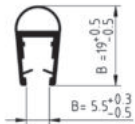

**PERFIL ESTANQUEIDAD PUERTA**  
 PROFILÉ D'ÉTANCHÉITÉ DE PORTE  
 DOOR SEALING PROFILE  
 PROFILO DI TENUTA DELLA PORTA  
**1830/109**

Pvc	2,2m	6-8	€/m
		PLÁSTICO	
		PLASTIQUE	
		PLASTIC	
		PLASTICA	
		<b>09</b>	

# COTEK - NEMO PLUS

## OTROS ACCESORIOS COMUNES

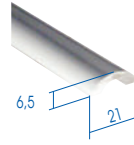

**PERFIL BURLETE DE ALUMINIO**  
 PROFILE LEVRE-UP  
 LIP-UP PROFILE  
 PROFILO VERTIACQUE  
**1831/2..**

Al	21x6,5mm	€/u
	2m	



**HERRAJE FIJO 90° PARED-VIDRIO**  
 FIXATION MUR-VERRE 90°  
 BRACKET WALL-GLASS 90°  
 MORSETTO PARETE-VERRO 90°  
**4108/Z..**

Zn	8-12	€/u
	Ø16mm	



**MORSETO VIDRIO-PARED**  
 FIXATION VERRE-MUR  
 BRACKET GLASS-WALL  
 MORSETTO VETRO-PATRETE  
**4105/032**

Cu	8-12	€/u
	Ø16mm	



**POMO**  
 POIGNÉE  
 KNOB  
 POMO  
**4047/0..**

Cu	Ø40 mm	6-10	€/u
	Ø10 mm		



**MANILLA DOBLE**  
 POIGNÉE DOUBLE  
 DOUBLE DOOR PULL  
 MANIGLIA DOPPIA  
**4139/Z..**

Zn	226x34mm	6-10	€/u
	Ø6mm (x2)		
	CC=191mm		

## MANILLA ALUMINIO



**MANILLA DOBLE**  
 POIGNÉE DOUBLE  
 DOUBLE DOOR PULL  
 MANIGLIA DOPPIA  
**4129/A32**  
**4129/A0Nnegro**

Al	6-10 mm	259x13	€/u
	2 x Ø 8 mm	CC=220 mm	





## COTEK - NEMO PLUS

CRIBILLO CH-ROU BR-CHR CR-LUC	NEGRO NOR BLACK NERO
32	ON

### KIT 180° DER/IZQ. CON TAPA (4039)

#### COMPONENTES

##### KIT BASE - 4033/B..

- 1u. 4038 2 M
- 1u. 4039 2 M
- 2u. 4041
- 2u. 4043
- 2u. 4044
- 1u. 4046
- 1u. 4047
- 1u. 1851/109 2,2 M (8mm)

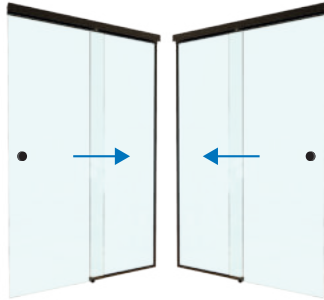

##### KIT + U - 4033/U..

- Kit base + :
- 1u. 4376 o 1657 3 M
  - 1u. 1830/109 2,2 M (6-8mm)



NO INCLUIDO:  
1831 - 4896 - LED

4033/B..	<input type="radio"/>	<input type="radio"/>
4033/U..	<input type="radio"/>	<input type="radio"/>

## COTEK - NEMO PLUS

CRIBILLO CH-ROU BR-CHR CR-LUC	NEGRO NOR BLACK NERO
32	ON

### KIT 90° DERECHA CON TAPA (4039)

#### COMPONENTES

##### KIT BASE - 4034/B..

- 1u. 4038 2 M
- 1u. 4039 2 M
- 2u. 4041
- 2u. 4043
- 1u. 4031/D
- 2u. 4044
- 1u. 4046
- 1u. 4047
- 1u. 1851/109 2,2 M (8mm)

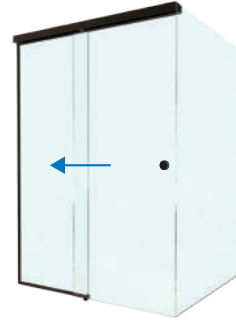

##### KIT + U - 4034/U..

- Kit base + :
- 1u. 4376 o 1657 6 M
  - 1u. 1830/109 2,2 M (6-8mm)

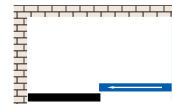

NO INCLUIDO:  
1831 - 4896 - LED

4034/B..	<input type="radio"/>	<input type="radio"/>
4034/U..	<input type="radio"/>	<input type="radio"/>

## KIT 180° DER/IZQ. SIN TAPA

#### COMPONENTES

##### KIT BASE - 4037/B..

- 1u. 4038 2 M
- 2u. 4041
- 2u. 4043
- 2u. 4044
- 1u. 4046
- 1u. 4047
- 1u. 1851/109 2,2 M (8mm)

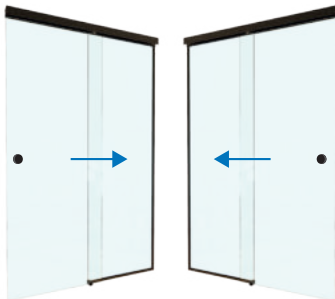

##### KIT + U - 4037/U..

- Kit base + :
- 1u. 4376 o 1657 3 M
  - 1u. 1830/109 2,2 M (6-8mm)



NO INCLUIDO:  
1831 - 4896 - LED

4037/B..	<input type="radio"/>	<input type="radio"/>
4037/U..	<input type="radio"/>	<input type="radio"/>

## KIT 90° DER/IZQ. SIN TAPA

#### COMPONENTES

##### KIT BASE - 4036/B..

- 1u. 4038 2 M
- 2u. 4041
- 2u. 4043
- 1u. 4030
- 2u. 4044
- 1u. 4046
- 1u. 4047
- 1u. 1851/109 2,2 M (8mm)

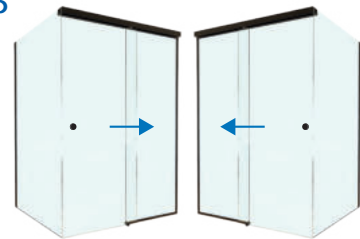

##### KIT + U - 4036/U..

- Kit base + :
- 1u. 4376 o 1657 6 M
  - 1u. 1830/109 2,2 M (6-8mm)

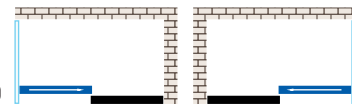

NO INCLUIDO:  
1831 - 4896 - LED

4036/B..	<input type="radio"/>	<input type="radio"/>
4036/U..	<input type="radio"/>	<input type="radio"/>

## COTEK - NEMO PLUS

ORBRILLO  
CHRPOU  
BRCHR  
ORLUC  
32  
NEGRO  
NOIR  
BLACK  
NERO  
ON

### KIT 90° IZQUIERDA CON TAPA (4039)

#### COMPONENTES

##### KIT BASE - 4035/B..

- 1u. 4038 2 M
- 1u. 4039 2 M
- 2u. 4041
- 2u. 4043
- 1u. 4031/Z
- 2u. 4044
- 1u. 4046
- 1u. 4047
- 1u. 1851/109 2,2 M (8mm)



##### KIT + U - 4035/U..

- Kit base + :
- 1u. 4376 o 1657 6 M
- 1u. 1830/109 2,2 M (6-8mm)

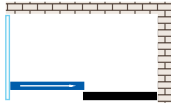

**NO INCLUIDO:**  
1831 - 4896 - LED

4035/B..	○	○
4035/U..	○	○

### KIT 90° CON 2 VIDRIOS FIJOS

#### COMPONENTES

##### CON TAPA (4039):

- KIT 4034/B32
- + 1u. 4031/D o Z

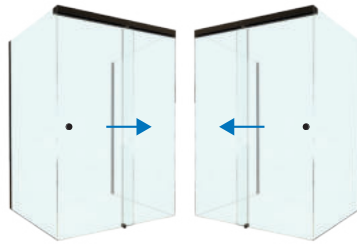

##### SIN TAPA:

- KIT 4036/B32
- + 1u. 4030

**NO INCLUIDO:**  
1831 - 4896 - LED



# COTEK - NEMO

CORREDERA PARA DUCHAS - COULISSANTS DOUCHE  
SCHOWER SLIDING DOOR - SCORREVOLI PER DOCCIA

## NEMO

- peso max: 40 kg/puerta (180° y 90°+fijo)
- peso max: 20 kg/puerta (2 puertas 90°)
- vidrio: 6-8 mm

- poids max: 40 kg/porte (180° et 90°+fixe)
- poids max: 20 kg/port (2 portes 90°)
- verre: 6-8 mm

- max weight: 40 kg/door (180° and 90°+fixed)
- max weight: 20 kg/door (2 doors 90°)
- glass: 6-8 mm

- peso max: 40 kg/porta (180° e 90°+fissjo)
- peso max: 20 kg/porta (2 porte 90°)
- vetro: 6-8 mm

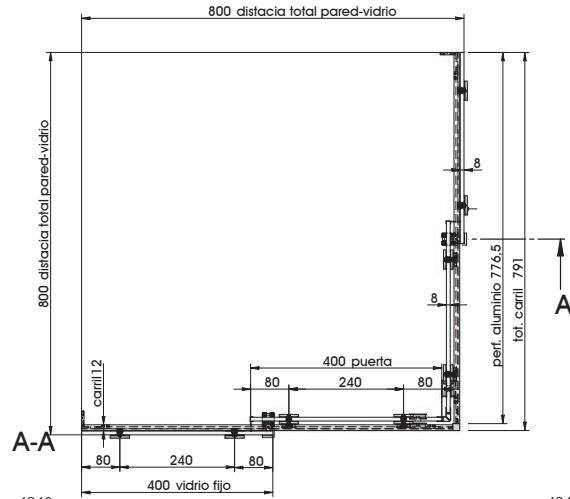
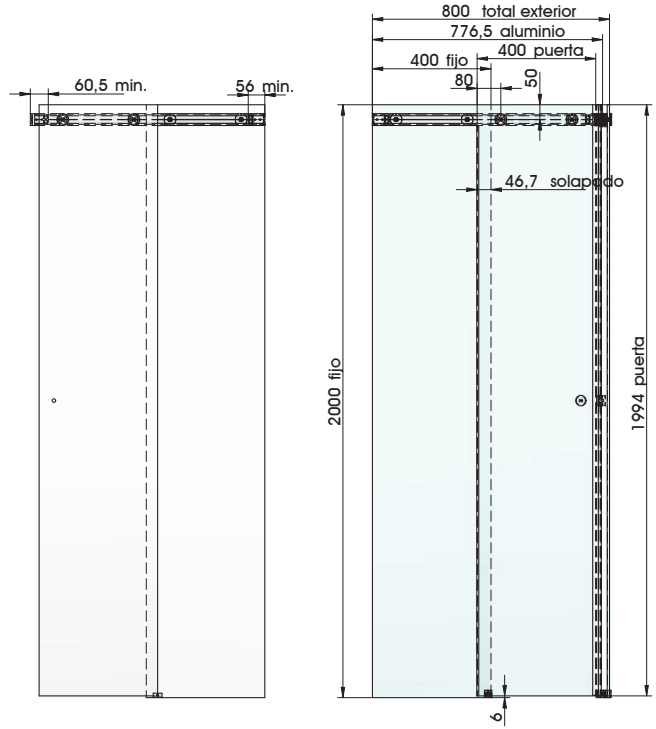

medida alto puerta = medida vidrio fijo - 6 mm  
medida vidrio fijo

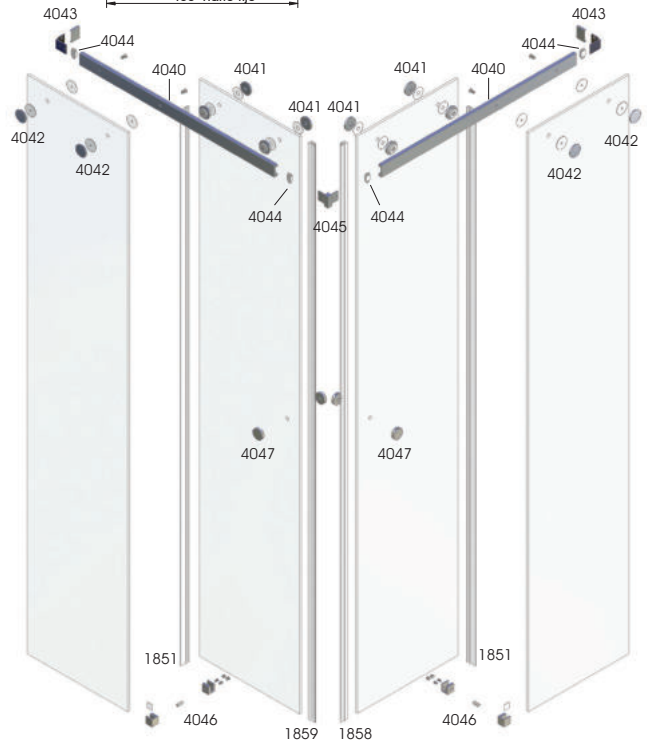
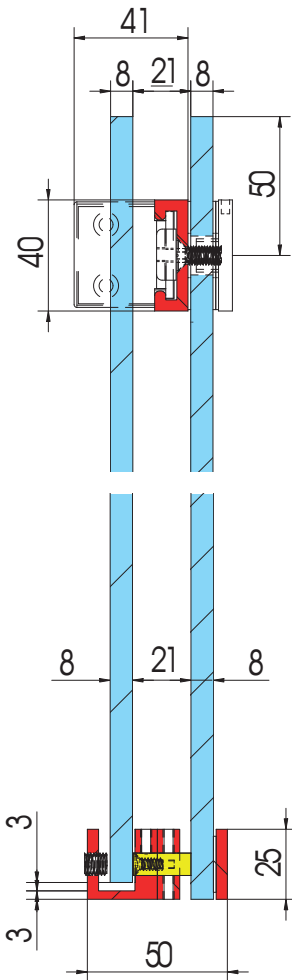

# COTEK - NEMO

CORREDERA PARA DUCHAS - COULISSANTS DOUCHE  
SCHOWER SLIDING DOOR - SCORREVOLI PER DOCCIA

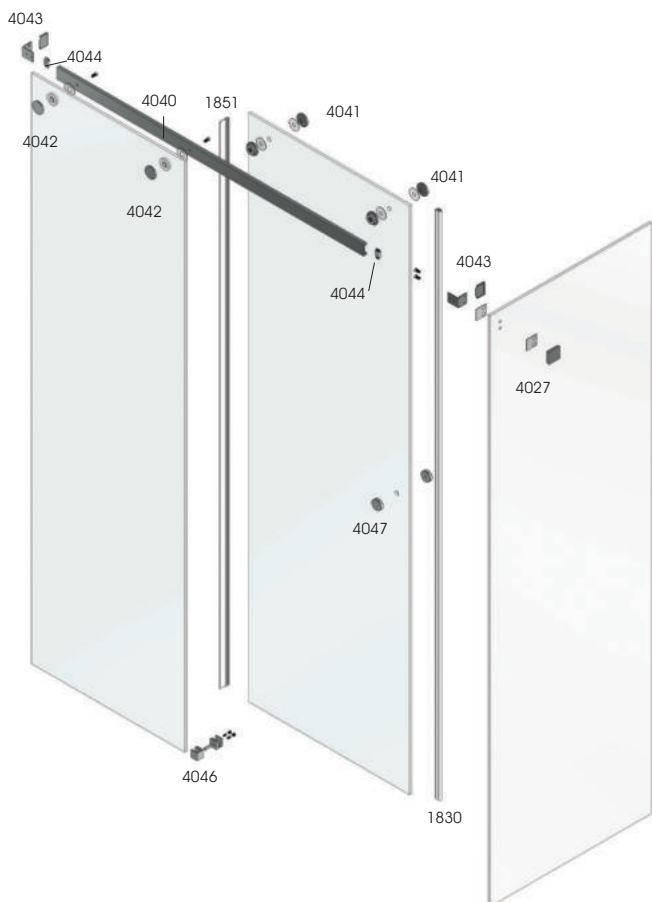
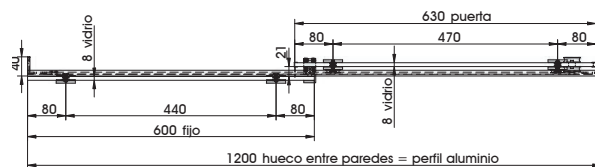
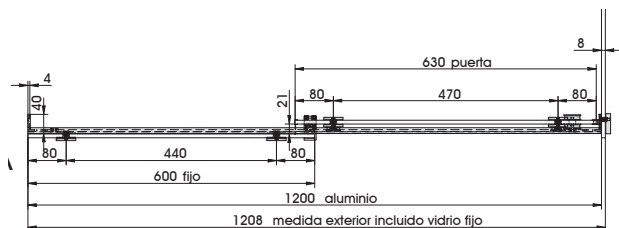
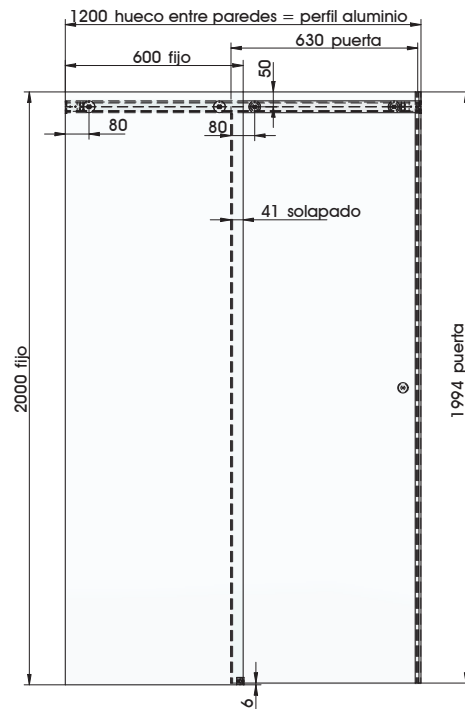
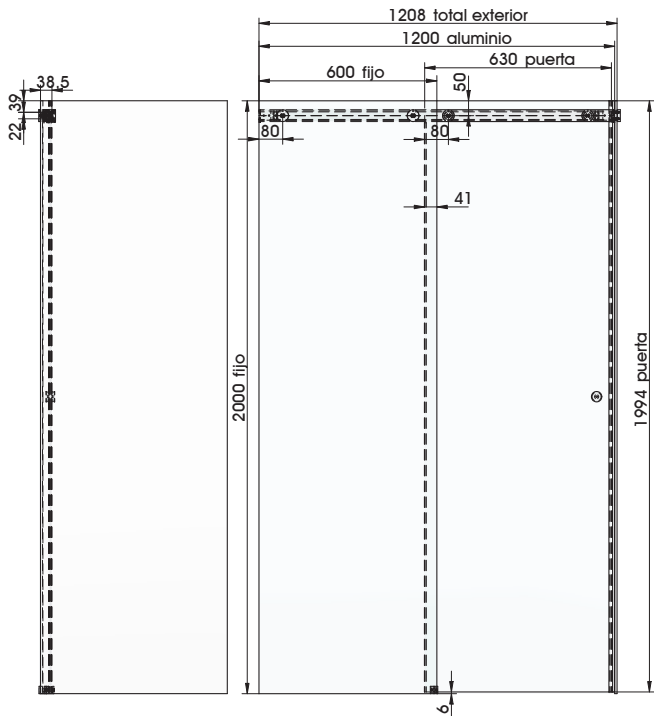

## COTEK - NEMO

CORREDERA PARA DUCHAS - COULISSANTS DOUCHE  
SCHOWER SLIDING DOOR - SCORREVOLI PER DOCCIA

### NEMO

- peso max: 40 kg/puerta (180° y 90°+fijo)
- peso max: 20 kg/puerta (2 puertas 90°)
- vidrio: 6-8 mm

- poids max: 40 kg/porte (180° et 90°+fixe)
- poids max: 20 kg/port (2 portes 90°)
- verre: 6-8 mm

- max weight: 40 kg/door (180° and 90°+fixed)
- max weight: 20 kg/door (2 doors 90°)
- glass: 6-8 mm

- peso max: 40 kg/porta (180° e 90°+fissjo)
- peso max: 20 kg/porta (2 porte 90°)
- vetro: 6-8 mm

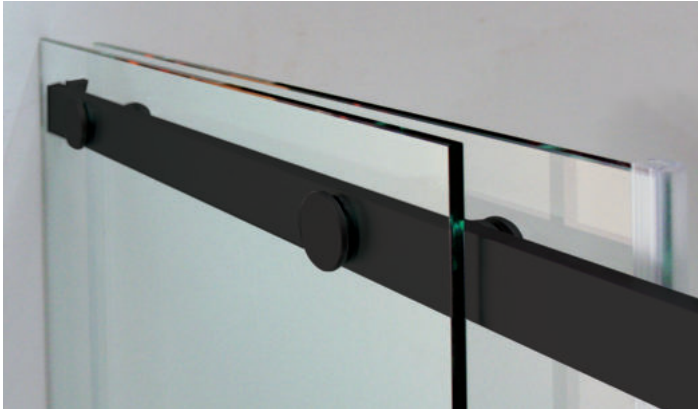

Corredera Nemo en acabado negro mate. Carril anodizado y componentes en latón en cromo negro.



Corredera Nemo con tapas embellecedoras cuadradas para aplicar a los cojinetes 4041 y a las fijaciones 4042.



Corredera Nemo en versión original con acabado brillo. Carril anodizado y componentes en latón en cromo brillo

## COTEK - NEMO

CORREDERA PARA DUCHAS - COULISSANTS DOUCHE  
SCHOWER SLIDING DOOR - SCORREVOLI PER DOCCIA

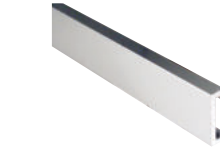

CARRIL  
COULISSE HAUTE  
UPPER TRACK  
GUIDA SUPERIORE  
4040/2..  
4040/3..

Ø40 mm



COJINETE  
CHARLOT  
ROLLER  
CUSCINETTO  
4041/0..

Ø40 mm



ANCLAJE VID.FIJO -CARRIL  
FIXATION VERRE-COULISSE  
CONNEXION GLASS-TRACK  
CONNEXIONE VETRO-GUIDA  
4042/0..



TAPA CUADRADA 4041/4042  
CARRÉ 4041/4042  
SQUARE COVER 4041/4042  
COPERTINA QUADRATA 4041/4042  
\*4041/T32

(no se venden por separado)



ANCLAJE CARRIL-PARED  
FIXATION MUR-COULISSE  
CONNEXION WALL-TRACK  
CONNEXIONE PARETE-GUIDA  
4043/0..



ANCLAJE CARRIL-PARED  
FIXATION MUR-COULISSE  
CONNEXION WALL-TRACK  
CONNEXIONE PARETE-GUIDA  
4050/0..



GUÍA SUELO  
GUIDAGE AU SOL  
FLOOR GUIDE  
GUIDA A PAVIMENTO  
4046/0..

## COTEK - NEMO 1 PUERTA + FIJO 90°

1 PORTE + 1 FIXE 90°  
1 DOOR + 1 FIXED 90°  
1 PORTA + 1 FISSO 90°



KIT 1 puerta + fijo 90° BASE

- 4040 2 m.
- 4041 2 u.
- 4042 2 u.
- 4043 2 u.
- 4027 1 u.
- 4044 2 u.
- 4046 1 u.
- 4047 1 u.
- 1851/109 2,2 m (8 mm)

4026/B...

KIT 1 puerta + fijo 90° + U

- 4040 2 m.
- 4041 2 u.
- 4042 2 u.
- 4043 2 u.
- 4027 1 u.
- 4044 2 u.
- 4046 1 u.
- 4047 1 u.
- 4376 o 1657 6 m
- 1851/109 2,2 m (8 mm)
- 1830/109 2,2 m (6-8 mm)

4026/U..

HASTA 200 CM  
VIDRIO 8 MM

Nemo "Cuadrado" se añadirán 4 tapas 4041/T32 para enganchar a las piezas 4041 (2 u.) y 4042 (2 u.)



KIT 1 puerta + fijo 90° + 4108

- 4040 2 m
- 4041 2 u.
- 4042 2 u.
- 4043 2 u.
- 4027 1 u.
- 4044 2 u.
- 4046 1 u.
- 4047 1 u.
- 4108 4 u.
- 1851/109 2,2 m (8 mm)
- 1830/109 2,2 m (6-8 mm)

4026/M..

NO incluidos:  
1831/202

PL. BR ALU. BR ALL. LUC	CR. BRILLO CH. POLI BR. CHR CR. LUC.	NEGRO NOIR BLACK NERO
02	32	0N
Al	2/3 m	40x12
∅6 mm	∇10 mm	€/u
o		o
o		o
Cu	20 kg/u	6-8 mm
∅ 21 mm		€/u
	o	o
Cu	6-8 mm	€/u
∅ 14-15 mm		€/u
	o	o
ABS	∞ 4041/4042	€/u
	*o	
Cu		€/u
	o	o
Cu		€/u
	o	o
Cu	6-10 mm	€/u
	o	o
CR. BRILLO CH. POLI BR. CHR CR. LUC.	CUADRO CARRÉ SQUARE QUADRO	NEGRO NOIR BLACK NERO
32	T2	0N
		€/u
		€/u
		€/u
		€/u



## COTEK - NEMO

CORREDERA PARA DUCHAS - COULISSANTS DOUCHE  
SCHOWER SLIDING DOOR - SCORREVOLI PER DOCCIA



STOP INTERIOR CARRIL  
STOP CHARLOT  
STOP ROLLER  
STOP CUSCINETTO  
**4044/0..**



CONEXIÓN 90° CARRIL-VID. FLOJO  
FIXATION VERRE-COULISSE  
CONNEXION GLASS-TRACK  
CONNESSIONE VETRO-GUIDA  
**4027/0..**



POMO  
POIGNÉE  
KNOB  
POMO  
**4047/0..**



CONEXIÓN 90° CARRIL  
FIXATION VERRE-COULISSE 90°  
TRACKS CONNEXION 90°  
CONNESSIONE GUIDE 90°  
**4045/0..**



MORSETO VIDRIO-PARED  
FIXATION VERRE-MUR  
BRACKET GLASS-WALL  
MORSETTO VETRO-PARETE  
**4105/032**



MORSETO VIDRIO PARED  
FIXATION VERRE-MUR  
BRACKET GLASS-WALL  
MORSETTO VETRO-PARETE  
**4108/Z..**



'U' ALUMINIO  
U ALUMINIUM  
U ALLUMINIUM  
U ALLUMINIO  
**1659/10N** 15x15x1,5 mm  
**1657/10N** 12x12x1,5 mm

PLÁSTICO PLASTIQUE PLASTIC PLASTICA	CR. BRILLO CHR. POLI BR. CHR. CR. LUC.	NEGRO NOR BLACK NERO		
09	32	0N	Cu	€/u
			o	o
			Cu	€/u
			6-10 mm	€/u
			∅ 8 mm	
			o	o
			Cu	€/u
			6-10 mm	€/u
			∅ 10 mm	
			o	o
			Cu	€/u
			6-10 mm	€/u
			∅ 10 mm	
			o	o
			Cu	€/u
			8-12 mm	€/u
			∅ 16 mm	
			o	o
			Zn	€/u
			8-12 mm	€/u
			∅ 16 mm	
			o	o
			Al	€/m
			5 m	€/m
			max. 10 mm	
			o	o
			max. 8 mm	
			o	o
			CR. BRILLO CHR. POLI BR. CHR. CR. LUC.	
			CUADRO CARRÉ SQUARE QUADRO	
			NEGRO NOR BLACK NERO	
			32	T2
			0N	

## COTEK - NEMO

CORREDERA PARA DUCHAS - COULISSANTS DOUCHE  
SCHOWER SLIDING DOOR - SCORREVOLI PER DOCCIA



'U' INOX PULIDO  
U INOX POLI  
U POLISHED STAINLESS STEEL  
U INOX LUCIDO  
**4375/122** 15x15x1,5 mm  
**4376/122** 15x12x1,5x1 mm  
**4377/122** 25x15x25x1 mm

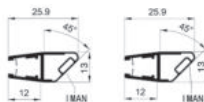

TAPAJUNTA CON IMÁN  
PROF. ÉTANCHÉITÉ MAGNÉTIQUE  
MAGNETIC SEAL  
GIUNTA MAGNETICA  
Set derecha + izquierda  
Set droite + gauche  
Set right + left  
Set destra + sinistra  
**1868/209** 8 mm  
**1866/209** 6 mm

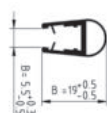

PERFIL MAMPARAS  
PROF. ÉTANCHÉITÉ  
SEAL  
GIUNTA  
**1830/109**

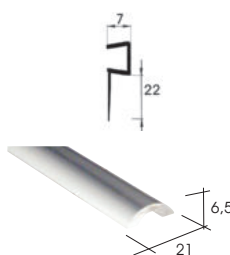

PERFIL LATERAL CORREDERA  
PROF. ÉTANCHÉITÉ COULISSE  
SLIDING DOOR SEAL  
GIUNTA PORTA SCORREVOLE  
**1851/109**

PERFIL BURLETE DE ALUMINIO  
PROFILE LEVRE-UO  
LIP-UP PROFILE  
PROFILO VERTICACQUE  
**1831/202**  
**1831/20N**

REMATE FINAL CARRIL  
BOUCHON COULISSE  
END-CAP TRACK  
COPRITESTA GUIDA SUPERIORE  
**\*4028/032**

CR. BRILLO CHR. POLI BR. CHR. CR. LUC.	INOX INOX P.S.S. INOX	PLÁSTICO PLASTIQUE PLASTIC PLASTICA		
32	22	09	inox s.s.	€/m
			3 m	
			max. 12 mm	
			max. 8 mm	
			max. 12 mm	
			pvc	€/m
			2,2 m	€/m
			6-8 mm	
			o	o
			pvc	€/m
			2,2 m	€/m
			6-8 mm	
			8 mm	€/m
			o	o
			Al	€/u
			2 m	€/u
			o	o
			NEGRO NOR BLACK NERO	
			0N	
			o	o
			Cu	€/u
			*o	
			CR. BRILLO CHR. POLI BR. CHR. CR. LUC.	
			CUADRO CARRÉ SQUARE QUADRO	
			NEGRO NOR BLACK NERO	
			32	T2
			0N	

## COTEK - NEMO 2 PUERTAS 90°

2 PORTES 90°  
2 DOORS 90°  
2 PORTE 90°



HASTA 100X100 CM  
VIDRIO 8 MM

Nemo "Cuadrado"  
se añadirán 8 tapas 4041/T32  
para enganchar a las piezas  
4041 (4 u.) y 4042 (4 u.)



### KIT 90° BASE

4040 2 m.  
4041 4 u.  
4042 4 u.  
4043 2 u.  
4045 1 u.  
4044 4 u.  
4046 2 u.  
4047 2 u.  
1851/109 4,4 m (8 mm)

### 4048/B..

### KIT 90° + U

4040 2 m.  
4041 4 u.  
4042 4 u.  
4043 2 u.  
4045 1 u.  
4044 4 u.  
4046 2 u.  
4047 2 u.  
4376 o 1657 6 m  
1851/109 4,4 m (8 mm)  
1828/109 2,2 m (6-8 mm)  
1829/109 2,2 m (6-8 mm)

### 4048/U..

### KIT 90° + 4108

4040 2 m.  
4041 4 u.  
4042 4 u.  
4043 2 u.  
4045 1 u.  
4044 4 u.  
4046 2 u.  
4047 2 u.  
4108 4 u.  
1851/109 4,4 m (8 mm)  
1828/109 2,2 m (6-8 mm)  
1829/109 2,2 m (6-8 mm)

### 4048/M..

NO incluidos:  
Burlete  
1831/202

## COTEK - NEMO 1 PUERTA 180°

1 PORTE 180°  
1 DOOR 180°  
1 PORTA 180°



HASTA 200 CM  
VIDRIO 8 MM

Nemo "Cuadrado"  
se añadirán 4 tapas 4041/T32  
para enganchar a las piezas  
4041 (2 u.) y 4042 (2 u.)



### KIT 180° BASE

4040 2 m.  
4041 2 u.  
4042 2 u.  
4043 2 u.  
4044 2 u.  
4046 1 u.  
4047 1 u.  
1851/109 2,2 m (8 mm)

### 4049/B..

### KIT 180° + U

4040 2 m.  
4041 2 u.  
4042 2 u.  
4043 2 u.  
4044 2 u.  
4046 1 u.  
4047 1 u.  
4376 o 1657 3 m  
1851/109 2,2 m (8 mm)  
1830/109 2,2 m (6-8 mm)

### 4049/U..

### KIT 180° + 4108

4040 2 m.  
4041 2 u.  
4042 2 u.  
4043 2 u.  
4044 2 u.  
4046 1 u.  
4047 1 u.  
4108 2 u.  
1851/109 2,2 m (8 mm)  
1830/109 2,2 m (6-8 mm)

NO incluidos:  
Burlete  
1831/202

**COTEK - \* QUADRO****QUADRO EJEMPLO DE APLICACIÓN****MAMPARA  
QUADRO**

Alta calidad  
Acabado negro  
anodizado

## COTEK - \* QUADRO



# COTEK - \* QUADRO

## POSIBLES APLICACIONES

PUERTA MÓVIL  
VIDRIO FIJO

### QUADRO 180°

DERECHA

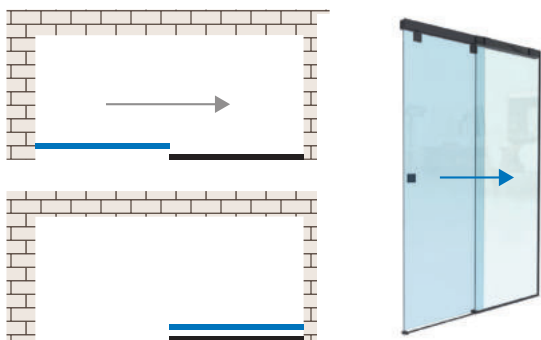

### QUADRO 90°

DERECHA

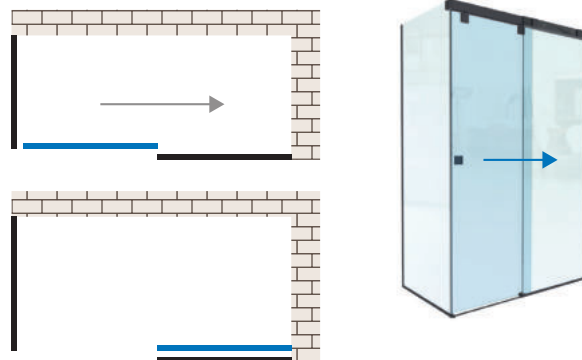

### QUADRO 180°

IZQUIERDA

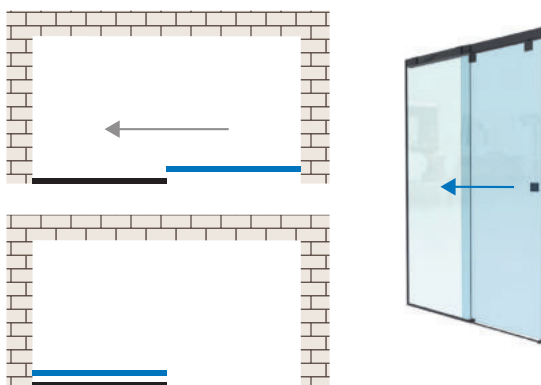

### QUADRO 90°

IZQUIERDA

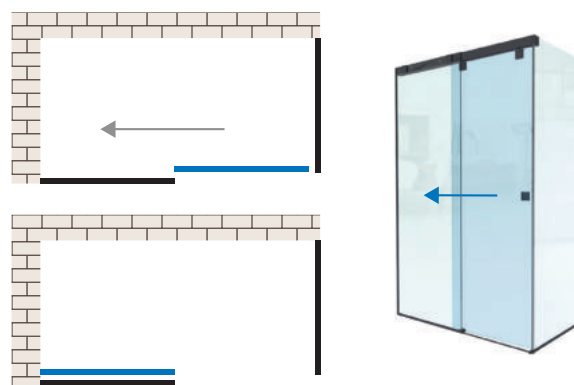

# COTEK - \* QUADRO

## DATOS GENERALES

### MATERIALES



#### VIDRIO

Puerta de vidrio /  
Marco en  
aluminio negro

Vidrio de 8 / 10 mm

### PESO



30 Kg max  
por cojinete

### CARACTERÍSTICAS

Deslizamiento suave  
Soft-closing en apertura y cierre  
Posibilidad de instalación  
en 180° o 90°

\* Disponible stock en acabado negro.  
Para otros acabados, consultar pedido  
mínimo y plazo de entrega.

### INSTALACIÓN 90°

\* Instalación igual que la  
de 180° añadiendo la  
segunda puerta fija a  
90°.

#### PUERTA FIJA 90° :

Sliding Glass / Fixed Glass



+

Fixed Glass 90°

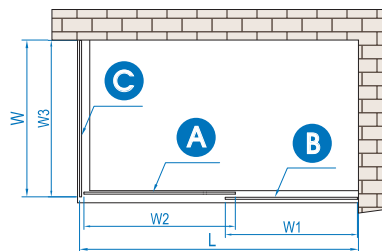
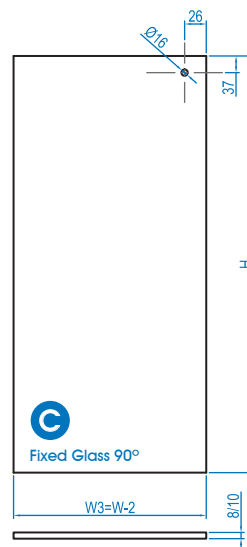

### INSTALACIÓN 180°

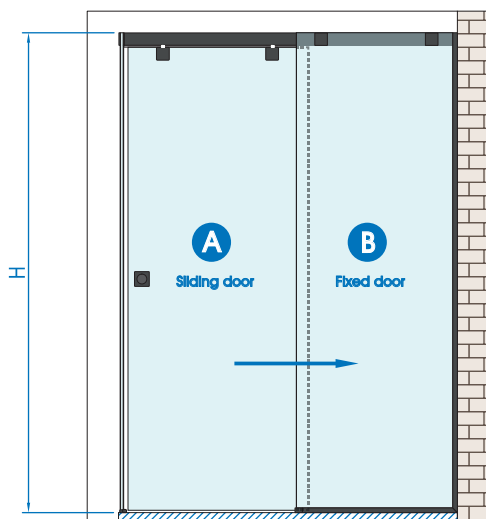
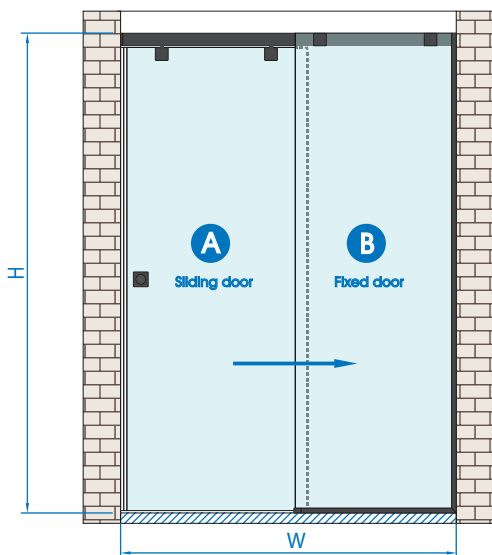
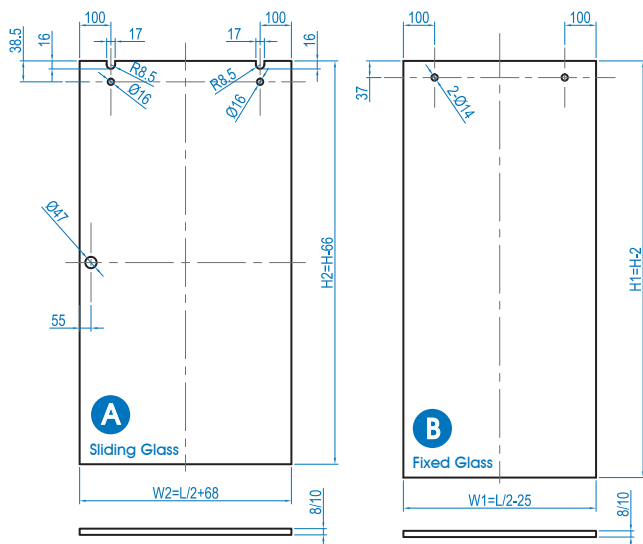

**COTEK -  
\* QUADRO**

**PIEZAS COMUNES**

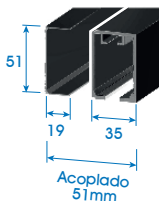

**CARRIL Y TAPA INTERIOR DE CARRIL**  
RAIL ET CHAPEAU DE RAIL  
RAIL AND RAIL CAP  
BINARIO E CAPPUCCIO DEL BINARIO  
**5510/25N**  
**5510/12N**

Al	8-10	€/u
	2450 mm	1225 mm

\* taladro para sujeción del fijo

○  
○

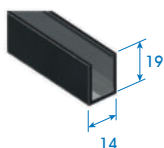

**"U" DE FIJACIÓN**  
FIXATION EN "U"  
"U" FIXING  
FISSAGGIO A "U"  
**5517/25N**

Al	2450mm	8-10	€/u
----	--------	------	-----

○

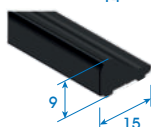

**PERFIL VIERTEAGUAS**  
RAIL DE GUIDAGE AU SOL  
FLOOR GUIDE RAIL  
BINARIO DI GUIDA A PAVIMENTO  
**5516/25N**  
**5516/12N**

Al	2450mm	1225mm	€/u
----	--------	--------	-----

○  
○

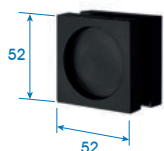

**UÑERO**  
POIGNÉE  
KNOB  
POMO  
**5518/00N**

Al	52x52mm	8-10	€/u
	∅47mm		

○

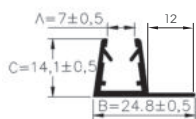

**PERFIL LATERAL CORREDERA**  
PROF. ÉTANCHEITE  
COULISSENT  
SLIDING DOOR SEAL  
GIUNTA PORTA  
SCORREVOLE  
**1855/109**

Pvc	2,2m	10	€/u
-----	------	----	-----

○

**KITS SOPORTES DE PUERTAS**

**KIT**

**F**  
x2  
REF.  
**5520/00N**



**E**  
x2  
REF.  
**5523/00N**



**H**  
x2  
REF.  
**5515/000**



**KIT: 2 COJINETES DE PUERTA MÓVIL + 2 ANCLAJES PARA FIJO + 2 BUFFERS (ASIMÉTRICOS)**  
KIT: 2 ROULEMENTS DE PORTE MOBILES + 2 ANCRAGES FIXES + 2 TAMPONS (ASYMÉTRIQUEUES)  
KIT: 2 MOVABLE DOOR BEARINGS + 2 FIXED ANCHORS + 2 BUFFERS (ASYMMETRIC)  
KIT: 2 CUSCINETTI PORTA MOBILI + 2 ANCORAGGI FISSI + 2 TAMPONI (ASIMMETRICI)  
**5532/00N** selfclosing

Al	51,5mm	8-10	€/u
	∅47mm		

○

**COTEK -  
\* QUADRO**

**KIT ACCESORIOS PARA 180° DER**

**KIT 180° DER**

**KIT DE TAPAS LATERALES DEL CARRIL SUPERIOR, Y GUIADOR Y TOPE DE SUELO**  
KIT DE CACHES LATÉRAUX DE RAIL SUPÉRIEUR, GUIDE ET BUTÉE AU SOL  
KIT OF TOP RAIL SIDE COVERS, AND GUIDE AND FLOOR STOP  
KIT COPERTURE LATÉRAU BINARIO SUPERIORE, GUIDA E BATTUTA A PAVIMENTO  
**5512/00N**

Al	5516 (5524-27)	5510 (5521-22)	€/u
----	----------------	----------------	-----

○

**G** x1  
REF.  
**5521/00N**



**G** x1  
REF.  
**5522/00N**



**H** x1  
REF.  
**5524/00N**



**I** x1  
REF.  
**5527/00N**



**KIT ACCESORIOS PARA 180° IZQ**

**KIT 180° IZQ**

**KIT DE TAPAS LATERALES DEL CARRIL SUPERIOR, Y GUIADOR Y TOPE DE SUELO**  
KIT DE CACHES LATÉRAUX DE RAIL SUPÉRIEUR, GUIDE ET BUTÉE AU SOL  
KIT OF TOP RAIL SIDE COVERS, AND GUIDE AND FLOOR STOP  
KIT COPERTURE LATÉRAU BINARIO SUPERIORE, GUIDA E BATTUTA A PAVIMENTO  
**5511/00N**

Al	5516 (5525-26)	5510 (5521-22)	€/u
----	----------------	----------------	-----

○

**G** x1  
REF.  
**5521/00N**



**G** x1  
REF.  
**5522/00N**



**H** x1  
REF.  
**5525/00N**



**I** x1  
REF.  
**5526/00N**



## COTEK - \* QUADRO

### KIT ACCESORIOS PARA 90° DER

**KIT**  
90°  
DER

*KIT DE TAPAS LATERALES DEL CARRIL SUPERIOR Y GUIADOR Y TOPE DE SUELO*  
*KIT DE CACHES LATÉRAUX DE RAIL SUPÉRIEUR, GUIDE ET BUTÉE AU SOL*  
*KIT OF TOP RAIL SIDE COVERS, AND GUIDE AND FLOOR STOP*  
*KIT COPERTURE LATÉRALI BINARIO SUPERIORE, GUIDA E BATTUTA A PAVIMENTO*  
5514/00N

AI 5516 (5524-29) 5510 (5522-31) €/U

G x1  
REF.  
5522/00N

G x1  
REF.  
5531/00N

H x1  
REF.  
5524/00N

I x1  
REF.  
5529/00N



### KIT ACCESORIOS PARA 90° IZQ

**KIT**  
90°  
IZQ

*KIT DE TAPAS LATERALES DEL CARRIL SUPERIOR Y GUIADOR Y TOPE DE SUELO*  
*KIT DE CACHES LATÉRAUX DE RAIL SUPÉRIEUR, GUIDE ET BUTÉE AU SOL*  
*KIT OF TOP RAIL SIDE COVERS, AND GUIDE AND FLOOR STOP*  
*KIT COPERTURE LATÉRALI BINARIO SUPERIORE, GUIDA E BATTUTA A PAVIMENTO*  
5513/00N

AI 5516 (5525-28) 5510 (5521-30) €/U

G x1  
REF.  
5521/00N

G x1  
REF.  
5530/00N

H x1  
REF.  
5525/00N

I x1  
REF.  
5528/00N



NEGRO  
NOIR  
BLACK  
NERO  
ON

## COTEK - \* QUADRO

### PACKS MAMPARA COMPLETA

**180°  
DER.**



COMPONENTES

X1	5510/25N o 5510/12N	KIT CARRIL 2450 MM
X1	5517/25N	5535/25N
X1	5516/25N o 5516/12N	
X1	5518/00N OPCIONAL	KIT CARRIL 1220 MM
X1	5532/00N	5535/12N
X1	5512/00N	

**180°  
IZQ.**



COMPONENTES

X1	5510/25N o 5510/12N	KIT CARRIL 2450 MM
X1	5517/25N	5536/25N
X1	5516/25N o 5516/12N	
X1	5518/00N OPCIONAL	KIT CARRIL 1220 MM
X1	5532/00N	5536/12N
X1	5511/00N	

**90°  
DER.**



COMPONENTES

X1	5510/25N o 5510/12N	KIT CARRIL 2450 MM
X1	5517/25N	5537/25N
X1	5516/25N o 5516/12N	
X1	5518/00N OPCIONAL	KIT CARRIL 1220 MM
X1	5532/00N	5537/12N
X1	5514/00N	

**90°  
IZQ.**



COMPONENTES

X1	5510/25N o 5510/12N	KIT CARRIL 2450 MM
X1	5517/25N	5538/25N
X1	5516/25N o 5516/12N	
X1	5518/00N OPCIONAL	KIT CARRIL 1220 MM
X1	5532/00N	5538/12N
X1	5513/00N	

NEGRO  
NOIR  
BLACK  
NERO  
ON

# COTEK - OSLO

CORREDERA PARA DUCHAS - COULISSANTS DOUCHE  
 SCHOWER SLIDING DOOR - SCORREVOLI PER DOCCIA

## OSLO

- peso max: 40 kg/puerta
- vidrio: 8-10 mm

- poids max: 40 kg/porte
- verre: 8-10 mm

- max weight: 40 kg/door
- glass: 8-10 mm

- peso max: 40 kg/porta
- vetro: 8-10 mm

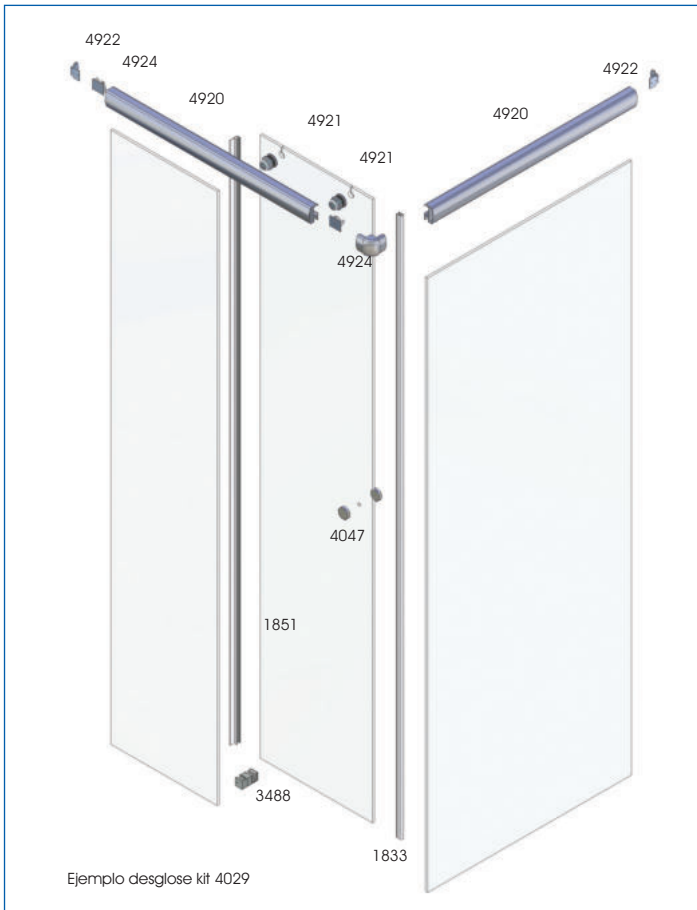
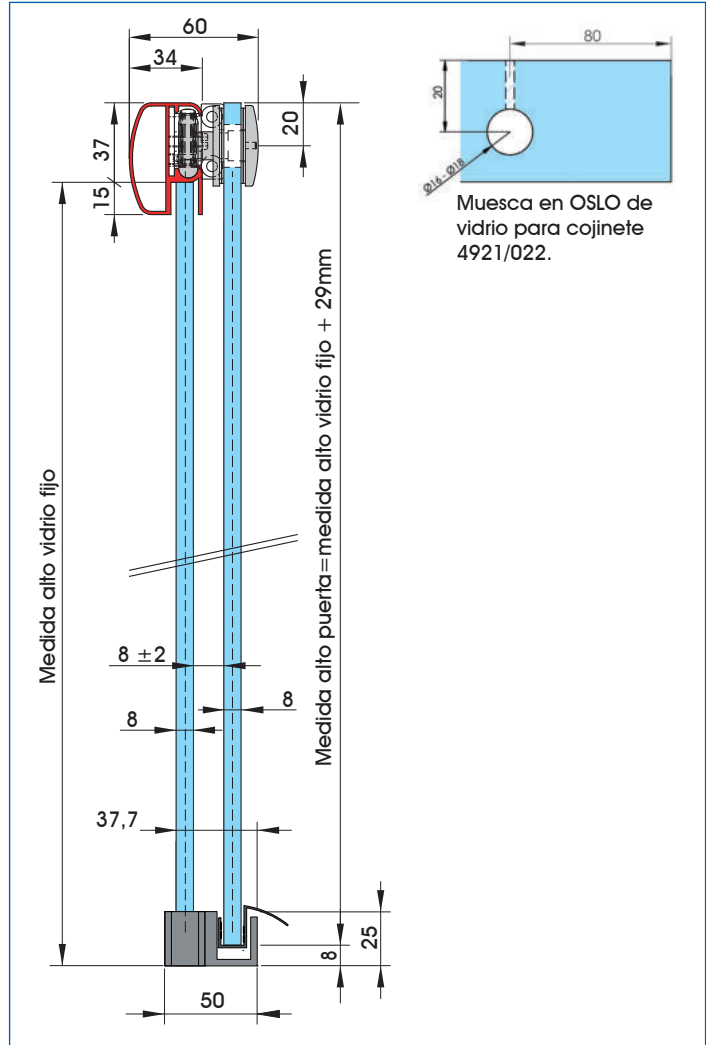
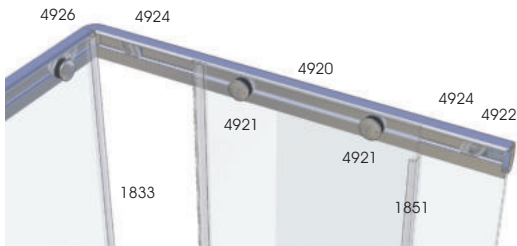

## COTEK - OSLO

1 PORTE + 1 FIXE 90°  
 1 DOOR + 1 FIXED 90°  
 1 PORTA + 1 FISSO 90°

1 PUERTA + FIJO 90°

CR. BRILLO  
 CR. POL.  
 BR. CR.  
 CR. LUC.

32



### KIT 1 puerta + fijo 90° BASE

Kit compuesto por:  
 4920/202 2 m.  
 4921/022 2 u.  
 4922/022 2 u.  
 4926/032 1 u.  
 4924/009 2 u.  
 3488/022 1 u.  
 4047/032 1 u.  
 1856/109 1 m.  
 1852/209 1 u. (8-10 mm)  
**4929/B32**

### KIT 90° BASE + U INOX

4376/122 6 m (8 mm)  
 1833/109 2,2 m  
**4929/U32**

### KIT 90° BASE + 4105

4105/032 4 u.  
 1833/109 2,2 m  
**4929/M32**

NO incluidos:  
 Burlete  
 1831/202

€/u



€/u



€/u





## COTEK - OSLO

CORREDERA PARA DUCHAS - COULISSANTS DOUCHE  
SCHOWER SLIDING DOOR - SCORREVOLI PER DOCCIA

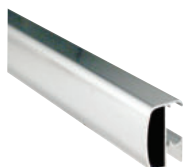

**CARRIL**  
COULISSE HAUTE  
UPPER TRACK  
GUIDA SUPERIORE  
4920/202

Próximamente  
nuevo diseño



**COJINETE**  
CHARLOT  
ROLLER  
CUSCINETTO  
4921/022

Próximamente  
nuevo diseño



**ANCLAJE CARRIL-PARED**  
FIXATION MUR-COULISSE  
CONNEXION WALL-TRACK  
CONNESSIONE PARETE-GUIDA  
4922/022



**STOP INTERIOR CARRIL**  
STOP CHARLOT  
STOP ROLLER  
STOP CUSCINETTO  
4924/009



**GUÍA SUELO VIDRIO**  
GUIDAGE AU SOL VERRE  
FLOOR GUIDE GLASS  
GUIDA A PAVIMENTO VETRO  
3488/022

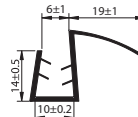

**PERFIL INFERIOR**  
PROF. ÉTANCHEITÉ  
SEAL  
GIUNTA  
1856/109



**GUÍA SUELO**  
GUIDAGE AU SOL  
FLOOR GUIDE  
GUIDA A PAVIMENTO  
\*4333/009



**UÑERO**  
POIGNÉE  
KNOB  
POMO  
\*4917/032



**POMO**  
POIGNÉE  
KNOB  
POMO  
4047/032

CR. BRILLO	PL. BR	INOX BR	PLÁSTICO
CH. POLI	ALU. BR	INOX POLI	PLÁSTICO
BR. CHR	ALU. BR	P.S.S.	PLÁSTICO
CR. LUC.	ALL. LUC	INOX LUC	PLÁSTICO
32	02	22	09
Al	2 m	34x52	€/u
8-10 mm			
		o	
Cu	20 kg/u	8-10mm	€/u
∅ 15 mm			
		o	
inox s.s.			€/u
		o	
inox s.s.			€/u
		o	
inox s.s.	10 mm	∞ 1856	€/u
		o	
pvc	8-10 mm	∞ 3488	€/m
		o	
pla	8-12 mm		€/u
		*o	
Al	8-10 mm	∅ 46 mm	€/u
		*o	
Cu	8-12 mm	∅ 16 mm	€/u
		o	

## COTEK - OSLO

CORREDERA PARA DUCHAS - COULISSANTS DOUCHE  
SCHOWER SLIDING DOOR - SCORREVOLI PER DOCCIA



**CONEXIÓN 90° CARRIL**  
FIXATION COULISSE 90°  
TRACKS CONNEXION 90°  
CONNESSIONE GUIDE 90°  
\*4926/032



**"U" INOX PULIDO**  
U INOX POLI  
U POL. STAINLESS STEEL  
U INOX LUCIDO  
15x15x15x1 mm  
4375/122  
15x12x15x1 mm  
4376/122  
25x15x25x1 mm  
4377/122



**MORSETO VIDRIO-PARED**  
FIXATION VERRE-MUR  
BRACKET GLASS-WALL  
MORSETTO VETRO-PARETE  
4105/032

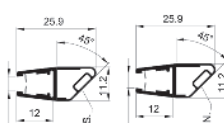

**CONJUNTO DE TAPAJUNTAS**  
DER./IZQ. CON IMÁN  
PROF. ÉTANCHEITÉ MAGNET.  
MAGNETIC SEAL  
GIUNTA MAGNETICA  
Set derecha + izquierda  
Set droite + gauche  
Set right + left  
Set destra + sinistra  
1866/209 8 mm  
1867/209 10 mm

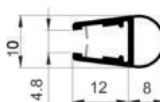

**PERFIL MAMPARAS**  
PROF. ÉTANCHEITÉ  
SEAL  
GIUNTA  
1833/109

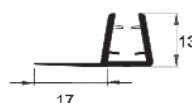

**PERFIL LATERAL CORREDERA**  
PROF. ÉTANCHEITÉ COULISSANT  
SLIDING DOOR SEAL  
GIUNTA PORTA SCORREVOLE  
1852/209 8 mm  
1853/209 10 mm



**PERFIL BURLETE**  
PROFILE LEVRE-UO  
LIP-UP PROFILE  
PROFILO VERTIACQUE  
1831/202

CR. BRILLO	PL. BR	INOX BR	PLÁSTICO
CH. POLI	ALU. BR	INOX POLI	PLÁSTICO
BR. CHR	ALU. BR	P.S.S.	PLÁSTICO
CR. LUC.	ALL. LUC	INOX LUC	PLÁSTICO
32	02	22	09
plas			€/u
		*o	
inox s.s.	3 m		€/m
		max. 12 mm	
		o	
		max. 8 mm	
		o	
		max. 12 mm	
		o	
Cu	8-12 mm	∅ 16 mm	€/u
		o	
pvc	2,2 m	8-10mm	€/u
		o	
pvc	2,2 m	8-10mm	€/m
		o	
pvc	2,2 m	8-10 mm	€/u
		o	
Al	2 m	21x6,5	€/u
		o	

## COTEK - OSLO

2 PUERTAS 90°  
2 DOORS 90°  
2 PORTE 90°



### KIT 90° BASE

Kit compuesto por:  
4920/202 2 m.  
4921/022 4 u.  
4922/022 2 u.  
4926/032 1 u.  
4924/009 4 u.  
3488/022 2 u.  
4047/032 2 u.  
1856/109 2 m. (8-10 mm)  
1852/209 1 u. (8-10 mm)  
4927/B32

### KIT 90° BASE

+ U INOX  
4376/122 6 m (8 mm)  
4927/U32

### KIT 90° BASE

+ 4105  
4105/032 4 u.  
4927/M32

NO incluidos:  
Burllete  
1831/202  
1866/209 1 u. (8 mm)  
1867/209 1 u. (10 mm)

CR. BRILLO  
CH. POLI  
BR. CHR  
CR. LUC.  
32

## COTEK - OSLO

1 PUERTA 180°  
1 DOOR 180°  
1 PORTAE 180°



### KIT 180° BASE

Kit compuesto por:  
4920/202 2 m.  
4921/022 2 u.  
4922/022 2 u.  
4924/009 2 u.  
3488/022 1 u.  
4047/032 1 u.  
1856/109 1 m. (8-10 mm)  
1852/209 1 u. (8-10 mm)  
4928/B32

### KIT 180° BASE

+ U INOX  
4376/122 3 m (8 mm)  
1833/109 2,2 m (8-10mm)  
4928/U32

### KIT 90° BASE

+ 4105  
4105/032 2 u.  
1833/109 2,2 m (8-10mm)  
4928/M32

NO incluidos:  
Burllete  
1831/202

CR. BRILLO  
CH. POLI  
BR. CHR  
CR. LUC.  
32

# COTEK - \* TURIN

CORREDERA PARA DUCHAS - COULISSANTS DOUCHE  
SCHOWER SLIDING DOOR - SCORREVOLI PER DOCCIA

## TURIN

- peso max: 40 kg/puerta
- vidrio: 8-10 mm

- poids max: 40 kg/porte
- verre: 8-10 mm

- max weight: 40 kg/door
- glass: 8-10 mm

- peso max: 40 kg/porta
- vetro: 8-10 mm

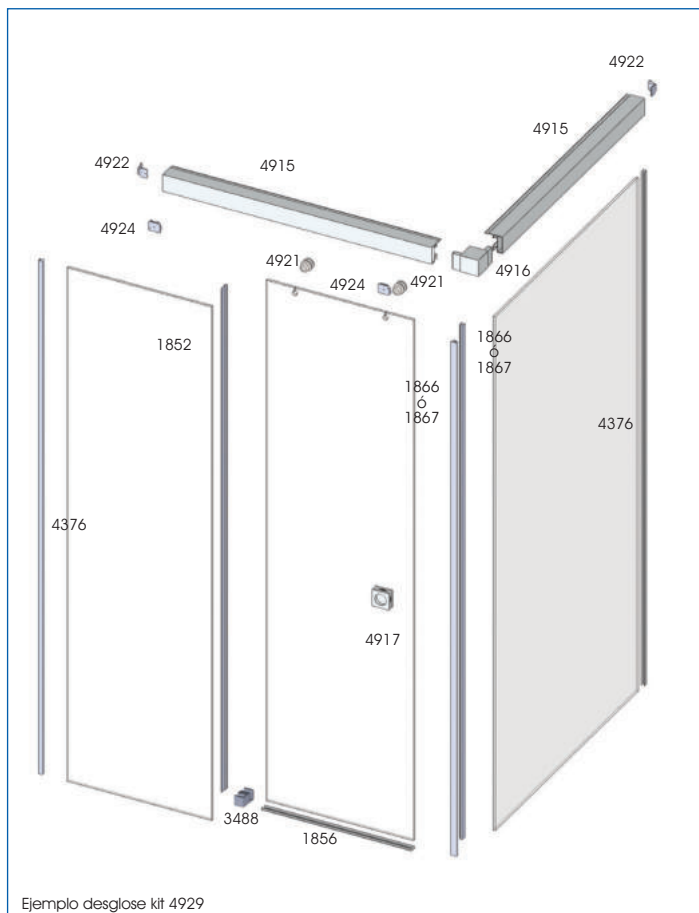
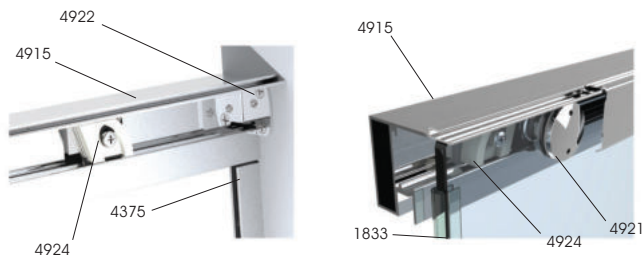
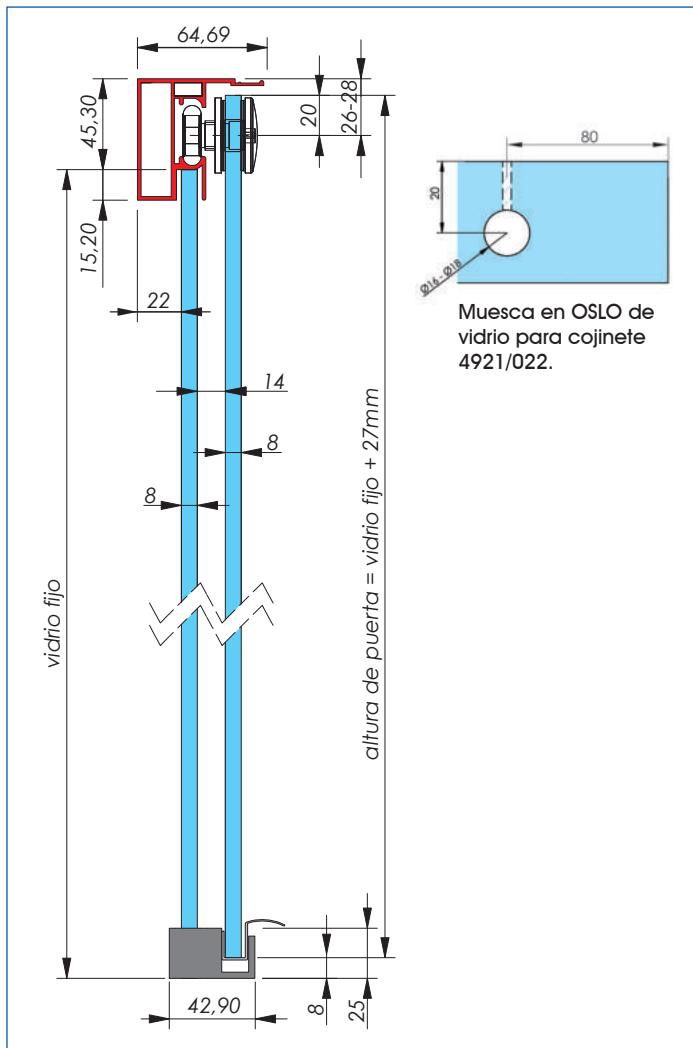

Ejemplo desglose kit 4929

## COTEK - \* TURIN

- 1 PUERTA + FIJO 90°
- 1 PORTE + 1 FIXE 90°
- 1 DOOR + 1 FIXED 90°
- 1 PORTA + 1 FISSO 90°



### KIT 90° BASE

- Kit compuesto por:
- 4915/202 1 u.
  - 4921/022 2 u.
  - 4922/022 2 u.
  - 4924/009 2 u.
  - 3488/032 1 u.
  - 1856/109 1 m.
  - 4916/032 1 u.
  - 4917/032 1 u.
  - 1852/209 1 u. (8-10 mm)

### 4919/B32

### KIT 90° BASE

- + U INOX
- 4376/122 6m (8 mm)
  - 1833/109 2,2m (8-10 mm)

### 4919/U32

### KIT 90° BASE

- + U ALUMINIO
- 1670/202 2 u.
  - 1671/209 2 u. (8 mm)
  - 1833/109 2,2m (8-10 mm)

### 4919/A32

### NO incluidos:

- Burlete
- 1831/202
- 1867/209
- 1866/209

CR. BRILLO  
CR. POLI  
BR. CR.  
CR. LUC.

32

€/U



€/U



€/U



# COTEK - \* TURIN

CORREDERA PARA DUCHAS - COULISSANTS DOUCHE  
SCHOWER SLIDING DOOR - SCORREVOLI PER DOCCIA

CR. BRILLO CH-R. POLI BR. CHR CR. LUC.	PL. BR ALU. BR ALL. LUC.	INOX. BR INOX. POLI P.S.S. INOX. LUC.	PLÁSTICO PLASTIQUE PLASTIC PLASTICA
32	02	22	09
Al	2 m	61x63	€/u
8-10 mm		ON	
		o	o
Cu	20 kg/u	8-10 mm	€/u
∅ 15 mm			o
inox s.s.			€/u
			o
inox s.s.			€/u
			o
inox s.s.			€/u
			o
inox s.s.	10 mm	∞ 1856	€/u
			o
pvc	8-10 mm	∞ 3488	€/m
			o
pla	8-12 mm		€/u
			o
Al	8-10 mm	∞ ∅ 46 mm	€/u
		ON	
		o	o
Cu	8-12 mm	∞ ∅ 16 mm	€/u
		ON	
		o	o

Próximamente nuevo diseño

Próximamente nuevo diseño

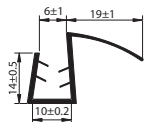

# COTEK - \* TURIN

CORREDERA PARA DUCHAS - COULISSANTS DOUCHE  
SCHOWER SLIDING DOOR - SCORREVOLI PER DOCCIA

CR. BRILLO CH-R. POLI BR. CHR CR. LUC.	PL. BR ALU. BR ALL. LUC.	INOX. BR INOX. POLI P.S.S. INOX. LUC.	PLÁSTICO PLASTIQUE PLASTIC PLASTICA
32	02	22	09
plac			€/u
			o
inox s.s.	3 m		€/m
			max. 12 mm
			max. 8 mm
			max. 12 mm
Al	2,1 m	36x22 mm	€/u
∞ 1671-1672		ON	
			o
Pla	2,1 m	8 mm	∞ 1670 €/u
			1671/209
Pla	2,1 m	6 mm	∞ 1670 €/u
			1672/209
pvc	2,2 m	8-10 mm	€/u
			o
pvc	2,2 m	8-10 mm	€/m
			o
pvc	2,2 m	8-10 mm	€/m
			o
pvc	2,2 m	8-10 mm	€/u
			o
Al	2 m	21x6,5	€/u
			ON
			o



CONEXIÓN 90º CARRIL  
FIXATION COULISSE 90º  
TRACKS CONNEXION 90º  
CONNESIONE GUIDE 90º

\*4916/032

"U" INOX PULIDO  
U INOX POLI  
U POL. STAINLESS STEEL  
U INOX LUCIDO  
15x15x15x1 mm

4375/122

15x12x15x1 mm

4376/122

25x15x25x1 mm

4377/122

"U" ALUMINIO, REGULABLE

"U" ALUMINIUM, RÉGLABLE

"U" ALUMINIUM, ADJUSTABLE

"U" DI ALUMINIO, REGOLABILE

Perfil de aluminio a pared

1670/202

1670/20N

Junta vidrio 8 mm

1671/209

Junta vidrio 6 mm

1672/209

CONJUNTO DE TAPA JUNTAS

DER. / IZQ. CON IMÁN

PROF. ÉTANCHEITÉ MAGNET.

MAGNETIC SEAL

GIUNTA MAGNETICA

Set derecha + izquierda

Set droite + gauche

Set right + left

Set destra + sinistra

1866/209 8 mm

1867/209 10 mm

PERFIL MAMPARAS

PROF. ÉTANCHEITÉ

SEAL

GIUNTA

1833/109

PERFIL LATERAL CORREDERA

PROF. ÉTANCHEITÉ COULISSANT

SLIDING DOOR SEAL

GIUNTA PORTA SCORREVOLE

1852/209 8 mm

1853/209 10 mm

PERFIL BURLETE

PROFILE LEVRE-UO

LIP-UP PROFILE

PROFILO VERTIACQUE

1831/202

1831/20N

TAPA SUPERIOR Y TACOS  
PARED INCLUIDOS EN KIT

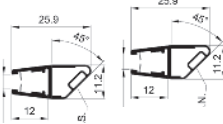

# COTEK - \* TURIN 2 PUERTAS 90º

2 PORTES 90º  
2 DOORS 90º  
2 PORTE 90º

CR. BRILLO  
CH-R. POLI  
BR. CHR  
CR. LUC.  
32



KIT 90º BASE

Kit compuesto por:  
4915/202 1 u.  
4921/022 4 u.  
4922/022 2 u.  
4924/009 4 u.  
3488/032 2 u.  
1856/109 2 m. (8-10 mm)  
4916/032 1 u.  
4917/032 2 u.  
1852/209 2 u. (8-10 mm)

4911/B32

KIT 90º BASE

+ U INOX  
4376/122 6m (8 mm)

4911/U32

KIT 90º BASE

+ U ALUMINIO  
1670/202 2 u.  
1671/209 2 u. (8 mm)

4911/A32

NO incluidos:

Burlete  
1831/202  
1866/209 1 u. (8 mm)  
1867/209 1 u. (10 mm)

# COTEK - \* TURIN 1 PUERTA 180º

1 PORTE 180º  
1 DOOR 180º  
1 PORTA 180º

CR. BRILLO  
CH-R. POLI  
BR. CHR  
CR. LUC.  
32



KIT 180º BASE

Kit compuesto por:  
4915/202 1 u.  
4921/022 2 u.  
4922/022 2 u.  
4924/009 2 u.  
3488/032 1 u.  
1856/109 1 m. (8-10 mm)  
4917/002 1 u.  
1852/209 1 u. (8-10 mm)

4918/B32

KIT 180º BASE

+ U INOX  
4376/122 3m (8 mm)  
1833/109 2,2m (8-10 mm)

4918/U32

KIT 180º BASE

+ U ALUMINIO  
1670/202 1 u.  
1671/209 1 u. (8 mm)  
1833/109 2,2 m (8-10 mm)

4918/A32

NO incluidos:

Burlete  
1831/202

# COTEK - VERONA

CORREDERA PARA DUCHAS - COULISSANTS DOUCHE  
SCHOWER SLIDING DOOR - SCORREVOLI PER DOCCIA

## VERONA

- peso max: 40 kg/puerta
- vidrio templado: 8mm

- poids max: 40 kg/porte
- verre trempé: 8-10 mm
- max weight: 40 kg/door
- tempered glass: 8-10 mm
- peso max: 40 kg/porta
- vetro temperato: 8-10 mm

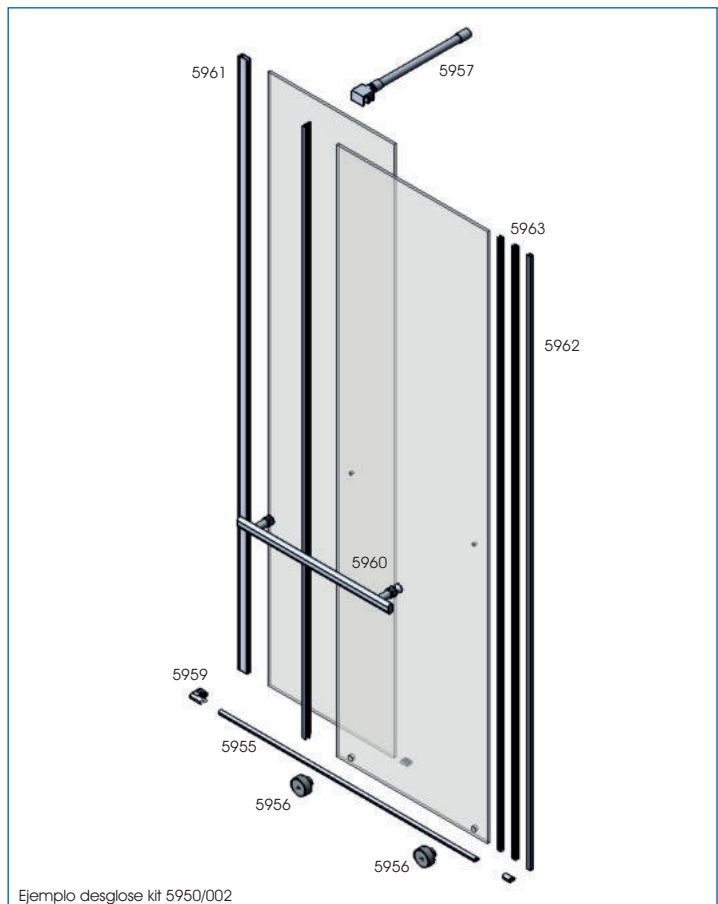
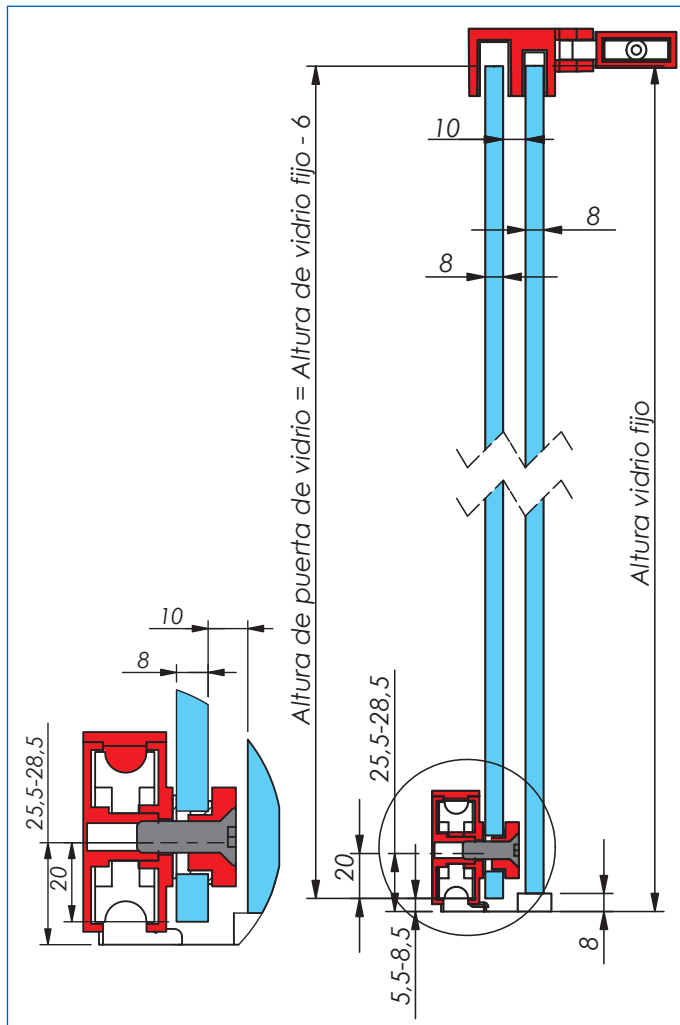

Ejemplo desglose kit 5950/002

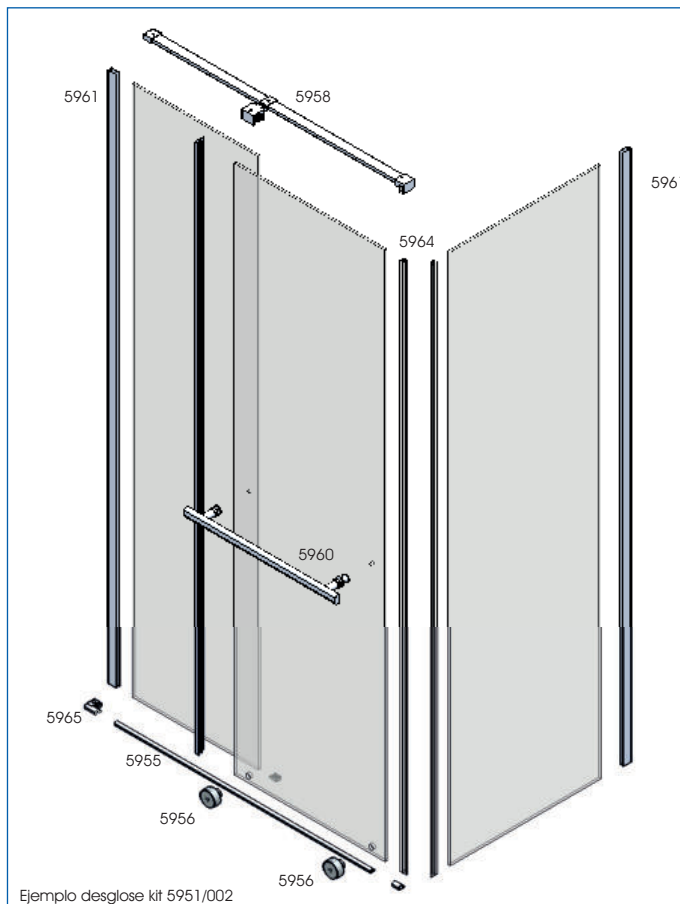

Ejemplo desglose kit 5951/002

# COTEK - VERONA

CORREDERA PARA DUCHAS - COULISSANTS DOUCHE  
SCHOWER SLIDING DOOR - SCORREVOLI PER DOCCIA

CR. BRILLO	PL. BR	INOX. BR	PLÁSTICO
CH. POLI	ALU. BR	INOX. POLI	PLÁSTICO
BR. CH.	ALU. BR	P.S.S.	PLÁSTICO
CR. LUC.	ALL. LUC.	INOX. LUC.	PLÁSTICO
32	02	22	09
Al	2 m	€ / u	
	o		
Cu	20 kg/u	8 mm	€ / u
	∅ 15 mm		
	o		
Zn	inox. s.s.	8 mm	€ / u
	o		
Zn	inox. s.s.	8 mm	1,2 m € / u
	o		
ABS	8 mm	€ / u	
	o		
Zn	inox. s.s.	6-10 mm	€ / u
	2 x ∅ 8 mm	CC= 440 mm	
	o		
Cu	8-12 mm	∅ 16 mm	€ / u
	o		
Al	1,95 m	8 mm	€ / u
	o		
Al	1,95 m	8 mm	€ / u
	o		
pvc	2 m	8 mm	€ / u
	o		
pvc	2 m	8 mm	€ / u
	o		



CARRIL  
COULISSE HAUTE  
UPPER TRACK  
GUIDA SUPERIORE  
5955/202



COJINETE  
CHARLOT  
ROLLER  
CUSCINETTO  
5956/032



GUÍA SUPERIOR + BARRA  
REFUERZO 90° VIDRIO FIJO  
GUIDAGE SUPERIEUR +  
BARRRE RENFORT 90°  
UPPER GUIDE + FIXING  
BAR WALL-GLASS 90°  
GUIDA SUPERIORE + BARRA  
RINFORZO 90° VETRO FISSO  
5957/032



GUÍA SUPERIOR + BARRA  
REFUERZO 180° VIDRIO FIJO  
GUIDAGE SUPERIEUR +  
BARRRE RENFORT 180°  
UPPER GUIDE + FIXING  
BAR WALL-GLASS 180°  
GUIDA SUPERIORE + BARRA  
RINFORZO 180° VETRO FISSO  
5958/032



SET STOP + FIJACIÓN INFERIOR  
VIDRIO FIJO + REMATE FINAL CARRIL  
SET STOP + FIXATION INFERIEUR  
VERRE FIXE + FINITION COULISSE  
SET STOPS + FIXING GLASS BOTTOM  
+ TRACK EMBELLISHER  
SET STOPS + FISSAGGIO INFERIORE  
VETRO FISSO + COPRITESTA  
5959/032 x kit 5950  
5965/032 x kit 5951



TIRADOR TOALLERO  
BARRA RECTANGULAR  
MANILLA + TOALLERO  
POIGNÉE + SERVIETTE  
HANDLE WITH TOWEL BAR  
MANIGLIONE CON PORTA  
ASCIUGAMANO  
5960/032

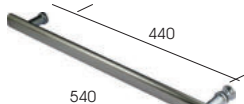

POMO  
POIGNÉE  
KNOB  
POMO  
4047/032



"U" ALUMINIO PARED  
"U" ALUMINIUM MUR  
"U" ALUMINIUM WALL  
"U" DI ALLUMINIO PARETE  
Vidrio de 8 mm  
5961/202



PERFALUM. X TAPAJUNTAS  
ALUM. PROF. ÉTANCHÉITÉ  
ALUM. PROF. SEAL  
PROF. ALLUMINIO, GIUNTA  
5962/202



KIT TAPAJUNTAS  
PROF. ÉTANCHÉITÉ  
SEAL  
GIUNTA  
5963/209 x kit 5950



KIT TAPAJUNTAS  
PROF. ÉTANCHÉITÉ  
SEAL  
GIUNTA  
5964/209 x kit 5951

# COTEK - VERONA

CORREDERA PARA DUCHAS - COULISSANTS DOUCHE  
SCHOWER SLIDING DOOR - SCORREVOLI PER DOCCIA

PL. BR	ALU. BR	INOX. BR	PLÁSTICO
ALL. LUC.	ALL. LUC.	INOX. LUC.	PLÁSTICO

## VERONA

### Mampara ducha rodamiento a suelo

Aluminio anodizado brillo  
Peso max: 40 kg/puerta  
Vidrio: 8 mm



### 5950/002 KIT CORREDERA + FIJO 180° ANCHO MÁXIMO 1200 mm

Kit compuesto por	
5955/202	1 u
5956/032	2 u
5957/032	1 u
5959/032	1 set
5960/032	1 u
5961/202	1 u
5962/202	1 u
5963/209	1 set



### 5951/002 KIT CORREDERA + FIJO 90° ANCHO MÁXIMO 1200 mm

Kit compuesto por	
5955/102	1 u
5956/032	2 u
5958/032	1 u
5965/032	1 set
5960/032	1 u
5961/202	2 u
5964/209	1 set

# COTEK - NICOLE

CORREDERA PARA DUCHAS - COULISSANTS DOUCHE  
SCHOWER SLIDING DOOR - SCORREVOLI PER DOCCIA

## NICOLE

- peso max: 50 kg/puerta (180° y 90°+ fijo)
- peso max: 25 kg/puerta (2 puertas 90°)
- vidrio puerta: 8-10 mm (max. 90 cm rec.)

- poids max: 50 kg/porte (180° et 90°+ fixe)
- poids max: 25 kg/porte (2 portes 90°)
- verre porte: 8-10 mm (max. 90 cm rec.)
- max weight: 50 kg/door (180° and 90°+ fixed)
- max weight: 25 kg/door (2 doors 90°)
- glass door: 8-10 mm (max. 90 cm rec.)

- peso max: 50 kg/porta (180° e 90°+ fisso)
- peso max: 25 kg/porta (12 porte 90°)
- vetro porta: 8-10 mm (max. 90 cm rec.)

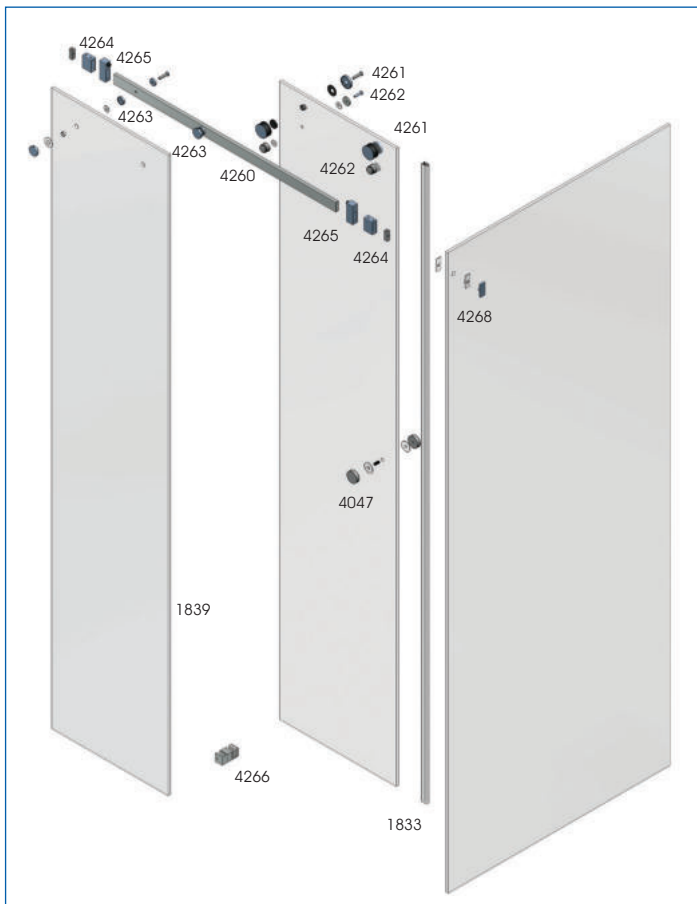
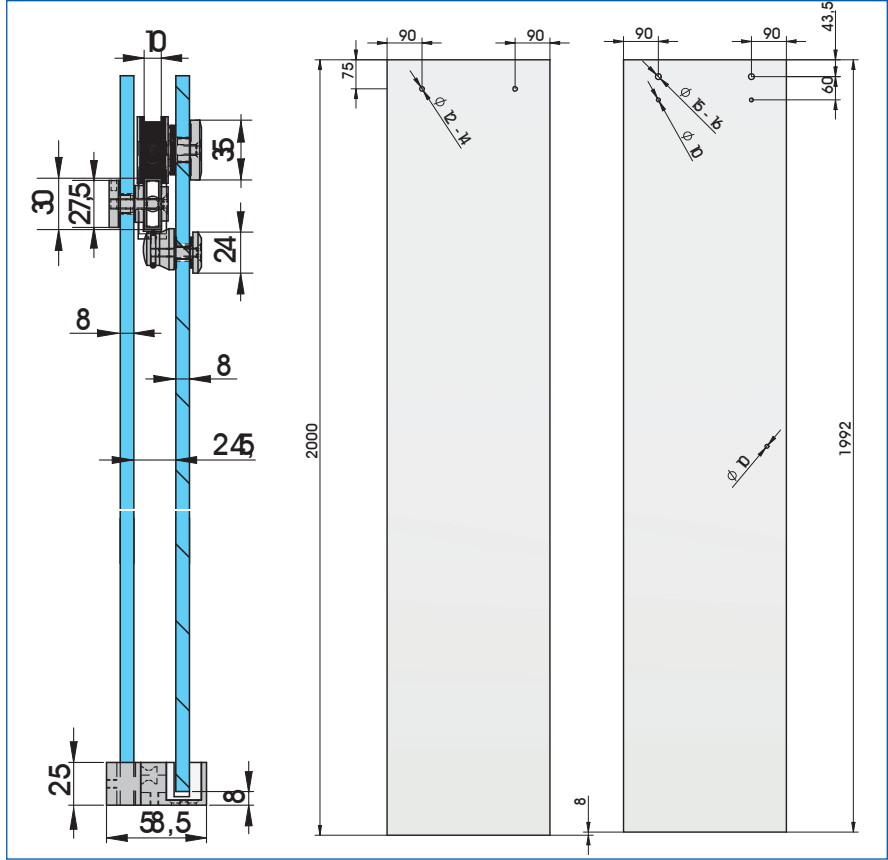

## COTEK - NICOLE 1 PUERTA + FIJO 90°

- 1 PORTE + 1 FIXE 90°
- 1 DOOR + 1 FIXED 90°
- 1 PORTA + 1 FISSO 90°

INOX BRILLO  
INOX POLI  
P. S. S.  
INOX LUCIDO

22

### KIT 1 puerta + fijo 90° BASE

- Kit compuesto por:
- 4260/122 2 m.
  - 4261/022 2 u.
  - 4262/022 2 u.
  - 4263/022 2 u.
  - 4266/022 1 u.
  - 4264/022 2 u.
  - 4265/022 2 u.
  - 4268/022 1 u.
  - 4047/032 1 u.
  - 1839/209 2,2 m (8 mm)

4272/B22

€/u

### KIT 1 puerta + fijo 90° BASE + U INOX

- 4260/122 2 m.
- 4261/022 2 u.
- 4262/022 2 u.
- 4263/022 2 u.
- 4266/022 1 u.
- 4264/022 2 u.
- 4265/022 2 u.
- 4268/022 1 u.
- 4047/032 1 u.
- 4376/122 6 m (8 mm)
- 1839/209 2,2 m (8 mm)
- 1833/109 2,2 m

4272/U22

€/u



HASTA 100X100 CM  
VIDRIO 8 MM

NO incluidos:  
Burlete  
1831/202

### COTEK - NICOLE

CORREDERA PARA DUCHAS - COULISSANTS DOUCHE  
SCHOWER SLIDING DOOR - SCORREVOLI PER DOCCIA



CARRIL  
COULISSE HAUTE  
UPPER TRACK  
GUIDA SUPERIORE  
4260/122



COJINETE  
CHARLOT  
ROLLER  
CUSCINETTO  
4261/022



TOPE SEGURIDAD  
ÉPINGLE DE SÛRETÉ  
SAFETY PIN  
PERNO DI SICUREZZA  
4262/022



ANCLAJE VID.FIJO - CARRIL  
FIXATION VERRE-COULISSE  
CONNEXION GLASS-TRACK  
CONNESSIONE VETRO-GUIDA  
4263/022



CONEXIÓN TUBO-PARED  
FIXATION TUBE-MUR  
CONNEXION TUBE-WALL  
CONNESSIONE TUBO-PARETE  
\*4269/022



ANCLAJE CARRIL-PARED  
FIXATION MUR-COULISSE  
CONNEXION WALL-TRACK  
CONNESSIONE PARETE-GUIDA  
4264/022



STOP INTERIOR CARRIL  
STOP CHARLOT  
STOP ROLLER  
STOP CUSCINETTO  
4265/022



GUÍA SUELO  
GUIDAGE AU SOL  
FLOOR GUIDE  
GUIDA A PAVIMENTO  
4266/022



CONEXIÓN 90° CARRIL  
FIXATION COULISSE 90°  
TRACKS CONNEXION 90°  
CONNESSIONE GUIDE 90°  
4267/022

INOX	BR	CP. BRILLO	PLÁSTICO	
INOX	POLI	CH-R. POLI	PLÁSTICO	
P.S.S.	INOX	CH-R.	PLÁSTICO	
INOX	LUC	CP. LUC.	PLÁSTICO	
22	32	09		
inox	s.s.	6 m	30x10x1,5	€/m
				o
inox	s.s.	8-10 mm	20kg/u	€/u
		15 mm		o
inox	s.s.	8-10 mm		€/u
		8 mm		o
inox	s.s.	8-10 mm		€/u
		15 mm		o
inox	s.s.			€/u
				*o
inox	s.s.			€/u
				o
inox	s.s.	8-10 mm		€/u
				o
inox	s.s.			€/u
				o

### COTEK - NICOLE

CORREDERA PARA DUCHAS - COULISSANTS DOUCHE  
SCHOWER SLIDING DOOR - SCORREVOLI PER DOCCIA



CONEXIÓN 90° CARRIL-VID. FIJO  
FIXATION VERRE-COULISSE  
CONNEXION GLASS-TRACK  
CONNESSIONE VETRO-GUIDA  
4268/022



REMATE FINAL CARRIL  
BOUCHON COULISSE  
END-CAP TRACK  
COPRITESTA TUBO  
\*4275/022



POMO  
POIGNÉE  
KNOB  
POMO  
4047/032



"U" INOX PULIDO  
U INOX POLI  
U POL. STAINLESS STEEL  
U INOX LUCIDO  
15x15x15x1 mm  
4375/122



15x12x15x1 mm  
4376/122  
25x15x25x1 mm  
4377/122

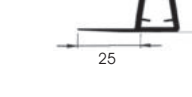

PERFIL LATERAL CORREDERA  
PROF. ÉTANCHÉITÉ COULISSANT  
SLIDING DOOR SEAL  
GIUNTA PORTA SCORREVOLE  
1839/209



CONJUNTO DE TAPA JUNTAS  
DER./IZQ. CON IMÁN  
PROF. ÉTANCHÉITÉ MAGNET.  
MAGNETIC SEAL  
GIUNTA MAGNETICA  
Set derecha + izquierda  
Set droite + gauche  
Set right + left  
Set destra + sinistra  
1866/209 8 mm  
1867/209 10 mm

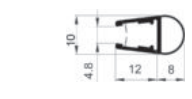

PERFIL MAMPARAS  
PROF. ÉTANCHÉITÉ  
SEAL  
GIUNTA  
1833/109



PERFIL BURLETE  
PROFILE LEVRE-VO  
LIP-UP PROFILE  
PROFILO VERTIACQUE  
1831/202

CP. BRILLO	PL. BR	INOX	BR	PLÁSTICO
CH-R. POLI	ALU. BR	INOX	POLI	PLÁSTICO
BR. CH-R.	ALU. BR	P.S.S.	INOX	PLÁSTICO
CP. LUC.	ALL. LUC	INOX	LUC	PLÁSTICO
32	02	22	09	
inox	s.s.	8-10 mm		€/u
		1210 mm		o
inox	s.s.			€/m
				*o
Cu		6-10 mm	10 mm	€/u
				o
inox	s.s.	L 3 m		€/m
				max. 12 mm
				o
				max. 8 mm
				o
				max. 12 mm
				o
pvc		2,2 m	8-10 mm	€/u
				o
pvc		2,2 m	8-10 mm	€/u
				o
				o
				o
pvc		2,2 m	8-10 mm	€/m
				o
Al		2 m	21x6,5	€/u
				o

### COTEK - NICOLE 2 PUERTAS 90°

2 PORTES 90°  
2 DOORS 90°  
2 PORTE 90°

INOX	BRILLO
INOX	POLI
P.S.S.	INOX
INOX	LUCIDO
22	



KIT 90° BASE  
Kit compuesto por:  
4260/122 2 m.  
4261/022 4 u.  
4262/022 4 u.  
4263/022 4 u.  
4266/022 2 u.  
4264/022 2 u.  
4265/022 4 u.  
4267/022 1 u.  
4047/032 2 u.  
1839/209 4,4 m (8 mm)  
4271/B22

KIT 90° BASE  
+ U INOX  
4260/122 2 m.  
4261/022 4 u.  
4262/022 4 u.  
4263/022 4 u.  
4266/022 2 u.  
4264/022 2 u.  
4265/022 4 u.  
4267/022 1 u.  
4047/032 2 u.  
4376/122 6 m (8 mm)  
1839/209 4,4 m (8 mm)  
4271/U22

NO incluidos:  
Burlete  
1831/202  
1866/209 2,2 m (8 mm)  
1867/209 2,2 m (10 mm)

HASTA 100X100 CM  
VIDRIO 8 MM

### COTEK - NICOLE 1 PUERTA 180°

1 PORTE 180°  
1 DOOR 180°  
1 PORTAE 180°

INOX	BRILLO
INOX	POLI
P.S.S.	INOX
INOX	LUCIDO
22	



KIT 180° BASE  
Kit compuesto por:  
4260/122 2 m.  
4261/022 2 u.  
4262/022 2 u.  
4263/022 2 u.  
4266/022 1 u.  
4264/022 2 u.  
4265/022 2 u.  
4047/032 1 u.  
1839/209 2,2 m (8 mm)  
4270/B22

KIT 180° BASE  
+ U INOX  
4260/122 2 m.  
4261/022 2 u.  
4262/022 2 u.  
4263/022 2 u.  
4266/022 1 u.  
4264/022 2 u.  
4265/022 2 u.  
4047/032 1 u.  
4376/122 3 m (8 mm)  
1839/209 2,2 m (8 mm)  
1833/109 2,2 m  
4270/U22

NO incluidos:  
Burlete  
1831/202

HASTA 200 CM  
VIDRIO 8 MM

# COTEK - KOBE 80 KG

PUERTAS CORREDERA CON AMORTIGUADOR - PORTES COULISSANTS AVEC AMORTISSEURS  
SLIDING DOORS WITH DUMPERS- PORTE SCORREVOLI CON AMORTIZZATORI

## KOBE DUCHA

- peso max puerta: 80 kg
- vidrio puerta: 8-10-12 mm
- sin muesca en el vidrio

- poids limite porte: 80 kg/porte
- verre 8-10-12mm
- sans encoches
- weight max door: 80 kg/door
- glass 8-10-12mm
- without cut-out
- peso max porta: 50 kg
- vetro 8-10-12mm
- senza tacca nel vetro

APLICACIÓN PARA DUCHA.  
PARA PUERTAS DE PASO  
VER PÁG. C59

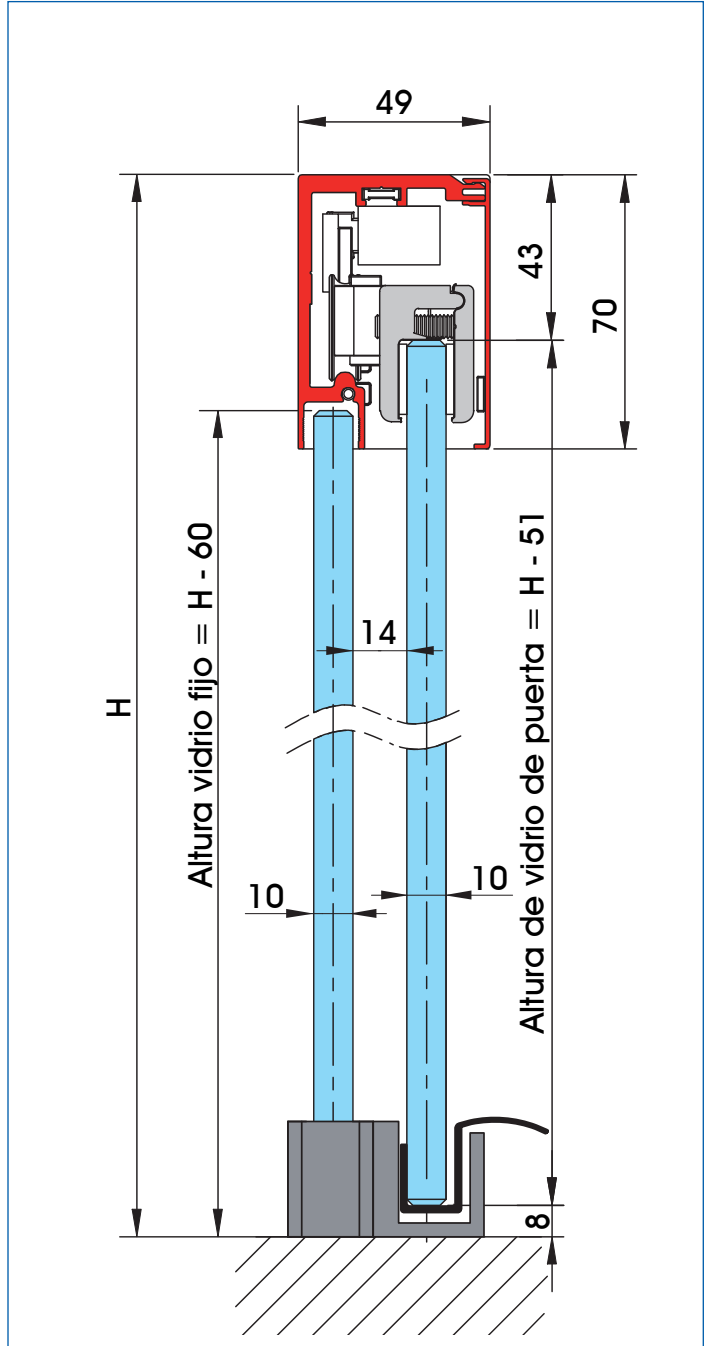
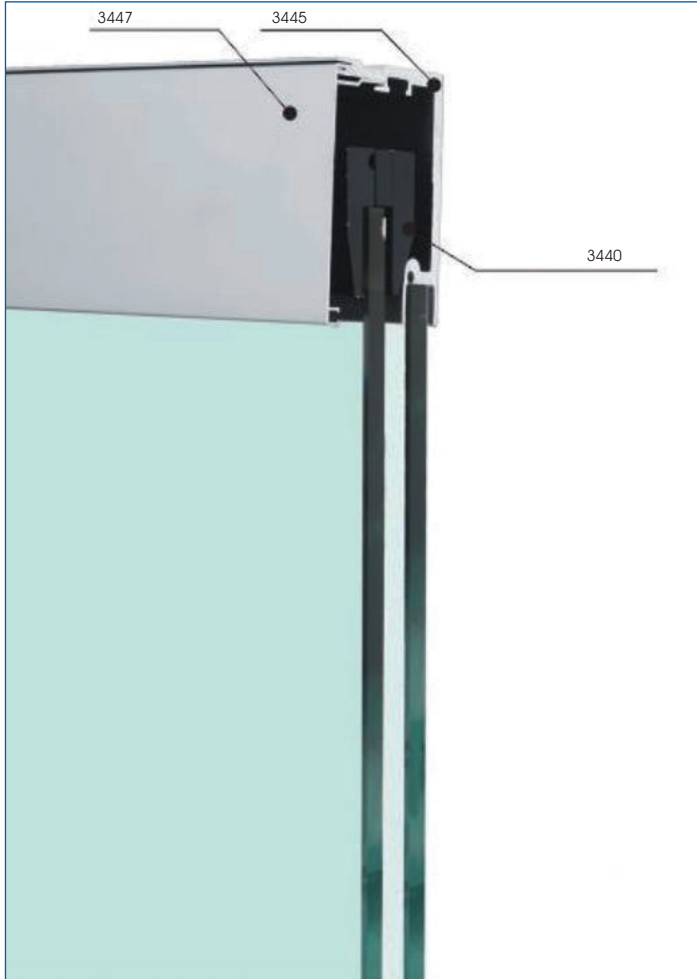



# COTEK - KOBE 80 KG

PUERTAS CORREDERA - PORTES COULISSANTS  
SLIDING DOORS - PORTE SCORREVOLI

PL. BR ALU. BR ALL. LUC	PL. M ALU. M ALL. NAT	INOX BR INOX POLI P.S.S. INOX LUC	PLÁSTICO PLASTIC PLASTIC PLASTICA
02	01	22	09



**CARRIL**  
**COULISSE HAUTE**  
**UPPER TRACK**  
**GUIDA SUPERIORE**  
**3445/201** 1,93 m  
**3445/301** 2,90 m  
**3445/501** 5,80 m

Al		5,8m	48x70	€/u
		10-12 mm		



**PERFIL TAPA CARRIL**  
**PROFIL COUVERTURE COULISSE**  
**TRACK COVER PROFIL**  
**PROFILO COPERTINA GUIDA**  
**3447/201** 1,93 m  
**3447/301** 2,90 m  
**3447/501** 5,80 m

Al		5,8m	76x22	€/u
----	--	------	-------	-----



**ANCLAJE CARRIL-PARED**  
**SUPPORT PROFIL-MUR**  
**SUPPORT PROFIL-WALL**  
**UNIONE PROFILO-PARETE**  
**3454/011** SET 2 PIEZAS

Al		30x30	∞ 3445	€/u
----	--	-------	--------	-----

PARA CARRIL AUTOPORTANTE



**PINZA PORTAVIDRIO**  
**PINCE POUR VERRE CLAM**  
**CON AMORTIGUADORES**  
**AVEC AMORTISSEURS**  
**WITH DUMPERS**  
**CON AMORTIZZATORI**  
**3440/001**

Al		80kg/2u.	140x35	€/u
		8-10-12 mm		



**GUÍA SUELO VIDRIO**  
**GUIDAGE AU SOL VERRE**  
**FLOOR GUIDE GLASS**  
**GUIDA A PAVIMENTO VETRO**  
**3488/022**

inox s.s.		10 mm	∞ 1856	€/u
-----------	--	-------	--------	-----

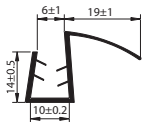

**PERFIL INFERIOR**  
**PROF ÉTANCHEITÉ**  
**SEAL**  
**GIUNTA**  
**1856/109**

pvc		8-10 mm	∞ 3488	€/m
-----	--	---------	--------	-----



**"U" INOX PULIDO**  
**U INOX POLI**  
**U POL. STAINLESS STEEL**  
**U INOX LUCIDO**  
**15x15x15x1 mm**  
**4375/122**  
**15x12x15x1mm**  
**4376/122**  
**25x15x25x1mm**  
**4377/122**

inox s.s.		3 m		€/m
-----------	--	-----	--	-----

# COTEK - KOBE 80 KG

PUERTAS CORREDERA - PORTES COULISSANTS  
SLIDING DOORS - PORTE SCORREVOLI

CR. BRILLO CH.R. POLI BR. CH CR. LUC.	PL. M ALU. M ALL. NAT	INOX BR INOX POLI P.S.S. INOX LUC	INOX SAT INOX SAT S.S.S. INOX SAT
32	01	22	28

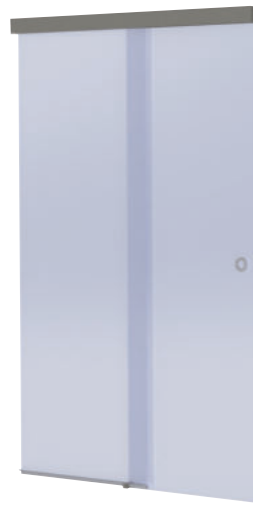

## MONTAJE A PARED LATERAL + VIDRIO FIJO

**KIT PORTE COULISSANTE FIXÉ AU MUR LATÉRAL + VERRE FIXE**  
**KIT SLIDING DOOR FIXED TO SIDE WALL + FIXED GLASS**  
**KIT PORTA SCORREVOLE FISSATO A LA PARETE LATERALE + VETRO FISSO**

**3453/D21** 1,93 m

**CON AMORTIGUADOR, AVEC AMORTISSEURS,**  
**WITH DUMPERS, CON AMORTIZZATORI**  
**3445/201** 1 u. carril  
**3447/201** 1 u. tapa carril  
**3440/001** 2 u. pinzas  
**3488/022** 1 u. "U" guía inferior  
**1856/109** 1 m. perfil inferior (10 mm)  
**4207/001** 1 u. uñero  
**3454/001** 2 u. anclaje carril-pared

**NO INCLUIDOS**  
1833/109  
1855/109  
4376/122

## MONTAJE A TECHO

**KIT PORTE COULISSANTE FIXÉ AU PLAFOND + VERRE FIXE**  
**KIT SLIDING DOOR FIXED TO THE CEILING + FIXED GLASS**  
**KIT PORTA SCORREVOLE A SOFFITTO + VETRO FISSO**

**3455/D21** 1,93 m

**CON AMORTIGUADOR, AVEC AMORTISSEURS,**  
**WITH DUMPERS, CON AMORTIZZATORI**  
**3445/201** 1 u. carril  
**3447/201** 1 u. tapa carril  
**3440/001** 2 u. pinzas  
**3488/022** 1 u. "U" guía inferior  
**1856/109** 1 m. perfil inferior (10 mm)  
**4207/001** 1 u. uñero

**NO INCLUIDOS**  
1833/109  
1855/109  
4376/122

## UÑEROS PUERTAS CORREDERAS



**UÑERO DOBLE ADHESIVO**  
**POIGNÉE DOUBLE ADHESIVE**  
**DOUBLE ADHESIVE PULL**  
**POMO DOPPIO ADHESIVO**  
**4207/0..**  
**4207/0..**

		∅ 60	€/u
--	--	------	-----

Al				
inox s.s.				



**GALGA MONTAJE UÑEROS**  
**GABARIT DE MONTAGE**  
**INSTALLATION TOOL**  
**SAGOMA AIUTO MONTAGGIO**  
**4209/000**

Al			€/u
----	--	--	-----

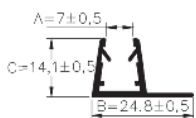

**PERFIL LATERAL**  
**PROF ÉTANCHEITÉ**  
**SEAL**  
**GIUNTA**  
**1855/109**

pvc	L 2,2m		10mm	€/m
-----	--------	--	------	-----

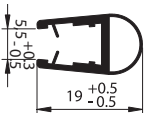

**PERFIL MAMPARAS**  
**PROF ÉTANCHEITÉ**  
**SEAL**  
**GIUNTA**  
**1833/109**

pvc	L 2,2m		8-10mm	€/m
-----	--------	--	--------	-----

# COTEK - ROMA QUADRANT

PUERTA VAIVÉN PARA DUCHAS - PORTE VA-ET -VIENT DOUCHE  
SCHOWER SWINGING DOORS - PORTA VA E VIENI PER DOCCIA

PLATA, BRILLO  
ALU. ANOD. BR  
ALU. ANOD. BR  
ALU. ANOD. LUC  
02

## ROMA QUADRANT

- aluminio acabado brillo
- peso max: 30 kg/puerta
- vidrio: 6 mm

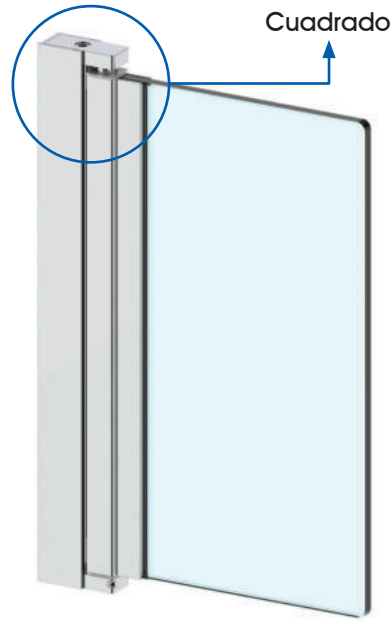

**ALTO TOTAL= 1900 mm**  
hauteur totale, total glass, altezza totale

**VIDRIO: 6 mm**  
verre, glass, vitrio

**ALTO VIDRIO= 1874 mm**  
hauteur verre, high glass, altezza vetro

**ANCHO MAX. = 900 mm**  
largeur max. = 900 mm  
max. width = 900 mm  
larghezza mass. = 900 mm

### CORTE ANTIGUO CONSULTAR

**ALTO TOTAL= 1950 mm**  
hauteur totale, total glass, altezza totale

**VIDRIO: 6 mm**  
verre, glass, vitrio

**ALTO VIDRIO= 1903 mm**  
hauteur verre, high glass, altezza vetro

**ANCHO MAX. = 900 mm**  
largeur max. = 900 mm  
max. width = 900 mm  
larghezza mass. = 900 mm

### CORTE NUEVO CONSULTAR

PUERTA VAIVÉN SIMPLE PARA PLATO DUCHA  
PORTE VA-ET-VIENT SIMPLE POUR DOUCHE  
SIMPLE SWINGING DOOR FOR SHOWER PLATE  
PORTA VA E VIENI SEMPLICE PER PIATTO DOCCIA  
VIDRIO NO INCLUIDO  
VERRE NON INCLUS, GLASS NOT INCLUDED, VETRO NO INCLUSO  
4948/002 1 puerta

Al  6 mm €/U

## Medidas corte vidrio ROMA QUADRANT

Consultar disponibilidad de los modelos Roma con perfil Quadrant  
Vérifier la disponibilité des modèles de Rome avec le profil Quadrant  
Check availability of Rome models with Quadrant profile  
Verifica la disponibilità dei modelli di Roma con il profilo Quadrant

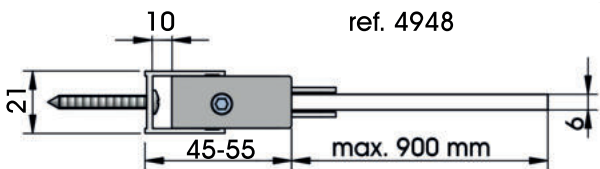
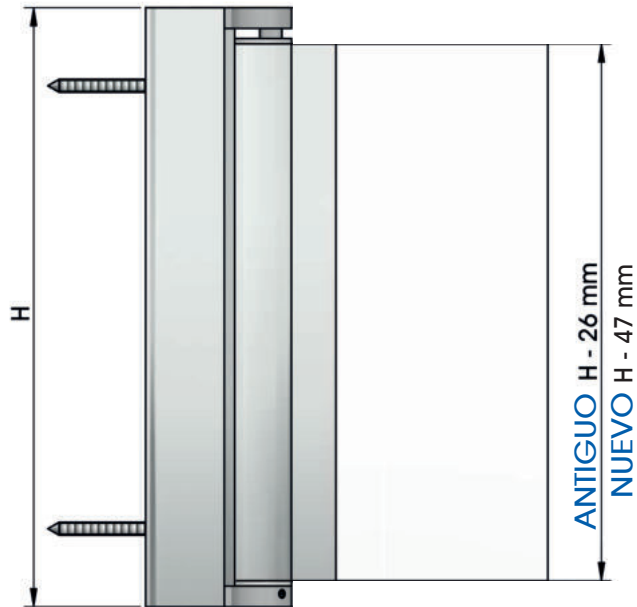

# COTEK - ROMA

PUERTA VAIVÉN PARA DUCHAS - PORTE VA-ET -VIENT DOUCHE  
SCHOWER SWINGING DOORS - PORTA VA E VIENI PER DOCCIA

PLATA, BRILLO  
ALU. ANOD. BR  
ALU. ANOD. BR  
ALU. ANOD. LUC  
02



**ALTO TOTAL= 1450 mm**  
1450 ó 1500 mm (consultar)

hauteur totale, total glass, altezza totale  
**VIDRIO: 6 mm**  
verre, glass, vitrio

**ALTO VIDRIO= -26 mm**  
hauteur verre, high glass, altezza vetro

**ANCHO MAX. = 900 mm**  
largeur max., max. width  
larghezza mass

### CORTE ANTIGUO CONSULTAR

**ALTO TOTAL= 1400 mm**  
hauteur totale, total glass, altezza totale  
**VIDRIO: 6 mm**  
verre, glass, vitrio

**ALTO VIDRIO= -47 mm**  
hauteur verre, high glass, altezza vetro

**ANCHO MAX. = 900 mm**  
largeur max., max. width  
larghezza mass

### CORTE NUEVO CONSULTAR

PUERTA BATIENTE SIMPLE PARA BAÑERA  
PORTE BATTANTE SIMPLE POUR BAIGNOIRE  
SIMPLE SWINGING DOOR FOR BATHTUB  
PORTA VA E VIENI SEMPLICE PER VASCA  
VIDRIO NO INCLUIDO  
VERRE NON INCLUS, GLASS NOT INCLUDED, VETRO NO INCLUSO  
4944/002

Al  6 mm €/U

**ALTO TOTAL= 1500 mm**  
hauteur totale, total glass, altezza totale

**VIDRIO: 6 mm**  
verre, glass, vitrio

**ALTO VIDRIO PUERTA= 1474 mm**  
hauteur verre porte, high door glass,  
altezza vetro porta

**ALTO VIDRIO FIJO= 1500 mm**  
hauteur verre fixe, high fixed glass,  
altezza vetro fisso

**ANCHO MAX. PUERTA= 800 mm**  
largeur max. porte= 800 mm  
max. width door = 800 mm  
larghezza mass. porta= 800 mm

**ANCHO MIN. FIJO= 500 mm**  
largeur min. porte= 500 mm  
min. width door = 500 mm  
larghezza min. porta= 500 mm

### CORTE ANTIGUO CONSULTAR

**ALTO TOTAL= 1400 mm**  
hauteur totale, total glass, altezza totale

**VIDRIO: 6 mm**  
verre, glass, vitrio

**ALTO VIDRIO PUERTA= 1353 mm**  
hauteur verre porte, high door glass,  
altezza vetro porta

**ALTO VIDRIO FIJO= 1400 mm**  
hauteur verre fixe, high fixed glass,  
altezza vetro fisso

**ANCHO MAX. PUERTA= 800 mm**  
largeur max. porte= 800 mm  
max. width door = 800 mm  
larghezza mass. porta= 800 mm

**ANCHO MIN. FIJO= 600 mm**  
largeur min. porte= 600 mm  
min. width door = 600 mm  
larghezza min. porta= 600 mm

### CORTE NUEVO CONSULTAR

FIJO + PUERTA BATIENTE PARA BAÑERA  
VERRE FIXE + PORTE BATTANTE POUR BAIGNOIRE  
FIXED GLASS + SWINGING DOOR FOR BATHTUB  
VETRO FISSO + PORTA VA E VIENI PER VASCA  
VIDRIO NO INCLUIDO  
VERRE NON INCLUS, GLASS NOT INCLUDED, VETRO NO INCLUSO  
4946/002

Al  6 mm €/U

BARRA REFUERZO 4167/032 PARED-VIDRIO 45° INCLUIDA  
BARRE RENFORT 4167/032 MUR-VERRE 45° INCLUS  
FIXING BAR 4167/032 WALL-GLASS 45° INCLUDED  
BARRA RINFORZO 4167/032 PARETE-VETRO 45° INCLUSA

## COTEK - ROMA

PUERTA VAIVÉN PARA DUCHAS - PORTE VA-ET-VIENT DOUCHE  
SCHOWER SWINGING DOORS - PORTA VA E VIENI PER DOCCIA

PLATA, BRILLO  
ALU. ANOD. BR  
ALU. ANOD. BR  
ALU. ANOD. LUC  
02



**ALTO TOTAL= 1900 mm**  
hauteur totale, total glass, altezza totale

**VIDRIO: 6 mm**  
verre, glass, vidrio

**ALTO VIDRIO= 1845 mm**  
hauteur verre, height glass, altezza vetro

**ANCHO MAX. = 900 mm**  
largeur max., max. width, larghezza mass.

**CORTE ANTIGUO**  
**CONSULTAR**

**ALTO TOTAL= 1950 mm**  
hauteur totale, total glass, altezza totale

**VIDRIO: 6 mm**  
verre, glass, vidrio

**ALTO VIDRIO= 1903 mm**  
hauteur verre, height glass, altezza vetro

**ANCHO MAX. = 900 mm**  
largeur max., max. width, larghezza mass.

**CORTE NUEVO**  
**CONSULTAR**

PUERTA VAIVÉN SIMPLE PARA PLATO DUCHA  
PORTE VA-ET-VIENT SIMPLE POUR DOUCHE  
SIMPLE SWINGING DOOR FOR SHOWER PLATE  
PORTA VA E VIENI SEMPLICE PER PIATTO DOCCIA  
VIDRIO NO INCLUIDO  
VERRE NON INCLUS, GLASS NOT INCLUDED, VETRO NO INCLUSO  
**4945/002 1 puerta**

Al 6 mm €/u

o

## COTEK - ROMA

PUERTA VAIVÉN PARA DUCHAS - PORTE VA-ET-VIENT DOUCHE  
SCHOWER SWINGING DOORS - PORTA VA E VIENI PER DOCCIA

### Medidas corte vidrio ROMA

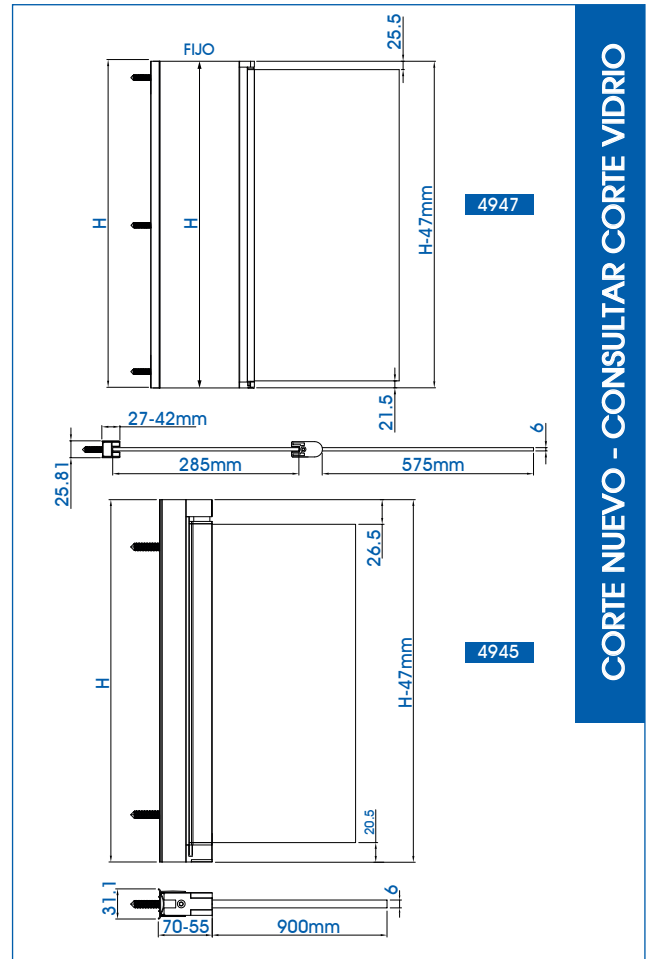

CORTE NUEVO - CONSULTAR CORTE VIDRIO

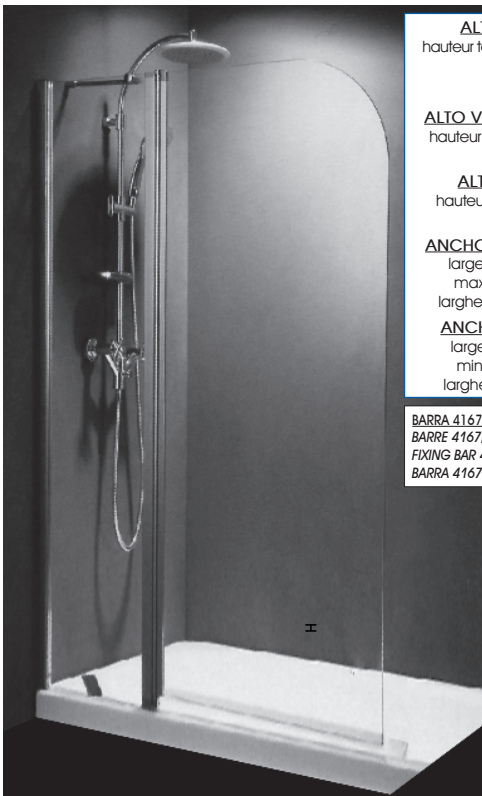

**ALTO TOTAL= 1950 mm**  
hauteur totale, total glass, altezza totale

**VIDRIO: 6 mm**  
verre, glass, vidrio

**ALTO VIDRIO PUERTA= 1903 mm**  
hauteur verre porte, height door glass, altezza vetro porta

**ALTO VIDRIO FIJO= 1950 mm**  
hauteur verre fixe, height fixed glass, altezza vetro fisso

**ANCHO MAX. PUERTA= 900 mm**  
largeur max. porte= 800 mm  
max. width door = 800 mm  
larghezza mass. porta= 800 mm

**ANCHO MIN. FIJO= 500 mm**  
largeur min. porte= 500 mm  
min. width door = 500 mm  
larghezza min. porta= 500 mm

BARRA 4167/032 PARED-VIDRIO 45° INCLUIDA  
BARRA 4167/032 MUR-VERRE 45° INCLUS  
FIXING BAR 4167/032 WALL-GLASS 45° INCLUDED  
BARRA 4167/032 PARETE-VETRO 45° INCLUSA

FIJO + PUERTA BATIENTE PARA DUCHA  
VERRE FIXE + PORTE VA-ET-VIENT POUR DOUCHE  
FIXED GLASS + SWINGING DOOR FOR SHOWER PLATE  
VETRO FISSO + PORTA VA E VIENI PER DOCCIA  
VIDRIO NO INCLUIDO  
VERRE NON INCLUS, GLASS NOT INCLUDED, VETRO NO INCLUSO  
**4947/002 1 puerta**

Al 6 mm €/u

o

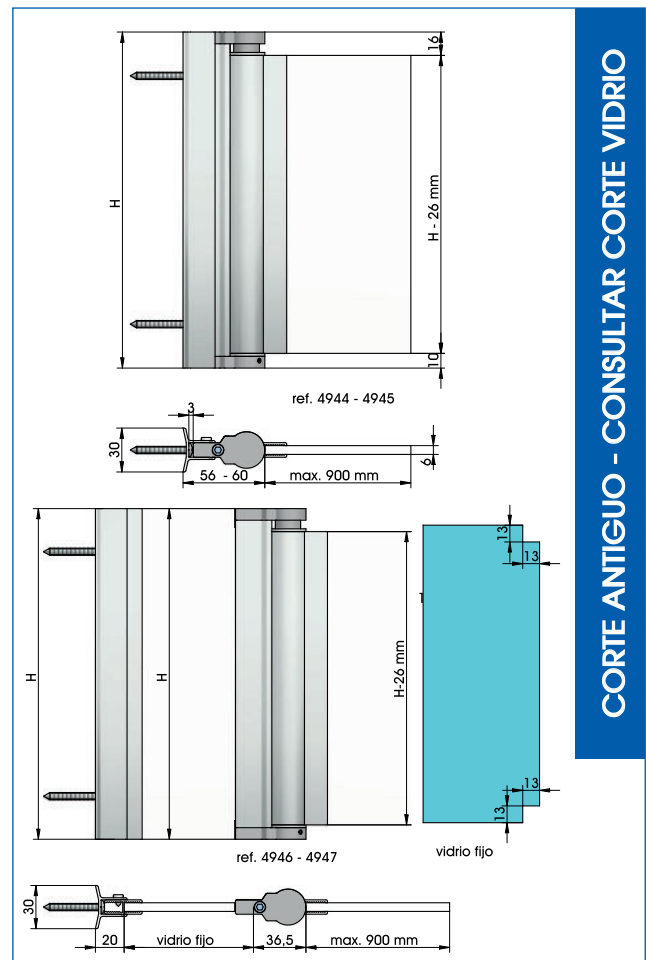

CORTE ANTIGUO - CONSULTAR CORTE VIDRIO

# COTEK

HERRAJES PARA DUCHAS - ACCESSOIRES DE DOUCHE  
SCHOWER GLASS FITTINGS - ACCESSORI PER DOCCIA

CP. BRILLO CHR. POLI BR. CHR CP. LUC.	INOX BR INOX POLI P.S.S. INOX LUC	TITAN TITANIO TITANIO	INOX SAT INOX SAT S.S.S. INOX SAT
32	22	06	28

## TEIDE 6/8



**BISAGRA PARED-VIDRIO**  
CHARNIÈRE MUR-VERRE  
HINGE WALL-GLASS  
CERNIERA PARETE-VERTO

4180/0.. latón

4180/Z32 zamak

**BISAGRA DESPLAZADA PARED-VIDRIO**  
CHARNIÈRE MUR-VERRE DESPLACÉE  
HINGE WALL-GLASS OFFSET  
CERNIERA PARETE-VERTO ALA SPOSTATA

4184/0.. latón

4184/Z32 zamak

**BISAGRA VIDRIO-VIDRIO 180°**  
CHARNIÈRE VERRE-VERRE 180°  
HINGE GLASS-GLASS 180°  
CERNIERA VETRO-VETRO 180°

4181/0.. latón

4181/Z32 zamak

**BISAGRA VIDRIO-VIDRIO 90°**  
CHARNIÈRE VERRE-VERRE 90°  
HINGE GLASS-GLASS 90°  
CERNIERA VETRO-VETRO 90°

4182/032

**BISAGRA VIDRIO-VIDRIO 135°**  
CHARNIÈRE VERRE-VERRE 135°  
HINGE GLASS-GLASS 135°  
CERNIERA VETRO-VETRO 135°

4183/032

Cu		80x50 mm	€/u
	6-8 mm	18 kg/u	0°-90°-180°
Cu	<input type="radio"/>	<input type="radio"/>	<input type="radio"/>
Zn	<input type="radio"/>	<input type="radio"/>	<input type="radio"/>
Cu		80x50 mm	€/u
	6-8 mm	18 kg/u	0°-90°-180°
Cu	<input type="radio"/>	<input type="radio"/>	<input type="radio"/>
Zn	<input type="radio"/>	<input type="radio"/>	<input type="radio"/>
Cu		80x50 mm	€/u
	6-8 mm	18 kg/u	0°-90°-180°
Cu	<input type="radio"/>	<input type="radio"/>	<input type="radio"/>
Zn	<input type="radio"/>	<input type="radio"/>	<input type="radio"/>
Cu		80x50 mm	€/u
	6-8 mm	18 kg/u	0°-90°-180°
Cu	<input type="radio"/>	<input type="radio"/>	<input type="radio"/>
Zn	<input type="radio"/>	<input type="radio"/>	<input type="radio"/>

# COTEK

HERRAJES PARA DUCHAS - ACCESSOIRES DE DOUCHE  
SCHOWER GLASS FITTINGS - ACCESSORI PER DOCCIA

CP. BRILLO CHR. POLI BR. CHR CP. LUC.	CP. MATE CHR. M M. CHR CP. OPAC	NEGRO NOIR BLACK NERO	INOX BR INOX POLI P.S.S. INOX LUC	INOX SAT INOX SAT S.S.S. INOX SAT
32	31	0N	22	28

## MALLORCA 8/10



**BISAGRA PARED-VIDRIO**  
CHARNIÈRE MUR-VERRE  
HINGE WALL-GLASS  
CERNIERA PARETE-VERTO

4100/0.. latón

4100/0.. inox 304

4100/Z32 zamak

4100/I0N inox 304

**BISAGRA DESPLAZADA PARED-VIDRIO**  
CHARNIÈRE MUR-VERRE DESPLACÉE  
HINGE WALL-GLASS OFFSET  
CERNIERA PARETE-VERTO ALA SPOSTATA

4103/0.. latón

4103/0.. inox 304

4103/Z32 zamak

4103/I0N inox 304

**BISAGRA VIDRIO-VIDRIO 180°**  
CHARNIÈRE VERRE-VERRE 180°  
HINGE GLASS-GLASS 180°  
CERNIERA VETRO-VETRO 180°

4101/0.. latón

4101/0.. inox 304

4101/Z32 zamak

4101/I0N inox 304

**HERRAJE FLUJO 90° VIDRIO-PARED**  
FIXATON VERRE-VERRE 90°  
BRACKET GLASS-GLASS 90°  
MORSETTO VETRO-VETRO 90°

4102/0..

4102/02. inox 304

4102/I0N

**BISAGRA 1 FLUJO+2 BISAGRAS 180°**  
CHARNIÈRE VERRE-VERRE 180°  
HINGE GLASS-GLASS 180°  
CERNIERA VETRO-VETRO 180°

4104/0.. latón

4104/I0N inox 304

### MUESCAS DIFERENTES LATÓN Y ZAMAK MISMA MUESCA INOX DISTINTA

	90x55 mm	€/u
	8-10 mm	22 kg/u
<input type="radio"/>	<input type="radio"/>	<input type="radio"/>
<input type="radio"/>	<input type="radio"/>	<input type="radio"/>
	90x55 mm	€/u
	8-10 mm	22 kg/u
<input type="radio"/>	<input type="radio"/>	<input type="radio"/>
<input type="radio"/>	<input type="radio"/>	<input type="radio"/>
	90x115 mm	€/u
	8-10 mm	22 kg/u
<input type="radio"/>	<input type="radio"/>	<input type="radio"/>
<input type="radio"/>	<input type="radio"/>	<input type="radio"/>
	90x55 mm	€/u
	8-10 mm	22 kg/u
<input type="radio"/>	<input type="radio"/>	<input type="radio"/>
<input type="radio"/>	<input type="radio"/>	<input type="radio"/>
	135x50 mm	€/u
	8-10 mm	22 kg/u
<input type="radio"/>	<input type="radio"/>	<input type="radio"/>
<input type="radio"/>	<input type="radio"/>	<input type="radio"/>

## BISAGRAS TEIDE - NUEVOS ACABADOS



**BISAGRA DESPLAZADA PARED-VIDRIO**  
CHARNIÈRE MUR-VERRE DESPLACÉE  
HINGE WALL-GLASS OFFSET  
CERNIERA PARETE-VERTO ALA SPOSTATA

4184/Z35 0°-90°-180°

Zn	80x50mm		€/u
	18 kg/u		



**BISAGRA VIDRIO-VIDRIO 180°**  
CHARNIÈRE VERRE-VERRE 180°  
HINGE GLASS-GLASS 180°  
CERNIERA VETRO-VETRO 180°

4181/Z35 0°-90°-180°

Zn	80x102mm		€/u
	18 kg/u		



**BISAGRA DESPLAZADA PARED-VIDRIO**  
CHARNIÈRE MUR-VERRE DESPLACÉE  
HINGE WALL-GLASS OFFSET  
CERNIERA PARETE-VERTO ALA SPOSTATA

4184/Z0N 0°-90°-180°

Zn	80x50mm		€/u
	18 kg/u		



**BISAGRA VIDRIO-VIDRIO 180°**  
CHARNIÈRE VERRE-VERRE 180°  
HINGE GLASS-GLASS 180°  
CERNIERA VETRO-VETRO 180°

4181/Z0N 0°-90°-180°

Zn	80x102mm		€/u
	18 kg/u		



**NUEVO**

## MALLORCA HIDRÁULICA



**BISAGRA PARED-VIDRIO**  
HIDRÁULICA CON LLAVE PARA  
REGULAR  
CHARNIÈRE MUR-VERRE HYDRAULIQUE  
AVEC CLÉ POUR RÉGULER  
WALL-GLASS HINGE HYDRAULIC  
WITH KEY FOR REGULATE IT  
CERNIERA MURO-VETRO IDRAULICO  
CON CHIAVE PER REGOLARLO

4100/H22

**BISAGRA VIDRIO-VIDRIO**  
HIDRÁULICA CON LLAVE PARA  
REGULAR  
CHARNIÈRE VERRE-VERRE HYDRAULIQUE  
AVEC CLÉ POUR RÉGULER  
GLASS-GLASS HINGE HYDRAULIC  
WITH KEY FOR REGULATE IT  
CERNIERA VETRO-VETRO IDRAULICO  
CON CHIAVE PER REGOLARLO

4101/H22

**BISAGRA PARED-VIDRIO**  
DESPLAZADA HIDRÁULICA  
CON LLAVE PARA REGULAR  
CHARNIÈRE MUR-VERRE DESPLACÉE  
HYDRAULIQUE AVEC CLÉ POUR RÉGULER  
WALL-GLASS HINGE HYDRAULIC OFFSET  
WITH KEY FOR REGULATE IT  
CERNIERA MURO-VETRO ALA SPOSTATA  
IDRAULICO CON CHIAVE PER REGOLARLO

4103/H22

### MISMA MUESCA QUE LATÓN Y ZAMAK

	Ciclos: 100.000	€/u
	8-12 mm	20 kg/u
<input type="radio"/>	<input type="radio"/>	<input type="radio"/>
<input type="radio"/>	<input type="radio"/>	<input type="radio"/>
	Ciclos: 100.000	€/u
	8-12 mm	20 kg/u
<input type="radio"/>	<input type="radio"/>	<input type="radio"/>
<input type="radio"/>	<input type="radio"/>	<input type="radio"/>
	Ciclos: 100.000	€/u
	8-12 mm	20 kg/u
<input type="radio"/>	<input type="radio"/>	<input type="radio"/>
<input type="radio"/>	<input type="radio"/>	<input type="radio"/>

**COTEK**

HERRAJES PARA DUCHAS - ACCESSOIRES DE DOUCHE  
SCHOWER GLASS FITTINGS - ACCESSORI PER DOCCIA

CR. BRILLO CH-R. POLI BR. CHR CR. ILLC.	TITAN TITANE TITANIUM TITANO	INOX BR INOX POLI P.S.S. INOX ILLC	INOX SAT INOX SAT S.S.S. INOX SAT
32	06	22	28

**IBIZA - INOX 316 8/12**



**BISAGRA PARED-VIDRIO**  
CHARNIÈRE MUR-VERRE  
HINGE WALL-GLASS  
CERNIERA PARETE-VERRO  
INOX 316  
4300/0..

inox s.s.		90x55 mm	€/u
		8-12 mm	25 kg/u 0°-90°-180°



**BISAGRA DESPLAZADA PARED-VIDRIO**  
CHARNIÈRE MUR-VERRE DESPLACÉE  
HINGE WALL-GLASS OFFSET  
CERNIERA PARETE-VERRO ALA SPOSTATA  
INOX 316L eje 304  
4303/0..

inox s.s.		90x55 mm	€/u
		8-12 mm	27 kg/u 0°-90°-180°



**BISAGRA VIDRIO-VIDRIO 180°**  
CHARNIÈRE VERRE-VERRE 180°  
HINGE GLASS-GLASS 180°  
CERNIERA VETRO-VETRO 180°  
INOX 316  
4301/0..

inox s.s.		90x115 mm	€/u
		8-12 mm	25 kg/u 0°-90°-180°



**BISAGRA VIDRIO-VIDRIO 90°**  
CHARNIÈRE VERRE-VERRE 90°  
HINGE GLASS-GLASS 90°  
CERNIERA VETRO-VETRO 90°  
INOX 316  
4302/0..

inox s.s.		90x55 mm	€/u
		8-12 mm	25 kg/u 0°-90°-180°

**HERRAJE FIJO INOX 316 90X55 MM**



**HERRAJE FIJO 90° PARED-VIDRIO**  
FIXATION MUR-VERRE 90°  
BRACKET WALL-GLASS 90°  
MORSETTO PARETE-VERRO 90°  
INOX 316  
4304/0..

inox s.s.		90x55 mm	€/u
		8-10 mm	2x Ø 16 mm

**HERRAJE FIJO 80X50 MM**



**HERRAJE FIJO 90° VIDRIO-PARED**  
FIXATION MUR-VERRE 90°  
BRACKET WALL-GLASS 90°  
MORSETTO PARETE-VERRO 90°  
\*4107/0..

Cu		80x50 mm	€/u
		6-10 mm	2x Ø 16 mm

**HERRAJE FIJO 90X55 MM**



**HERRAJE FIJO 90° PARED-VIDRIO**  
FIXATION MUR-VERRE 90°  
BRACKET WALL-GLASS 90°  
MORSETTO PARETE-VERRO 90°  
4106/032 latón   
4106/00N latón   
4106/022 inox 304   
4106/ION inox 304

		90x55 mm	€/u
		8-10 mm	2x Ø 16 mm

NEGRO  
NOIR  
BLACK  
NERO  
ON

**COTEK**

HERRAJES PARA DUCHAS - ACCESSOIRES DE DOUCHE  
SCHOWER GLASS FITTINGS - ACCESSORI PER DOCCIA

CR. BRILLO CH-R. POLI BR. CHR CR. ILLC.	PLÁSTICO PLASTIQUE PLASTIC PLASTICA	INOX BR INOX POLI P.S.S. INOX ILLC	INOX SAT INOX SAT S.S.S. INOX SAT
32	09	22	28

**LANZAROTE INOX DUPLEX 2205 - 8/12**



**BISAGRA PARED-VIDRIO**  
CHARNIÈRE MUR-VERRE  
HINGE WALL-GLASS  
CERNIERA PARETE-VERRO  
2200/0..

inox s.s.		90x55 mm	€/u
		8-12 mm	22 kg/u 0°-90°-180°



**BISAGRA DESPLAZADA PARED-VIDRIO**  
CHARNIÈRE MUR-VERRE DESPLACÉE  
HINGE WALL-GLASS OFFSET  
CERNIERA PARETE-VERRO ALA SPOSTATA  
2203/0..

inox s.s.		90x55 mm	€/u
		8-12 mm	22 kg/u 0°-90°-180°



**BISAGRA VIDRIO-VIDRIO 180°**  
CHARNIÈRE VERRE-VERRE 180°  
HINGE GLASS-GLASS 180°  
CERNIERA VETRO-VETRO 180°  
2201/0..

inox s.s.		90x115 mm	€/u
		8-12 mm	22 kg/u 0°-90°-180°

**TENERIFE - ESTANCA 100% INOX 316 - 8/10**



**BISAGRA VIDRIO-VIDRIO 180°**  
CHARNIÈRE VERRE-VERRE 180°  
HINGE GLASS-GLASS 180°  
CERNIERA VETRO-VETRO 180°  
4211/022

inox s.s.		115x90 mm	€/u
		8-10 mm	27 kg/u 0°-90°-180°

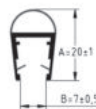

**TAPA JUNTA LATERAL BURBUJA**  
PROFIL ÉTANCHEITÉ LATERAL  
LATERAL SEAL  
GIUNTA LATERALE  
1833/109 8-10mm

pvc		2,2m		8-10mm	€/m
-----	--	------	--	--------	-----

La bisagra permite el paso del tapajunta y consigue la estanqueidad total

La charnière permet le passage de la couverture et réalise une étanchéité totale

The hinge allows the passage of the seal and achieves the total tightness

La cerniera consente il passaggio della giunta e risulta totalmente impermeabile



**LUGO**



**BISAGRA PARED-VIDRIO REGULABLE**  
CHARNIÈRE MUR-VERRE ADJUSTABLE  
HINGE WALL-GLASS REGULABLE  
CERNIERA PARETE-VERRO REGOLABILE  
5310/R32 regulable

Cu		177x55 mm	€/u
		8-10 mm	22 kg/u 0°-90°-180°



**BISAGRA REGULABLE VID-VID. 180°**  
CHARNIÈRE RÉGLABLE VER-VER. 180°  
ADJUSTABLE HINGE GLASS-GLASS 180°  
CERNIERA REGOLABILE VET-VET. 180°  
5311/R32 regulable

Cu		228x55 mm	€/u
		8-10 mm	22 kg/u 0°-90°-180°

**NUEVO**





# COTEK

HERRAJES PARA DUCHAS - ACCESSOIRES DE DOUCHE  
SCHOWER GLASS FITTINGS - ACCESSORI PER DOCCIA

## MALLORCA PLUS 8/10

CR. BRILLO	CR. MATE	NEGRO	INOX BR
CR. POLI	CHR. M	NOIR	INOX POLI
BR. CHR	M. CHR	BLACK	P.S.S.
CR. LUC.	CR. OPAC	NERO	INOX LUC

32	31	0N	22
Cu		90x55 mm	€/u
	8-10 mm	22 kg/u	0°-90°-180°

○	○
---	---

	90x115 mm	€/u	
	8-10 mm	22 kg/u	0°-90°-180°

○	○
---	---



**BISAGRA PARED-VIDRIO CON TAPAS EMBELLECEDORAS**  
CHARNIÈRE MUR-VERRE  
HINGE WALL-GLASS  
CERNIERA PARETE-VETRO  
**4103/T..** latón  
AVEC COUVERTURE WITH COVERS CON COPERTINE



**BISAGRA VIDRIO-VIDRIO 180° CON TAPAS EMBELLECEDORAS**  
CHARNIÈRE VERRE-VERRE 180°  
HINGE GLASS-GLASS 180°  
CERNIERA VETRO-VETRO 180°  
**4101/T..** latón  
AVEC COUVERTURE WITH COVERS CON COPERTINE

## MALLORCA REGULABLE 8/10

Cu		90x55 mm	€/u
	8-10 mm	22 kg/u	0°-90°-180°

○	
---	--

Cu		90x115 mm	€/u
	8-10 mm	22 kg/u	0°-90°-180°

○	
---	--



**BISAGRA PARED-VIDRIO ÁNGULO REGULABLE**  
CHARNIÈRE MUR-VERRE  
HINGE WALL-GLASS  
CERNIERA PARETE-VETRO  
**4100/R32** latón  
ANGLE AXE RÉGLABLE ADJUSTABLE AXIS ANGLE ANGOLO ASSE REGULABILE



**BISAGRA VIDRIO-VIDRIO 180° ÁNGULO REGULABLE**  
CHARNIÈRE VERRE-VERRE 180°  
HINGE GLASS-GLASS 180°  
CERNIERA VETRO-VETRO 180°  
**4101/R32** latón  
ANGLE AXE RÉGLABLE ADJUSTABLE AXIS ANGLE ANGOLO ASSE REGULABILE

## MENORCA - REGULABLE 8/10

Cu		112x55 mm	€/u
	8-10 mm	22 kg/u	0°-90°-180°

○	
---	--

Cu		228x55 mm	€/u
	8-10 mm	22 kg/u	0°-90°-180°

○	
---	--



**BISAGRA PARED-VIDRIO REGULABLE**  
CHARNIÈRE MUR-VERRE  
ADJUSTABLE HINGE WALL-GLASS  
CERNIERA PARETE-VETRO REGOLABILE  
**4187/R32** regulable



**BISAGRA REGULABLE VID.-VID. 180°**  
CHARNIÈRE RÉGLABLE VER.-VER. 180°  
ADJUSTABLE HINGE GLASS-GLASS 180°  
CERNIERA REGOLABILE VET.VET. 180°  
**4186/R32** regulable

## HERRAJE FIJO 45X45 MM

	45x45 mm	€/u
	8-12 mm	∅ 16 mm

inox s.s.	○
Zn	○
Zn	○

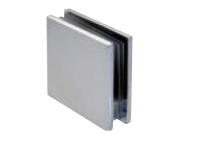

**HERRAJE FIJO 90° PARED-VIDRIO**  
FIXATION MUR-VERRE 90°  
BRACKET WALL-GLASS 90°  
MORSETTO PARETE-VETRO 90°  
**4108/022** inox  
**4108/Z32** zamak  
**4108/ZON** zamak

# COTEK BLACK

HERRAJES PARA DUCHAS - ACCESSOIRES DE DOUCHE  
SCHOWER GLASS FITTINGS - ACCESSORI PER DOCCIA

NEGRO
NOR
BLACK
NERO
0N

## MALLORCA PLUS NEGRO

Cu		90x55 mm	€/u
	8-10 mm	22 kg/u	0°-90°-180°

○	
---	--

Cu		90x55 mm	€/u
	8-10 mm	22 kg/u	0°-90°-180°

○	
---	--



**BISAGRA PARED-VIDRIO CON TAPAS EMBELLECEDORAS**  
CHARNIÈRE MUR-VERRE  
HINGE WALL-GLASS  
CERNIERA PARETE-VETRO  
**4103/TON** latón  
AVEC COUVERTURE WITH COVERS CON COPERTINE



**BISAGRA VIDRIO-VIDRIO 180° CON TAPAS EMBELLECEDORAS**  
CHARNIÈRE VERRE-VERRE 180°  
HINGE GLASS-GLASS 180°  
CERNIERA VETRO-VETRO 180°  
**4101/TON** latón

## MALLORCA NEGRO

Cu		90x55 mm	€/u
	8-10 mm	22 kg/u	0°-90°-180°

○	
---	--

inox s.s.		90x55 mm	€/u
	8-10 mm	22 kg/u	0°-90°-180°

○	
---	--



**BISAGRA PARED-VIDRIO**  
CHARNIÈRE MUR-VERRE  
HINGE WALL-GLASS  
CERNIERA PARETE-VETRO  
**4100/00N** latón  
**4100/10N** inox



**BISAGRA PARED-VIDRIO**  
CHARNIÈRE MUR-VERRE  
HINGE WALL-GLASS  
CERNIERA PARETE-VETRO  
**4103/00N** latón  
**4103/10N** inox



**BISAGRA VIDRIO-VIDRIO 180°**  
CHARNIÈRE VERRE-VERRE 180°  
HINGE GLASS-GLASS 180°  
CERNIERA VETRO-VETRO 180°  
**4101/00N** latón  
**4101/10N** inox



**BISAGRA VIDRIO-VIDRIO**  
CHARNIÈRE VERRE-VERRE  
HINGE GLASS-GLASS  
CERNIERA VETRO-VETRO  
**4102/00N** latón  
**4102/10N** inox

## TEIDE NEGRO

zn		80x50 mm	€/u
	6-8 mm	18 kg/u	0°-90°-180°

○	
---	--



**BISAGRA DESPLAZADA PARED-VIDRIO**  
CHARNIÈRE VERRE-MUR  
DESPLACÉE  
HINGE WALL-GLASS OFFSET  
CERNIERA PARETE-VETRO  
ALA SPOSTATA  
**4184/ZON**



**BISAGRA VIDRIO-VIDRIO 180°**  
CHARNIÈRE VERRE-VERRE 180°  
HINGE GLASS-GLASS 180°  
CERNIERA VETRO-VETRO 180°  
**4181/ZON**



## COTEK BLACK

HERRAJES PARA DUCHAS - ACCESSOIRES DE DOUCHE  
SCHOWER GLASS FITTINGS - ACCESSORI PER DOCCIA

NEGRO  
NOIR  
BLACK  
NERO  
ON

### POMOS Y TIRADORES



**TIRADOR DOBLE**  
BOUTON DOUBLE  
DOUBLE KNOB  
POMOLO DOPPIO  
**4281/ZON**

Zn	∅45x28	∅ 12 mm	€/u
		6-10 mm	

○



**MANILLA DOBLE**  
POIGNÉE DOUBLE  
DOUBLE DOOR PULL  
MANIGLIA DOPPIA  
**4139/ZON**

Zn	6-10 mm	226x34	€/u
		2 x ∅ 6 mm	CC=191 mm

○



**UÑERO**  
POIGNÉE  
KNOB  
POMO  
**4337/00N**

inox s.s.	8-12 mm	∅ 46 mm	€/u
-----------	---------	---------	-----

○



**POMO + TOALLERO**  
POIGNÉE + SERVIETTE  
KNOB WITH TOWEL BAR  
POMOLO CON PORTA  
ASCIUGAMANO  
**1891/00N**

inox	8-10 mm	25x25	€/u
		2 x ∅8 - ∅10 mm	CC=450 mm

○

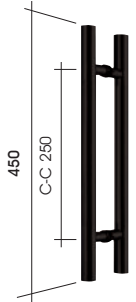

**MANILLA DOBLE 45 CM**  
POIGNÉE DOUBLE 45 CM  
DOUBLE DOOR HANDLE 45 CM  
MANIGLIA DOPPIA 45 CM  
**1590/0..**

inox s.s.	8-12 mm	∅ 25	€/u
		2x∅12 mm	CC=250 mm

○



**TIRADOR DOBLE**  
BOUTON DOUBLE  
DOUBLE KNOB  
POMOLO DOPPIO  
**4124/ZON**

zn	6-10 mm	∅ 29 mm	€/u
		∅ 8-10 mm	

○



**UÑERO DOBLE ADHESIVO**  
POIGNÉE DOUBLE ADHESIVE  
DOUBLE ADHESIVE PULL  
POMO DOPPIO ADHESIVO  
**4207/00N**

ix	∅ 60 mm		€/u
----	---------	--	-----

○

### HERRAJE FIJO 90X55 MM



**HERRAJE FIJO 90° PARED-VIDRIO**  
FIXATION MUR-VERRE 90°  
BRACKET WALL-GLASS 90°  
MORSETTO PARETE-  
VETRO 90°

**4106/00N** latón  
**4106/ION** Inox

inox s.s.		90x55 mm	€/u
	8-10 mm	2x ∅ 16 mm	

○



**NUEVO**

## COTEK BLACK

HERRAJES PARA DUCHAS - ACCESSOIRES DE DOUCHE  
SCHOWER GLASS FITTINGS - ACCESSORI PER DOCCIA

PLÁSTICO  
PLASTIQUE  
PLASTIC  
PLASTICA  
09  
NEGRO  
NOIR  
BLACK  
NERO  
ON

### BARRAS DE REFUERZO



**BARRA REFUERZO EXTENSIBLE**  
BARRÉ RENFORT  
FIXING BAR  
BARRA RINFORZO  
**4166/0..**

Cu	inox s.s.	6-10 mm	70-120 cm	€/u
----	-----------	---------	-----------	-----

○

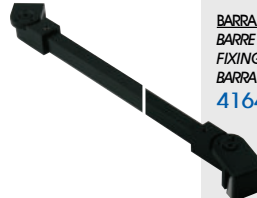

**BARRA REFUERZO 90°**  
BARRÉ RENFORT 90°  
FIXING BAR 90°  
BARRA RINFORZO 90°  
**4164/00N**

Zn	inox s.s.	6-10 mm	€/u
		1000 mm	

○



**BARRA REFUERZO PARED-VIDRIO 45°**  
BARRÉ RENFORT MUR-VERRE 45°  
FIXING BAR WALL-GLASS 45°  
BARRA RINFORZO VETRO-MURO 45°  
**4167/00N**

Zn	inox s.s.	6-10 mm	€/u
		393 mm	

○

### ACCESORIOS NEGRO



**HERRAJE FIJO 90° PARED-VIDRIO**  
FIXATION MUR-VERRE 90°  
BRACKET WALL-GLASS 90°  
MORSETTO PARETE-VETRO 90°  
**4108/ZON** zamak

Zn		45x45 mm	€/u
	8-12 mm	∅ 16 mm	

○



**"U" ALUMINIO**  
U ALUMINIUM  
U ALLUMINIUM  
U ALLUMINIO  
**1659/10N** 15x15x15x1,5 mm

		max.10 mm	
--	--	-----------	--

○



**PERFIL BURLETE DE ALUMINIO**  
PROFILE LEVRE-UO  
LIP-UP PROFILE  
PROFILO VERTIACQUE  
**1831/20N**

Al		2 m	21x6,5	€/u
----	--	-----	--------	-----

○



**"U" ALUMINIO REGULABLE**  
"U" ALUMINIUM, REGLABLE  
"U" ALUMINIUM, ADJUSTABLE  
"U" DI ALUMINIO, REGOLABILE

Al		2,1 m	36x22 mm	€/u
		∅ 1671-1672		

○

Perfil de aluminio a pared  
**1670/20N**

Junta para vidrio 8 mm  
**1671/209**

Pla		2,1 m	8 mm	∅ 1670	€/u
-----	--	-------	------	--------	-----

○

TAPA SUPERIOR Y TACOS PARED INCLUIDOS EN KIT

Junta para vidrio 6 mm  
**1672/209**

Pla		2,1 m	6 mm	∅ 1670	€/u
-----	--	-------	------	--------	-----

○



**NUEVO**

## COTEK - BISAGRA NIZA PLUS



### BISAGRA NIZA PLUS

- Alta calidad
- Acabado negro anodizado
- Basculante con eje nylon

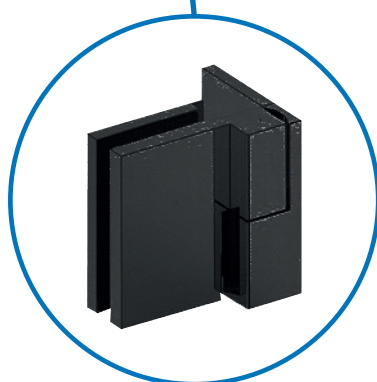

### BISAGRA NIZA BASCULANTE

Material del eje basculante:  
- 10 veces más resistente de los materiales en el mercado

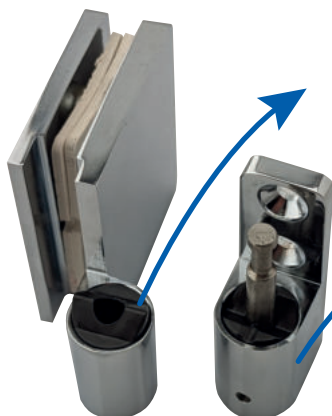

Plástico extra resistente con garantía de 50.000 ciclos de apertura

Latón macizo. Acabado cromado de grado 5 (480 h.) en la prueba con niebla salina



Bisagra basculante. Se cierra automáticamente por su propio peso. Retención a 0, 90 y 180°



**COTEK**

HERRAJES PARA DUCHAS - ACCESSOIRES DE DOUCHE  
SHOWER GLASS FITTINGS - ACCESSORI PER DOCCIA

**\*BISAGRA NIZA PLUS  
BASCULANTE (EJE NYLON)**



**BISAGRA NIZA PLUS 90°**  
CHARNIÈRE NIZA PLUS 90°  
NIZA PLUS 90° HINGE  
CERNIERA NIZA PLUS 90°  
**\*5240/00N DER**

lx		Ø 14mm	€/u
		8-10 mm	

\*o



**BISAGRA NIZA PLUS 90°**  
CHARNIÈRE NIZA PLUS 90°  
NIZA PLUS 90° HINGE  
CERNIERA NIZA PLUS 90°  
**\*5241/00N IZQ**

lx		Ø 14mm	€/u
		8-10 mm	

\*o



**BISAGRA NIZA PLUS 180°**  
CHARNIÈRE NIZA PLUS 180°  
NIZA PLUS 180° HINGE  
CERNIERA NIZA PLUS 180°  
**\*5242/00N DER**

lx		Ø 14mm	€/u
		8-10 mm	

\*o



**BISAGRA NIZA PLUS 180°**  
CHARNIÈRE NIZA PLUS 180°  
NIZA PLUS 180° HINGE  
CERNIERA NIZA PLUS 180°  
**\*5243/00N IZQ**

lx		Ø 14mm	€/u
		8-10 mm	

\*o

**NIZA - BASCULANTE  
CON EJE DE  
PLÁSTICO EXTRA RESISTENTE**

CR. BRILLO  
CHR. POLI  
BR. CHR  
CR. LUC.

32



**BISAGRA BASCULANTE PARED-VIDRIO**  
CHARNIÈRE + LEVANTMENT MUR-VERRE  
RISING HINGE WALL-GLASS  
CERNIERA PARETE-VETRO CON ALZATA  
**4140/032** der.  
droite/right/destra  
**4141/032** izq.  
gauche/left/sinistra

Cu	20 kg/u	2x Ø 16 mm	€/u
		8-10 mm	75x58 mm
			0°-90°

o

o



**BISAGRA BASCULANTE VID.-VID. 180°**  
CHARNIÈRE + LEVANTMENT V.-V. 180°  
RISING HINGE GLASS-GLASS 180°  
CERNIERA VET-VET. 180° CON ALZATA  
**4142/032** der.  
droite/right/destra  
**4143/032** izq.  
gauche/left/sinistra

Cu	20 kg/u	2x Ø 16 mm	€/u
		8-10 mm	120x58 mm
			0°-90°

o

o



**HERRAJE FIJO 90° PARED-VIDRIO**  
FIXATION MUR-VERRE 90°  
BRACKET WALL-GLASS 90°  
MORSETTO PARETE-VETRO 90°  
**\*4144/032**

Cu		48x58 mm	€/u
		8-10 mm	2x Ø 16 mm

o

**COTEK**

HERRAJES PARA DUCHAS - ACCESSOIRES DE DOUCHE  
SHOWER GLASS FITTINGS - ACCESSORI PER DOCCIA

CR. BRILLO CHR. POLI BR. CHR CR. LUC.	CR. MATE CHR. M M. CHR CR. OPAC	INOX BR INOX POLI P.S.S. INOX LUC	INOX SAT INOX SAT S.S.S. INOX SAT
32	31	22	28

**\*LISBOA INOX 304 8/10 (PLEGABLES)**

IDEAL PARA PUERTAS PLEGABLES. SIN RETENCIÓN  
IDÉAL POUR LES PORTES PLIANTES. SANS RÉTENTION  
IDEAL FOR FOLDING DOORS. WITHOUT RETENTION  
IDEALE PER PORTE PIEGHEVOLI. SENZA RITENZIONE



**BISAGRA PARED-VIDRIO**  
CHARNIÈRE MUR-VERRE  
HINGE WALL-GLASS  
CERNIERA PARETE-VETRO  
**\*4402/022**

inox s.s.	20 kg/u		€/u
		6-8 mm	60x45mm
			0°-90°

\*o



**BISAGRA VIDRIO-VIDRIO**  
CHARNIÈRE VRR-VERRE  
HINGE GLASS-GLASS  
CERNIERA VETRO-VETRO  
**\*4403/033**

inox s.s.	20 kg/u		€/u
		6-8 mm	60x45mm
			0°-90°

\*o

**VENECIA 6/8**



**BISAGRA PARED-VIDRIO**  
CHARNIÈRE MUR-VERRE  
HINGE WALL-GLASS  
CERNIERA PARETE-VETRO  
**4195/032**

Cu	20 kg/u	2x Ø 14 mm	€/u
		6-8 mm	60x45mm
			0°-90°

o



**BISAGRA VIDRIO-VIDRIO 180°**  
CHARNIÈRE VERRE-VERRE 180°  
HINGE GLASS-GLASS 180°  
CERNIERA VETRO-VETRO 180°  
**4196/032**

Cu	20 kg/u	2x Ø 14 mm	€/u
		6-8 mm	120x45mm
			0°-90°

o



**HERRAJE FIJO 90° PARED-VIDRIO**  
FIXATION MUR-VERRE 90°  
BRACKET WALL-GLASS 90°  
MORSETTO PARETE-VETRO 90°  
**4197/032**

Cu		45x50 mm	€/u
		6-8 mm	2x Ø 14 mm

o



**HERRAJE FIJO 90° VIDRIO-VIDRIO**  
FIXATION VERRE-VERRE 90°  
BRACKET GLASS-GLASS 90°  
MORSETTO VETRO-VETRO 90°  
**4198/032**

Cu		45x50 mm	€/u
		6-8 mm	2x Ø 14 mm

o

**MÓNACO 6/8**



**BISAGRA PARED-VIDRIO**  
CHARNIÈRE MUR-VERRE  
HINGE WALL-GLASS  
CERNIERA PARETE-VETRO  
**1819/032**

Cu	18 kg/u	2x Ø 16 mm	€/u
		6-8 mm	65x45mm
			0°-90°

o



**BISAGRA VIDRIO-VIDRIO 180°**  
CHARNIÈRE VERRE-VERRE 180°  
HINGE GLASS-GLASS 180°  
CERNIERA VETRO-VETRO 180°  
**1817/032**

Cu	18 kg/u	2x Ø 12 mm	€/u
		6-8 mm	102x45mm
			0°-90°

o



**MORSETTO VIDRIO-PARED**  
FIXATION VERRE-MUR  
BRACKET GLASS-WALL  
MORSETTO VETRO-PARETE  
**4105/032**

Cu		60x50 mm	€/u
		8-12 mm	Ø 16 mm

o

**COTEK**

HERRAJES PARA DUCHAS - ACCESSOIRES DE DOUCHE  
SCHOWER GLASS FITTINGS - ACCESSORI PER DOCCIA

**HERRAJES FIJOS**



**HERRAJE FIJO 90° VIDRIO-PARED**  
FIXATION MUR-VERRE 90°  
BRACKET WALL-GLASS 90°  
MORSETTO PARETE-VETRO 90°  
**4107/032** latón  
**4107/006** aluminio



**HERRAJE FIJO 90° PARED-VIDRIO**  
FIXATION MUR-VERRE 90°  
BRACKET WALL-GLASS 90°  
MORSETTO PARETE-VETRO 90°  
**4106/032** latón  
**4106/022** inox 304  
**4106/00N** latón  
**4106/10N** inox 304



**HERRAJE FIJO 90° PARED-VIDRIO**  
FIXATION MUR-VERRE 90°  
BRACKET WALL-GLASS 90°  
MORSETTO PARETE-VETRO 90°  
INOX 316 satin  
**4304/0..**



**HERRAJE FIJO 90° PARED-VIDRIO**  
FIXATION MUR-VERRE 90°  
BRACKET WALL-GLASS 90°  
MORSETTO PARETE-VETRO 90°  
**4199/032**



**HERRAJE FIJO 90° PARED-VIDRIO**  
FIXATION MUR-VERRE 90°  
BRACKET WALL-GLASS 90°  
MORSETTO PARETE-VETRO 90°  
**\*4144/032**



**HERRAJE FIJO 90° PARED-VIDRIO**  
FIXATION MUR-VERRE 90°  
BRACKET WALL-GLASS 90°  
MORSETTO PARETE-VETRO 90°  
**\*4407/032** zamak



**HERRAJE FIJO 90° PARED-VIDRIO**  
FIXATION MUR-VERRE 90°  
BRACKET WALL-GLASS 90°  
MORSETTO PARETE-VETRO 90°  
**4197/032**



**HERRAJE FIJO 90° VIDRIO-VIDRIO**  
FIXATION VERRE-VERRE 90°  
BRACKET GLASS-GLASS 90°  
MORSETTO VETRO-VETRO 90°  
**4198/032**



**HERRAJE FIJO 90° PARED-VIDRIO**  
FIXATION MUR-VERRE 90°  
BRACKET WALL-GLASS 90°  
MORSETTO PARETE-VETRO 90°  
**4108/022** inox

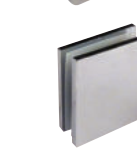

**4108/Z32** zamak  
**4108/Z0N** zamak negro



**MORSETO VIDRIO-PARED**  
FIXATION VERRE-MUR  
BRACKET GLASS-WALL  
MORSETTO VETRO-PARETE  
**4105/032**

CR. BRILLO	TITAN	INOX BR	INOX SAT
CR. POLI	TITANE	INOX POLI	INOX SAT
BR. CHR	TITANUM	P.S.S.	S.S.S.
CR. LUC.	TITANIO	INOX LUC	INOX SAT
<b>32</b>	<b>06</b>	<b>22</b>	<b>28</b>

Cu	80x50 mm	€/u
6-10 mm	2x Ø 16 mm	

	90x55 mm	€/u
8-10 mm	2x Ø 16 mm	

inox s.s.	90x50 mm	€/u
8-10 mm	2x Ø 16 mm	

Cu	51x51 mm	€/u
8-10 mm	Ø 16 mm	

Cu	48x58 mm	€/u
8-10 mm	2x Ø 16 mm	

Zn	90x55 mm	€/u
8-10 mm	2x Ø 16 mm	

Cu	45x50 mm	€/u
6-8 mm	2x Ø 14 mm	

Cu	45x50 mm	€/u
6-8 mm	2x Ø 14 mm	

CR. BRILLO	NEGRO	INOX BR
CR. POLI	NOR	INOX POLI
BR. CHR	BLACK	P.S.S.
CR. LUC.	NERO	INOX LUC
<b>32</b>	<b>0N</b>	<b>22</b>

	45x45 mm	€/u
8-12 mm	Ø 16 mm	

inox s.s.		
-----------	--	--

Zn		
----	--	--

Zn		
----	--	--

Cu	60x50 mm	€/u
8-12 mm	Ø 16 mm	

**COTEK**

HERRAJES PARA DUCHAS - ACCESSOIRES DE DOUCHE  
SCHOWER GLASS FITTINGS - ACCESSORI PER DOCCIA



**HERRAJE FIJO 90° PARED-VIDRIO**  
FIXATION MUR-VERRE 90°  
BRACKET WALL-GLASS 90°  
MORSETTO PARETE-VETRO 90°  
**4095/032** latón



**HERRAJE FIJO 90° VIDRIO-VIDRIO**  
FIXATION VERRE-VERRE 90°  
BRACKET GLASS-GLASS 90°  
MORSETTO VETRO-VETRO 90°  
**4096/032** latón  
**\*4096/022** inox



**HERRAJE FIJO 180° VIDRIO-VIDRIO**  
FIXATION VERRE-VERRE 180°  
BRACKET GLASS-GLASS 180°  
MORSETTO VETRO-VETRO 180°  
**\*4097/032** latón



**HERRAJE FIJO 90° VIDRIO-VIDRIO**  
FIXATION VERRE-VERRE 90°  
BRACKET GLASS-GLASS 90°  
MORSETTO VETRO-VETRO 90°  
**4099/022** inox

**"U" INOX**



"U" INOX PULIDO  
U INOX POLI  
U POL. STAINLESS STEEL  
U INOX LUCIDO

15x15x15x1 mm  
**4375/122**  
15x12x15x1mm  
**4376/122**  
25x15x25x1mm  
**4377/122**

**PERFIL FIJO LATERAL MAMPARA**



"U" ALUMINIO, REGULABLE  
"U" ALUMINIUM, RÉGLABLE  
"U" ALUMINIUM, ADJUSTABLE  
"U" DI ALUMINIO, REGOLABILE

Perfil de aluminio a pared  
**1670/202**

Junta para vidrio 8 mm  
**1671/209**

Junta para vidrio 6 mm  
**1672/209**

TAPA SUPERIOR Y TACOS  
PARED INCLUIDOS EN KIT



"U" ALUMINIO PARED  
"U" ALUMINIUM MUR  
"U" DI ALUMINIO WALL  
"U" DI ALUMINIO PARETE  
Vidrio de 8 mm  
**5961/202**

CR. BRILLO	TITAN	INOX BR	INOX SAT
CR. POLI	TITANE	INOX POLI	INOX SAT
BR. CHR	TITANUM	P.S.S.	S.S.S.
CR. LUC.	TITANIO	INOX LUC	INOX SAT
<b>32</b>	<b>06</b>	<b>22</b>	<b>28</b>

Cu	inox s.s.	45x45 mm	€/u
6-12 mm		Ø 14 mm	

Cu	inox s.s.	45x45 mm	€/u
6-12 mm		2x Ø 14 mm	

Cu	inox s.s.	90x45 mm	€/u
6-12 mm		2x Ø 14 mm	

inox s.s.		90x45 mm	€/u
8-12 mm		3x Ø 14 mm	

inox s.s.	3 m	€/m
-----------	-----	-----

	max. 12 mm
--	------------

	max. 8 mm
--	-----------

	max. 12 mm
--	------------

an.brillo	plastico	NEGRO
an.poli	plastic	NOR
an.chr	plastic	BLACK
an.luc.	plastica	NERO
<b>02</b>	<b>09</b>	<b>0N</b>

Al	2,1 m	36x22 mm	€/u
	∞	1671-1672	

Pla	2,1 m	8 mm	∞ 1670	€/u
-----	-------	------	--------	-----

Pla	2,1 m	6 mm	∞ 1670	€/u
-----	-------	------	--------	-----

Al	1,95 m	8 mm	€/u
----	--------	------	-----



**COTEK**

HERRAJES PARA DUCHAS - ACCESSOIRES DE DOUCHE  
SCHOWER GLASS FITTINGS - ACCESSORI PER DOCCIA

CR. BRILLO CHR. POLI BR. CHR. CR. LUC.	ORO. MATE MAT. DORE MAT. GOLD DOR. OPP.	NEGRO NOR BLACK NERO	INOX BR. INOX POLI P.S.S. INOX LUC.	INOX SAT INOX SAT S.S.S. INOX SAT
32	35	0N	22	28

**BARRAS REFUERZO**

**BARRA REFUERZO EXTENSIBLE**  
BARRERENFORT  
FIXING BAR  
BARRARINFORZO

4166/0..

Cu	inox s.s.	6-10 mm	70-120 cm	€/u
----	--------------	---------	-----------	-----



**BARRA REFUERZO TELESCÓPICA 90°**  
BARRERENFORT TELESCOPIQUE 90°  
TELESCOPIIC FIXING BAR 90°  
BARRARINFORZO TELESCOPIICA 90°

4160/0..

Cu	inox s.s.	6-10 mm	770-1030 m	€/u
----	--------------	---------	------------	-----

770-1030

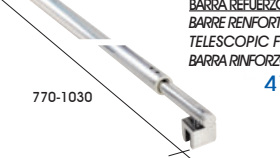

**BARRA REFUERZO PARED-VIDRIO 45°**  
BARRERENFORT MUR-VERRE 45°  
FIXING BAR WALL-GLASS 45°  
BARRARINFORZO PARETE-VERRO 45°

4167/0.. 393 mm  
4169/032 1000 mm

inox s.s.	6-10 mm		€/u
--------------	---------	--	-----

419 (ref.4167)  
1000 (ref.4169)

45°



**BARRA REFUERZO PARED-VIDRIO 45°**  
BARRERENFORT MUR-VERRE 45°  
FIXING BAR WALL-GLASS 45°  
BARRARINFORZO PARETE-VERRO 45°

1890/022

inox s.s.	6-10 mm	294 mm	€/u
--------------	---------	--------	-----



**BARRA REFUERZO REGULABLE**  
BARRERENFORT  
FIXING BAR  
BARRARINFORZO

4164/0..

Zn	inox s.s.	6-10 mm	1000 m	€/u
----	--------------	---------	--------	-----

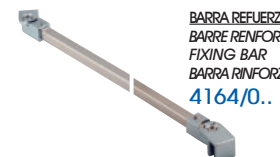

**BARRA REFUERZO VIDRIO-VIDRIO 45°**  
BARRERENFORT VERRE-VERRE 45°  
FIXING BAR GLASS-GLASS 45°  
BARRARINFORZO VETRO-VETRO 45°

4165/032

Al	6-10 mm	419 mm	€/u
----	---------	--------	-----



**BARRAS DE REFUERZO -  
NUEVOS ACABADOS**

**BARRA DE REFUERZO  
PARED-VIDRIO 45°**  
BARRERENFORT MUR-VERRE  
45°  
FIXING BAR WALL-GLASS 45°  
BARRARINFORZO  
PARETE-VERRO 45°

4167/035

lx	6-10 mm	393 mm	€/u
----	---------	--------	-----



**BARRA DE REFUERZO  
PARED-VIDRIO 45°**  
BARRERENFORT MUR-VERRE  
45°  
FIXING BAR WALL-GLASS 45°  
BARRARINFORZO  
PARETE-VERRO 45°

4167/00N

lx	6-10 mm	393 mm	€/u
----	---------	--------	-----

**BARRA DE REFUERZO  
REGULABLE**  
BARRERENFORT RÉGLABLE  
ADJUSTABLE REINFORCEMENT  
BAR  
BARRARINFORZO  
REGOLABILE

4164/035

lx	6-10 mm	1.000 mm	€/u
----	---------	----------	-----



**! NUEVO**

**COTEK**

HERRAJES PARA DUCHAS - ACCESSOIRES DE DOUCHE  
SCHOWER GLASS FITTINGS - ACCESSORI PER DOCCIA

CR. BRILLO CHR. POLI BR. CHR. CR. LUC.	CR. MATE CHR. M M. CHR. CR. OPAC	INOX BR. INOX POLI P.S.S. INOX LUC.
32	31	22

**PORTAESTANTE VIDRIO-VIDRIO**

**PORTAESTANTE VIDRIO-VIDRIO**  
Vidrio 8-10 mm (base)  
6-8 mm (estante)  
TAQUET SUPPORT BRACKET  
Verre avec trous 8-10 mm  
Verre tablette 6-8 mm  
FITTING FOR GLASS SHELF  
Glass drilled 8-10 mm  
Glass shelf 6-8 mm  
ACCESSORIO PER MENSOLA VETRO  
Vetro con foro 8-10 mm  
Vetro mensola 6-8 mm

4959/032

Cu	8-10 mm	6-8 mm	10 mm	€/u
----	---------	--------	-------	-----



**DISTANCIADOR SUELO**

**PINZA DISTANCIADOR SUELO-VIDRIO**  
SUPPORT REVÊTEMENT-VERRE  
SUPPORT FLOOR-GLASS  
SUPPORTO PER SEPARAZIONI PAVIMENTO

1425/022

inox s.s.	6-10 mm	€/u
123-130 m		

123/130



**CIERRE PARA LAVABOS**

**CIERRE WC PARED-VIDRIO SIN MUESCA  
+ CONTRACERRADURA**  
SERRURE WC MUR-VERRE  
SANS ENCOCHE + GAÛCHE  
LOCK FOR WC WALL-GLASS  
WITHOUT CUT-OUT + STRIKE  
SERRATURA WC PARETE-VERRO  
SENZA TACCA + CONTROSERRATURA

4138/032

Zn	8-10 mm	€/u
----	---------	-----



**CIERRE WC VIDRIO-VIDRIO SIN MUESCA  
+ CONTRACERRADURA**  
SERRURE WC VERRE-VERRE  
SANS ENCOCHE + GAÛCHE  
LOCK FOR WC GLASS-GLASS  
WITHOUT CUT-OUT + STRIKE  
SERRATURA WC VETRO-VETRO  
SENZA TACCA + CONTROSERRATURA

4137/032

Zn	8-10 mm	€/u
----	---------	-----



**CIERRE WC VIDRIO-VIDRIO  
+CONTRACERRADURA**  
SERRURE WC VERRE-VERRE+ GAÛCHE  
LOCK FOR WC GLASS-GLASS+ STRIKE  
SERRATURA WC VETRO-VETRO  
+CONTROSERRATURA

4133/022

inox s.s.	8-10 mm	€/u
--------------	---------	-----



**CIERRE WC PICO DE LORO  
PARED - VIDRIO**  
SERRURE A CROCHET WC MUR-VERRE  
HOOK LOCK WC WALL-GLASS  
SERRATURA A GANCIO WC  
PARETE-VERRO

4130/32Z

Zn	8-10 mm	€/u
----	---------	-----



**CIERRE WC PICO DE LORO  
VIDRIO - VIDRIO**  
SERRURE A CROCHET WC VERRE-VERRE  
HOOK LOCK WC GLASS-GLASS  
SERRATURA A GANCIO WC VETRO-VETRO  
+CONTROSERRATURA

4132/32Z

Zn	8-10 mm	€/u
----	---------	-----



**! NUEVO**

# BARRA DE REFUERZO PERIMETRAL TUBO CUADRADO 19X19

NOX BR  
NOX POU  
P.S.S.  
NOX W/C  
22



**ANCLAJE PARED**  
CONNEXION MUR-VERRE  
CONNEXION WALL-GLASS  
AGGANCIO PARETE-VETRO  
**6090/022**

lx €/u



**CONEXIÓN ANGULAR**  
CONNEXION ANGLE TUBE  
CORNER CONNEXION  
CONNESSIONE TUBI  
**6092/022**

lx €/u



**SOPORTE FINAL VIDRIO-TUBO**  
AGUJERO TAPADO  
SUPPORT FIXATION  
TUBE-VERRE BOUCHÉ  
CONNEXION TUBE-GLASS  
CLOSED  
AGANCIO TUBO-VETRO  
TAPPATO  
**6087/022**

lx 8-10 mm €/u



**SOPORTE VIDRIO-TUBO**  
AGUJERO PASANTE  
SUPPORT TUBE-VERRE  
TRAVERSANT  
THROUGH-HOLE  
CONNEXION TUBE-GLASS  
AGANCIO TUBO-VETRO A  
FORO PASSANTE  
**6091/022**

lx 8-10 mm €/u



**CONEXIÓN ANGULAR 90°**  
CONNEXION ANGLE TUBE 90°  
CORNER CONNEXION 90°  
CONNESSIONE TUBI 90°  
**6089/022**

lx €/u



**SOPORTE FINAL PARED-TUBO ARTICULADO**  
SUPPORT FIXATION TUBE-WALL  
CONNEXION TUBE-WALL  
AGANCIO TUBO-PARETE  
**6094/022**

lx 6095 €/u



**SOPORTE VIDRIO-TUBO**  
ARTICULADO  
SUPPORT TUBE-VERRE  
CONNEXION TUBE-GLASS  
AGANCIO TUBO-VETRO  
**6095/022**

lx 8-10 mm 6094 €/u



**TUBO CUADRADO DE 19X19**  
TUBE CARRÉ 19X19  
19X19 SQUARE TUBE  
TUBO QUADRATO 19X19  
**6093/222**  
**6093/322**

lx 2m / 3m €/u  
19x19x1mm



# BARRAS DE REFUERZO A MEDIDA

6090/022 + 6093 + 6087/022

OPCIÓN A



**Barra de refuerzo - pared 90° fija - a medida**  
Barre renfort personnalisée  
Fixing rod customized  
Barra di rinforzo su misura

6094/022 + 6093 + 6095/022

OPCIÓN B



**Barra de refuerzo - articulada - a medida**  
Barre renfort personnalisée  
Fixing rod customized  
Barra di rinforzo su misura

## EJEMPLOS DE APLICACIONES



**NUEVO**

## COTEK

HERRAJES PARA DUCHAS - ACCESSOIRES DE DOUCHE  
SCHOWER GLASS FITTINGS - ACCESSORI PER DOCCIA

### BARRA REFUERZO PERIMETRAL TUBO Ø 19

BARRE RENFORT PERIMETRAL  
PERIMETRAL FIXING ROD  
BARRA RINFORZO PERIMETRALE



## COTEK

HERRAJES PARA DUCHAS - ACCESSOIRES DE DOUCHE  
SCHOWER GLASS FITTINGS - ACCESSORI PER DOCCIA

	INOX BR INOX POLI P.S.S. INOX LUC	INOX SAT INOX SAT S.S.S. INOX SAT	PLASTICO PLASTIC PLASTICA	
	22	28	09	
	inox s.s.	8-10mm	Ø19mm	€/u
	o			
	inox s.s.	Ø 19x1 mm	2 m	€/u
	o			
	inox s.s.	Ø 19x1 mm	3 m	€/u
	o			
	inox s.s.	8-10mm	Ø19mm	€/u
	o			
	inox s.s.	8-10mm	Ø19mm	€/u
	o			
	inox s.s.	8-10mm	Ø19mm	€/u
	o			
	inox s.s.	8-10mm	Ø19mm	€/u
	o			
	inox s.s.	Ø19mm		€/u
	o			
	inox s.s.	Ø19mm		€/u
	o			
	inox s.s.			€/u
	o			

### BARRAS REFUERZO TECHO A MEDIDA

	+		+		
4090/022		4093		4086/022	
BARRAS DE REFUERZO A MEDIDA barre renfort personnalisée fixing rod customized barra di rinforzo su misura					

### BARRAS REFUERZO PARED 90° A MEDIDA

	+		+		
4090/022		4093		4087/022	
BARRAS DE REFUERZO A MEDIDA barre renfort personnalisée fixing rod customized barra di rinforzo su misura					

**COTEK**

HERRAJES PARA DUCHAS - ACCESSOIRES DE DOUCHE  
SCHOWER GLASS FITTINGS - ACCESSORI PER DOCCIA

CR. BRILLO	NEGRO	INOX BR	INOX SAT
CR. POLI	NOR	INOX POLI	INOX SAT
BR. CHR	BLACK	P.S.S.	S.S.S.
CR. LLUC.	NERO	INOX LLUC	INOX SAT
<b>32</b>	<b>0N</b>	<b>22</b>	<b>28</b>

**BARRA REFUERZO PERIMETRAL TUBO 30X10**

BARRE RENFORT PERIMETRAL  
PERIMETRAL FIXING ROD  
BARRA RINFORZO PERIMETRALE



TUBO 30X10  
TUBE 30X10  
TUBE 30X10  
TUBO 30X10  
**4260/122**

inox s.s.	6 m	30x10x1,5	€/m
-----------	-----	-----------	-----



ANCLAJE CARRIL-PARED  
FIXATION MUR-COULISSE  
CONNEXION WALL-TRACK  
CONNESSIONE PARETE-GUIDA  
**4264/022**

inox s.s.			€/u
-----------	--	--	-----



ANCLAJE TUBO-VIDRIO  
FIXATION VERRE-TUBE  
CONNEXION GLASS-TUBE  
CONNESSIONE VETRO-TUBO  
**4277/022**

inox s.s.			€/u
-----------	--	--	-----



ANCLAJE TUBO-VIDRIO  
FIXATION VERRE-TUBE  
CONNEXION GLASS-TUBE  
CONNESSIONE VETRO-TUBO  
**4279/022**

inox s.s.			€/u
-----------	--	--	-----



ANCLAJE TUBO-VIDRIO 90°  
FIXATION VERRE-TUBE 90°  
CONNEXION GLASS-TUBE 90°  
CONNESSIONE VETRO-TUBO90  
**4276/022**

inox s.s.			€/u
-----------	--	--	-----



ANCLAJE TUBO-VIDRIO 180°  
FIXATION VERRE-TUBE 180°  
CONNEXION GLASS-TUBE 180°  
CONNESSIONE TUBO-VETRO 180°  
**4278/022**

inox s.s.			€/u
-----------	--	--	-----



CONEXIÓN 90° CARRIL  
FIXATION COULISSE 90°  
TRACKS CONNEXION 90°  
CONNESSIONE GUIDE 90°  
**4267/0**

inox s.s.			€/u
-----------	--	--	-----

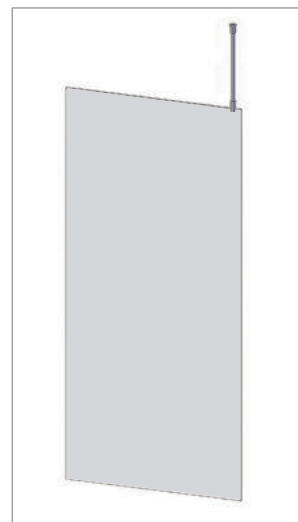
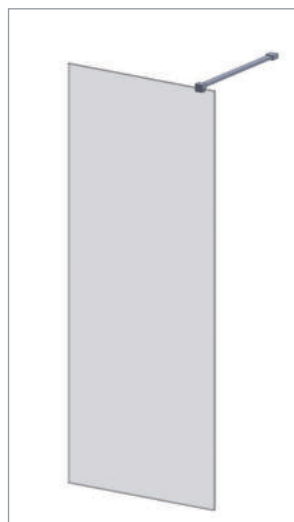
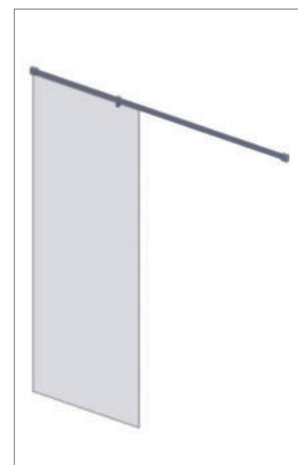
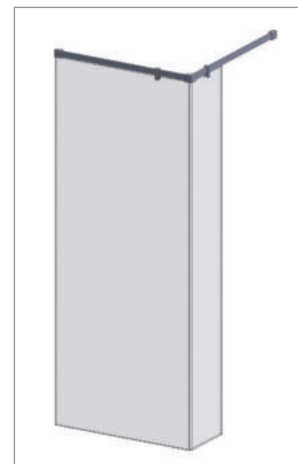
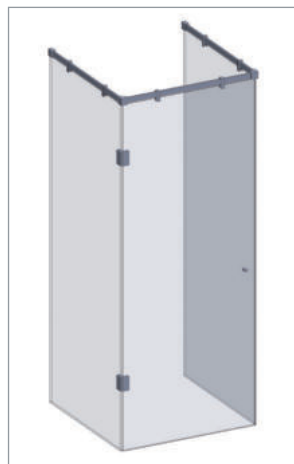

**BARRAS REFUERZO PARED 90° A MEDIDA**

**BARRAS REFUERZO TECHO A MEDIDA**

BARRAS DE REFUERZO A MEDIDA  
barre renfort personnalisé  
fixing rod customized  
barra di rinforzo su misura

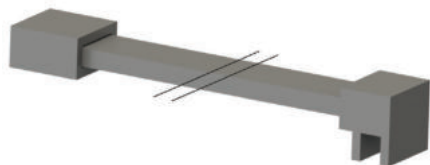

4264/022 + 4260/122 + 4276/022



4264/022  
+  
4260/122  
+  
4278/022

BARRAS DE REFUERZO A MEDIDA  
barre renfort personnalisé  
fixing rod customized  
barra di rinforzo su misura

**COTEK**

HERRAJES PARA DUCHAS - ACCESSOIRES DE DOUCHE  
SCHOWER GLASS FITTINGS - ACCESSORI PER DOCCIA

CR. BRILLO	CR. MATE	TITAN	INOX BR	INOX SAT
CHR. POLI	CHR. M	TITANE	INOX POLI	INOX SAT
BR. CHR	M. CHR	TITANUM	P.S.S.	S.S.S.
CR. LUC.	CR. OPAC	TITANO	INOX LUC	INOX SAT
32	31	06	22	28

**POMOS**

**NUEVOS POMOS Y ACABADOS**



TIRADOR DOBLE  
BOUTON DOUBLE  
DOUBLE KNOB  
POMOLO DOPPIO  
4124/Z32

Zn	6-10 mm	Ø29	Ø 8-10 mm	€/u
----	---------	-----	-----------	-----



TIRADOR DOBLE  
BOUTON DOUBLE  
DOUBLE KNOB  
POMOLO DOPPIO  
4124/Z35

ORO. MATE	MAT. DORE
MAT. GOLD	DOR. OPP
35	



TIRADOR DOBLE  
BOUTON DOUBLE  
DOUBLE KNOB  
POMOLO DOPPIO  
4124/Z0N

NEGRO	NOIR
BLACK	NERO
0N	

**! NUEVO**



TIRADOR DOBLE  
BOUTON DOUBLE  
DOUBLE KNOB  
POMOLO DOPPIO  
1824/0..

inox s.s.	6-10 mm	Ø25x32	Ø 10 mm	€/u
-----------	---------	--------	---------	-----



TIRADOR DOBLE  
BOUTON DOUBLE  
DOUBLE KNOB  
POMOLO DOPPIO  
4121/0..

inox s.s.	6-10 mm	25x25	Ø 8 mm	€/u
-----------	---------	-------	--------	-----

**! NUEVO**



TIRADOR DOBLE  
BOUTON DOUBLE  
DOUBLE KNOB  
POMOLO DOPPIO  
4123/Z32  
4123/Z0N

Zn	6-10 mm	30x32	Ø 8 mm	€/u
----	---------	-------	--------	-----

NEGRO	NOIR
BLACK	NERO
0N	



TIRADOR DOBLE  
BOUTON DOUBLE  
DOUBLE KNOB  
POMOLO DOPPIO  
4122/032  
4122/00N

Al	6-12 mm	30x25	Ø 10 mm	€/u
----	---------	-------	---------	-----



TIRADOR DOBLE  
BOUTON DOUBLE  
DOUBLE KNOB  
POMOLO DOPPIO  
4281/00N negro

Zn	6-10 mm	Ø45x28	Ø 12 mm	€/u
----	---------	--------	---------	-----

**! NUEVO**



TIRADOR DOBLE  
BOUTON DOUBLE  
DOUBLE KNOB  
POMOLO DOPPIO  
4119/032  
\*4119/031 latón

Zn	6-10 mm	Ø45x28	Ø 12 mm	€/u
----	---------	--------	---------	-----

**COTEK**

HERRAJES PARA DUCHAS - ACCESSOIRES DE DOUCHE  
SCHOWER GLASS FITTINGS - ACCESSORI PER DOCCIA

CR. BRILLO	CR. MATE	TITAN	INOX BR	INOX SAT
CHR. POLI	CHR. M	TITANE	INOX POLI	INOX SAT
BR. CHR	M. CHR	TITANUM	P.S.S.	S.S.S.
CR. LUC.	CR. OPAC	TITANO	INOX LUC	INOX SAT
32	31	06	22	28



TIRADOR DOBLE  
BOUTON DOUBLE  
DOUBLE KNOB  
POMOLO DOPPIO  
1584/032  
1584/006

Al	6-12 mm	Ø48x43	Ø 10 mm	€/u
----	---------	--------	---------	-----

NEGRO	NOIR
BLACK	NERO
0N	

**MANILLAS INOX**

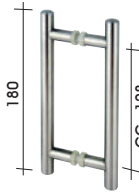

MANILLA DOBLE  
POIGNÉE DOUBLE  
DOUBLE DOOR PULL  
MANIGLIA DOPPIA  
4127/0..

inox s.s.	6-10 mm	Ø14	€/u
		2 x Ø 10 mm	CC=128 mm

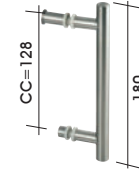

MANILLA + POMO  
POIGNÉE + BOUTON  
DOOR PULL + KNOB  
MANIGLIA + POMOLO  
\*4128/0..

inox s.s.	6-10 mm	Ø14	€/u
		2 x Ø 10 mm	CC=128 mm

**MANILLAS CROMADAS**



MANILLA DOBLE  
POIGNÉE DOUBLE  
DOUBLE DOOR PULL  
MANIGLIA DOPPIA  
4139/Z32  
4139/Z0N negro

Zn	6-10 mm	226x34	€/u
		2 x Ø 6 mm	CC=220 mm

**MANILLAS ALUMINIO**



MANILLA DOBLE  
POIGNÉE DOUBLE  
DOUBLE DOOR PULL  
MANIGLIA DOPPIA  
4129/A32  
4129/A0N negro

Al	6-10 mm	259x13	€/u
		2 x Ø 8 mm	CC=220 mm

**! NUEVO**

**TIRADOR-TOALLERO**



MANILLA + TOALLERO  
POIGNÉE + SERVIETTE  
HANDLE WITH TOWEL BAR  
MANIGLIONE CON PORTA  
ASCIUGAMANO  
4131/022

inox s.s.	6-12 mm	Ø19	€/u
		3 x Ø 9 mm	CC=433 mm CC=131 mm



POMO + TOALLERO  
POIGNÉE + SERVIETTE  
KNOB WITH TOWEL BAR  
POMULO CON PORTA  
ASCIUGAMANO  
1891/022  
1891/00N

inox s.s.	8-10 mm	25x25	€/u
		2 x Ø8 - Ø10 mm	CC=450 mm

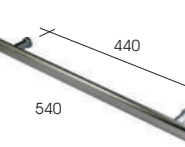

TIRADOR TOALLERO  
BARRA RECTANGULAR  
MANILLA + TOALLERO  
POIGNÉE + SERVIETTE  
HANDLE WITH TOWEL BAR  
MANIGLIONE CON PORTA  
ASCIUGAMANO  
5960/032

Zn	inox s.s.	6-10 mm	€/u
		2 x Ø 8 mm	CC= 440 mm



# COTEK

HERRAJES PARA DUCHAS - ACCESSOIRES DE DOUCHE  
SCHOWER GLASS FITTINGS - ACCESSORI PER DOCCIA

PL. MATE ANOD. M AN. CR. AN. CPAC	NEGRO NOIR BLACK NERO	INOX BR INOX POLI P.S.S. INOX LUC	INOX SAT INOX SAT S.S.S. INOX SAT
01	0N	22	28

## UÑEROS PUERTAS CORREDERAS



UÑERO DOBLE ADHESIVO  
POIGNEÉ DOUBLE ADHESIVE  
DOUBLE ADHESIVE PULL  
POMO DOPPIO ADHESIVO  
4207/0..

Ø 60		€/U
Al		o
Al		o
Al		o
Al		o



GALGA MONTAJE UÑEROS  
GABARIT DE MONTAGE  
INSTALLATION TOOL  
SAGOMA AIUTO MONTAGGIO  
4209/000

Al	€/U
o	

## UÑERO 4207 - NEGRO MATE



UÑERO DOBLE ADHESIVO  
POIGNEÉ DOUBLE ADHESIVE  
DOUBLE ADHESIVE PULL  
POMO DOPPIO ADHESIVO  
4207/00N

lx Ø 60		€/U
o		

UÑERO DOBLE ADHESIVO  
POIGNEÉ DOUBLE ADHESIVE  
DOUBLE ADHESIVE PULL  
POMO DOPPIO ADHESIVO  
4337/028  
4337/00N

inox s.s.	8-12mm	Ø 46mm	€/U
o			

**! NUEVO**

TOPE PARA PUERTA DE VIDRIO  
ARRÊT DE PORTE EN VERRE  
GLASS DOOR STOP  
FERMAPORTA IN VETRO  
4953/032

Cu	6-8 mm	€/U
CR. BRILLO CR. POLI BR. CR. CR. LUC.	32	o

**! NUEVO**

# COTEK

HERRAJES PARA DUCHAS - ACCESSOIRES DE DOUCHE  
SCHOWER GLASS FITTINGS - ACCESSORI PER DOCCIA

CR. BRILLO CR. POLI BR. CR. CR. LUC.	PL. BR ALU. BR ALL. LUC	PLÁSTICO PLASTIQUE PLASTIC PLASTICA
32	02	09

## TAPAJUNTAS

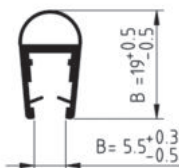

TAPAJUNTA LATERAL BURBUJA  
PROFIL ÉTANCHEITÉ LATERAL  
LATERAL SEAL  
GIUNTA LATERALE

1830/109 6-8mm

pvc	2,2m	6-8mm	€/m
o			

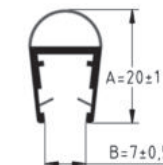

1833/109 8-10mm

pvc	2,2m	8-10mm	€/m
o			

1833/139 8-10mm

pvc	3m	8-10mm	€/m
o			

TAPAJUNTA INFERIOR Y LATERAL  
PROFIL ÉTANCHEITÉ INFERIOR ET LATERAL  
BOTTOM AND LATERAL SEAL  
GIUNTA INFERIORE E LATERALE

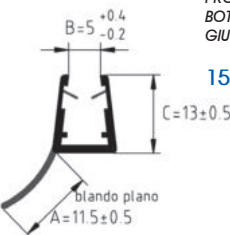

1586/109 6-8mm

pvc	2,2m	6-8mm	€/m
o			

TAPAJUNTA INFERIOR Y LATERAL  
PROFIL ÉTANCHEITÉ INFERIOR ET LATERAL  
BOTTOM AND LATERAL SEAL  
GIUNTA INFERIORE E LATERALE

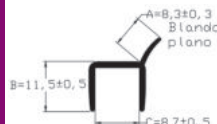

1587/109 10 mm

pvc	2,2m	10mm	€/m
o			

**! NUEVO**

TAPAJUNTA INFERIOR  
PROFIL ÉTANCHEITÉ INFERIOR  
BOTTOM SEAL  
GIUNTA INFERIORE

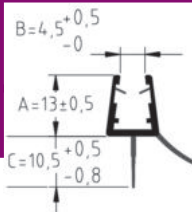

1854/109 6-8mm

pvc	2,2m	6-8mm	€/m
o			

pvc	2,2m	10-12mm	€/m
o			

TAPAJUNTA INFERIOR Y LATERAL  
PROFIL ÉTANCHEITÉ INFERIOR ET LATERAL  
BOTTOM AND LATERAL SEAL  
GIUNTA INFERIORE E LATERALE

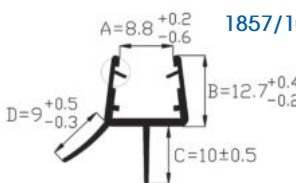

1857/109 10-12mm

PERFIL INFERIOR  
PROFIL ÉTANCHEITÉ  
SEAL  
GIUNTA

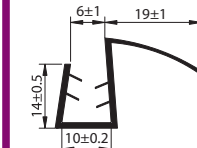

1856/109

pvc	2,2m	8-10mm	€/m
o			

**! NUEVO**

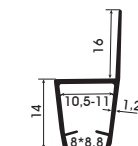

TAPAJUNTA INFERIOR Y LATERAL  
PROFIL ÉTANCHEITÉ INFERIOR ET LATERAL  
BOTTOM AND LATERAL SEAL  
GIUNTA INFERIORE E LATERALE

\*1869/209 10 mm (ala 16 mm)

pvc	2,2m	10mm	€/U
o			



## COTEK

HERRAJES PARA DUCHAS - ACCESSOIRES DE DOUCHE  
SCHOWER GLASS FITTINGS - ACCESSORI PER DOCCIA

### TAPAJUNTAS IMANTADOS

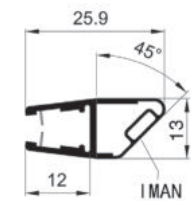

PERFIL CON IMÁN 90°/180°  
PROFIL ÉTANCHEITÉ MAGNETIQUE 90°/180°  
MAGNETIC SEAL 90°/180°  
GIUNTA MAGNETICA 90°/180°

IMAN DERECHA  
\*1828/109 6-8 mm  
droite/right/destra



IMAN IZQUIERDA  
\*1829/109 6-8 mm  
gauche/left/sinistra

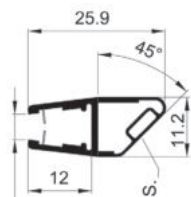

CONJUNTO DE TAPAJUNTAS  
DER./IZQ. CON IMÁN  
PROF. ÉTANCHEITÉ MAGNET.  
MAGNETIC SEAL  
GIUNTA MAGNETICA

Set derecha + izquierda  
Set droite + gauche  
Set right + left  
Set destra + sinistra

1866/209 8 mm

1867/209 10 mm

1868/209 6 mm

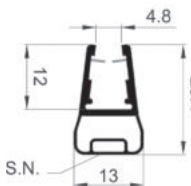
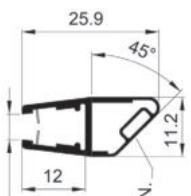

PERFIL CON IMÁN 180°  
PROFIL ÉTANCHEITÉ MAGNETIQUE 180°  
MAGNETIC SEAL 180°  
GIUNTA MAGNETICA 180°

1827/109 6-8mm



4 taladros hechos para fijación a pared

PERFIL ALUM. X TAPAJUNTAS  
ALUM. PROF. ÉTANCHEITÉ  
ALUM. PROF. SEAL  
PROF. ALLUMINIO, GIUNTA

5962/202 12,5x10x12,5x1

13



Puerta con perfil 5962 + tapajuntas magnéticas. A pared

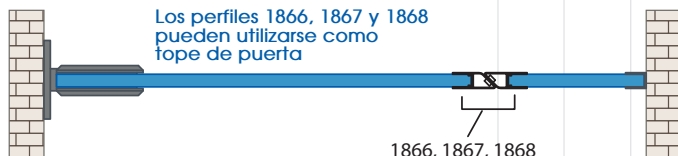

Los perfiles 1866, 1867 y 1868 pueden utilizarse como tope de puerta

### TAPAJUNTAS ADHESIVAS

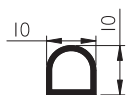

TAPAJUNTA ADHESIVO 2,2 M  
PROFIL ÉTANCHEITÉ ADHÉSIF 2,2M  
ADHESIVE SEAL 2,2 M  
GIUNTA ADESIVA 2,2 M

1810/109 8-10 mm



TAPAJUNTA ADHESIVO 2,5 M  
PROFIL ÉTANCHEITÉ ADHÉSIF 2,5M  
ADHESIVE SEAL 2,5 M  
GIUNTA ADESIVA 2,5 M

1811/109 8-10 mm

CR. BRILLO CHR. POLI BR. CHR CR. LUC.	PL. BR ALU. BR ALL. LUC	PLÁSTICO PLASTIQUE PLASTIC PLASTICA
32	02	09

pvc	2,2m	6-8mm	€/m
-----	------	-------	-----

pvc	2,2m	8-10mm	€/u
-----	------	--------	-----

pvc	2,2m	6-8mm	€/m
-----	------	-------	-----

Al	1,95 m	€/u
Para juntas de 10mm grosor		

## COTEK

HERRAJES PARA DUCHAS - ACCESSOIRES DE DOUCHE  
SCHOWER GLASS FITTINGS - ACCESSORI PER DOCCIA

### TAPAJUNTAS CORREDERA

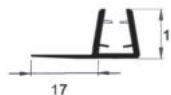

PERFIL LATERAL CORREDERA  
PROFIL ÉTANCHEITÉ COULISSENT  
SLIDING DOOR SEAL  
GIUNTA PORTA SCORREVOLE

1852/209 8 mm

1853/209 10 mm

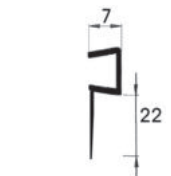

PERFIL LATERAL CORREDERA  
PROF. ÉTANCHEITÉ COULISSENT  
SLIDING DOOR SEAL  
GIUNTA PORTA SCORREVOLE

1851/109

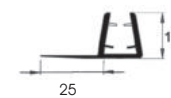

PERFIL LATERAL CORREDERA  
PROF. ÉTANCHEITÉ COULISSENT  
SLIDING DOOR SEAL  
GIUNTA PORTA SCORREVOLE

1839/209

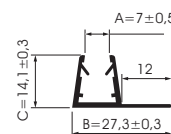

PERFIL LATERAL CORREDERA  
PROF. ÉTANCHEITÉ COULISSENT  
SLIDING DOOR SEAL  
GIUNTA PORTA SCORREVOLE

1855/109

**NUEVO**

### TAPAJUNTAS PLEGABLE

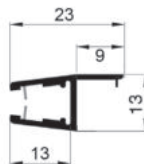

PERFIL LATERAL CON TOPE  
PROFIL LATERAL ÉTANCHEITÉ AVEC ARRÊT  
LATERAL SEAL WITH STOP  
PROFILO LATERALE CON ARRESTO

1834/109

### BURLETE ALUMINIO SUELO



PERFIL BURLETE VIERTIAGUAS  
PROFIL SEUIL  
PROFILE THRESHOLD  
PROFILO VERTIACQUE

1831/202

1831/20N

### BURLETE ADHESIVOS PLÁSTICO SUELO



PERFIL BURLETE ADHESIVO VIERTIAGUAS  
PLÁSTICO CROMADO  
PROFIL SEUIL ADHÉSIF  
Plastic chromé brillant  
ADHESIVE PROFILE THRESHOLD  
Plastic chromed  
PROFILO ADESIVO VERTIACQUE  
Plastica finitura cromo

1832/132



PERFIL BURLETE ADHESIVO VIERTIAGUAS  
PROFIL SEUIL ADHÉSIF  
ADHESIVE PROFILE THRESHOLD  
PROFILO ADESIVO VERTIACQUE

\*1841/132

CR. BRILLO CHR. POLI BR. CHR CR. LUC.	PL. BR ALU. BR ALL. LUC	PLÁSTICO PLASTIQUE PLASTIC PLASTICA
32	02	09

pvc	2,2m	8-10mm	€/u
-----	------	--------	-----

pvc	2,2m	8mm	€/m
-----	------	-----	-----

pvc	2,2m	8-10mm	€/u
-----	------	--------	-----

pvc	2,2m	8-10mm	€/m
-----	------	--------	-----

pvc	3m	10mm	€/m
-----	----	------	-----

Al	2 m	21x6,5	€/u
----	-----	--------	-----

pvc	2 m	10x4	€/m
-----	-----	------	-----

pvc	2 m	11x9	€/m
-----	-----	------	-----

NEGRO  
NOIR  
BLACK  
NERO  
ON

**COTEK - ÍNDEX****PUERTAS DE PASO - CORREDERAS**

<b>1- PREMIUM PUERTAS</b>	<b>51</b>
Selección de herrajes de alta gama	
A. PUERTA AUTOMÁTICA PANAMÁ	
<b>2- PLEGABLE</b>	<b>55</b>
<b>3- KOBE</b>	<b>59</b>
<b>4- KYOTO</b>	<b>61</b>
<b>5- CANTON</b>	<b>63</b>
<b>6- CANTON MARCO /     CANTON MARCO TELEX</b>	<b>65</b>
<b>7- SERENA</b>	<b>87</b>
<b>8- SYNCRO</b>	<b>89</b>
<b>9- TELEX</b>	<b>91</b>
<b>10- TOKYO</b>	<b>95</b>
<b>11- SHANGHAI</b>	<b>96</b>
<b>12- PLATEK</b>	<b>97</b>
<b>13- PISA / MONZA / RIMINI</b>	<b>99</b>
<b>14- VIGO</b>	<b>112</b>

## COTEK - ÍNDEX

### PUERTAS DE PASO - ABATIBLES

#### 1- PREMIUM (HIDRÁULICAS) 115 Selección de herraje de alta gama

**A. AMSTERDAM** Freno pivotante sin empotrar inox 304

100kg vidrio 8-12 mm

**B. MIAMI** Freno pivotante sin empotrar inox 316 150kg

vidrio 8-12 mm

**C. BOSTON** Freno pivotante sin empotrar fuerza 7 para

puertas exteriores inox 316 100kg vidrio 8-12 mm

**D. PRAGA** Bisagra hidráulica a pared con retención

inox 304, vidrio 8-10 mm 30 kg/u

**E. OPORTO** Bisagra hidráulica a pared con retención

aluminio, vidrio 8-10 mm 20/30 kg/u

#### 2- HIDRÁULICAS / AUTOMÁTICAS 117

#### 3- FRENOS / MARINA / PLINTO / MALAGA 119

#### 4- CANTON PIVOTANTE 121

#### 5- PERFIL PUERTAS / DIVISORIAS 125

#### 6- CERRADURAS 127

#### 7- TIRADORES 129

SERIE PREMIUM

# PUERTA AUTOMÁTICA PANAMÁ

SISTEMA DE RODILLOS DESLIZANTES DE ACCIONAMIENTO ELECTROMAGNÉTICO

MÚLTIPLES MODOS DE APERTURA PARA ELEGIR



INTERRUPTOR INFRARROJO



INTERRUPTOR DE SENSORES



INTERRUPTOR DE SENSORES



INTERRUPTOR TÁCTIL



INTERRUPTOR DE HUELLAS DACTILARES (SOBRE PEDIDO)



ACCESORIOS DEL PRODUCTO

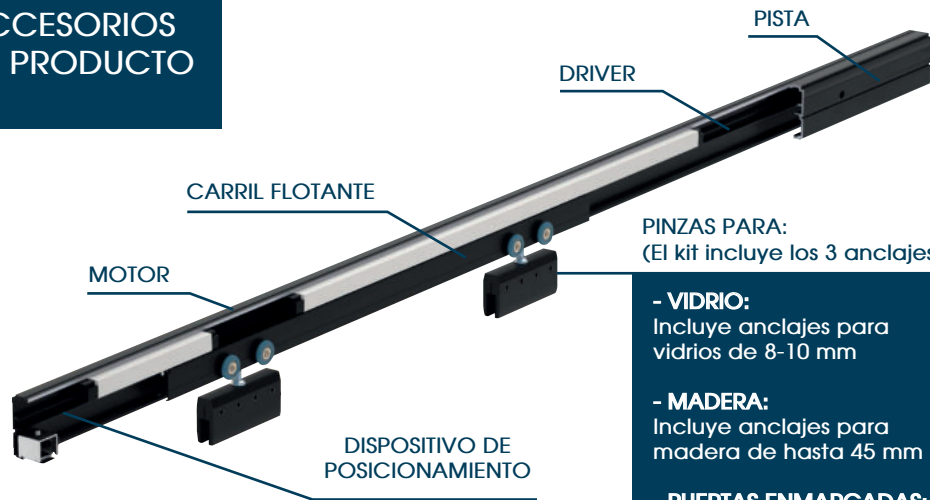

PINZAS PARA: (El kit incluye los 3 anclajes)

- VIDRIO: Incluye anclajes para vidrios de 8-10 mm
- MADERA: Incluye anclajes para madera de hasta 45 mm
- PUERTAS ENMARCADAS: Incluye anclajes para puerta Canton Marco.

Serie PREMIUM

**SERIE PREMIUM**

# PUERTA AUTOMÁTICA PANAMÁ

SISTEMA DE RODILLOS DESLIZANTES DE ACCIONAMIENTO ELECTROMAGNÉTICO

**VENTAJAS DEL PRODUCTO**



**SOBRE PEDIDO**  
se puede conseguir puertas eléctricas telescópicas y/o sincronizadas.

**SEGURIDAD:**

- ANTI-PELLIZCO —
- EXCELENTE FUNCIÓN DE RETORNO DE SEGURIDAD. —
- LA PUERTA HARÁ UN MOVIMIENTO INVERSO CUANDO EL CUERPO HUMANO O UN OBSTÁCULO GOLPEEN LA PUERTA —



Anti-pelliczo



Movimiento silencioso



Seguridad y ahorro de energía

**Serie PREMIUM**

**SERIE PREMIUM**

# PUERTA AUTOMÁTICA PANAMÁ

SISTEMA DE RODILLOS DESLIZANTES DE ACCIONAMIENTO ELECTROMAGNÉTICO

**CON MOTOR MAGNÉTICO SILENCIOSO**

- AVEC MOTEUR MAGNÉTIQUE SILENCIEUX
- WITH SILENT MAGNETIC MOTOR
- CON MOTORE MAGNETICO SILENZIOSO

**al** Aluminio anodizado negro

 8-10 mm

 80 kg/u

 Kits para puertas de ente 80-140 cm

 Solo montaje a pared



**CARACTERÍSTICAS DEL PRODUCTO**

- Ajuste de altura 5mm
- Ruido ≤ 40dB
- Standby consumo ≤ 5w
- Consumo ≤ 100w
- Velocidad cierre 200-500 mm/sec
- Tensión 220v/110v
- Certificaciones:



**PIEZAS KIT**

- 1u. Perfil aluminio con motor electromagnético 3m
- 1u. Tapa perfil aluminio 3m
- 1u. Soporte magnético porta pinzas con 2 pinzas para vidrio
- 2u. Stop guía superior
- 1u. Guía inferior



**PUERTA PULSADOR INALÁMBRICO**

2u. pulsadores (taladro Ø52mm)

- 800-1000 mm **4080/31N** ○
- 1000-1200 mm **4080/32N** ○
- 1200-1400 mm **4080/34N** ○

€/u



**PUERTA SENSOR LARGA DISTANCIA**

2u. sensores

- 800-1000 mm **4081/31N** ○
- 1000-1200 mm **4081/32N** ○
- 1200-1400 mm **4081/34N** ○

€/u



**\* PUERTA SENSOR INFRAROJO**

2u. sensores

- 800-1000 mm **\*4082/31N** ○
- 1000-1200 mm **\*4082/32N** ○
- 1200-1400 mm **\*4082/34N** ○

€/u

**Serie PREMIUM**

**SERIE PREMIUM**

**PRODUCTO MEJORADO**

\* CONSULTA LAS NUEVAS MEDIDAS DEL PRODUCTO ACTUALIZADO

**ANCLAJE A TECHO**

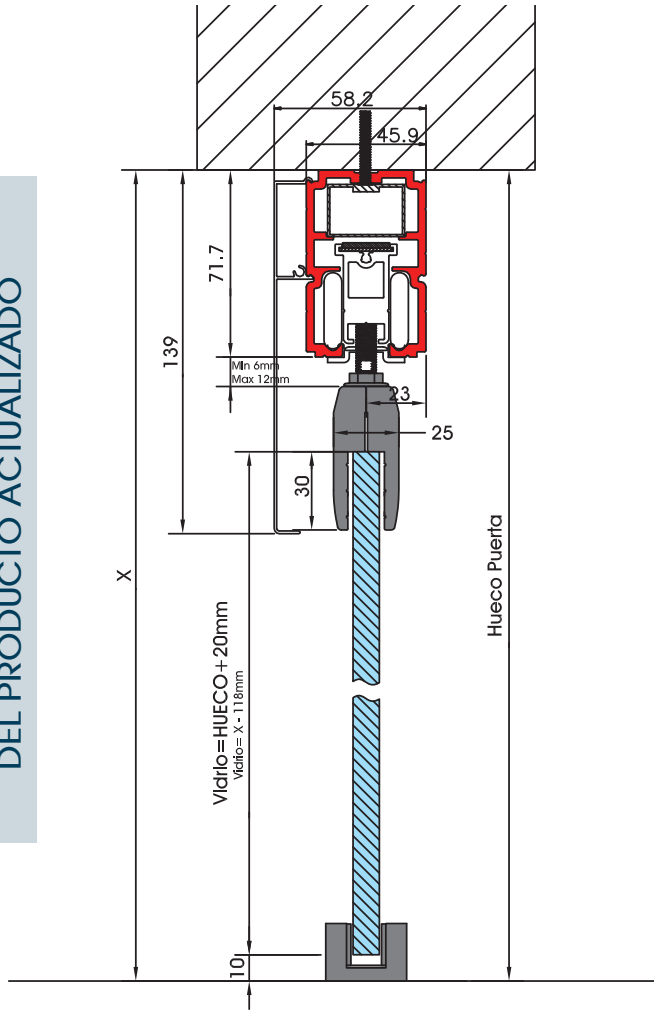

**ANCLAJE A PARED**

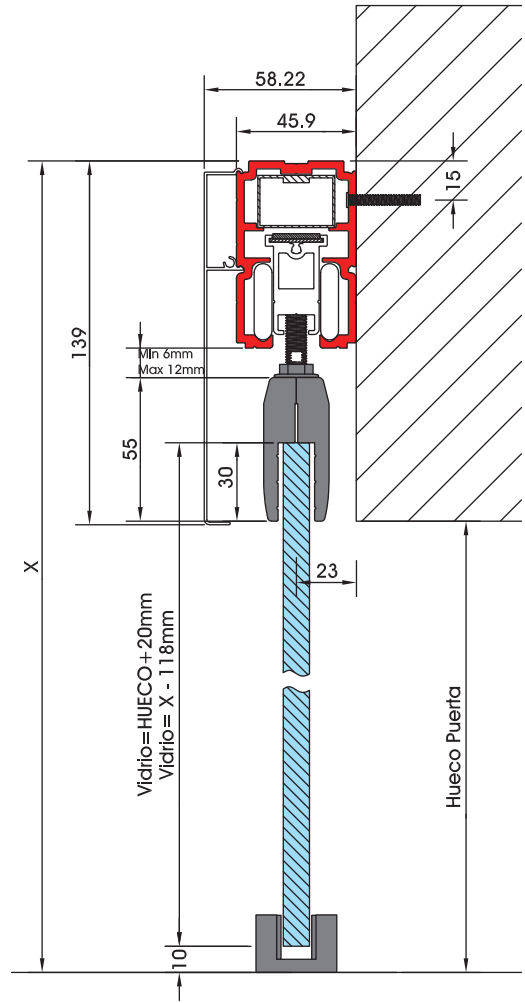

Escoger el carril magnetico dependiendo del ancho de la puerta

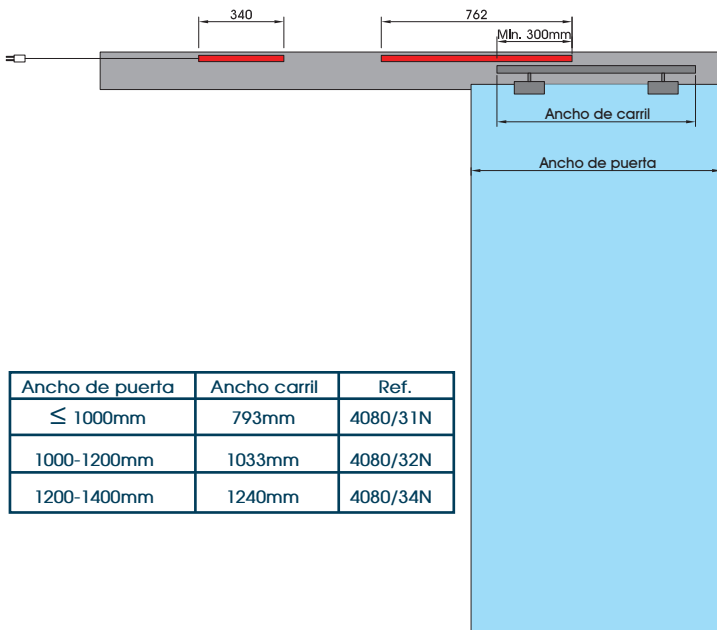

Ancho de puerta	Ancho carril	Ref.
≤ 1000mm	793mm	4080/31N
1000-1200mm	1033mm	4080/32N
1200-1400mm	1240mm	4080/34N

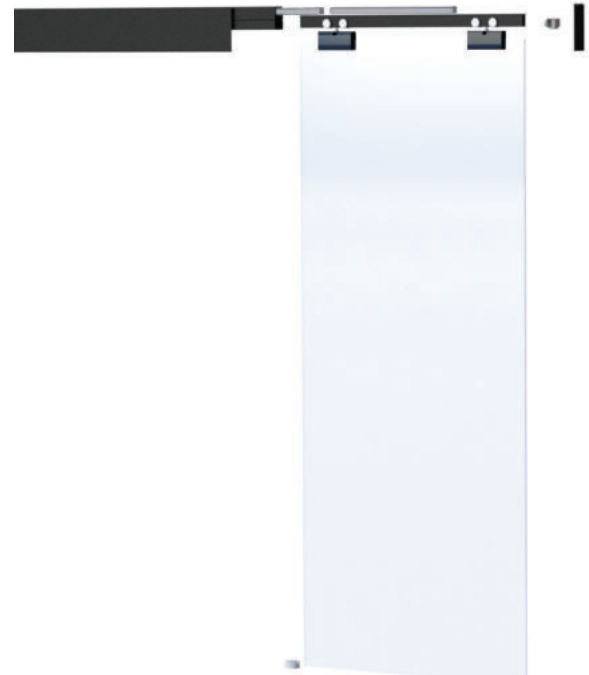

**Serie PREMIUM**

# COTEK - PLEGABLE

PUERTAS PLEGABLES ACORDEÓN - SYSTÈME DE PORTE ACCORDÉON  
FOLDING DOOR SYSTEM - PORTE A LIBRO

## PLEGABLE

### ALUMINIO E INOX

ALUMINIUM ET ACIER INOXYDABLE  
ALUMINIUM AND STAINLESS STEEL  
ALLUMINIO E ACCIAIO INOSSIDABILE

- espesor vidrio: 10-12 mm templado
- ancho maximo hoja: 960 mm
- alto maximo hoja recom.: 2600 mm
- peso max.: 80 kg/hoja
- se recomienda max. 6 hojas continuas
- precisa muecas en los vidrios.
- sin carril en el suelo
- sistema no estanco

- pods-limite porte: 80 kg
- large-limite porte: 960 mm
- Hauteur-limite porte: 2600 mm
- max. rec. 6 portes/kit
- verre 10-12 mm trempé
- encoches
- sans guide du sol
- no étanchéité
- weight max. door: 80 kg
- width max. door: 960 mm
- height max. door: 2600 mm
- max. rec. 6 doors/kit
- glass 10-12 mm tempered
- cut-out
- without floor guide
- not stagnancy
- peso max. porta: 80 kg
- larghezza max. porta: 960 mm
- altezza max. porta: 2600 mm
- max. rec. 6 porte/kit
- vetro 10-12 mm temperato
- Tacca nel vetro
- Senza guida a terra
- non a tenuta stagna

### PRESUPUESTOS

1. escoger la configuración
2. indicar medida de hueco y alto.
3. indicar acabado (en stock plata mate)
4. enviar por e-mail ó fax la solicitud (si es posible con un croquis)

#### ESTIMATIONS

1. choisir la configuration
2. indiquer la taille de l'ouverture et de la hauteur.
3. indiquer finition (stock: aluminium anod.naturel)
4. envoyer par e-mail ou par le fax le demande (si possible avec un croquis)

#### QUOTATIONS

1. choose the configuration
2. indicate opening size and height.
3. indicate finish (aluminium natural anod. in stock)
4. send by e-mail or by fax the requirement (if possible with a sketch)

#### PREVENTIVI

1. scegliere la configurazione
2. indicare le dimensioni di apertura e l'altezza.
3. indicare finitura (stock: alluminio anod.naturale)
4. inviare via e-mail o fax la richiesta (se possibile con uno schizzo)



ref. 4482/001



Al L 5,8 m

GUÍA SUPERIOR  
COULISSE HAUTE  
UPPER TRACK  
GUIDA SUPERIOR  
4460/101

inox s.s. Al plas 80 kg/u

COJINETE  
GALET  
ROLLER  
PATTINO SCORREVOLE  
4465/000

inox s.s. Al 80 kg/u

GIRO SUPERIOR PIVOTANTE  
PIVOT SUPERIEUR  
UPPER PIVOTING HINGE  
CERNIERA PIVOTANTE SUPERIORE  
4466/000

inox s.s. Al 80 kg/u

GIRO INFERIOR PIVOTANTE  
PIVOT INFÉRIEUR  
BOTTOM PIVOTING HINGE  
CERNIERA PIVOTANTE INFERIORE  
4467/000

Al L 3 m

CASACA VIDRIO  
PROFIL VERRE  
PROFILE GLASS  
PROFILO VETRO  
4461/101

Al L 1,2 m

CASACA VIDRIO X CERRADURA  
PROFIL VERRE X SERRURE  
PROFILE GLASS X LOCK  
PROFILO VETRO X SERRATURA  
4462/001

inox s.s. Al Zn

CERRADURA DISTINTA LLAVE  
SERRURE COMBINAISONS DIFFÉRENTES  
LOCK DIFFERENT KEYED  
SERRATURA COMBINAZIONI DISTINTE  
4462/L01  
MISMA LLAVE: CONSULTAR  
MÊME COMBINAISON: CONSULTE  
KEYD ALIKE: CONSULTE  
STESSA COMBINAZIONE: CONSULTARE

Al L 1,2 m

CASACA VIDRIO X PESTILLO LATERAL  
PROFIL VERRE X VERROULATÉRALE  
PROFILE GLASS X LATERAL BOLT  
PROFILO VETRO X CHIAVISTELLO LATERALE  
4468/001

inox s.s. Al Zn

PESTILLO LATERAL  
VERROULATÉRALE  
LATERAL BOLT  
CHIAVISTELLO LATERALE  
4468/B01

inox s.s.

CUBILETE  
GÂUCHE  
STRIKE PATCH  
CONTROSERRATURA  
4463/022

inox s.s. plas Ø 25

ANCLAJE VIDRIO-CASACA 4461  
CONNEXION VERRE-PERFIL 4461  
CONNESSION GLASS-PROFIL 4461  
CONNESSIONE VETRO-PROFILO 4461  
4471/000

inox s.s. Al

BISAGRA X 4461  
CHARNIÈRE X 4461  
HINGE X 4461  
CERNIERA X 4461  
4469/001

inox s.s. Al

TAPA FINAL CASACA  
EMBOUT X 4461  
END-CAP X 4461  
COPRITESTA X 4461  
4470/001

inox s.s. plas

CEPILLO  
BROSSER  
BRUSH  
SPAZZOLA  
4474/200 12 mm

Al plas

TOPE SUELO  
ARRETEZ DE PORTE DU SOL  
DOOR STOPPER  
STOP SUOLO  
4464/022

inox s.s. plas

RETENCIÓN PUERTAS SUELO  
RÉTENTION PORTES  
DOORS RETENTION  
RITENZIONE PORTE  
4473/022

TORNILLOS  
VIS  
SCREWS  
VITI  
4477/000

LLAVE  
OUTIL  
TOOL x SCREWS  
UTENSILE REGOLABILE x VITI  
4472/034



# COTEK - PLEGABLE

PUERTAS PLEGABLES ACORDEÓN - SYSTÈME DE PORTE ACCORDEÓN  
FOLDING DOOR SYSTEM - PORTE A LIBRO

KIT	4480/001	4481/001	4482/001	4483/001	4484/001	4485/001	4486/001	4487/001	4488/001	4489/001
PUERTAS PORTES DOORS PORTE	2	2+1	3	3+1	4	4+1	5	5+1	6	6+1
ANCHO mm LARGEUR WIDTH LARGHEZZA	1510	2490	2490	3460	3460	4440	4440	5400	5400	6380 max.
										consultar

**4480/001**  
max. 1510 mm  
2 puertas



- 4465/000 cojinete carril sup. 1 u
- 4466/000 giro sup. 1 u
- 4469/001 bisagra 2 u
- 4467/000 giro inf. 1 u
- 4473/022 bloqueo puerta 1 u
- 4472/034 llave montaje 1 u
- 4461/101 casaca 2 m
- 4462/101 casaca + cerradura 2 u
- 4460/101 carril sup. 1,5 m
- 4463/022 cubilete 1 u
- 4464/022 tope suelo 1 u
- 4471/000 fijador vidrio/casaca 8 u
- 4474/000 cepillo 6 m
- 4470/001 tapas finales casaca 4 u
- 1833/109 tapajunta final 6 m
- 1834/109 tapajunta intermedio 3 m

**4485/001**  
max. 4440 mm  
4+1 puertas



- 4465/000 cojinete carril sup. 3 u
- 4466/000 giro sup. 2 u
- 4469/001 bisagra 6 u
- 4467/000 giro inf. 2 u
- 4473/022 bloqueo puerta 4 u
- 4472/034 llave montaje 1 u
- 4461/101 casaca 6 m
- 4462/101 casaca + cerradura 1 u
- 4468/101 casaca + pestillo 2 u
- 4460/101 carril sup. 5,8 m
- 4463/022 cubilete 3 u
- 4464/022 tope suelo 2 u
- 4471/000 fijador vidrio/casaca 20 u
- 4474/000 cepillo 18 m
- 4470/001 tapas finales casaca 8 u
- 1833/109 tapajunta final 9 m
- 1834/109 tapajunta intermedio 9 m

**4481/001**  
max. 2490 mm  
2+1 puertas

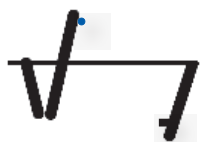

- 4465/000 cojinete carril sup. 1 u
- 4466/000 giro sup. 2 u
- 4469/001 bisagra 2 u
- 4467/000 giro inf. 2 u
- 4473/022 bloqueo puerta 2 u
- 4472/034 llave montaje 1 u
- 4461/101 casaca 3 m
- 4462/101 casaca x cerradura 1 u
- 4468/101 casaca x pestillo 1 u
- 4460/101 carril sup. 2,5 m
- 4463/022 cubilete 2 u
- 4464/022 tope suelo 2 u
- 4471/000 fijador vidrio/casaca 12 u
- 4474/000 cepillo 5 u
- 4470/001 tapas finales casaca 8 u
- 1833/109 tapajunta final 6 m
- 1834/109 tapajunta intermedio 3 m

**4486/001**  
max. 4440 mm  
5 puertas



- 4465/000 cojinete carril sup. 4 u
- 4466/000 giro sup. 1 u
- 4469/001 bisagra 8 u
- 4467/000 giro inf. 1 u
- 4473/022 bloqueo puerta 1 u
- 4472/034 llave montaje 1 u
- 4461/101 casaca 7 m
- 4462/101 casaca + cerradura 1 u
- 4468/101 casaca + pestillo 1 u
- 4460/101 carril sup. 5,8 m
- 4463/022 cubilete 2 u
- 4464/022 tope suelo 1 u
- 4471/000 fijador vidrio/casaca 20 u
- 4474/000 cepillo 18 m
- 4470/001 tapas finales casaca 4 u
- 1833/109 tapajunta final 6 m
- 1834/109 tapajunta intermedio 12 m

**4482/001**  
max. 2490 mm  
3 puertas



- 4465/000 cojinete carril sup. 2
- 4466/000 giro sup. 1
- 4469/001 bisagra 4
- 4467/000 giro inf. 1
- 4473/022 bloqueo puerta 1
- 4472/034 llave montaje 1
- 4461/101 casaca 4
- 4462/101 casaca + cerradura 1
- 4460/101 carril sup. 2,5
- 4463/022 cubilete 1
- 4464/022 tope suelo 1
- 4471/000 fijador vidrio/casaca 12
- 4474/000 cepillo 5
- 4470/001 tapas finales casaca 4
- 1833/109 tapajunta final 6 m
- 1834/109 tapajunta intermedio 6 m

**4487/001**  
max. 5400 mm  
5+1 puertas



- 4465/000 cojinete carril sup. 4 u
- 4466/000 giro sup. 2 u
- 4469/001 bisagra 8 u
- 4467/000 giro inf. 2 u
- 4473/022 bloqueo puerta 2 u
- 4472/034 llave montaje 1 u
- 4461/101 casaca 8 m
- 4462/101 casaca + cerradura 1 u
- 4468/101 casaca + pestillo 2 u
- 4460/101 carril sup. 5,8 m
- 4463/022 cubilete 3 u
- 4464/022 tope suelo 2 u
- 4471/000 fijador vidrio/casaca 24 u
- 4474/000 cepillo 22 m
- 4470/001 tapas finales casaca 8 u
- 1833/109 tapajunta final 9 m
- 1834/109 tapajunta intermedio 12 m

**4483/001**  
max. 3460 mm  
3+1 puertas



- 4465/000 cojinete carril sup. 2 u
- 4466/000 giro sup. 2 u
- 4469/001 bisagra 4 u
- 4467/000 giro inf. 2 u
- 4473/022 bloqueo purtas 2 u
- 4472/034 llave montaje 1 u
- 4461/101 casaca 5 m
- 4462/101 casaca + cerradura 1 u
- 4468/101 casaca + pestillo 1 u
- 4460/101 carril sup. 3,5 m
- 4463/022 cubilete 2 u
- 4464/022 tope suelo 2 u
- 4471/000 fijador vidrio/casaca 16 u
- 4474/000 cepillo 14 m
- 4470/001 tapas finales casaca 8 u
- 1833/109 tapajunta final 9 m
- 1834/109 tapajunta intermedio 6 m

**4488/001**  
max. 5400 mm  
6 puertas



- 4465/000 cojinete carril sup. 5 u
- 4466/000 giro sup. 1 u
- 4469/001 bisagra 10 u
- 4467/000 giro inf. 1 u
- 4473/022 bloqueo puerta 1 u
- 4472/034 llave montaje 1 u
- 4461/101 casaca 8 m
- 4462/101 casaca + cerradura 1 u
- 4468/101 casaca + pestillo 2 u
- 4460/101 carril sup. 5,8 m
- 4463/022 cubilete 3 u
- 4464/022 tope suelo 1 u
- 4471/000 fijador vidrio/casaca 24 u
- 4474/000 cepillo 22 m
- 4470/001 tapas finales casaca 4 u
- 1833/109 tapajunta final 6 m
- 1834/109 tapajunta intermedio 15 m

**4484/001**  
max. 3460 mm  
4 puertas



- 4465/000 cojinete carril sup. 3 u
- 4466/000 giro sup. 1 u
- 4469/001 bisagra 6 u
- 4467/000 giro inf. 1 u
- 4473/022 bloqueo puerta 1 u
- 4472/034 llave montaje 1 u
- 4461/101 casaca 5 m
- 4462/101 casaca + cerradura 1 u
- 4468/101 casaca + pestillo 1 u
- 4460/101 carril sup. 3,2 m
- 4463/022 cubilete 2 u
- 4464/022 tope suelo 1 u
- 4471/000 fijador vidrio 16 u
- 4474/000 cepillo 14 m
- 4470/001 tapas finales 4 u
- 1833/109 tapajunta final 6 m
- 1834/109 tapajunta intermedio 9 m

**4489/001**  
max. 6380 mm  
6+1 puertas



- 4465/000 cojinete carril sup. 5 u
- 4466/000 giro sup. 2 u
- 4469/001 bisagra 10 u
- 4467/000 giro inf. 2 u
- 4473/022 bloqueo puerta 2 u
- 4472/034 llave montaje 1 u
- 4461/101 casaca 9 m
- 4462/101 casaca + cerradura 1 u
- 4468/101 casaca + pestillo 3 u
- 4460/101 carril sup. 6,4 m
- 4463/022 cubilete 4 u
- 4464/022 tope suelo 2 u
- 4471/000 fijador vidrio 28 u
- 4474/000 cepillo 26 m
- 4470/001 tapas finales 8 u
- 1833/109 tapajunta final 9 m
- 1834/109 tapajunta intermedio 15 m

# COTEK - PLEGABLE DESPLAZADA

PUERTAS PLEGABLES DESPLAZADA ACORDEÓN - SYSTÈME DE PORTE ACCORDÉON DÉSAJÉE  
OFF-AXIS FOLDING DOOR SYSTEM - PORTE A LIBRO FUORI ASSE

## PLEGABLE DESPLAZADA

ALUMINIO E INOX  
ALUMINIUM ET ACIER INOXYDABLE  
ALUMINIUM AND STAINLESS STEEL  
ALLUMINIO E ACCIAIO INOSSIDABILE

- espesor vidrio: 10-12 mm templado
- ancho maximo hoja: 960 mm
- alto maximo hoja recom.: 2600 mm
- peso max.: 80 kg/hoja
- se recomienda max. 6 hojas continuas
- precisa muescas en los vidrios.
- sin carril en el suelo
- sistema no estanco

- pods-limite porte: 80 kg
- large-limite porte: 960 mm
- Hauteur-limite porte: 2600 mm
- max. rec. 6 portes/kit
- verre 10-12 mm trempé
- encoches
- avec guide du sol
- no étanchéité
- weight max. door: 80 kg
- width max. door: 960 mm
- height max. door: 2600 mm
- max. rec. 6 doors/kit
- glass 10-12 mm tempered
- cut-out
- with floor guide
- not stagnancy
- peso max. porta: 80 kg
- larghezza max. porta: 960 mm
- altezza max. porta: 2600 mm
- max. rec. 6 porte/kit
- vetro 10-12 mm temperato
- tacca nel vetro
- con guida a terra
- non a tenuta stagna

## PRESUPUESTOS

1. escoger la configuración
2. indicar medida de hueco y alto.
3. indicar acabado (en stock plata mate)
4. enviar por e-mail ó fax la solicitud (si es posible con un croquis)

### ESTIMATIONS

1. choisir la configuration
2. indiquer la taille de l'ouverture et de la hauteur.
3. indiquer finition (stock: aluminium anod.naturel)
4. envoyer par e-mail ou par le fax le demande (si possible avec un croquis)

### QUOTATIONS

1. choose the configuration
2. indicate opening size and height.
3. indicate finish (aluminium natural anod. in stock)
4. send by e-mail or by fax the requirement (if possible with a sketch)

### PREVENTIVI

1. scegliere la configurazione
2. indicare le dimensioni di apertura e l'altezza.
3. indicare finitura (stock: alluminio anod.naturel)
4. inviare via e-mail o fax la richiesta (se possibile con uno schizzo)



Al L 5,8 m

GUÍA SUPERIOR  
COULISSE HAUTE  
UPPER TRACK  
GUIDA SUPERIOR  
4460/101



inox s.s. Al plus 80 kg/u

COJINETE SUPERIOR  
GALET SUPERIEUR  
UPPER ROLLER  
PATTINO SCORREVOLE SUPERIORE  
4465/000



inox s.s. Al 80 kg/u

GIRO SUPERIOR PIVOTANTE  
PIVOT SUPERIEUR  
UPPER PIVOTING HINGE  
CERNIERA PIVOTANTE SUPERIORE  
4466/000



inox s.s. Al 80 kg/u

GIRO INFERIOR PIVOTANTE  
PIVOT INFÉRIEUR  
BOTTOM PIVOTING HINGE  
CERNIERA PIVOTANTE INFERIORE  
4467/000



Al L 3 m

CASACA VIDRIO  
PROFIL VERRE  
PROFILE GLASS  
PROFILO VETRO  
4461/101



Al L 1,2 m

CASACA VIDRIO X CERRADURA  
PROFIL VERRE X SERRURE  
PROFILE GLASS X LOCK  
PROFILO VETRO X SERRATURA  
4462/001



inox s.s. Al Zn

CERRADURA DISTINTA LLAVE  
SERRURE COMBINAISONS DIFFÉRENTES  
LOCK DIFFERENT KEYED  
SERRATURA COMBINAZIONI DISTINTE  
4462/L01



MISMA LLAVE: CONSULTAR  
MÊME COMBINAISON: CONSULTE  
KEYD ALIKE: CONSULT  
STESSA COMBINAZIONE: CONSULTARE



Al L 1,2 m

CASACA VIDRIO X PESTILLO LATERAL  
PROFIL VERRE X VERROULATÉRALE  
PROFILE GLASS X LATERAL BOLT  
PROFILO VETRO X CHIAVISTELLO LATERALE  
4468/001



inox s.s. Al Zn

PESTILLO LATERAL  
VERROULATÉRALE  
LATERAL BOLT  
CHIAVISTELLO LATERALE  
4468/B01



inox s.s.

CUBILETE  
GÂUCHE  
STRIKE PATCH  
CONTROSERRATURA  
4463/022



inox s.s. plus Ø 25

ANCLAJE VIDRIO-CASACA 4461  
CONNEXION VERRE-PERFIL 4461  
CONNESSIONE GLASS-PROFIL 4461  
CONNESSIONE VETRO-PROFILO 4461  
4471/000



inox s.s. Al

BISAGRA X 4461  
CHARNIÈRE X 4461  
HINGE X 4461  
CERNIERA X 4461  
4469/001



inox s.s. Al

TAPA FINAL CASACA  
EMBOUT X 4461  
END-CAP X 4461  
COPRITESTA X 4461  
4470/001



inox s.s. plus

CEPILLO  
BROSSER  
BRUSH  
SPAZZOLA  
4474/200 12 mm



Al plus

TOPE SUELO  
ARRETEZ DE PORTE DU SOL  
DOOR STOPPER  
STOP SUOLO  
4464/022



inox s.s. plus

RETENCIÓN PUERTAS SUELO  
RÉTENTION PORTES  
DOORS RETENTION  
RITENZIONE PORTE  
4473/022



TORNILLOS  
VIS  
SCREWS  
VITI  
4477/000



LLAVE  
OUTIL  
TOOL x SCREWS  
UTENSILE REGOLABILE x VITI  
4472/034



# COTEK - PLEGABLE DESPLAZADA

PUERTAS PLEGABLES DESPLAZADA ACORDEÓN - SYSTÈME DE PORTE ACCORDÉON DÉSAJÉE  
OFF-AXIS FOLDING DOOR SYSTEM - PORTE A LIBRO FUORI ASSE

## CARRIL INFERIOR

Las puertas de la Plegable Desplazada necesitan el carril 4478 empotrado en el suelo y un cojinete inferior 4479 cada 2 hojas.

Les portes du Plegable Desplazada besoin du guidage inférieure 4478 incorporé dans le sol et un rouleau inférieure 4479 chaque deux portes.

The Plegable Desplazada's doors need the bottom guide 4478 embedded in the floor and one bottom roller 4479 every 2 doors.

Le porte della Plegable Desplazada richiedono la guida inferiore 4478 incassata nel suolo e un cuscinetto 4479 ogni 2 porte.



Al 5,8 m 28x20

GUÍA INFERIOR EMPOTRABLE  
COULISSE INFÉRIEUR D'ENCASTREMENT  
BOTTOM TRACK RECESSED  
GUIDA INFERIORE INCASSO  
**4478/101**



inox s.s. Al plus

COJINETE INFERIOR  
GALET INFÉRIEUR  
BOTTOM ROLLER  
PATTINO SCORREVOLE INFERIORE  
**4479/000**

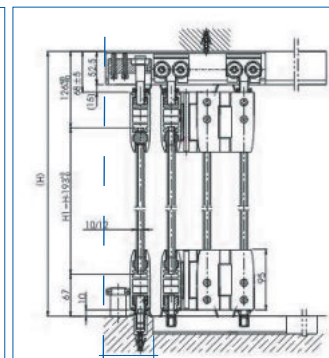
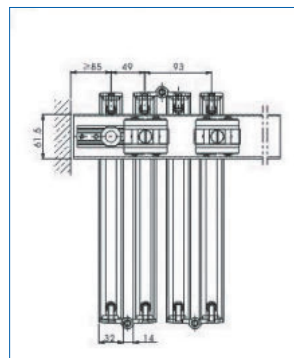

90

MODELO	4480/D01	4481/D01	4484/D01	4485/D01	4488/D01	4489/D01
HOJAS	2	2+1	4	4+1	6	6+1
	1800	2700	3600	4500	5400	6300
	HUECO					

Se recomienda dejar una separación de 90 mm para colocar el giro inferior 4467 de la primera puerta  
Nous recommandons de laisser un espace de 90 mm pour positionner le pivot inférieur 4467 de la première porte  
We recommend leaving a gap of 90 mm to position the lower pivot 4467 of the first door  
Si raccomandanda lasciare uno spazio di 90 mm per collocare la cerniera inferiore della prima porta

4480/D01  
max. 1800 mm  
2 puertas



- 4465/000 cojinete carril sup. 1 u
- 4479/000 cojinete carril inf. 1 u
- 4466/000 giro sup. 1 u
- 4469/001 bisagra 2 u
- 4467/000 giro inf. 1 u
- 4473/022 bloqueo puerta 1 u
- 4472/034 llave montaje 1 u
- 4461/101 casaca 3 m
- 4462/101 casaca + cerradura 1 u
- 4460/101 carril sup. 2 m
- 4478/101 carril inf. 1 m
- 4463/022 cubilete 1 u
- 4464/022 tope suelo 1 u
- 4471/000 fijador vidrio/casaca 8 u
- 4474/000 cepillo 8 m
- 4470/001 tapas finales casaca 4 u
- 4477/000 tacos y tornillos 4 u
- 1833/109 tapajunta final 6 m
- 1834/109 tapajunta intermedio 3 m

4485/D01  
max. 4500 mm  
4+1 puertas

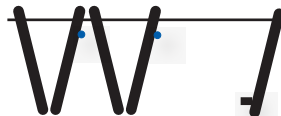

- 4465/000 cojinete carril sup. 2 u
- 4479/000 cojinete carril inf. 2 u
- 4466/000 giro sup. 2 u
- 4469/001 bisagra 2 u
- 4467/000 giro inf. 2 u
- 4473/022 bloqueo puerta 2 u
- 4472/034 llave montaje 1 u
- 4461/101 casaca 7 m
- 4462/101 casaca + cerradura 1 u
- 4468/101 casaca + pestillo 2 u
- 4460/101 carril sup. 5 m
- 4478/101 carril inf. 4 m
- 4463/022 cubilete 3 u
- 4464/022 tope suelo 2 u
- 4471/000 fijador vidrio/casaca 20 u
- 4474/000 cepillo 20 m
- 4470/001 tapas finales casaca 8 u
- 4477/000 tacos y tornillos 20 u
- 1833/109 tapajunta final 9 m
- 1834/109 tapajunta intermedio 9 m

4481/D01  
max. 2700 mm  
2+1 puertas



- 4465/000 cojinete carril sup. 1 u
- 4479/000 cojinete carril inf. 1 u
- 4466/000 giro sup. 2 u
- 4469/001 bisagra 2 u
- 4467/000 giro inf. 2 u
- 4473/022 bloqueo puerta 2 u
- 4472/034 llave montaje 1 u
- 4461/101 casaca 4 m
- 4462/101 casaca + cerradura 1 u
- 4468/101 casaca + pestillo 1 u
- 4460/101 carril sup. 3 m
- 4478/101 carril inf. 1 m
- 4463/022 cubilete 2 u
- 4464/022 tope suelo 2 u
- 4471/000 fijador vidrio/casaca 12 u
- 4474/000 cepillo 12 m
- 4470/001 tapas finales casaca 8 u
- 4477/000 tacos y tornillos 8 u
- 1833/109 tapajunta final 9 m
- 1834/109 tapajunta intermedio 3 m

4488/D01  
max. 5400 mm  
6 puertas



- 4465/000 cojinete carril sup. 3 u
- 4479/000 cojinete carril inf. 3 u
- 4466/000 giro sup. 1 u
- 4469/001 bisagra 10 u
- 4467/000 giro inf. 1 u
- 4473/022 bloqueo puerta 1 u
- 4472/034 llave montaje 1 u
- 4461/101 casaca 9 m
- 4462/101 casaca + cerradura 1 u
- 4468/101 casaca + pestillo 2 u
- 4460/101 carril sup. 5,8 m
- 4478/101 carril inf. 5,8 m
- 4463/022 cubilete 3 u
- 4464/022 tope suelo 1 u
- 4471/000 fijador vidrio/casaca 24 u
- 4474/000 cepillo 24 m
- 4470/001 tapas finales casaca 4 u
- 4477/000 tacos y tornillos 24 u
- 1833/109 tapajunta final 6 m
- 1834/109 tapajunta intermedio 15 m

4484/D01  
max. 3600 mm  
4 puertas



- 4465/000 cojinete carril sup. 2 u
- 4479/000 cojinete carril inf. 2 u
- 4466/000 giro sup. 1 u
- 4469/001 bisagra 4 u
- 4467/000 giro inf. 1 u
- 4473/022 bloqueo puerta 1 u
- 4472/034 llave montaje 1 u
- 4461/101 casaca 6 m
- 4462/101 casaca + cerradura 1 u
- 4468/101 casaca + pestillo 1 u
- 4460/101 carril sup. 4 m
- 4478/101 carril inf. 3 m
- 4463/022 cubilete 2 u
- 4464/022 tope suelo 1 u
- 4471/000 fijador vidrio/casaca 8 u
- 4474/000 cepillo 16 m
- 4470/001 tapas finales casaca 4 u
- 4477/000 tacos y tornillos 16 u
- 1833/109 tapajunta final 6 m
- 1834/109 tapajunta intermedio 9 m

4489/D01  
max. 6400 mm  
6+1 puertas



- 4465/000 cojinete carril sup. 3 u
- 4479/000 cojinete carril inf. 3 u
- 4466/000 giro sup. 2 u
- 4469/001 bisagra 2 u
- 4467/000 giro inf. 2 u
- 4473/022 bloqueo puerta 2 u
- 4472/034 llave montaje 1 u
- 4461/101 casaca 10 m
- 4462/101 casaca + cerradura 1 u
- 4468/101 casaca + pestillo 3 u
- 4460/101 carril sup. 6,5 m
- 4478/101 carril inf. 5,8 m
- 4463/022 cubilete 4 u
- 4464/022 tope suelo 2 u
- 4471/000 fijador vidrio/casaca 20 u
- 4474/000 cepillo 26 m
- 4470/001 tapas finales casaca 8 u
- 4477/000 tacos y tornillos 30 u
- 1833/109 tapajunta final 9 m
- 1834/109 tapajunta intermedio 15 m



## COTEK - KOBE 80 KG

PUERTAS CORREDERA CON AMORTIGUADOR - PORTES COULISSANTS AVEC AMORTISSEURS  
SLIDING DOORS WITH DUMPERS - PORTE SCORREVOLI CON AMORTIZZATORI

PLATA MATE  
ALU. MAT  
ALU. NATURELLE  
01

## COTEK - KOBE 80 KG

PUERTAS CORREDERA CON AMORTIGUADOR - PORTES COULISSANTS AVEC AMORTISSEURS  
SLIDING DOORS WITH DUMPERS - PORTE SCORREVOLI CON AMORTIZZATORI

PLATA MATE  
ALU. MAT  
ALU. NATURELLE  
01

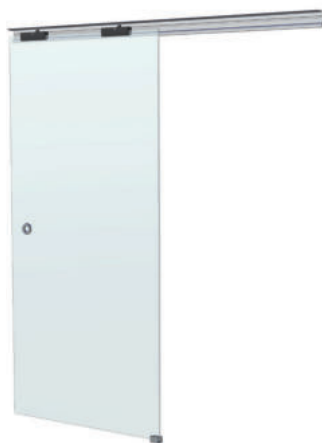

### MONTAJE EMPOTRADO

KIT PORTE COULISSANTE ENCASTRÉ AU PLAFOND  
KIT SLIDING DOOR RECESSED IN THE CEILING KIT PORTA  
SCORREVOLE INCASSATA NEL SOFFITTO

<b>3450/E21</b>	1,93 m	○	€/U
<b>3450/E31</b>	2,90 m	○	
CON AMORTIGUADOR, AVEC AMORTISSEURS, WITH DUMPERS, CON AMORTIZZATORI			
3445/201 - 3445/301	1 u. carril		
3440/001	2 u. pinzas + amortiguador		
4965/001	1 u. "U" guía inferior		
4966/001	1 u. stop suelo		
4207/001	1 u. uñero		



### MONTAJE EMPOTRADO A TECHO + VIDRIO FIJO

KIT PORTE COULISSANTE ENCASTRÉ AU PLAFOND + VERRE FIXE  
KIT SLIDING DOOR RECESSED IN THE CEILING + FIXED GLASS  
KIT PORTA SCORREVOLE INCASSATA NEL SOFFITTO + VETRO FISSO

<b>3452/E21</b>	1,93 m	○	€/U
<b>3452/E31</b>	2,90 m	○	
CON AMORTIGUADOR, AVEC AMORTISSEURS, WITH DUMPERS, CON AMORTIZZATORI			
3445/201 - 3445/301	1 u. carril		
4963/101 - 4963/201	1 u. perfil inf. vidrio fijo		
3440/001	2 u. pinzas + amortiguador		
4965/001	1 u. "U" guía inferior		
4966/001	1 u. stop suelo		
4207/001	1 u. uñero		

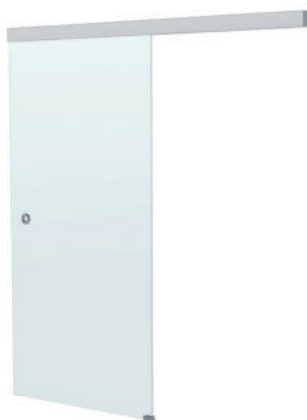

### MONTAJE A PARED

KIT DE PORTE COULISSANTE FIXÉE AU MUR  
KIT SLIDING DOOR FIXED TO THE WALL  
KIT PORTA SCORREVOLE FISSATA APARETE

<b>3450/P21</b>	1,93 m	○	€/U
<b>3450/P31</b>	2,90 m	○	
CON AMORTIGUADOR, AVEC AMORTISSEURS, WITH DUMPERS, CON AMORTIZZATORI			
3445/201 - 3445/301	1 u. carril		
3447/201 - 3447/301	1 u. tapa carril		
3440/001	2 u. pinzas		
4965/001	1 u. "U" guía inferior		
4966/001	1 u. stop suelo		
3444/001	2 u. tapa lateral		
4207/001	1 u. uñero		



### MONTAJE A TECHO + VIDRIO FIJO

KIT PORTE COULISSANTE FIXÉE AU PLAFOND + VERRE FIXE  
KIT SLIDING DOOR FIXED TO THE CEILING + FIXED GLASS  
KIT PORTA SCORREVOLE A SOFFITTO + VETRO FISSO

<b>3452/T21</b>	1,93 m	○	€/U
<b>3452/T31</b>	2,90 m	○	
CON AMORTIGUADOR, AVEC AMORTISSEURS, WITH DUMPERS, CON AMORTIZZATORI			
3445/201 - 3445/301	1 u. carril		
3447/201 - 3447/301	1 u. tapa carril		
4963/101 - 4963/201	1 u. perfil inf. vidrio fijo		
3440/001	2 u. pinzas		
4965/001	1 u. "U" guía inferior		
4966/001	1 u. stop suelo		
4207/001	1 u. uñero		



### MONTAJE A VIDRIO FIJO

KIT DE PORTE COULISSANTE FIXÉE AU MUR DE VERRE  
KIT SLIDING DOOR FIXED TO THE GLASS WALL  
KIT PORTA SCORREVOLE FISSATA A PARETE DI VETRO

<b>3450/V21</b>	1,93 m	○	€/U
<b>3450/V31</b>	2,90 m	○	
CON AMORTIGUADOR, AVEC AMORTISSEURS, WITH DUMPERS, CON AMORTIZZATORI			
3445/201 - 3445/301	1 u. carril		
3447/201 - 3447/301	1 u. tapa carril		
4961/201 - 4961/301	3 m. perfil anclaje vidrio fijo		
3440/001	2 u. pinzas		
4965/001	1 u. "U" guía inferior		
4966/001	1 u. stop suelo		
3444/001	2 u. tapa lateral carril		
4207/001	1 u. uñero		

**AUTOPORTANTE  
TAMBIÉN PARA DUCHAS  
VER PÁG. C-31**

### MONTAJE A PARED LATERAL + VIDRIO FIJO

KIT PORTE COULISSANTE FIXÉE AU PLAFOND + VERRE FIXE  
KIT SLIDING DOOR FIXED TO THE CEILING + FIXED GLASS  
KIT PORTA SCORREVOLE A SOFFITTO + VETRO FISSO

<b>3453/L21</b>	1,93 m	○	€/U
<b>3453/L31</b>	2,90 m	○	
CON AMORTIGUADOR, AVEC AMORTISSEURS, WITH DUMPERS, CON AMORTIZZATORI			
3445/201 - 3445/301	1 u. carril		
3447/201 - 3447/301	1 u. tapa carril		
4963/101 - 4963/201	1 u. perfil inf. vidrio fijo		
3440/001	2 u. pinzas		
4965/001	1 u. "U" guía inferior		
4966/001	1 u. stop suelo		
4207/001	1 u. uñero		
<b>3454/001</b>	2 u. anclaje carril-pared		

# COTEK - KYOTO 120 KG

PUERTAS CORREDERA - PORTES COULISSANTS  
SLIDING DOORS - PORTE SCORREVOLI

## KYOTO

- peso max. puerta: 120 kg/puerta
- vidrio 10-12 mm
- sin muesca en el vidrio

- pods-limite porte: 120 kg/porte
- verre 10-12 mm
- sans encoches
- weight max. door: 120 kg/door
- glass 10-12 mm
- without cut-out
- peso max. porta: 120 kg/porta
- vetro 10-12 mm
- senza tacca nel vetro

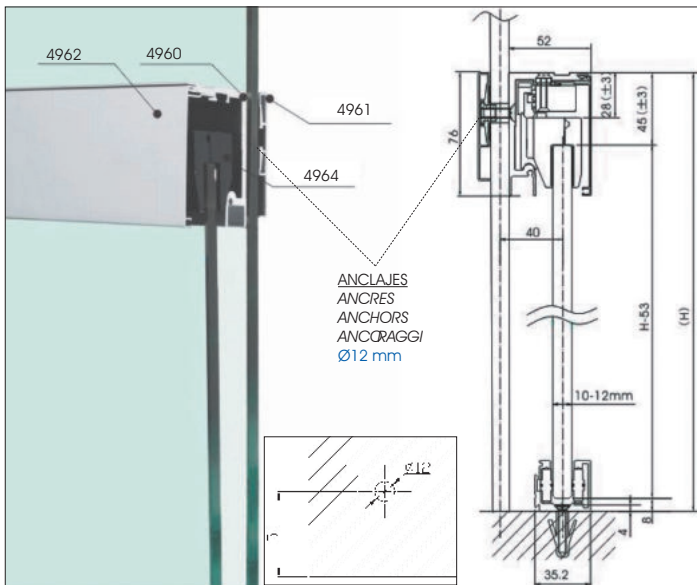
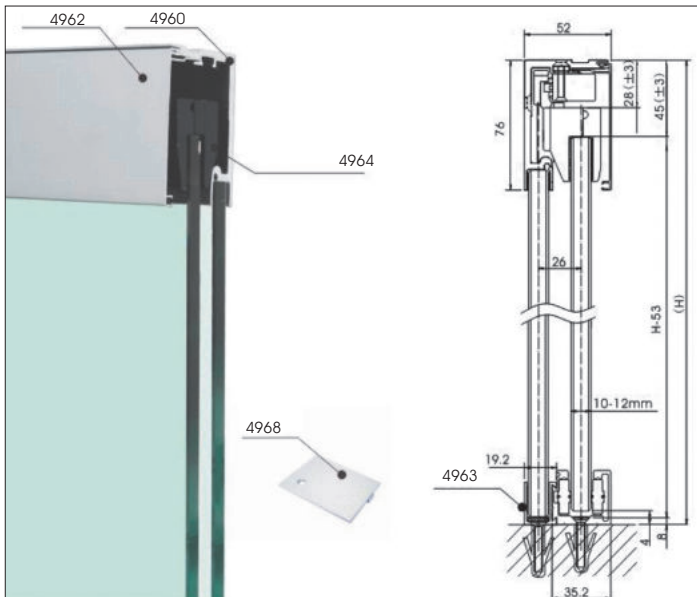
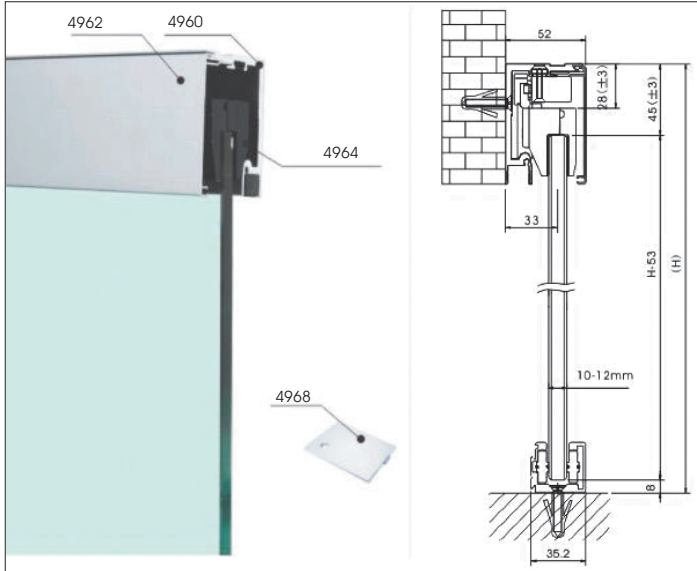

CARRIL  
COULISSE HAUTE  
UPPER TRACK  
GUIDA SUPERIORE  
4960/201 1,93 m  
4960/301 2,90 m  
4960/501 5,80 m

PERFIL TAPA CARRIL  
PROFIL COUVERTURE COULISSE  
TRACK COVER PROFIL  
PROFILO COPERTINA GUIDA  
4962/201 1,93 m  
4962/301 2,90 m  
4962/501 5,80 m

PERFIL INFERIOR VIDRIO FIJO  
PROFIL INFERIEUR VERRE FIXE  
BOTTOM PROFILE FIXED GLASS  
PROFILO INFERIORE VETRO FISSO  
Se acopla a 4964 y 4965  
4963/101 0,96 m  
4963/201 1,45 m  
4963/301 2,90 m

PERFIL SOPORTE A PARED  
DE VIDRIO + 9 ANCLAJES  
PROFIL SUPPORT MUR DE  
VERRE + 9 ANCHRES  
PROFILE WALL-GLASS SUPPORT  
+ 9 ANCHORS  
PROFILO SUPPORTO A PARETE  
DI VETRO + 9 ANCORAGGI  
4961/201 1,93 m  
4961/301 2,90 m  
4961/501 5,80 m

KIT PINZAS PORTAVIDRIO  
KIT PINCE POUR VERRE  
CLAMP FOR GLASS KIT  
KIT PINZA PER VETRO

4964/011  
CON AMORTIGUADORES  
AVEC AMORTISSEURS  
WITH DUMPERS  
CON AMORTIZZATORI  
Pinzas 2 u.  
Guía Inferior 1 u.  
Stop Suelo 1 u.

4970/011  
SIN AMORTIGUADOR  
SANS AMORTISSEURS  
WITHOUT DUMPERS  
SENZA AMORTIZZATORI  
Pinzas 2 u.  
Guía Inferior 1 u.  
Stop Suelo 1 u.

REMATE FINAL CARRIL- GRIS  
BOUCHON COULISSE- GRIS  
END-CAP TRACK-GRAY  
COPRITESTA TUBO - GRIGIO .  
4968/009

REMATE FINAL CARRIL- GRIS  
BOUCHON COULISSE- GRIS  
END-CAP TRACK-GRAY  
COPRITESTA TUBO - GRIGIO .  
4969/009

UNERO DOBLE ADHESIVO  
POIGNEE DOUBLE ADHESIVE  
DOUBLE ADHESIVE PULL  
POMO DOPPIO ADHESIVO  
4207/0..  
4207/0..

GALGA MONTAJE UNEROS  
GABARIT DE MONTAGE  
INSTALLATION TOOL  
SAGOMA AIUTO MONTAGGIO  
4209/000

POMO  
POIGNEE  
KNOB  
POMO  
4223/0..

CR. BRILLO	PL. M	BRUTO	PLÁSTICO
CHR. POLI	ALU. M	BRUT	PLASTOU E
CR. LUC	ALU. M	RAW	PLASTIC
	ALL. NAT	GREZZO	PLASTICA
32	01	00	09
Al	5,8m	50x76	€/u
10-12 mm			
			o
			o
			o
Al	5,8m	74x24	€/u
			o
			o
			o
Al	5,8m	26x19,2	€/u
10-12 mm		∞ 4964-4965	
			o
			o
			o
Al	5,8m	70x7	€/u
∅ 12 mm			
			o
			o
			o
Al	120kg/2u.	180x43	€/u
10-12 mm			
			o
			o
			o
plas	52x76	∞ 4960 - 4962	€/u
			o
plas	52x76	∞ 4960 - 4962	€/u
			o
			o
	∅ 60		€/u
			o
			o
Al			€/u
inox s.s.			
			o
			o
Al	100		€/u
8-10 mm			
			o
			o

## COTEK - KYOTO 120KG

PUERTAS CORREDERA CON AMORTIGUADOR - PORTES COULISSANTS AVEC AMORTISSEURS  
SLIDING DOORS WITH DUMPERS - PORTE SCORREVOLI CON AMORTIZZATORI

PLATA MATE  
ALU. MAT  
ALU. MATT  
ALL. NATURALE  
01

## COTEK - KYOTO 120KG

PUERTAS CORREDERA CON AMORTIGUADOR - PORTES COULISSANTS AVEC AMORTISSEURS  
SLIDING DOORS WITH DUMPERS - PORTE SCORREVOLI CON AMORTIZZATORI

PLATA MATE  
ALU. MAT  
ALU. MATT  
ALL. NATURALE  
01

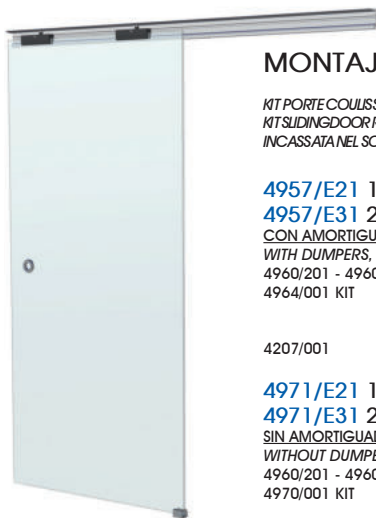

### MONTAJE EMPOTRADO

KIT PORTE COULISSANTE ENCASTRÉ AU PLAFOND  
KIT SLIDING DOOR RECESSED IN THE CEILING  
KIT PORTA SCORREVOLE INCASSATA NEL SOFFITTO

4957/E21 1,93 m  € / U  
4957/E31 2,90 m  € / U  
CON AMORTIGUADOR, AVEC AMORTISSEURS,  
WITH DUMPERS, CON AMORTIZZATORI  
4960/201 - 4960/301 1 u. carril  
4964/001 KIT 2 u. pinza + amortiguador  
1 u. "U" guía inferior  
1 u. stop suelo  
4207/001 1 u. uñero

4971/E21 1,93 m  € / U  
4971/E31 2,90 m  € / U  
SIN AMORTIGUADOR, SANS AMORTISSEURS,  
WITHOUT DUMPERS, SENZA AMORTIZZATORI  
4960/201 - 4960/301 1 u. carril  
4970/001 KIT 2 u. pinzas  
1 u. "U" guía inferior  
1 u. stop suelo  
4207/001 1 u. uñero



### MONTAJE EMPOTRADO A TECHO + VIDRIO FIJO

KIT PORTE COULISSANTE ENCASTRÉ AU PLAFOND + VERRE FIXE  
KIT SLIDING DOOR RECESSED IN THE CEILING + FIXED GLASS  
KIT PORTA SCORREVOLE INCASSATA NEL SOFFITTO + VETRO FISSO

4958/E21 1,93 m  € / U  
4958/E31 2,90 m  € / U  
CON AMORTIGUADOR, AVEC AMORTISSEURS,  
WITH DUMPERS, CON AMORTIZZATORI  
4960/201 - 4960/301 1 u. carril  
4963/101 - 4963/201 1 u. perfil inf. vidrio fijo  
4964/101 KIT 2 u. pinzas + amortiguador  
1 u. "U" guía inferior  
1 u. stop suelo  
4207/001 1 u. uñero

4972/E21 1,93 m  € / U  
4972/E31 2,90 m  € / U  
SIN AMORTIGUADOR, SANS AMORTISSEURS,  
WITHOUT DUMPERS, SENZA AMORTIZZATORI  
4960/201 - 4960/301 1 u. carril  
4963/101 - 4963/201 1 u. perfil inf. vidrio fijo  
4970/001 KIT 2 u. pinzas  
1 u. "U" guía inferior  
1 u. stop suelo  
4207/001 1 u. uñero



### MONTAJE A PARED

KIT DE PORTE COULISSANTE FIXÉE AU MUR  
KIT SLIDING DOOR FIXED TO THE WALL  
KIT PORTA SCORREVOLE FISSATA A PARETE

4957/P21 1,93 m  € / U  
4957/P31 2,90 m  € / U  
CON AMORTIGUADOR, AVEC AMORTISSEURS,  
WITH DUMPERS, CON AMORTIZZATORI  
4960/201 - 4960/301 1 u. carril  
4962/201 - 4262/301 1 u. tapa carril  
4964/001 KIT 2 u. pinzas + amortiguador  
1 u. "U" guía inferior  
1 u. stop suelo  
4968/009 2 u. tapa lateral  
4207/001 1 u. uñero

4971/P21 1,93 m  € / U  
4971/P31 2,90 m  € / U  
SIN AMORTIGUADOR, SANS AMORTISSEURS,  
WITHOUT DUMPERS, SENZA AMORTIZZATORI  
4960/201 - 4960/301 1 u. carril  
4962/101 3 m. tapa carril 3 m  
4970/001 KIT 2 u. pinzas  
1 u. "U" guía inferior  
1 u. stop suelo  
4968/009 2 u. tapa lateral  
4207/001 1 u. uñero



### MONTAJE A TECHO + VIDRIO FIJO

KIT PORTE COULISSANTE FIXÉE AU PLAFOND + VERRE FIXE  
KIT SLIDING DOOR FIXED TO THE CEILING + FIXED GLASS  
KIT PORTA SCORREVOLE A SOFFITTO + VETRO FISSO

4958/T21 1,93 m  € / U  
4958/T31 2,90 m  € / U  
CON AMORTIGUADOR, AVEC AMORTISSEURS,  
WITH DUMPERS, CON AMORTIZZATORI  
4960/201 - 4960/301 1 u. carril  
4962/201 - 4262/301 1 u. tapa carril  
4963/101 - 4263/201 1 u. perfil inf. vidrio fijo  
4964/001 KIT 2 u. pinzas + amortiguador  
1 u. "U" guía inferior  
1 u. stop suelo  
4207/001 1 u. uñero

4972/T21 1,93 m  € / U  
4972/T31 2,90 m  € / U  
SIN AMORTIGUADOR, SANS AMORTISSEURS,  
WITHOUT DUMPERS, SENZA AMORTIZZATORI  
4960/201 - 4960/301 1 u. carril  
4962/201 - 4262/301 1 u. tapa carril  
4963/101 - 4263/201 1 u. perfil inf. vidrio fijo  
4970/001 KIT 2 u. pinzas  
1 u. "U" guía inferior  
1 u. stop suelo  
4207/001 1 u. uñero



### MONTAJE A VIDRIO FIJO

KIT DE PORTE COULISSANTE FIXÉE AU MUR DE VERRE  
KIT SLIDING DOOR FIXED TO THE GLASS WALL  
KIT PORTA SCORREVOLE FISSATA A PARETE DI VETRO

4959/V21 1,93 m  € / U  
4959/V31 2,90 m  € / U  
CON AMORTIGUADOR, AVEC AMORTISSEURS,  
WITH DUMPERS, CON AMORTIZZATORI  
4960/201 - 4960/301 1 u. carril  
4962/201 - 4262/301 1 u. tapa carril  
4961/201 - 4961/301 1 u. perfil anclaje vidrio fijo  
4964/001 KIT 2 u. pinzas + amortiguador  
1 u. "U" guía inferior  
1 u. stop suelo  
4968/009 2 u. tapa lateral carril  
4207/001 1 u. uñero

4973/V21 1,93 m  € / U  
4973/V31 2,90 m  € / U  
SIN AMORTIGUADOR, SANS AMORTISSEURS,  
WITHOUT DUMPERS, SENZA AMORTIZZATORI  
4960/201 - 4960/301 1 u. carril  
4962/201 - 4262/301 1 u. tapa carril  
4961/201 - 4961/301 1 u. perfil anclaje vidrio fijo  
4970/001 KIT 2 u. pinzas  
1 u. "U" guía inferior  
1 u. stop suelo  
4968/009 2 u. tapa lateral carril  
4207/001 1 u. uñero



# COTEK - CANTON 80KG

PUERTAS CORREDERA - PORTES COULISSANTS  
SLIDING DOORS - PORTE SCORREVOLI

## CANTON

- peso max. puerta: 80 kg/puerta
- vidrio 8-10 mm
- ancho min. vidrio 600 mm
- sin muesca en el vidrio
- con amortiguador y autocierre

- pods-limite porte: 80 kg/porte
- verre 8-10 mm
- largeur minimale verre 600 mm
- sans encoches
- avec amortisseur et fermeture automatique
- weight max. door: 80 kg/door
- glass 8-10 mm
- min. wide glass 600 mm
- without cut-out
- buffer and sel-closing system
- peso max. porta: 80 kg/porta
- vetro 8-10 mm
- larghezza min. vetro 600 mm
- senza tacca nel vetro
- ammortizzatore e autochiusura

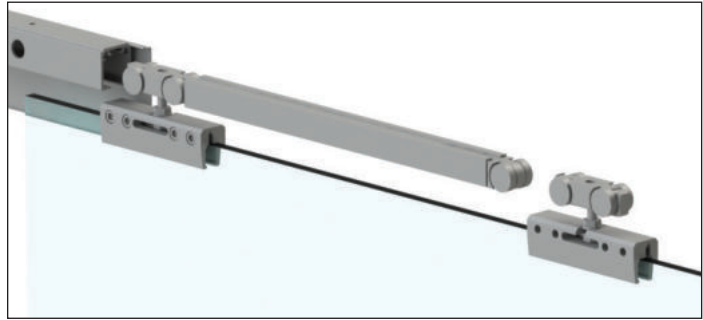

### SECCIÓN PARA PUERTAS DE VIDRIO

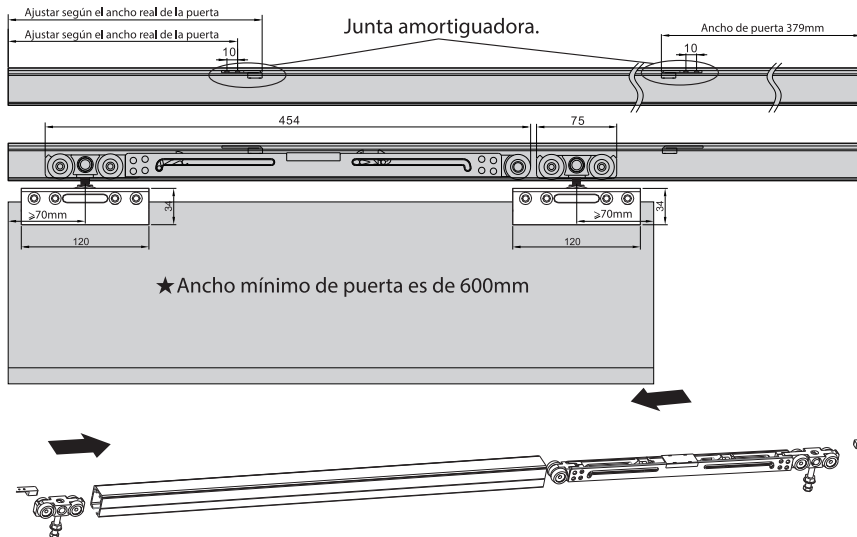
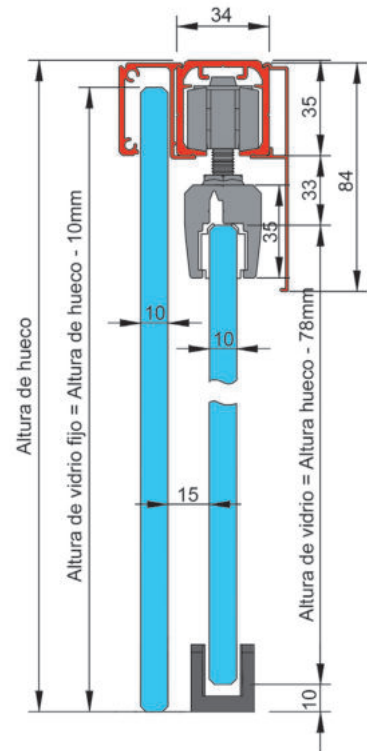

### MONTAJE A TECHO O PARED EL CARRIL 5111 ESTÁ MECANIZADO CON UN TALADRO CADA 25 CM PARA SER FIJADO DIRECTAMENTE A LA PARED SIN NECESIDAD DE ESCUADRAS

- Montage au plafond ou au muret. Le profilé supérieur 5111 est usiné avec des trous tous les 25 cm pour être fixé directement au mur sans avoir besoin de supports.
- Ceiling or wall mount. the track 5111 is machined with holes every 25 cm to be fixed directly to the wall without the need for brackets
- Montaggio a soffitto o a muro. La guida superiore 5111 è meccanizzata con fori ogni 25 cm per essere fissata alla parete senza necessità di supporti

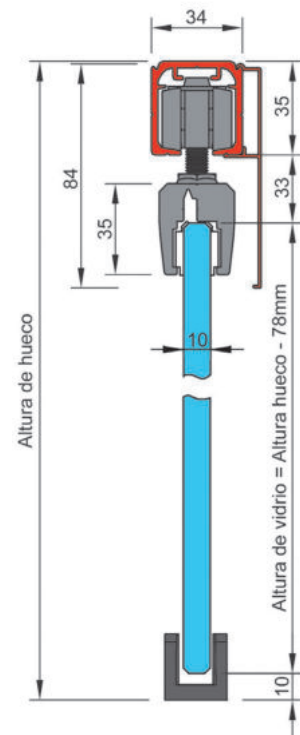
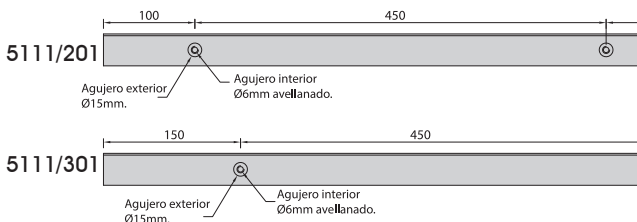



# COTEK - CANTÓN 80 KG

PUERTAS CORREDERA - PORTES COULISSANTS  
SLIDING DOORS - PORTE SCORREVOLI

CR. BRILLO	PL. M.	BRUTO	PLÁSTICO
CHR. POLI	ALU. M.	BRUT	PLASTIQU E
CR. LUC	ALL. NAT	RAW	PLASTIC
		GREZZO	PLASTICA
32	01	00	09

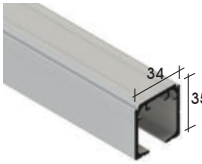

**CARRIL**  
PROFIL SUPÉRIEUR  
UPPER TRACK  
GUIDA SUPERIORE  
5111/201 2 m  
5111/301 3 m

Al		2/3 m		€/u
----	--	-------	--	-----



**PERFIL CARRIL FIJO**  
PROFIL FIXE  
FIXED RAIL PROFILE  
PROFLO BINARIO FISSO  
5114/201 2 m  
5114/301 3 m

Al		2/3 m	∞ 5111	€/u
----	--	-------	--------	-----

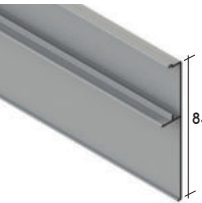

**PERFIL TAPA CARRIL**  
PROFIL COUVERTURE  
TRACK COVER PROFIL  
PROFLO COPERTINA GUIDA  
5112/201 2 m  
5112/301 3 m

Al		2/3 m	∞ 5111	€/u
----	--	-------	--------	-----

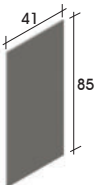

**TAPA LATERAL DE CARRIL**  
COUVERTURE LATÉRALE DU PROFIL  
TOP RAIL SIDE COVER  
COPERTURA LATERALE SUPERIORE  
5113/001

Al			∞ 5112	€/u
----	--	--	--------	-----



**KIT PINZA PORTAVIDRIO**  
KIT PINCE POUR VERRE  
KIT CLAMP FOR GLASS  
KIT PINZA PER VETRO  
5110/001 CON BUFFER

Al	Fe		8-10 mm	€/u
				80 kg/set

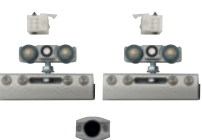

**COJINETES PARA 1 PUERTA**  
ROULEMENTS POUR 1 PORTE  
FITTINGS FOR 1 DOOR  
CUSCINETTI PER 1 ANTE  
5125/000 SIN BUFFER

Al	Fe		8-10 mm	€/u
				80 kg/set



**UÑERO DOBLE ADHESIVO**  
POIGNEÉ DOUBLE ADHESIVE  
DOUBLE ADHESIVE PULL  
POMO DOPPIO ADHESIVO  
4207/0..  
4207/0..

	∅ 60			€/u
--	------	--	--	-----

			NEGRO NOIR BLACK NERO	ON
--	--	--	--------------------------------	----

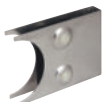

**GALGA MONTAJE UÑEROS**  
GABARIT DE MONTAGE  
INSTALLATION TOOL  
SAGOMA AIUTO MONTAGGIO  
4209/000

Al				€/u
----	--	--	--	-----



**POMO**  
POIGNEÉ  
KNOB  
POMO  
4223/0..

Al	100		8-10 mm	€/u
----	-----	--	---------	-----

# COTEK - CANTÓN 80 KG

PUERTAS CORREDERA - PORTES COULISSANTS  
SLIDING DOORS - PORTE SCORREVOLI

PLATA MATE ALU. MAT ALL. NATURALE	01
---	----

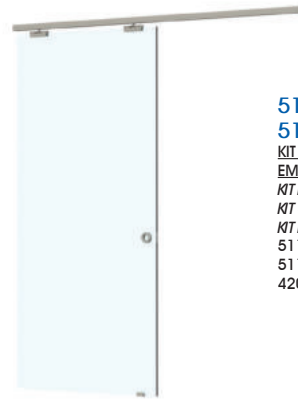

5118/E21 2 m  
5118/E31 3 m  
KIT PUERTA CORREDERA PARA CRISTAL  
EMPOTRABLE EN EL TECHO  
KIT PORTE COULISSANTE VERRE AU PLAFOND  
KIT SLIDINGDOOR RECESSED IN THE CEILING  
KIT PORTA SCORREVOLE INCASSATA NEL SOFFITTO  
5111/201-5111/301 1 u. carril  
5110/001 1 u. set pinzas portavidrio  
4207/001 1 u. uñero

Incluye guiador de suelo

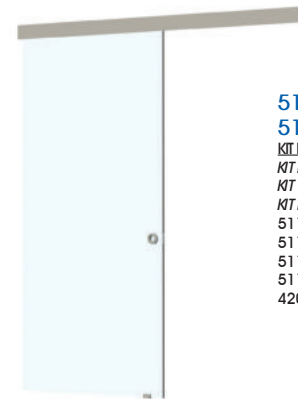

5119/P21 2 m  
5119/P31 3 m  
KIT PUERTA CORREDERA DE CRISTAL A PARED  
KIT DE PORTE COULISSANTE FIXÉE AU MUR  
KIT SLIDINGDOOR FIXED TO THE WALL  
KIT PORTA SCORREVOLE FISSATA A PARETE  
5111/201-5111/301 1 u. carril  
5112/201-5112/301 1 u. tapa carril  
5113/001 2 u. tapa lateral carril  
5110/001 1 u. set pinzas portavidrio  
4207/001 1 u. uñero

Incluye guiador de suelo

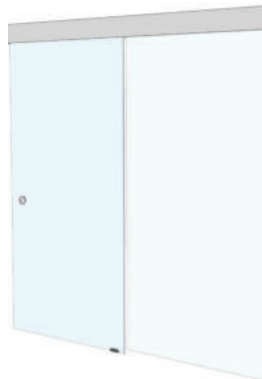

5126/T21 2 m  
5126/T31 3 m  
KIT PUERTA CORREDERA DE CRISTAL CON VIDRIO FIJO  
KIT PORTE COULISSANTE EN VERRE AVEC VITRE FIXE  
SLIDING GLASS DOOR KIT WITH FIXED GLASS  
KIT PORTA SCORREVOLE IN VETRO CON VETROFISSO  
5111/201-5111/301 1 u. carril  
5114/201-5114/301 1 u. carril fijo  
5112/201-5112/301 2 u. tapa carril  
5113/001 2 u. tapa lateral carril  
5110/001 1 u. set pinzas portavidrio  
4207/001 1 u. uñero

Incluye guiador de suelo

## PARA PUERTAS CORREDERAS DE MADERA

POUR PORTES COULISSANTES EN BOIS - FOR WOODEN SLIDING DOORS  
PER PORTE SCORREVOLI IN LEGNO

VER PÁG. M2



5120/E21 2 m  
5120/E31 3 m  
KIT PUERTA CORREDERA PARA MADERA  
EMPOTRABLE EN EL TECHO  
KIT PORTE COULISSANTE BOIS AU PLAFOND  
KIT SLIDINGDOOR RECESSED IN THE CEILING  
KIT PORTA SCORREVOLE INCASSATA NEL SOFFITTO  
5111/201-5111/301 1 u. carril  
5115/001 2 u. set pinzas para madera  
4207/001 1 u. uñero

5121/P21 2 m  
5121/P31 3 m  
KIT PUERTA CORREDERA PARA MADERA A PARED  
KIT DE PORTE COULISSANTE BOIS AU MUR  
KIT SLIDING DOOR FIXED TO THE WALL  
KIT PORTA SCORREVOLE FISSATA A PARETE  
5111/201 1 u. carril  
5116/201 1 u. tapa carril  
5117/001 2 u. tapa lateral carril  
5115/001 2 u. set pinzas para madera  
4207/001 1 u. uñero

## PUERTAS DE PASO - MARCO

### POSIBLES APLICACIONES



### CANTÓN MARCO

1 Fijo (opcional / DER) + 1 Puerta corredera

## PUERTAS DE PASO - MARCO

### JAPONESA

1 Puerta corredera



## PUERTAS CORREDERAS CON PERFIL DE ALUMINIO



# PUERTAS DE PASO - MARCO

## CANTÓN MARCO EN COLORES

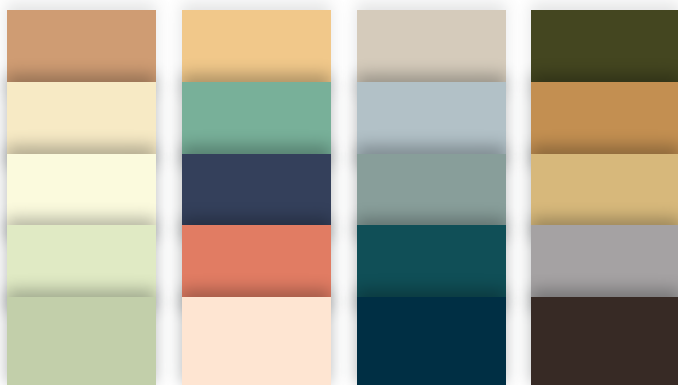

**ELIGE EL RAL  
QUE QUIERAS**

**PERSONALIZA  
LOS ESPACIOS  
CON LOS COLORES**

## PUERTAS DE PASO - MARCO



POSIBILIDAD DE  
CREAR PUERTAS  
JAPONESAS



- 1 PUERTA CORREDERA
- 1 PUERTA CORREDERA + 1 FIJO
- 2 PUERTAS CORREDERAS



# PUERTAS DE PASO - MARCO

## POSIBLES APLICACIONES

### MARCO 1

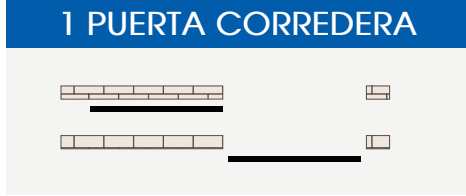

**A** ALINEADO EN PARKING

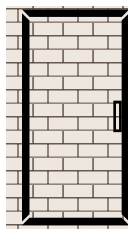

**B** TIRADOR SALIENTE

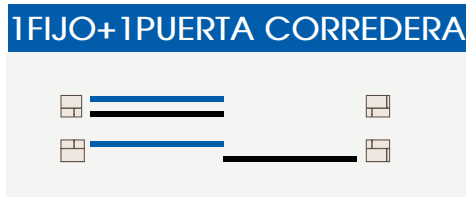
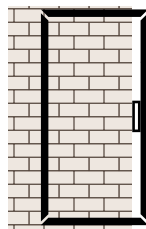

**A** ALINEADO EN PARKING

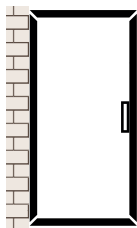

**B** TIRADOR SALIENTE

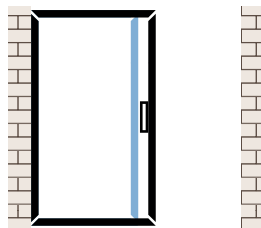

### MARCO 2

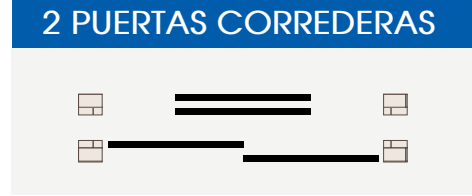

ABIERTO

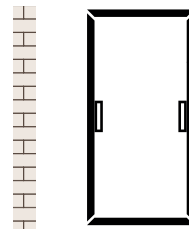

CERRADO

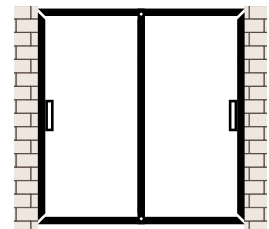

# PUERTAS DE PASO - MARCO

## DATOS GENERALES

### ACABADOS

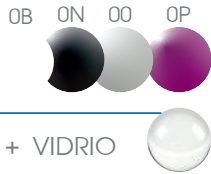

Puerta de vidrio y marco de aluminio/  
Marco disponible en bruto para pintar en cualquier RAL.

Vidrio de 8 mm

+ VIDRIO

\* Para otros acabados, consultar pedido mínimo y plazo de entrega.

### PESO



80 Kg max por hoja

### CARACTERÍSTICAS

Deslizamiento suave  
Soft-closing en apertura y cierre  
Diferentes posibilidades.  
Posibilidad de crear una estructura japonesa personalizada.

### SECCIONES PERFILES

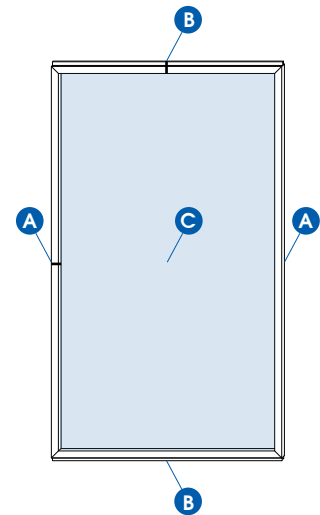
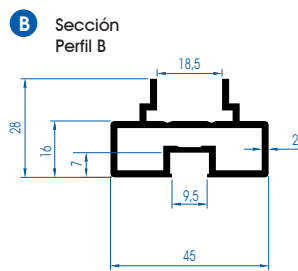
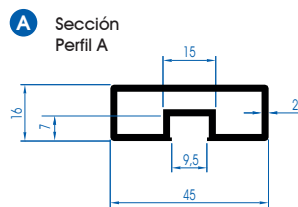

### ANCLAJE

#### ANCLAJE TECHO

Instalación a techo  
Ceiling mounted

#### ANCLAJE PARED

Instalación a pared  
Wall mounted

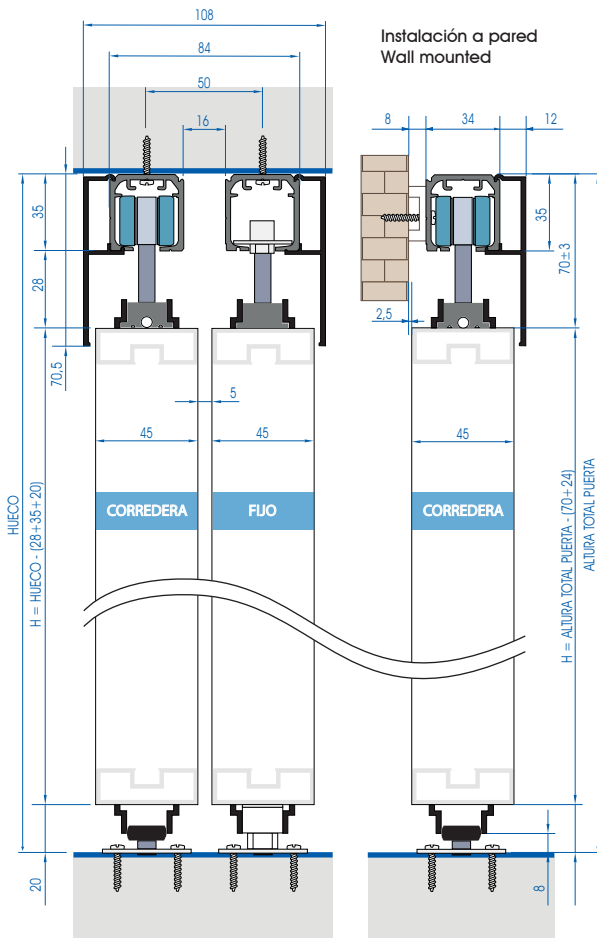

### MEDIDAS VIDRIO

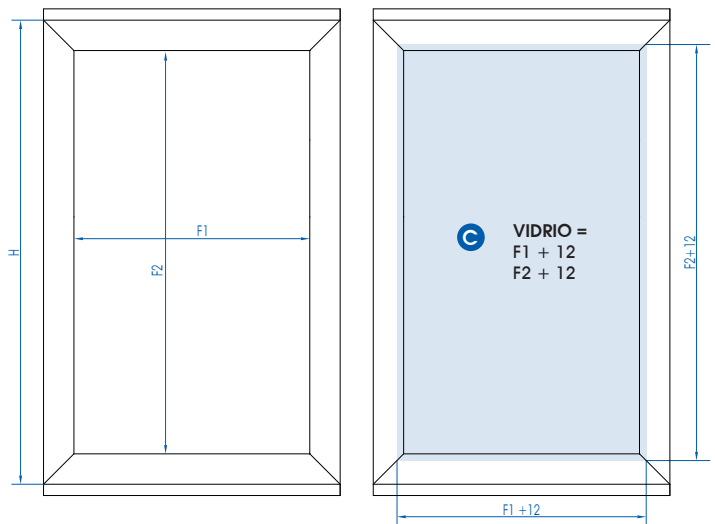

# PUERTAS DE PASO - MARCO

## CARRIL

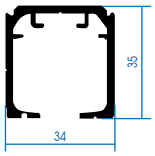

**CARRIL SUPERIOR**  
RAIL EN ALUMINIUM  
ALUMINIUM RAIL  
BINARIO IN ALLUMINIO  
5111/20. 2M  
5111/30. 3M  
5111/40. 4M

BLANCO BLANC WHITE BIANCO	NEGRO NOIR BLACK NERO	BRUTO BRUT RAW GREZZO	COLOR COULEUR COLOR COLORE
0B	0N	00	0P

Al	2M	3M	4M	€/u

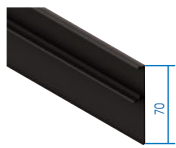

**TAPA DE CARRIL SUPERIOR**  
COUVERTURE DE RAIL  
SUPÉRIEURE  
TOP RAIL COVER  
COPERTURA SUPERIORE DEL  
BINARIO  
5210/20. 2M  
5210/30. 3M  
5210/40. 4M

Al	2M	3M	4M	€/u

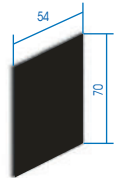

**TAPA LATERAL**  
X  
ENDCAP  
Y  
5123/00.

Al				€/u

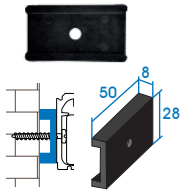

**SEPARADOR DE PARED**  
SÉPARATEUR MURAL  
WALL SPACER  
Distanziatore  
5124/00N

Pl				€/u

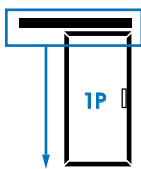

**SET COJINETES PARA 1 PUERTA**  
JEU DE ROULEMENTS POUR 1 PORTE  
SET OF FITTINGS FOR 1 DOOR  
SET CUSCINETTI PER 1 ANTE  
5122/00N selfclosing

				€/u

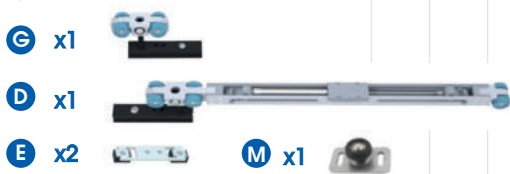

- D** Bufer  
- bufer  
- cojinete pequeño
- E** Frenos tipo bufer
- G** Cojinete pequeño sin ruedita  
- carro  
- cojinete pequeño
- M** Gulador en suelo

# PUERTAS DE PASO - MARCO

## MARCOS

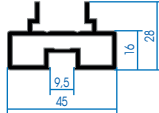

**PERFIL INTERIOR Y SUPERIOR (MARCO)**  
PROFIL DE CADRE SUPÉRIEUR ET INFÉRIEUR  
UPPER AND BOTTOM  
FRAME PROFILE  
PROFILO SUPERIORE E  
INFERIORE CORNICE  
5205/20.

Al	2M			€/u

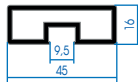

**PERFIL LATERAL (MARCO)**  
PROFIL DE CADRE LATÉRAL  
LATERAL FRAME PROFILE  
PROFILO LATERALE CORNICE  
5206/30.

Al	3M			€/u



**ESQUADRA UNIÓN PERFILES**  
SUPPORT POUR ASSEMBLER DES PROFILS  
BRACKET FOR JOINING PROFILES  
GIUNTO UNIONE PROFILI  
5207/000

Al				€/u



**GALGA ESCUADRA / MECANIZACIÓN PERFIL**  
JAUGE CARREE  
BRACKET GAUGE  
CALIBRO SQUADRA  
5207/010

Pl				€/u



**CINTA ADHESIVA VIDRIO**  
RUBAN ADHÉSIF DOUBLE FACE EN VERRE  
GLASS DOUBLE SIDED TAPE  
NASTRO BIADESIVO VETRO  
5209/109  
5209/009 ROLLO DE 33M

Pl				€/m

## KIT 1 PUERTA

**KI MARCO DE ALUMINIO 3X1M (1 PUERTA)**  
KIT CADRE DE ALUMINIUM  
3X1M (1 PORTÉ)  
SET ALUMINIUM FRAME  
3X1M (1 FRAME)  
CONGIUNTO PERIMETRALE  
DI ALLUMINIO 3X1M  
5204/00. ancho hasta 95cm  
5204/01. ancho más de 95cm

Al	3M			€/u

- N** x2
- P** x4
- Q** x1
- O** x2

- N** Perfil interior y superior (marco)
- O** Perfil lateral (marco)
- P** Esquadra unión perfiles
- Q** Cinta adhesiva vidrio





# PUERTAS DE PASO - MARCO

## ACCESORIOS



**TIRADOR DOBLE PARA MARCO DE ALUMINIO**  
 POIGNÉE DOUBLE POUR CADRE EN ALUMINIUM  
 DOUBLE HANDLE FOR ALUMINIUM FRAME  
 MANIGLIA DOPPIA TELAIO IN ALLUMINIUM  
**5208/00.**

Al	213x46x13mm	€/u
----	-------------	-----

○ ○ ○ ○



**TIRADOR DOBLE CON PESTILLO PICO DE LORO**  
 DOUBLE POIGNÉE DE VERROUILLAGE  
 DOUBLE HANDLE WITH LATCH  
 MANIGLIA DOPPIA CON CHIAVISTELLO  
**5216/00N**

Al	213x46x13mm	€/u
----	-------------	-----

○



**CERRADURA DE PUERTA ENMARCADA CON LLAVE PICO DE LORO**  
 SERRURE DE PORTE ENCADRÉE AVEC CLÉ  
 FRAMED DOOR LOCK WITH KEY  
 SERRATURA PER PORTE CON CORNICE CON CHIAVE  
**5215/00N**

Al	104x77x15mm	€/u
----	-------------	-----

○



**ANCLAJE PARA MARCO DE PUERTA FIJA**  
 ANCRAGE DE CADRE DE PORTE FIXE  
 FIXED DOOR FRAME ANCHOR  
 ANCORAGGIO TELAIO PORTA FISSO  
**5203/000**

lx		€/u
----	--	-----

○



Al	3M	15,6x10,1mm	€/m
----	----	-------------	-----

Ⓢ 5209/109



**PERFIL ALUMINIO PARA CRISTAL-PUERTA DE PANEL JAPONÉS**  
 PROFILÉ EN ALUMINIUM POUR LE VERRE DANS LA PORTE À PANNEAU JAPONAIS.  
 ALUMINIUM PROFILE FOR GLASS IN JAPANESE PANEL DOOR.  
 PROFILO IN ALLUMINIO PER VETRO IN ANTA A PANNELLO GIAPPONESE.  
**5127/30.**

○ ○ ○ ○

Instrucciones de montaje en la página 11.



**PERFIL INTERIOR Y SUPERIOR (MARCO)**  
 PROFILÉ DE FINITION "L"  
 "L" FINISHING PROFILE  
 PROFILO DI FINITURA A "L"  
**5202/10.**

Al	2M	40x10x0,8mm	€/m
----	----	-------------	-----

○ ○ ○ ○

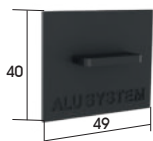

**TAPETA EMBELLECEDORA**  
 PROFILÉ DE FINITION "L"  
 "L" FINISHING PROFILE  
 PROFILO DI FINITURA A "L"  
**85205/00N**

Pi	40x10x0,8mm	€/m
----	-------------	-----

○

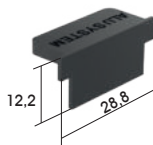

**TAPETA EMBELLECEDORA**  
 PROFILÉ DE FINITION "L"  
 "L" FINISHING PROFILE  
 PROFILO DI FINITURA A "L"  
**85203/00N**

Pi	40x10x0,8mm	€/m
----	-------------	-----

○

# PUERTAS DE PASO - MARCO

## KITS

### MARCO 1

1 PUERTA CORREDERA



**ANCHO PUERTA HASTA 95**  
 CARRIL 2M

REF. 5150/00.

- X1 5111/20.
- X1 5210/20.
- X1 5122/00N
- X1 5204/00.
- X1 5208/00.
- X5 5124/00N
- X2 5123/00N

**ANCHO PUERTA MÁS DE 95**  
 CARRIL 3M

REF. 5150/01.

- X1 5111/30.
- X1 5210/30.
- X1 5122/00N
- X1 5204/01.
- X1 5208/00.
- X7 5124/00N
- X2 5123/00N



5150/00. ○ ○ ○ ○  
 5150/01. ○ ○ ○ ○

### MARCO 1

1 FIJO + 1 PUERTA CORREDERA



**ANCHO PUERTA HASTA 95**  
 CARRIL 2M

REF. 5151/00.

- X2 5111/20.
- X2 5210/20.
- X1 5122/00N
- X2 5204/00.
- X1 5208/00.
- X1 5203/00.

**ANCHO PUERTA MÁS DE 95**  
 CARRIL 3M

REF. 5151/01.

- X2 5111/30.
- X2 5210/30.
- X1 5122/00N
- X2 5204/01.
- X1 5208/00.
- X1 5203/00.



5151/00. ○ ○ ○ ○  
 5151/01. ○ ○ ○ ○

### MARCO 2

2 PUERTAS CORREDERAS

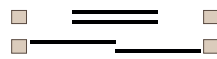

**ANCHO PUERTA HASTA 95**  
 CARRIL 2M

REF. 5152/00.

- X2 5111/20.
- X2 5210/20.
- X2 5122/00N
- X2 5204/00.
- X2 5208/00.

**ANCHO PUERTA MÁS DE 95**  
 CARRIL 3M

REF. 5152/01.

- X2 5111/30.
- X2 5210/30.
- X2 5122/00N
- X2 5204/01.
- X2 5208/00.



5152/00. ○ ○ ○ ○  
 5152/01. ○ ○ ○ ○

# PUERTAS DE PASO - CANTÓN MARCO INVISIBLE

## PUERTA CORREDERA CON MECANISMO OCULTO

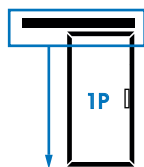

**KIT COJINETES Y GUÍAS PARA 1 PUERTA**  
 JEU DE ROULEMENTS POUR 1 PORTE  
 SET OF FITTINGS FOR 1 DOOR  
 SET CUSCINETTI PER 1 ANTE  
**5230/00N selfclosing**

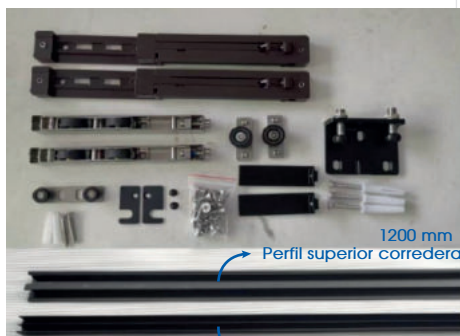

1200 mm  
 Perfil superior corredera  
 Perfil inferior puerta  
 1200 mm

NEGRO  
 NOIR  
 BLACK  
 NERO  
**0N**

€/u

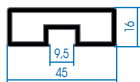

**PERFIL LATERAL (MARCO)**  
 PROFIL DE CADRE LATÉRAL  
 LATERAL FRAME PROFILE  
 PROFILO LATERALE CORNICE  
**5206/30.**



**ESQUADRA UNIÓN PERFILES**  
 SUPPORT POUR ASSEMBLER DES PROFILS  
 BRACKET FOR JOINING PROFILES  
 GIUNTO UNIONE PROFILI  
**5207/000**



**GALGA ESQUADRA / MECANIZACIÓN PERFIL**  
 JAUGE CARRÉE  
 BRACKET GAUGE  
 CALIBRO SQUADRA  
**5207/010**

BLANCO  
 BLANC  
 WHITE  
 BIANCO  
**0B**

NEGRO  
 NOIR  
 BLACK  
 NERO  
**0N**

BRUTO  
 BRUT  
 RAW  
 GREZZO  
**00**

COLOR  
 COULEUR  
 COLOR  
 COLORE  
**0P**

Al  3M €/u

Al  €/u

PLÁSTICO  
 PLASTIQUE  
 PLASTIC  
 PLASTICA  
**09**

Pla  €/u

# PUERTAS DE PASO - CANTÓN MARCO INVISIBLE

## PUERTA CORREDERA CON MECANISMO OCULTO

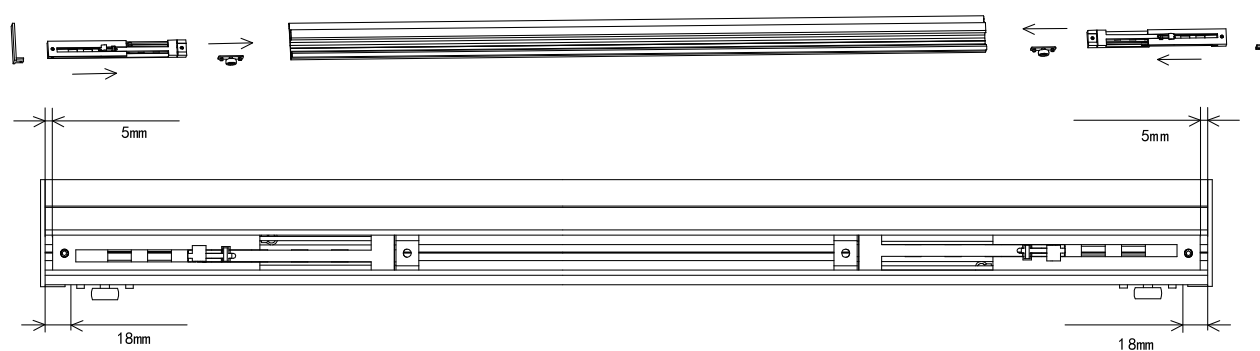
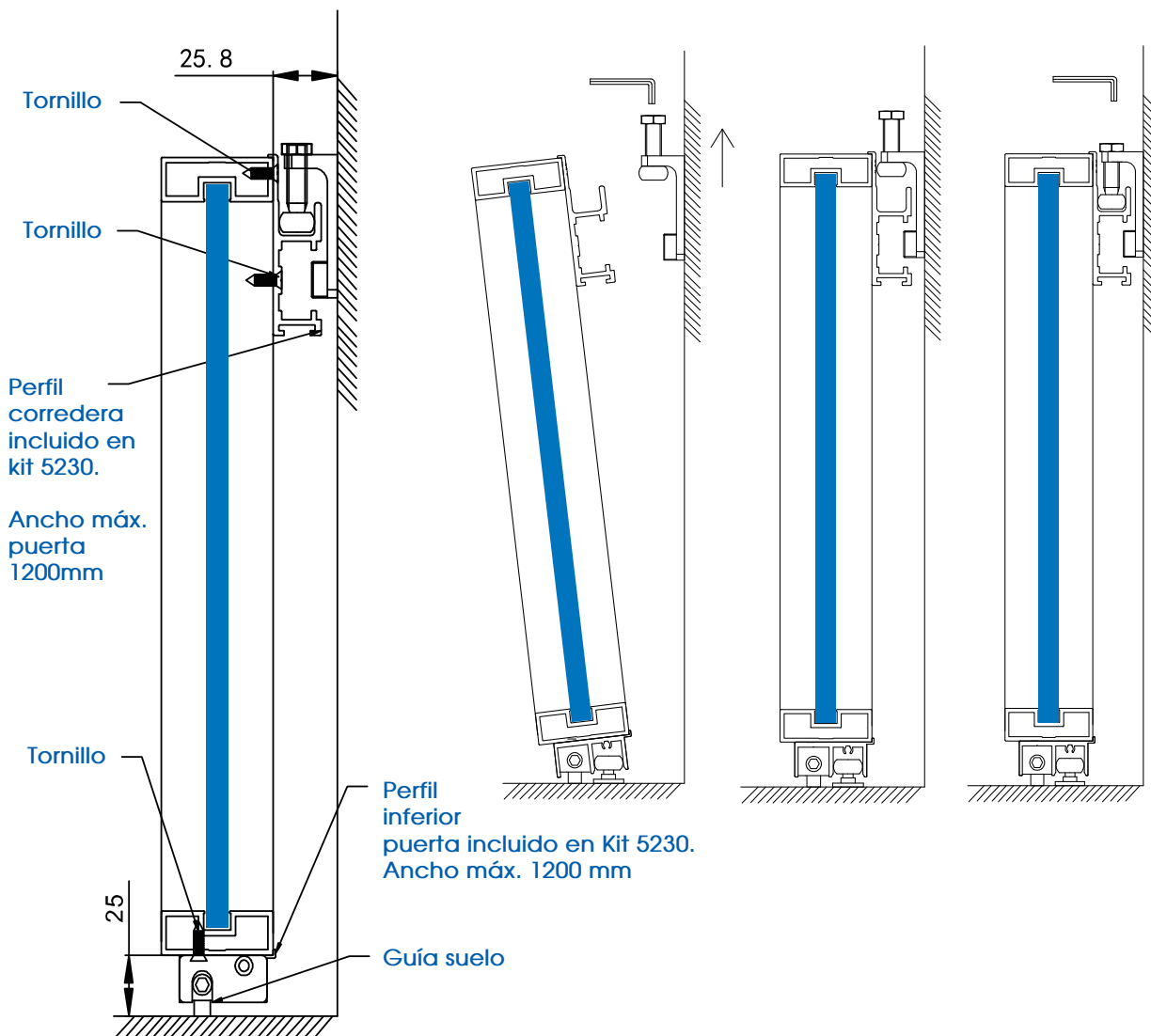

## PUERTAS DE PASO - MARCO TELEX

### POSIBLES APLICACIONES

### DIFERENTES POSIBILIDADES Y APLICACIONES

PUERTAS TELESCÓPICAS  
CON PERFIL DE ALUMINIO

### CANTÓN TELEX 2

1 Fijo (opcional) +  
2 Puertas correderas



## PUERTAS DE PASO - MARCO TELEX



### CANTÓN TELEX 3

1 Fijo (opcional)  
+ 3 Puertas  
correderas

# PUERTAS DE PASO - MARCO TELEX

## CANTÓN MARCO TELEX EN

## COLORES

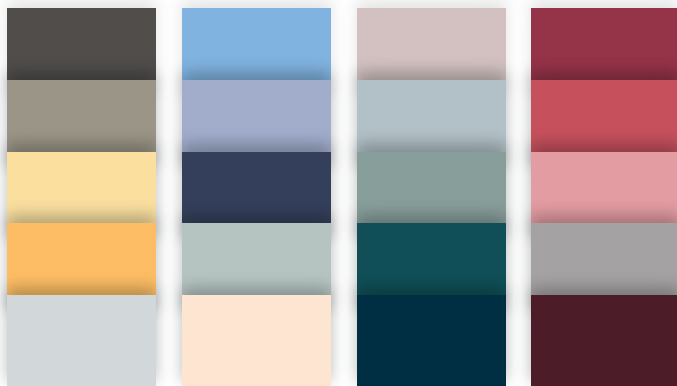

## PUERTAS TELESCÓPICAS CON PERFIL DE ALUMINIO - COLOR PERSONALIZABLE



**ELIGE EL RAL QUE QUIERAS**  
**PERSONALIZA LOS ESPACIOS CON LOS COLORES**

## PUERTAS DE PASO - MARCO TELEX

- **TELEX 2** PUERTAS CORREDERAS
- **TELEX 2** PUERTAS CORREDERAS + 1 FIJO
- **TELEX 3** PUERTAS CORREDERAS
- **TELEX 3** PUERTAS CORREDERAS + 1 FIJO

\* **POSIBILIDAD DE  
CREAR PUERTAS  
JAPONESAS**



**TELEX 2 (+ FIJO OPCIONAL)**



**TELEX 3 (+ FIJO OPCIONAL)**



# PUERTAS DE PASO - MARCO TELEX

## POSIBLES APLICACIONES

### CANTÓN TELEX 2

### CANTÓN TELEX 3

#### 2 PUERTAS CORREDERAS TELESCÓPICAS

#### 3 PUERTAS CORREDERAS TELESCÓPICAS

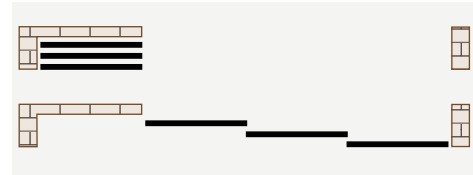
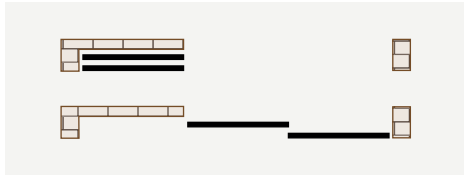

- A** ALINEADO EN PARKING
- B** 1ª PUERTA - TIRADOR SALIENTE

- A** ALINEADO EN PARKING
- B** 1ª PUERTA - TIRADOR SALIENTE

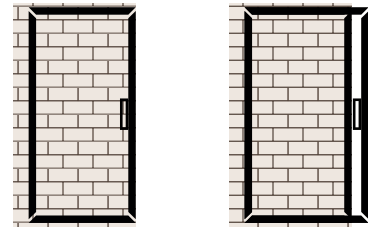
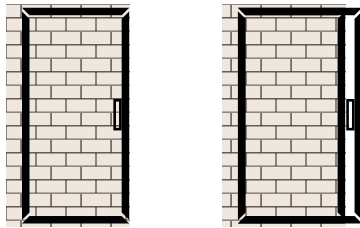

#### 1 FIJO + 2 PUERTAS CORREDERAS TELESCÓPICAS

#### 1 FIJO + 3 PUERTAS CORREDERAS TELESCÓPICAS



- A** ALINEADO EN PARKING
- B** TIRADOR SALIENTE

- A** ALINEADO EN PARKING
- B** TIRADOR SALIENTE

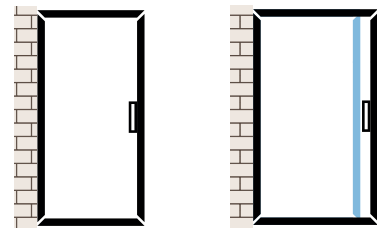
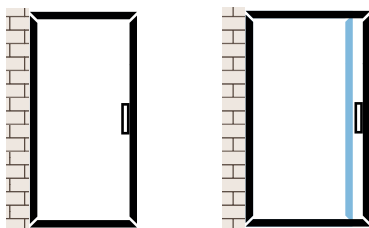

## DATOS GENERALES

**PESO**  80 Kg max por hoja

### CARACTERÍSTICAS

Apertura sincronizada  
Deslizamiento suave  
Soft-closing en apertura y cierre

### ACABADOS



**VIDRIO**  
Puerta de vidrio / Marco en aluminio negro



Vidrio de 8 mm



**MADERA**  
Puerta de madera / Marco en aluminio negro





# PUERTAS DE PASO - MARCO TELEX

## DATOS TÉCNICOS

### SECCIONES PERFILES

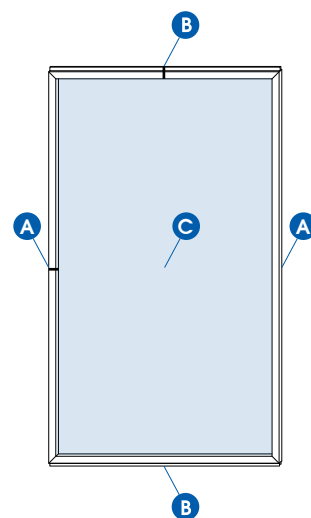
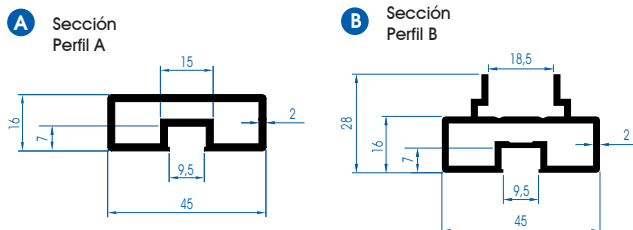

### MEDIDAS VIDRIO

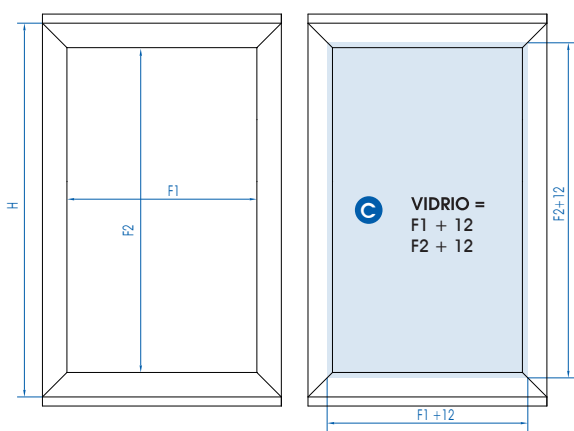

### ANCLAJE

Instalación a techo  
Ceiling mounted

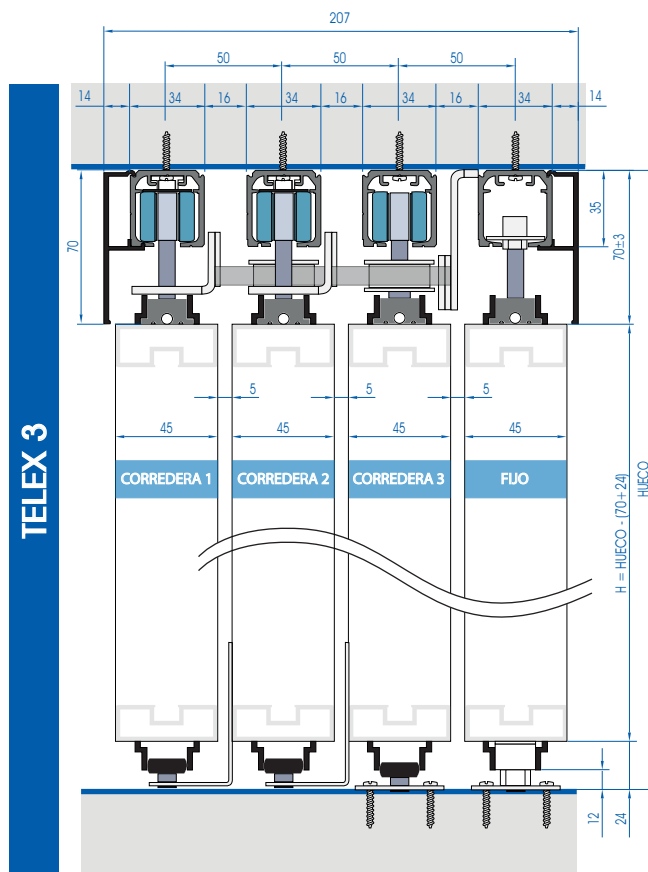
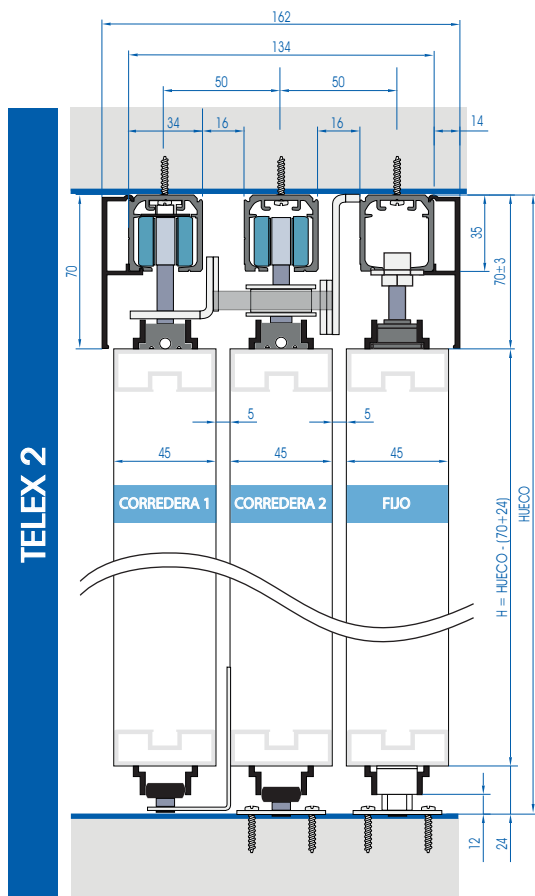

# PUERTAS DE PASO - MARCO TELEX

## CÁLCULO DE MEDIDAS TELEX 2

### CANTÓN TELEX 2

2 PUERTAS CORREDERAS  
ALINEADAS EN PARKING

Ancho mínimo de puerta 2180mm  
max. 2811mm

F = MEDIDA PUERTA FIJA  
A = MEDIDA PUERTAS CORREDERAS

$$F = \frac{(\text{HUECO} + 32)}{3} + 5$$

$$A = \frac{L}{2} + 16$$

$$L = \text{HUECO} - F$$

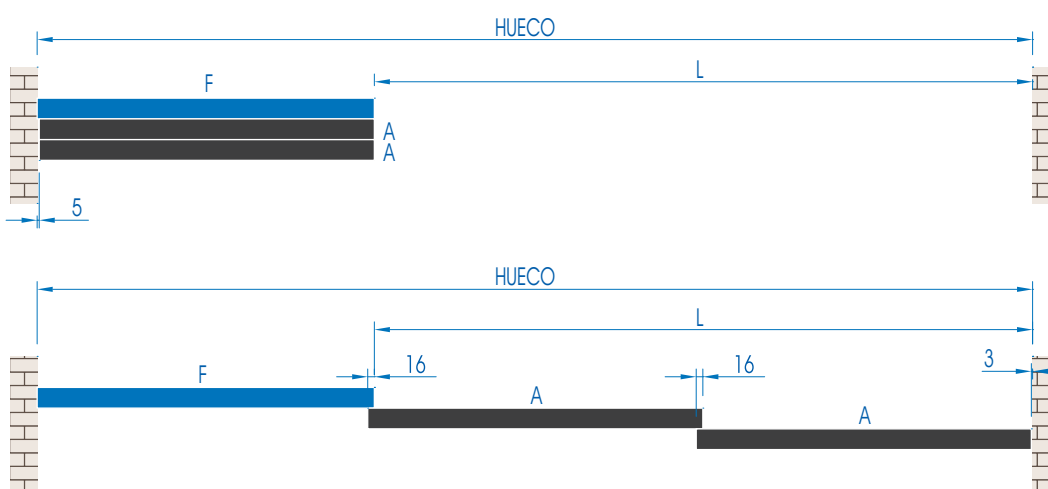

2 PUERTAS CORREDERAS  
CON TIRADOR SALIENTE

Ancho mínimo de puerta 2260mm  
max. 2666mm

G = MEDIDA SALIENTE PARA EL TIRADOR  
F = MEDIDA PUERTA FIJA  
A = MEDIDA PUERTA CORREDERA INTERMEDIA  
B = PUERTA FINAL CON TIRADOR SALIENTE

$$F = \frac{(\text{HUECO} - 3 - 5 - G + 16 \times 2)}{3} + 5$$

$$A = \frac{(\text{HUECO} - 3 - 5 - G + 16 \times 2)}{3}$$

$$L = \text{HUECO} - F$$

$$B = A + G$$

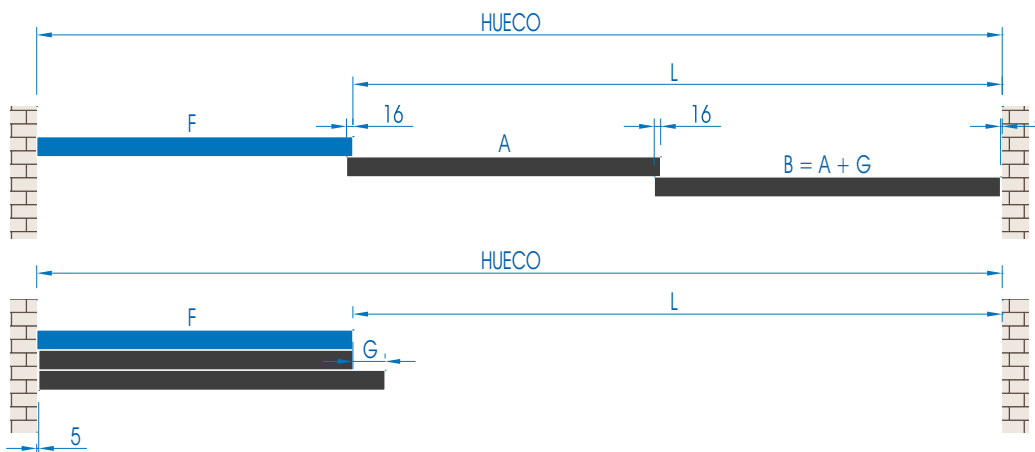

# PUERTAS DE PASO - MARCO TELEX

## CÁLCULO DE MEDIDAS TELEX 3

### CANTÓN TELEX 3

3 PUERTAS CORREDERAS  
ALINEADAS EN PARKING

Ancho mínimo de puerta 2900mm  
max. 3740mm

F = MEDIDA PUERTA FIJA  
A = MEDIDA PUERTAS CORREDERAS

$$F = \frac{\text{HUECO} + 58}{4}$$

$$A = \frac{L}{3} + 15$$

$$L = \text{HUECO} - F$$

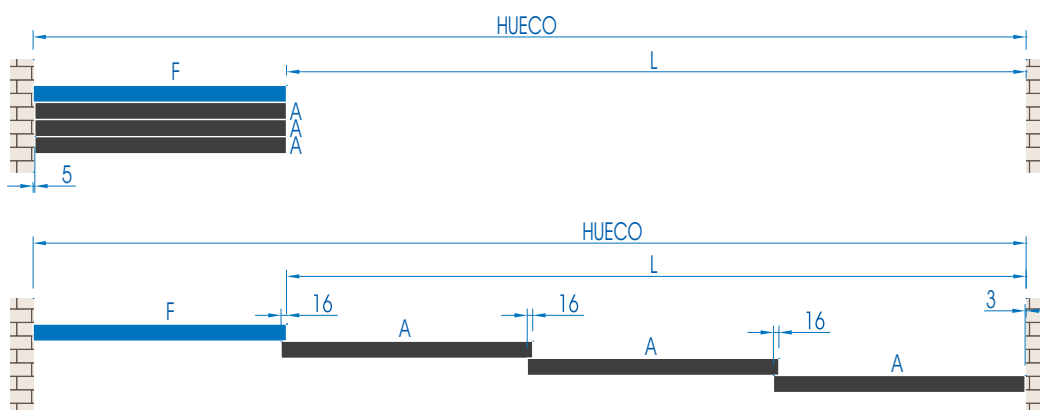

3 PUERTAS CORREDERAS  
CON TIRADOR SALIENTE

Ancho mínimo de puerta 2980mm  
max. 3520mm

G = MEDIDA SALIENTE PARA EL TIRADOR  
F = MEDIDA PUERTA FIJA  
A = MEDIDA PUERTAS CORREDERAS INTERMEDIAS  
B = PUERTA FINAL CON TIRADOR SALIENTE

$$F = \frac{\text{HUECO} - G}{4} + 16$$

$$F = \text{HUECO} - L$$

$$A = \frac{L - G}{3} + 15$$

$$B = \frac{L - G}{3} + G + 15$$

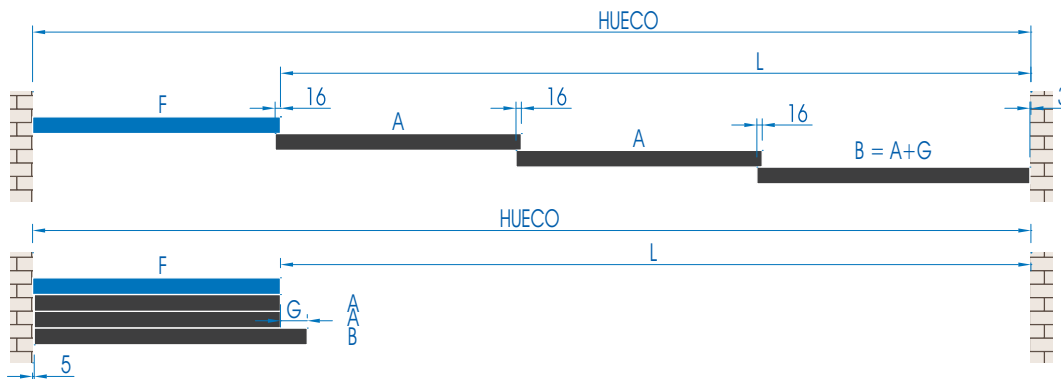

\* SOLICITE LA HOJA DE  
CÁLCULO DE MEDIDAS

# PUERTAS DE PASO - MARCO TELEX 2

## CARRIL

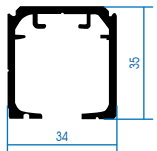

**CARRIL SUPERIOR**  
RAIL EN ALUMINIUM  
ALUMINIUM RAIL  
BINARIO IN ALLUMINIO  
5111/30. 3M

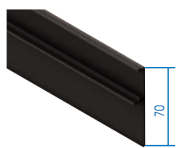

**TAPA DE CARRIL SUPERIOR**  
COUVERTURE DE RAIL  
SUPÉRIEURE  
TOP RAIL COVER  
COPERTURA SUPERIORE DEL  
BINARIO  
5210/30. 3M

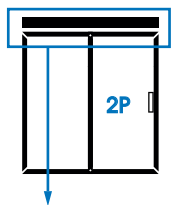

**SET COJINETES PARA 2 PUERTAS TELESCÓPICAS**  
JEU DE ROULEMENTS POUR 2 PORTES TÉLESCOPIQUES  
SET OF FITTINGS FOR 2 TELESCOPIC DOORS  
SET CUSCINETTI PER 2 ANTE TELESCOPICHE  
5200/00N SELF-CLOSING



**B** Kit cojnete grande con ruedita  
- carro  
- ruedita  
- cojnete grande

**C** Frenos tipo cubo

**D** Kit bufer  
- bufer  
- cojnete pequeño

**E** Frenos tipo bufer

**F** Kit cojnete pequeño con ruedita  
- carro  
- ruedita  
- cojnete pequeño

**G** Kit cojnete pequeño sin ruedita  
- carro  
- cojnete pequeño

**H** Sujeta correa en techo

**I** Sujeta correa en cojnete

**J** Correa

**K** Pinza de correa

**L** Guiador en puerta

**M** Guiador en suelo

BLANCO BLANC WHITE BIANCO	NEGRO NOIR BLACK NERO	BRUTO BRUT RAW GREZZO	COLOR COULEUR COLOR COLORE
OB	ON	OO	OP
<input type="checkbox"/>	<input type="checkbox"/>	<input type="checkbox"/>	<input type="checkbox"/>
<input type="checkbox"/>	<input type="checkbox"/>	<input type="checkbox"/>	<input type="checkbox"/>
			<input type="checkbox"/>

# PUERTAS DE PASO - MARCO TELEX 2

## MARCOS

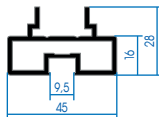

**PERFIL INFERIOR Y SUPERIOR (MARCO)**  
PROFIL DE CADRE SUPÉRIEUR ET INFÉRIEUR  
UPPER AND BOTTOM FRAME PROFILE  
PROFILO SUPERIORE E INFERIORE CORNICE  
5205/20.

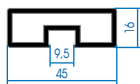
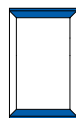

**PERFIL LATERAL (MARCO)**  
PROFIL DE CADRE LATÉRAL  
LATERAL FRAME PROFILE  
PROFILO LATERALE CORNICE  
5206/30.

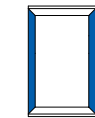

**ESCUADRA UNIÓN PERFILES**  
SUPPORT POUR ASSEMBLER DES PROFILS  
BRACKET FOR JOINING PROFILES  
GIUNTO UNIONE PROFILI  
5207/000



**GALGA ESCUADRA / MECANIZACIÓN PERFIL**  
JAUGE CARRÉE  
BRACKET GAUGE  
CALIBRO SQUADRA  
5207/010



**KIT MARCO DE ALUMINIO 3X1M (1 PUERTA)**  
KIT CADRE DE ALUMINIUM 3X1M (1 PORTÉ)  
SET ALUMINIUM FRAME 3X1M (1 FRAME)  
CONGIUNTO PERIMETRALE DI ALLUMINIO 3X1M  
5204/00. gncho hasta 95cm  
5204/01. gncho más de 95cm

BLANCO BLANC WHITE BIANCO	NEGRO NOIR BLACK NERO	BRUTO BRUT RAW GREZZO	COLOR COULEUR COLOR COLORE
OB	ON	OO	OP
<input type="checkbox"/>	<input type="checkbox"/>	<input type="checkbox"/>	<input type="checkbox"/>
<input type="checkbox"/>	<input type="checkbox"/>	<input type="checkbox"/>	<input type="checkbox"/>
			<input type="checkbox"/>
			<input type="checkbox"/>
			<input type="checkbox"/>
			<input type="checkbox"/>
			<input type="checkbox"/>
			<input type="checkbox"/>
			<input type="checkbox"/>



**N** Perfil inferior y superior (marco)

**O** Perfil lateral (marco)

**P** Escuadra unión perfiles

**Q** Cinta adhesiva vidrio

# PUERTAS DE PASO - MARCO TELEX 2

## ACCESORIOS

BLANCO BLANC WHITE BIANCO	NEGRO NOIR BLACK NERO	BRUTO BRUT RAW GREZZO	COLOR COULEUR COLOR COLORE
OB	ON	OO	OP



**TIRADOR DOBLE PARA MARCO DE ALUMINIO**  
POIGNÉE DOUBLE POUR CADRE EN ALUMINIUM  
DOUBLE HANDLE FOR ALUMINIUM FRAME  
MANIGLIA DOPPIA TELAIO IN ALLUMINIO  
5208/00.

Al	213x46x13mm	€/u
----	-------------	-----

○ ○ ○ ○



**TIRADOR DOBLE CON PESTILLO PICO DE LORO**  
DOUBLE POIGNÉE DE VERROUILLAGE  
DOUBLE HANDLE WITH LATCH  
MANIGLIA DOPPIA CON CHIAVISTELLO  
5216/00N

Al	213x46x13mm	€/u
----	-------------	-----

○



**CERRADURA DE PUERTA ENMARCADA CON LLAVE PICO DE LORO**  
SERRURE DE PORTE ENCADRÉE AVEC CLÉ  
FRAMED DOOR LOCK WITH KEY  
SERRATURA PER PORTE CON CORNICE CON CHIAVE  
5215/00N

Al	104x77x15mm	€/u
----	-------------	-----

○



CARRIL

**ANCLAJE PARA MARCO DE PUERTA FIJA**  
ANCRAGE DE CADRE DE PORTE FIXE  
FIXED DOOR FRAME ANCHOR  
ANCORAGGIO TELAIO PORTA FISSO  
5203/000

lx		€/u
----	--	-----

○



SUELO

**PERFIL ALUMINIO PARA CRISTAL-PUERTA DE PANEL JAPONÉS**  
PROFILÉ EN ALUMINIUM POUR LE VERRE DANS LA PORTE À PANNEAU JAPONAIS.  
ALUMINIUM PROFILE FOR GLASS IN JAPANESE PANEL DOOR.  
PROFILO IN ALLUMINIO PER VETRO IN ANTA A PANNELLO GIAPPONESE.  
5127/30.

Al	15,6x10,1mm	€/u
----	-------------	-----

⊙ 5209	↳ 3 m
--------	-------

○ ○ ○ ○

Instrucciones de montaje en la página 15.



**PERFIL EMBELLECEDOR EN "L"**  
PROFILÉ DE FINITION "L"  
"L" FINISHING PROFILE  
PROFILO DI FINITURA A "L"  
5202/10.

Al	40x10x0,8mm	€/m
----	-------------	-----

↳ 2 m
-------

○ ○ ○ ○



**TAPETA EMBELLECEDORA**  
PROFILÉ DE FINITION "L"  
"L" FINISHING PROFILE  
PROFILO DI FINITURA A "L"  
85205/00N

PI	40x10x0,8mm	€/m
----	-------------	-----

○

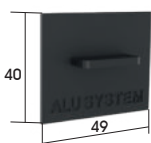

**TAPETA EMBELLECEDORA**  
PROFILÉ DE FINITION "L"  
"L" FINISHING PROFILE  
PROFILO DI FINITURA A "L"  
85203/00N

PI	40x10x0,8mm	€/m
----	-------------	-----

○

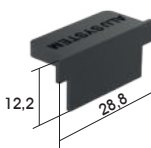

# PUERTAS DE PASO - MARCO TELEX 2

## KITS PUERTA COMPLETA

BLANCO BLANC WHITE BIANCO	NEGRO NOIR BLACK NERO	BRUTO BRUT RAW GREZZO	COLOR COULEUR COLOR COLORE
OB	ON	OO	OP

**TELEX 2**  
2 puertas telescópicas



**ANCHO PUERTA HASTA 95**  
CARRIL 3M

**ANCHO PUERTA MÁS DE 95**  
CARRIL 3M

REF. 5211/00.

REF. 5211/01.

- X2 5111/30.
- X2 5210/30.
- X1 5200/00N
- X2 5204/00.
- X1 5208/00.

- X2 5111/30.
- X2 5210/30.
- X1 5200/00N
- X2 5204/01.
- X1 5208/00.

5211/00. ○ ○ ○ ○  
5211/01. ○ ○ ○ ○

**TELEX 2**  
1 fijo + 2 puertas telescópicas



**ANCHO PUERTA HASTA 95**  
CARRIL 3M

**ANCHO PUERTA MÁS DE 95**  
CARRIL 3M

REF. 5212/00.

REF. 5212/01.

- X3 5111/30.
- X2 5210/30.
- X1 5200/00N
- X3 5204/00.
- X1 5208/00.
- X1 5203/000

- X3 5111/30.
- X2 5210/30.
- X1 5200/00N
- X3 5204/01.
- X1 5208/00.
- X1 5203/000

5212/00. ○ ○ ○ ○  
5212/01. ○ ○ ○ ○



**3M CINTA AUTOADHESIVA. VIDRIO MAX. CALIDAD. TRANSPARENTE. PARA PERFILES PUERTA JAPONESA**  
RUBAN ADHÉSIF DOUBLE FACE EN VERRE  
GLASS DOUBLE SIDED TAPE  
NASTRO BIADHESIVO VETRO  
5209/109  
5209/009 ROLLO DE 33M

Pla		€/m
-----	--	-----

PLÁSTICO  
PLASTIC  
PLASTIC  
PLASTICA  
09

○

○

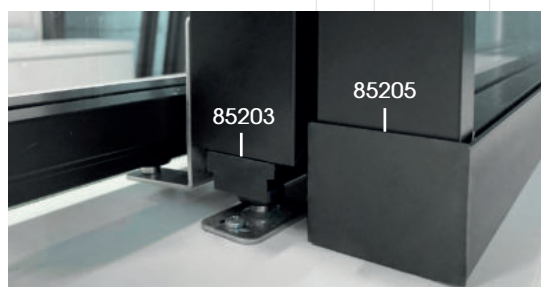

# PUERTAS DE PASO - MARCO TELEX 3

## CARRIL

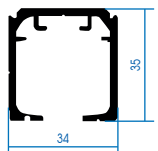

CARRIL SUPERIOR  
RAIL EN ALUMINIUM  
ALUMINIUM RAIL  
BINARIO IN ALLUMINIO  
5111/40. 4M

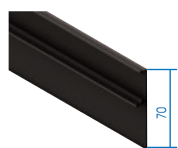

TAPA DE CARRIL SUPERIOR  
COUVERTURE DE RAIL  
SUPÉRIEURE  
TOP RAIL COVER  
COPERTURA SUPERIORE  
DEL BINARIO  
5210/40. 4M

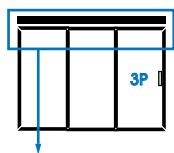

SET COJINETES PARA 3 PUERTAS  
TELESCÓPICAS  
JEU DE ROULEMENTS POUR 3  
PORTES TÉLESCOPIQUES  
SET OF FITTINGS FOR 3 TELESCOPIC  
DOORS  
SET CUSCINETTI PER 3 ANTE  
TELESCOPICHE  
5201/00N SELF-CLOSING



- B** Kit cojnete grande con ruedita  
- carro  
- ruedita  
- cojnete grande
- C** Frenos tipo cubo
- D** Kit bufer  
- bufer  
- cojnete pequeño
- E** Frenos tipo bufer
- F** Kit cojnete pequeño con ruedita  
- carro  
- ruedita  
- cojnete pequeño
- G** Kit cojnete pequeño sin ruedita  
- carro  
- cojnete pequeño
- H** Sujeta correa en techo
- I** Sujeta correa en cojnete
- J** Correa
- K** Pinza de correa
- L** Gulador en puerta
- M** Gulador en suelo

BLANCO BLANC WHITE BIANCO	NEGRO NOIR BLACK NERO	BRUTO BRUT RAW GREZZO	COLOR COULEUR COLOR COLORE	
OB	ON	OO	OP	
		Al	4 m	€/u
<input type="radio"/>	<input type="radio"/>	<input type="radio"/>	<input type="radio"/>	
		Al	4 m	€/u
<input type="radio"/>	<input type="radio"/>	<input type="radio"/>	<input type="radio"/>	
				€/u
<input type="radio"/>	<input type="radio"/>	<input type="radio"/>	<input type="radio"/>	

# PUERTAS DE PASO - MARCO TELEX 3

## MARCOS

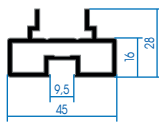

PERFIL INFERIOR Y SUPERIOR (MARCO)  
PROFIL DE CADRE SUPÉRIEUR  
ET INFÉRIEUR  
UPPER AND BOTTOM  
FRAME PROFILE  
PROFILO SUPERIORE E  
INFERIORE CORNICE  
5205/20.

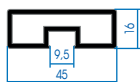
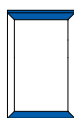

PERFIL LATERAL (MARCO)  
PROFIL DE CADRE LATÉRAL  
LATERAL FRAME PROFILE  
PROFILO LATERALE CORNICE  
5206/30.



ESCUADRA UNIÓN PERFILES  
SUPPORT POUR ASSEMBLER DES  
PROFILS  
BRACKET FOR JOINING PROFILES  
GIUNTO UNIONE PROFILI  
5207/000



GALGA ESCUADRA /  
MECANIZACIÓN PERFIL  
JAUGE CARRÉE  
BRACKET GAUGE  
CALIBRO SQUADRA  
5207/010



KIT MARCO DE ALUMINIO 3X1M  
(1 PUERTA)  
KIT CADRE DE ALUMINIUM  
3X1M (1 PORTÉ)  
SET ALUMINIUM FRAME  
3X1M (1 FRAME)  
CONGIUNTO PERIMETRALE  
DI ALLUMINIO 3X1M  
5204/00. gancho hasta 95cm  
5204/01. ancho más de 95cm

BLANCO BLANC WHITE BIANCO	NEGRO NOIR BLACK NERO	BRUTO BRUT RAW GREZZO	COLOR COULEUR COLOR COLORE	
OB	ON	OO	OP	
		Al	2 m	€/u
<input type="radio"/>	<input type="radio"/>	<input type="radio"/>	<input type="radio"/>	
		Al	3 m	€/u
<input type="radio"/>	<input type="radio"/>	<input type="radio"/>	<input type="radio"/>	
		Al		€/u
<input type="radio"/>	<input type="radio"/>	<input type="radio"/>	<input type="radio"/>	
		Pla		€/u
<input type="radio"/>	<input type="radio"/>	<input type="radio"/>	<input type="radio"/>	
		Al	2 m	€/u
<input type="radio"/>	<input type="radio"/>	<input type="radio"/>	<input type="radio"/>	
<input type="radio"/>	<input type="radio"/>	<input type="radio"/>	<input type="radio"/>	

PLÁSTICO  
PLASTIQUE  
PLASTIC  
PLASTICA  
09



- N** Perfil inferior y superior (marco)
- O** Perfil lateral (marco)
- P** Escuadra unión perfiles
- Q** Cinta adhesiva vidrio

# PUERTAS DE PASO - MARCO TELEX 3

## ACCESORIOS

BLANCO BLANC WHITE BIANCO	NEGRO NOIR BLACK NERO	BRUTO BRUT RAW GREZZO	COLOR COULEUR COLOR COLORE
OB	ON	OO	OP



**TIRADOR DOBLE PARA MARCO DE ALUMINIO**  
POIGNÉE DOUBLE POUR CADRE EN ALUMINIUM  
DOUBLE HANDLE FOR ALUMINIUM FRAME  
MANIGLIA DOPPIA  
TELAIO IN ALLUMINIO  
5208/00.

Al	213x46x13mm	€/u
----	-------------	-----

○ ○ ○ ○



**TIRADOR DOBLE CON PESTILLO PICO DE LORO**  
DOUBLE POIGNÉE DE VERROUILLAGE  
DOUBLE HANDLE WITH LATCH  
MANIGLIA DOPPIA CON CHIAVISTELLO  
5216/00N

Al	213x46x13mm	€/u
----	-------------	-----

○



**CERRADURA DE PUERTA ENMARCADA CON LLAVE PICO DE LORO**  
SERRURE DE PORTE ENCADRÉE AVEC CLÉ  
FRAMED DOOR LOCK WITH KEY  
SERRATURA PER PORTE CON CORNICE CON CHIAVE  
5215/00N

Al	104x77x15mm	€/u
----	-------------	-----

○



**ANCLAJE PARA MARCO DE PUERTA FIJA**  
ANCRAGE DE CADRE DE PORTE FIXE  
FIXED DOOR FRAME ANCHOR  
ANCORAGGIO TELAIIO PORTA FISSO  
5203/000

lx	€/u
----	-----

○



**PERFIL ALUMINIO PARA CRISTAL-PUERTA DE PANEL JAPONÉS**  
PROFILÉ EN ALUMINIUM POUR LE VERRE DANS LA PORTE À PANNEAU JAPONAIS.  
ALUMINIUM PROFILE FOR GLASS IN JAPANESE PANEL DOOR.  
PROFILO IN ALLUMINIO PER VETRO IN ANTA A PANNELLO GIAPPONESE.  
5127/30.

Al	15,6x10,1mm	€/u
⊙ 5209	⊏ 3 m	

○ ○ ○ ○

Instrucciones de montaje en la página 15.



**PERFIL EMBELLECEDOR EN "L"**  
PROFILÉ DE FINITION "L"  
"L" FINISHING PROFILE  
PROFILO DI FINITURA A "L"  
5203/10.

Al	40x10x0,8mm	€/m
	⊏ 2 m	

○ ○ ○ ○

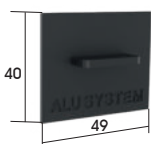

**TAPETA EMBELLECEDORA**  
PROFILÉ DE FINITION "L"  
"L" FINISHING PROFILE  
PROFILO DI FINITURA A "L"  
85205/00N

Pl	40x10x0,8mm	€/m
----	-------------	-----

○

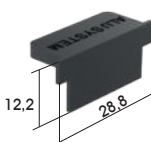

**TAPETA EMBELLECEDORA**  
PROFILÉ DE FINITION "L"  
"L" FINISHING PROFILE  
PROFILO DI FINITURA A "L"  
85203/00N

Pl	40x10x0,8mm	€/m
----	-------------	-----

○

# PUERTAS DE PASO - MARCO TELEX 3

## KIS PUERTA COMPLETA

BLANCO BLANC WHITE BIANCO	NEGRO NOIR BLACK NERO	BRUTO BRUT RAW GREZZO	COLOR COULEUR COLOR COLORE
OB	ON	OO	OP

**TELEX 3**  
3 puertas telescópicas



**ANCHO PUERTA HASTA 95**  
CARRIL 4M

**ANCHO PUERTA MÁS DE 95**  
CARRIL 4M

REF. 5213/00.

REF. 5213/01.

- X3 5111/40.
- X2 5210/40.
- X1 5201/00N
- X3 5204/00.
- X1 5208/00.

- X3 5111/40.
- X2 5210/40.
- X1 5201/00N
- X3 5204/01.
- X1 5208/00.

5213/00. ○ ○ ○ ○  
5213/01. ○ ○ ○ ○

**TELEX 3**  
1 fijo + 3 puertas telescópicas



**ANCHO PUERTA HASTA 95**  
CARRIL 4M

**ANCHO PUERTA MÁS DE 95**  
CARRIL 4M

REF. 5214/00.

REF. 5214/01.

- X4 5111/40.
- X2 5210/40.
- X1 5201/00N
- X4 5204/00.
- X1 5208/00.
- X1 5203/000T

- X4 5111/40.
- X2 5210/40.
- X1 5201/00N
- X4 5204/01.
- X1 5208/00.
- X1 5203/000

5214/00. ○ ○ ○ ○  
5214/01. ○ ○ ○ ○



**3M CINTA AUTOADHESIVA VIDRIO MAX. CALIDAD. TRANSPARENTE. PARA PERFILES PUERTA JAPONESA**  
RUBAN ADHÉSIF DOUBLE FACE EN VERRE  
GLASS DOUBLE SIDED TAPE  
NASTRO BIADESIVO VETRO  
5209/109  
5209/009 ROLLO DE 33M

Pla	€/m
-----	-----

PLÁSTICO  
PLASTIQUE  
PLASTIC  
PLASTICA  
09

○ ○

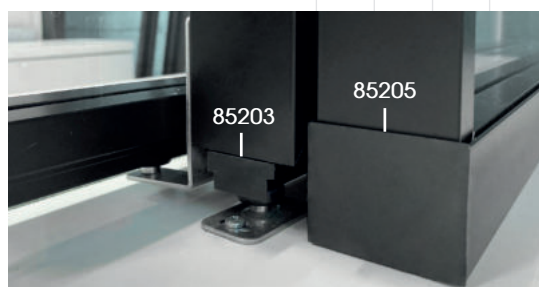

**COTEK - SERENA<sup>80KG</sup>**

PUERTAS CORREDERA - PORTES COULISSANTS  
SLIDING DOORS - PORTE SCORREVOLI

CR. BRILLO CH-R. POLI BR. CH-R CR. LUC	PL. M ALU. M ALU. M ALL. NAT	BRUTO BRUT RAW GREZZO	PLÁSTICO PLASTIQUE PLASTIC PLASTICA
32	01	00	09

**COTEK - SERENA<sup>80KG</sup>**

PUERTAS CORREDERA - PORTES COULISSANTS  
SLIDING DOORS - PORTE SCORREVOLI

CR. BRILLO CH-R. POLI BR. CH-R CR. LUC	PL. M ALU. M ALU. M ALL. NAT	BRUTO BRUT RAW GREZZO	PLÁSTICO PLASTIQUE PLASTIC PLASTICA
32	01	00	09

**SERENA**

- peso max. puerta: 80 kg/puerta
- vidrio 8-10-12 mm
- sin muesca en el vidrio

- pods-limite porte: 80 kg/porte
- verre 8-10-12 mm
- sans encoches
- weight max. door: 80 kg/door
- glass 8-10-12 mm
- without cut-out
- peso max. porta: 80 kg/porta
- vetro 8-10-12 mm
- senza tacca nel vetro

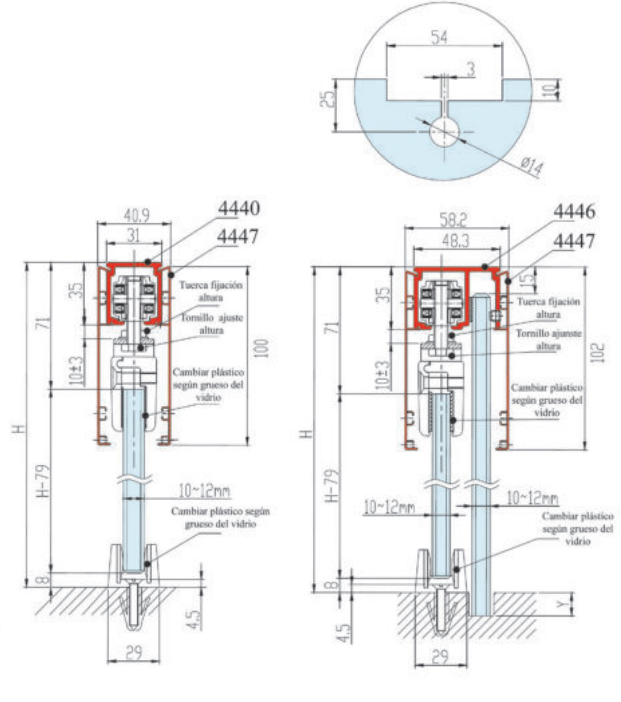
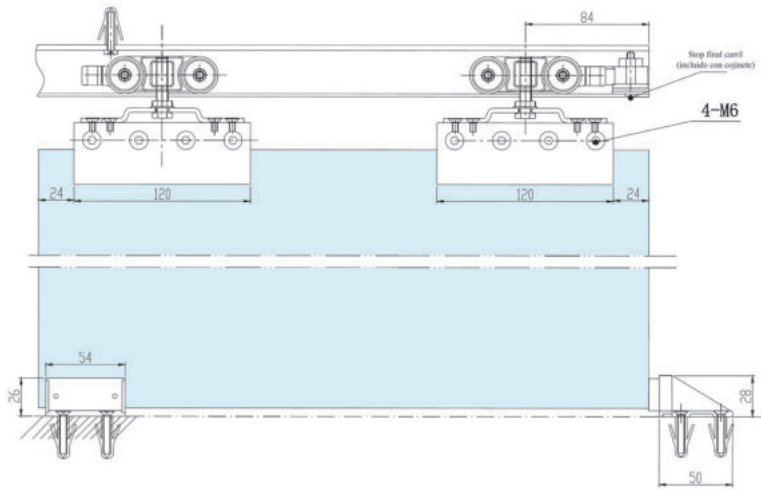

**CARRIL  
COULISSE HAUTE  
UPPER TRACK  
GUIDA SUPERIORE**  
4445/201 1,93 m  
4445/301 2,90 m  
4445/501 5,80 m

Al	5,8m	31x35	€/u
		○	
		○	
		○	



**CARRIL + VIDRIO FIJO  
COULISSE HAUTE + VERRE FIXE  
UPPER TRACK + FIXED GLASS  
GUIDA SUP + VETRO FISSO**  
4446/201 1,93 m  
4446/301 2,90 m  
4446/501 5,80 m

Al	5,8m	48x35	€/u
	8-12 mm		
		○	
		○	
		○	



**PERFIL TAPA CARRIL  
PROFIL COUVERTURE COULISSE  
TRACK COVER PROFIL  
PROFILO COPERTINA GUIDA**  
4447/201 1,93 m  
4447/301 2,90 m  
4447/501 5,80 m

Al	5,8m	100x7	€/u
		∞ 4445 - 4446 - 4440	
		○	
		○	
		○	



**KIT PINZA PORTAVIDRIO  
ALUMINIO  
KIT PINCE POUR VERRE  
CLAMP FOR GLASS KIT  
KIT PINZA PER VETRO**

4440/011  
Pinzas 2 u.  
Guía Inferior 1 u.

Al	inox s.s.	120x45	€/u
		80 kg/2u. 8-10-12 mm	
		○	



**PERFIL TAPA CARRIL  
PROFIL COUVERTURE COULISSE  
TRACK COVER PROFIL  
PROFILO COPERTINA GUIDA**  
4448/101

Al	3 m	48x7	€/m
		∞ 4445 - 4446 - 4441	
		○	



**KIT PINZA PORTAVIDRIO  
ALUMINIO  
KIT PINCE POUR VERRE  
CLAMP FOR GLASS KIT  
KIT PINZA PER VETRO**

4441/011  
Pinzas 2 u.  
Guía Inferior 1 u.

Al	inox s.s.	120x45	€/u
		80 kg/2u. 8-10 mm	
		○	



**GUÍA SUELO  
GUIDAGE AU SOL  
FLOOR GUIDE  
GUIDA A PAVIMENTO**  
4442/001

Al	plas		€/u
		○	



**FIJACIÓN FRONTAL DEL CARRIL  
FIXATION FRONT COULISSE  
ASSEMBLY FITTING FOR TRACK  
AGGANCIO FRONTALE GUIDA**  
4443/001

Al		€/u
	○	



**REMATE FINAL CARRIL- GRIS  
BOUCHON COULISSE- GRIS  
END-CAP TRACK-GRAY  
COPRITESTA TUBO - GRIGIO**  
4444/009

plas	∞ 4445	€/u
		○



**REMATE FINAL CARRIL- GRIS  
BOUCHON COULISSE- GRIS  
END-CAP TRACK-GRAY  
COPRITESTA TUBO - GRIGIO**  
4454/009

plas	∞ 4448	€/u
		○



**UÑERO DOBLE ADHESIVO  
POIGNÉE DOUBLE ADHESIVE  
DOUBLE ADHESIVE PULL  
POMO DOPPIO ADHESIVO**  
4207/0..  
4207/0..

∅ 60		€/u
	○	
	○	



**GALGA MONTAJE UÑEROS  
GABARIT DE MONTAGE  
INSTALLATION TOOL  
SAGOMA AIUTO MONTAGGIO**  
4209/000

Al		€/u
	○	



**POMO  
POIGNÉE  
KNOB  
POMO**  
4223/0..

Al	100	€/u
	8-10 mm	
	○	
	○	



## COTEK - SERENA 80 KG

PUERTAS CORREDERA - PORTES COULISSANTS  
SLIDING DOORS - PORTE SCORREVOLI

### SERENA - KIT PUERTA CORREDERA

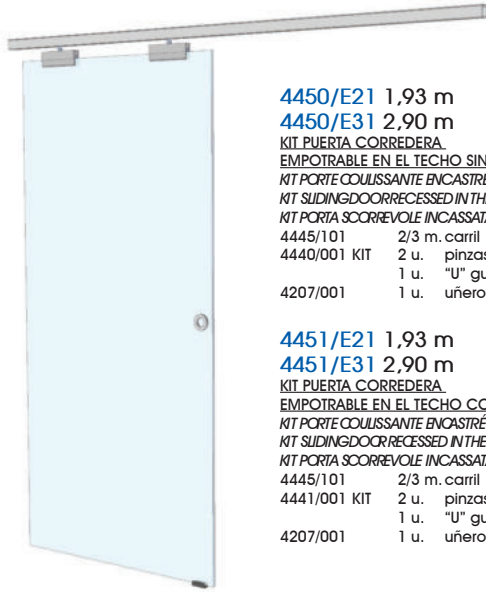

**4450/E21** 1,93 m  
**4450/E31** 2,90 m  
KIT PUERTA CORREDERA  
EMPOTRABLE EN EL TECHO SIN MUESCA  
KIT PORTE COULISSANTE ENCASTRÉ AU PLAFOND  
KIT SLIDING DOOR RECESSED IN THE CEILING  
KIT PORTA SCORREVOLE INCASSATA NEL SOFFITTO  
4445/101 2/3 m. carril  
4440/001 KIT 2 u. pinzas  
1 u. "U" guía inferior  
4207/001 1 u. uñero

**4451/E21** 1,93 m  
**4451/E31** 2,90 m  
KIT PUERTA CORREDERA  
EMPOTRABLE EN EL TECHO CON MUESCA  
KIT PORTE COULISSANTE ENCASTRÉ AU PLAFOND  
KIT SLIDING DOOR RECESSED IN THE CEILING  
KIT PORTA SCORREVOLE INCASSATA NEL SOFFITTO  
4445/101 2/3 m. carril  
4441/001 KIT 2 u. pinzas  
1 u. "U" guía inferior  
4207/001 1 u. uñero

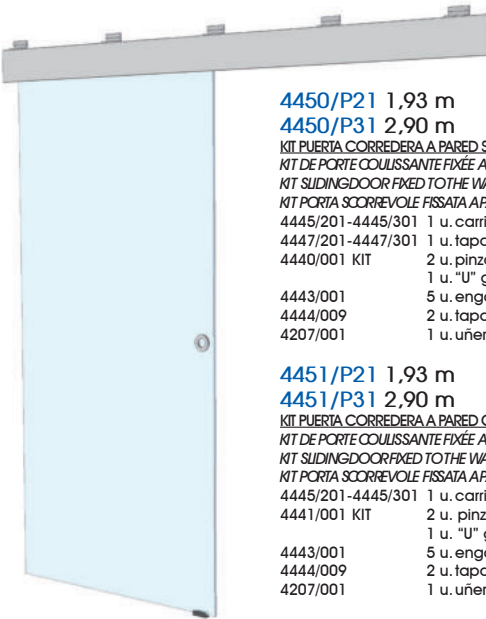

**4450/P21** 1,93 m  
**4450/P31** 2,90 m  
KIT PUERTA CORREDERA A PARED SIN MUESCA  
KIT DE PORTE COULISSANTE FIXÉE AU MUR  
KIT SLIDING DOOR FIXED TO THE WALL  
KIT PORTA SCORREVOLE FISSATA A PARETE  
4445/201-4445/301 1 u. carril  
4447/201-4447/301 1 u. tapa carril  
4440/001 KIT 2 u. pinzas  
1 u. "U" guía inferior  
4443/001 5 u. engancho pared  
4444/009 2 u. tapa lateral  
4207/001 1 u. uñero

**4451/P21** 1,93 m  
**4451/P31** 2,90 m  
KIT PUERTA CORREDERA A PARED CON MUESCA  
KIT DE PORTE COULISSANTE FIXÉE AU MUR  
KIT SLIDING DOOR FIXED TO THE WALL  
KIT PORTA SCORREVOLE FISSATA A PARETE  
4445/201-4445/301 1 u. carril  
4441/001 KIT 2 u. pinzas  
1 u. "U" guía inferior  
4443/001 5 u. engancho pared  
4444/009 2 u. tapa lateral  
4207/001 1 u. uñero

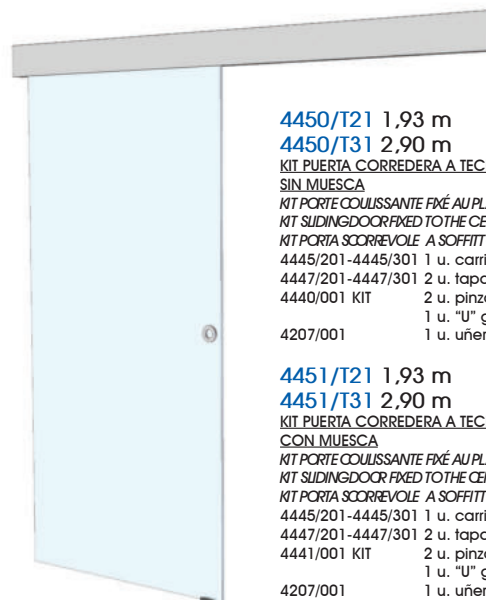

**4450/T21** 1,93 m  
**4450/T31** 2,90 m  
KIT PUERTA CORREDERA A TECHO SIN MUESCA  
KIT PORTE COULISSANTE FIXÉ AU PLAFOND  
KIT SLIDING DOOR FIXED TO THE CEILING  
KIT PORTA SCORREVOLE A SOFFITTO  
4445/201-4445/301 1 u. carril  
4447/201-4447/301 2 u. tapa carril  
4440/001 KIT 2 u. pinzas  
1 u. "U" guía inferior  
4207/001 1 u. uñero

**4451/T21** 1,93 m  
**4451/T31** 2,90 m  
KIT PUERTA CORREDERA A TECHO CON MUESCA  
KIT PORTE COULISSANTE FIXÉ AU PLAFOND  
KIT SLIDING DOOR FIXED TO THE CEILING  
KIT PORTA SCORREVOLE A SOFFITTO  
4445/201-4445/301 1 u. carril  
4447/201-4447/301 2 u. tapa carril  
4441/001 KIT 2 u. pinzas  
1 u. "U" guía inferior  
4207/001 1 u. uñero

PLATA MATE  
ALU. MAT  
ALU. MATT  
ALL. NATURALE  
01

○ €/u

○ €/u

○ €/u

○ €/u

○ €/u

○ €/u

## COTEK - SERENA 80 KG

PUERTAS CORREDERA - PORTES COULISSANTS  
SLIDING DOORS - PORTE SCORREVOLI

### SERENA - KIT PUERTA CORREDERA + FIJO

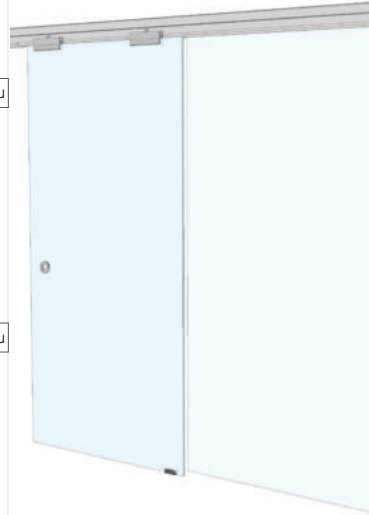

**4452/E21** 1,93 m  
**4452/E31** 2,90 m  
KIT PUERTA CORREDERA  
EMPOTRABLE A TECHO + VIDRIO FIJO SIN MUESCA  
KIT PORTE COULISSANTE ENCASTRÉ AU PLAFOND + VERRE FIXE  
KIT SLIDING DOOR RECESSED IN THE CEILING + FIXED GLASS  
KIT PORTA SCORREVOLE INCASSATA NEL SOFFITTO + VETRO FISSO  
4446/201-4446/301 1 u. carril  
4440/001 KIT 2 u. pinzas  
1 u. "U" guía inferior  
4207/001 1 u. uñero

**4453/E21** 1,93 m  
**4453/E31** 2,90 m  
KIT PUERTA CORREDERA  
EMPOTRABLE A TECHO + VIDRIO FIJO CON MUESCA  
KIT PORTE COULISSANTE ENCASTRÉ AU PLAFOND + VERRE FIXE  
KIT SLIDING DOOR RECESSED IN THE CEILING + FIXED GLASS  
KIT PORTA SCORREVOLE INCASSATA NEL SOFFITTO + VETRO FISSO  
4446/201-4446/301 1 u. carril  
4441/001 KIT 2 u. pinzas  
1 u. "U" guía inferior  
4207/001 1 u. uñero

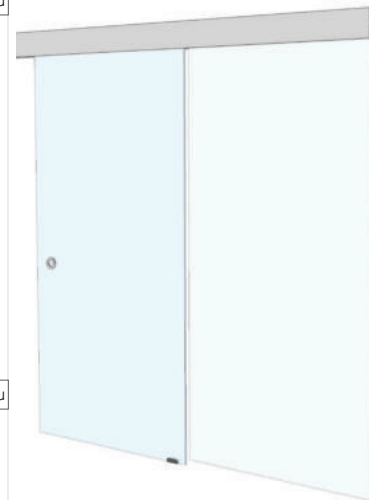

**4452/T21** 1,93 m  
**4452/T31** 2,90 m  
KIT PUERTA CORREDERA A TECHO + VIDRIO FIJO SIN MUESCA  
KIT PORTE COULISSANTE FIXÉ AU PLAFOND + VERRE FIXE  
KIT SLIDING DOOR FIXED TO THE CEILING + FIXED GLASS  
KIT PORTA SCORREVOLE A SOFFITTO + VETRO FISSO  
4446/201-4446/301 1 u. carril  
4447/201-4447/301 2 u. tapa carril  
4440/001 KIT 2 u. pinzas  
1 u. "U" guía inferior  
4207/001 1 u. uñero

**4453/T21** 1,93 m  
**4453/T31** 2,90 m  
KIT PUERTA CORREDERA A TECHO + VIDRIO FIJO CON MUESCA  
KIT PORTE COULISSANTE FIXÉ AU PLAFOND + VERRE FIXE  
KIT SLIDING DOOR FIXED TO THE CEILING + FIXED GLASS  
KIT PORTA SCORREVOLE A SOFFITTO + VETRO FISSO  
4446/201-4446/301 1 u. carril  
4447/201-4447/301 2 u. tapa carril  
4441/001 KIT 2 u. pinzas  
1 u. "U" guía inferior  
4207/001 1 u. uñero

PLATA MATE  
ALU. MAT  
ALU. MATT  
ALL. NATURALE  
01

○ €/u

○ €/u

○ €/u

○ €/u

# COTEK - SYNCRO 80KG

PUERTAS CORREDERA - PORTES COULISSANTS  
SLIDING DOORS - PORTE SCORREVOLI

## SYNCRO

- peso max. puerta: 80 kg/puerta
- vidrio 8-12 mm
- sin muesca en el vidrio
- 2 puertas sincronizadas

- pods-limite porte: 80 kg/porte
- verre 8-12 mm
- sans encoches
- 2 portes synchronisées
- weight max. door: 80 kg/door
- glass 8-12 mm
- without cut-out
- 2 synchronized doors
- peso max. porta: 80 kg/porta
- vetro 8-12 mm
- senza tacca nel vetro
- 2 porte sincronizzate

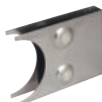
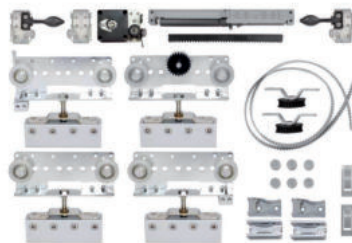
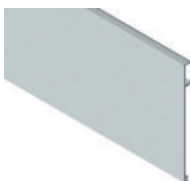
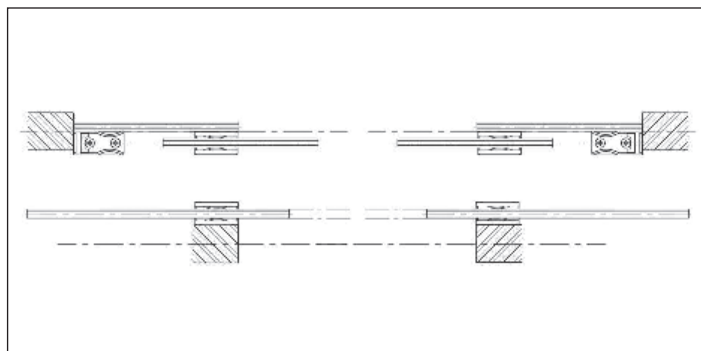
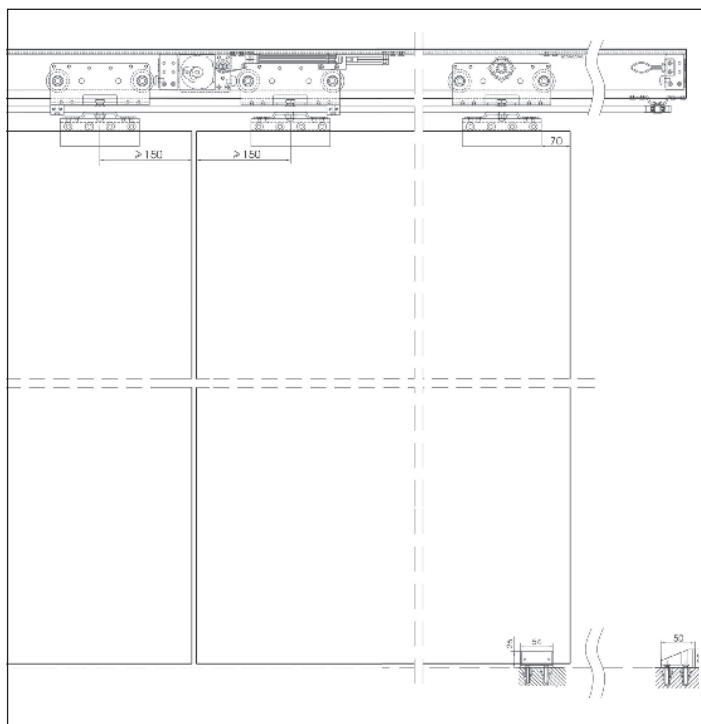
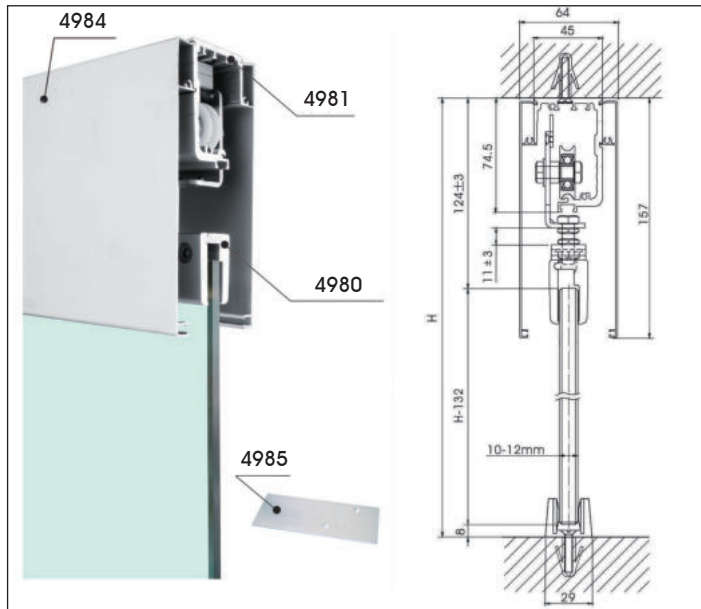

CARRIL  
COULISSE HAUTE  
UPPER TRACK  
GUIDA SUPERIORE  
**4981/401**

PERFIL SUPERIORVIDRIO FIJO  
PROFIL SUPERIEUR VERRE FIXE  
UPPE PROFILE FIXED GLASS  
PROFILO ISUPERIORE VETROFISSO  
**4982/401**

PERFIL SOPORTE A PARED  
DE VIDRIO + ANCLAJES  
PROFIL SUPPORT MUR DE  
VERRE + ANCRÉS  
PROFILE WALL-GLASS SUPPORT  
+ ANCHORS  
PROFILO SUPPORTO APARETE  
DI VETRO + ANCORAGG  
**4983/401**

PERFIL TAPA CARRIL  
PROFIL COUVERTURE COULISSE  
TRACK COVER PROFIL  
PROFILO COPERTINA GUIDA  
**\*4984/401**

REMATE FINAL CARRIL- GRIS  
BOUCHON COULISSE- GRIS  
END-CAP TRACK-GRAY  
COPRITESTA TUBO - GRIGIO  
**4985/009**

KIT PINZAS 2 PUERTAS  
SINCRONIZADAS  
KIT 2 PINCES 2 PORTES  
SYNCRONIZÉE  
KIT CLAMPS 2 SYNCONIZED  
DOORS  
KIT PINZE PER 2 PORTE  
SINCRONIZZATE  
**4980/001**

UNERO DOBLE ADHESIVO  
POIGNÉE DOUBLE ADHESIVE  
DOUBLE ADHESIVE PULL  
POMO DOPPIO ADHESIVO  
**4207/0..**  
**4207/0..**

GALGA MONTAJE UNEROS  
GABARIT DE MONTAGE  
INSTALLATION TOOL  
SAGOMA AIUTO MONTAGGIO  
**4209/000**

POMO  
POIGNÉE  
KNOB  
POMO  
**4223/0..**

CR. BRILLO	PL. M	BRUTO	PLÁSTICO
CH. POLI	ALU. M	BRUT	PLASTIQU E
BR. CH	ALU. M	RAW	PLASTI C
CR. LUC	ALL. NAT	GREZZO	PLASTICA
32	01	00	09
Al	4 m	74,5x45	€/u
			o
Al	4 m	∞ 4981-4984	€/u
	8-12 mm		o
Al	4 m		€/u
			o
Al	4 m	157x10	€/u
		∞ 4981-4982	o
plas	157x55	∞ 4981- 4984	€/u
			o
Al	80kg/2u.	120x45	€/u
			o
			INOX BR INOX POLI P.S.S. NOX LUC
			INOX SAT INOX SAT S.S.S. NOX SAT
			22 28
	∅ 60		€/u
Al			€/u
			o
Al			€/u
			o
Al	100		€/u
	8-10 mm		o
			o

**COTEK - SYNCRO 80 KG**  
PUERTAS CORREDERA SINCRONIZADAS - PORTES COULISSANTES SYNCHRONISÉES  
SYNCRONIZED SLIDING DOORS - PORTE SCORREVOLI SINCRONIZZATE

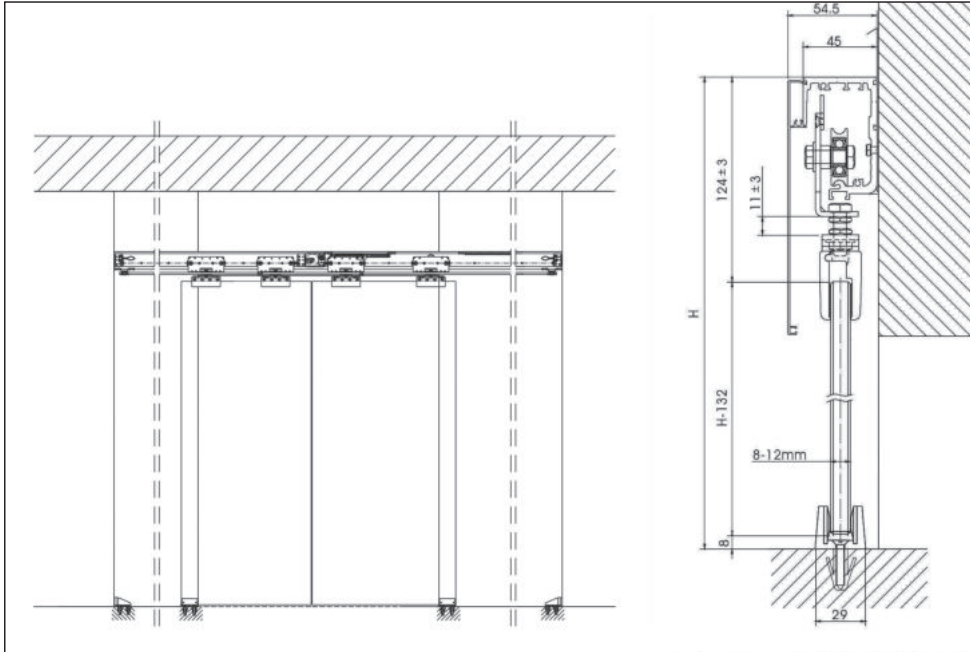

**MONTAJE A PARED**

**4986/001**

KIT PUERTA CORREDERA A PARED  
KIT DE PORTE COULISSANTE FIXÉE AU MUR  
KIT SLIDING DOOR FIXED TO THE WALL  
KIT PORTA SCORREVOLI FISSATA A PARETE

€/U

- 4981/401 1 u. carril 4 m
- 4984/401 1 u. tapa frontal 4 m
- 4980/001 1 u. kit pinzas
- 4985/001 2 u. tapa final
- 4207/001 2 u. uñero

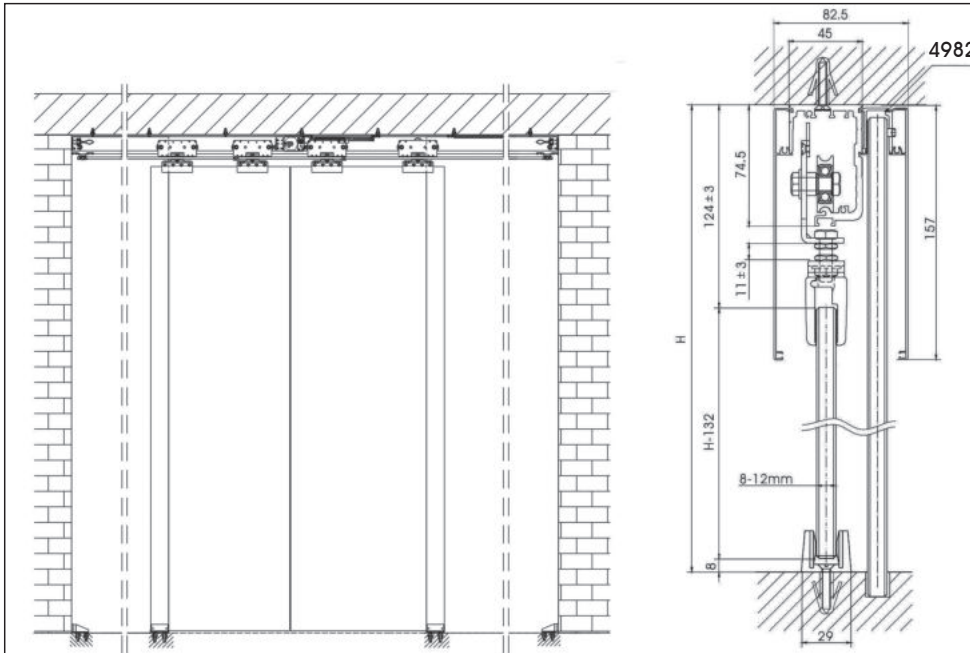

**MONTAJE A TECHO**

**4987/001**

KIT PUERTA CORREDERA A TECHO  
KIT PORTE COULISSANTE FIXÉE AU PLAFOND  
KIT SLIDING DOOR FIXED TO THE CEILING  
KIT PORTA SCORREVOLI A SOFFITTO

€/U

- 4981/401 1 u. carril 4 m
- 4982/401 1 u. perfil superior vidrio fijo 4 m
- 4984/401 2 u. tapa frontal 4 m
- 4980/001 1 u. kit pinzas
- 4207/001 2 u. uñero

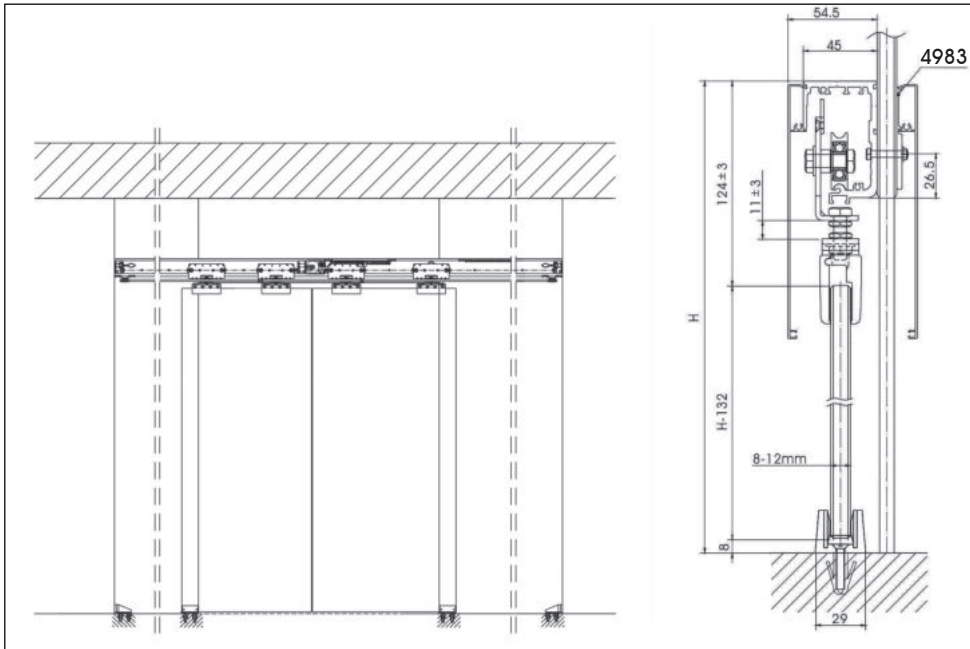

**MONTAJE A VIDRIO FIJO**

**4988/001**

KIT PUERTA CORREDERA A VIDRIO FIJO  
KIT DE PORTE COULISSANTE FIXÉE AU MUR DE VERRE  
KIT SLIDING DOOR FIXED TO THE GLASS-WALL  
KIT PORTA SCORREVOLI FISSATA A PARETE DI VETRO

€/U

- 4981/401 1 u. carril 4 m
- 4983/401 4 u. perfil soporte vidrio fijo 4 m
- 4984/401 2 u. tapa frontal 4 m
- 4980/001 1 u. kit pinzas
- 4985/001 2 u. tapa final
- 4207/001 2 u. uñero

# COTEK - TELEX 80 KG

PUERTAS CORREDERA TELESCÓPICAS - PORTES COULISSANTES TÉLESCOPIQUES  
TELESCOPIC SLIDING DOORS - PORTE SCORREVOLI TELESCOPICHE

CR. BRILLO CHR. POLI BR. CHR. CR. LUC	PL. M ALU. M ALU. M ALL. NAT	BRUTO BRUT RAW GREZZO	PLÁSTICO PLASTIQUE PLASTIC PLASTICA
32	01	00	09

## TELEX 2

- peso max. puerta: 80 kg/puerta
- vidrio 8-12 mm
- sin muesca en el vidrio
- 1 fijo + 2 correderas

- pods-limite porte: 80 kg/porte
- verre 8-12 mm
- sans encoches
- 1 verre fixe + 2 portes coulissantes
- weight max. door: 80 kg/door
- glass 8-12 mm
- without cut-out
- 1 fixed glass + 2 sliding doors
- peso max. porta: 80 kg/porta
- vetro 8-12 mm
- senza tacca nel vetro
- 1 vetro fisso + 2 porte scorrevoli

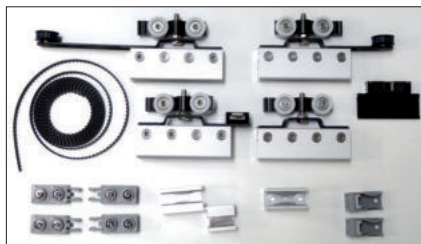

**KIT PUERTA TELESCÓPICA 3 m 2 CORREDERAS**  
2 PERFILES DE ALUMINIO + ACCESORIOS PARA  
2 PUERTAS TELESCÓPICAS

**SET PORTE TÉLESCOPIQUE 3 m 2 PORTES COULISSANTES**  
2 ALUMINIUM PERFILES + ACCESSOIRES POUR  
2 PORTES TÉLESCOPIQUES

**SET TELESCOPIC DOOR 3 m 2 SLIDING DOORS**  
2 ALUMINIUM PROFILES 3 m + ACCESSORIES FOR  
2 TELESCOPIC DOORS

**SET PORTE TELESCOPICHE 3 m 2 PORTES SCORREVOLI**  
2 PROFILI DI ALLUMINIO + ACCESSORI PER  
2 PORTE TELESCOPICHE

**4990/001 KIT BASE**  
KIT PORTE COULISSANTE  
KIT SLIDING DOOR  
KIT PORTA SCORREVOLE



**PERFIL SUPERIOR VIDRIO FIJO**  
PROFIL SUPERIEUR VERRE FIXE  
UPPE PROFILE FIXED GLASS  
PROFILO ISUPERIORE VETRO FISSO  
**4982/401**



**PERFIL TAPA CARRIL**  
PROFIL COUVERTURE COULISSE  
TRACK COVER PROFIL  
PROFILO COPERTINA GUIDA  
**\*4984/401**



**UÑERO DOBLE ADHESIVO**  
POIGNÉE DOUBLE ADHESIVE  
DOUBLE ADHESIVE PULL  
POMO DOPPIO ADHESIVO  
**4207/0..**  
**4207/0..**



**GALGA MONTAJE UÑEROS**  
GABARIT DE MONTAGE  
INSTALLATION TOOL  
SAGOMA AIUTO MONTAGGIO  
**4209/000**



**POMO**  
POIGNÉE  
KNOB  
POMO  
**4223/0..**

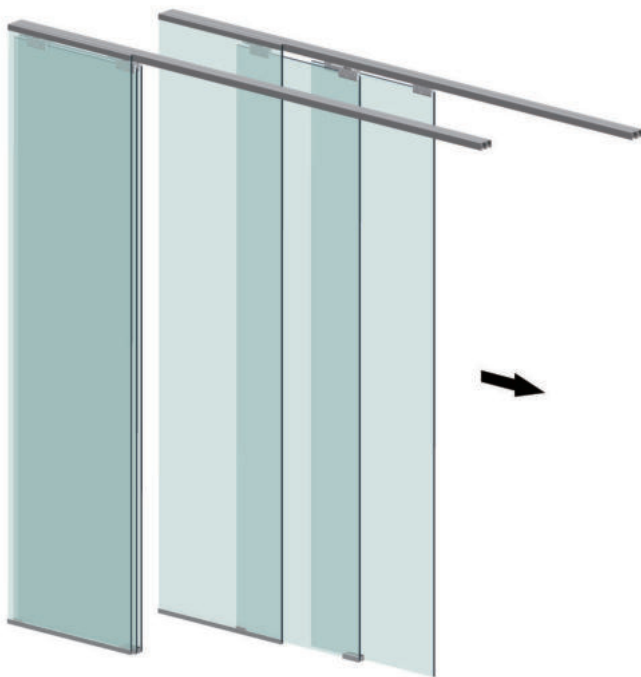

Al		3 m	∞	4983-4994	€/U
----	--	-----	---	-----------	-----

Al		4 m	∞	4990-4984	€/U
		8-12 mm			

Al		4 m	157x10		€/U
			∞	4983-4900	

		∅ 60			€/U
--	--	------	--	--	-----

Al					
inox					
s.s.					

Al					€/U
----	--	--	--	--	-----

Al		100			€/U
		8-10 mm			

INOX BR	INOX SAT
INOX POLI	INOX SAT
P.S.S.	S.S.S.
INOX LUC	INOX SAT
22	28

# COTEK - TELEX 80 KG

PUERTAS CORREDERA TELESCÓPICAS - PORTES COULISSANTES TÉLESCOPIQUES  
TELESCOPIC SLIDING DOORS - PORTE SCORREVOLI TELESCOPICHE

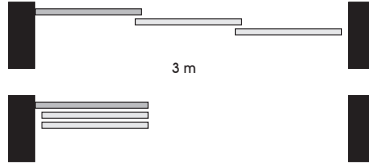
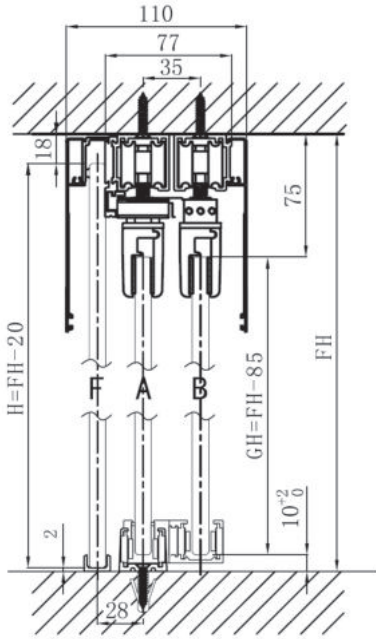

SET PUERTA TELESCÓPICA 3 m 1 FIJO + 2 CORREDERAS.  
PERFILES DE ALUMINIO + ACCESORIOS PARA 2 PUERTAS TELESCÓPICAS  
SET PORTE TÉLESCOPIQUE 3 m 1 FIXE + 2 PORTES COULISSANTES  
ALUMINIUM PERFILES + ACCESSOIRES POUR 2 PORTES TÉLESCOPIQUES  
SET TELESCOPIC DOOR 3 m 1 FIXED + 2 SLIDING DOORS  
ALUMINIUM PROFILS 3 m + ACCESSORIES FOR 2 TELESCOPIC DOORS  
SET PORTE TELESCOPICHE 3 m 1 FISSO + 2 PORTES SCORREVOLI  
PROFILI DI ALLUMINIO + ACCESSORI PER 2 PORTE TELESCOPICHE

4990/T01 KIT 4990 + 4982 + 2 TAPAS LATERALES 4984  
KIT PORTE COULISSANTE + 2 PROFILES COUVERTURE COULISSE 4982  
KIT SLIDINGDOOR + TRACK COVER PROFIL 4982  
KIT PORTASCORREVOLE + PROFILO COPERTINA GUIDA 4982

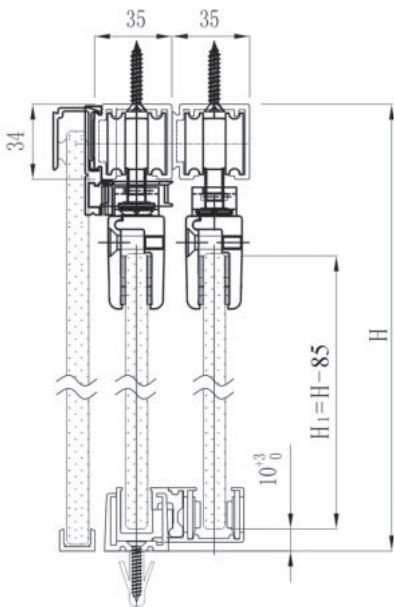
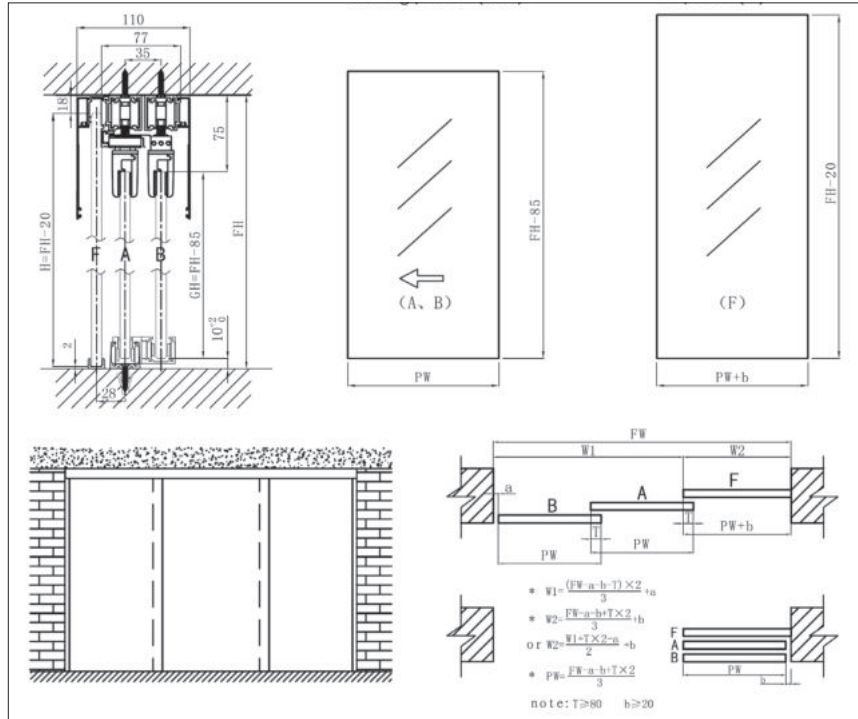

SET PUERTA TELESCÓPICA 3 m 1 FIJO + 2 CORREDERAS.  
PERFILES DE ALUMINIO + ACCESORIOS PARA 2 PUERTAS TELESCÓPICAS  
SET PORTE TÉLESCOPIQUE 3 m 1 FIXE + 2 PORTES COULISSANTES  
ALUMINIUM PERFILES + ACCESSOIRES POUR 2 PORTES TÉLESCOPIQUES  
SET TELESCOPIC DOOR 3 m 1 FIXED + 2 SLIDING DOORS  
ALUMINIUM PROFILS 3 m + ACCESSORIES FOR 2 TELESCOPIC DOORS  
SET PORTE TELESCOPICHE 3 m 1 FISSO + 2 PORTES SCORREVOLI  
PROFILI DI ALLUMINIO + ACCESSORI PER 2 PORTE TELESCOPICHE

4990/E01 KIT 4990 + 4982 EMPOTRADO EN EL TECHO  
KIT PORTE COULISSANTE ENCASTRÉ AU PLAFOND  
KIT SLIDINGDOOR RECESSED IN THE CEILING  
KIT PORTASCORREVOLE INCASSATA NEL SOFFITTO

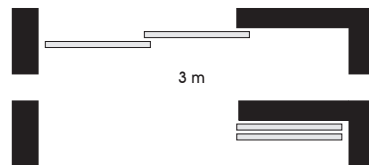
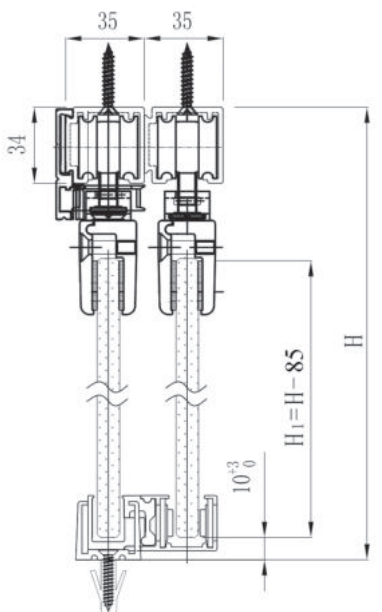

SET PUERTA TELESCÓPICA 3 m 2 CORREDERAS  
2 PERFILES DE ALUMINIO + ACCESORIOS PARA 2 PUERTAS TELESCÓPICAS  
SET PORTE TÉLESCOPIQUE 3 m 2 PORTES COULISSANTES  
2 ALUMINIUM PERFILES + ACCESSOIRES POUR 2 PORTES TÉLESCOPIQUES  
SET TELESCOPIC DOOR 3 m 2 SLIDING DOORS  
2 ALUMINIUM PROFILS 3 m + ACCESSORIES FOR 2 TELESCOPIC DOORS  
SET PORTE TELESCOPICHE 3 m 2 PORTES SCORREVOLI  
2 PROFILI DI ALLUMINIO + ACCESSORI PER 2 PORTE TELESCOPICHE

4990/001 KIT BASE

# COTEK - TELEX 80 KG

PUERTAS CORREDERA TELESCÓPICAS - PORTES COULISSANTES TÉLESCOPIQUES  
TELESCOPIC SLIDING DOORS - PORTE SCORREVOLI TELESCOPICHE

## TELEX 3

- peso max. puerta: 80 kg/puerta
- vidrio 8-12 mm
- sin muesca en el vidrio
- 1 fijo + 3 correderas

- pods-limite porte: 80 kg/porte
- verre 8-12 mm
- sans encoches
- 1 verre fixe + 3 portes coulissantes
- weight max. door: 80 kg/door
- glass 8-12 mm
- without cut-out
- 1 fixed glass+ 3 sliding doors
- peso max. porta: 80 kg/porta
- vetro 8-12 mm
- senza tacca nel vetro
- 1 vetro fisso + 3 porte scorrevoli

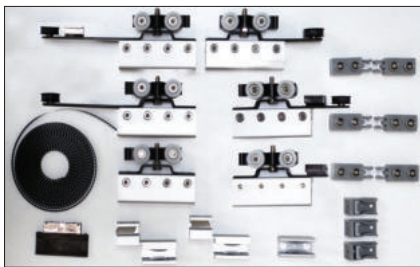

**KIT PUERTA TELESCÓPICA 4 m 3 CORREDERAS**  
3 PERFILES DE ALUMINIO + ACCESORIOS PARA  
3 PUERTAS TELESCÓPICAS

**SET PORTE TÉLESCOPIQUE 4 m 3 PORTES COULISSANTES**  
3 ALUMINIUM PERFILES + ACCESSOIRES POUR  
3 PORTES TÉLESCOPIQUES

**SET TELESCOPIC DOOR 4 m 3 SLIDING DOORS**  
3 ALUMINIUM PROFILES 3 m + ACCESSORIES FOR  
3 TELESCOPIC DOORS

**SET PORTE TELESCOPICHE 4 m 3 PORTES SCORREVOLI**  
3 PROFILI DI ALUMINIO + ACCESSORI PER  
3 PORTE TELESCOPICHE

**4991/001 KIT BASE**  
KIT PORTE COULISSANTE  
KIT SLIDINGDOOR  
KIT PORTA SCORREVOLE

**PERFIL SUPERIORVIDRIO FIJO**  
PROFIL SUPERIEUR VERRE FIXE  
UPPE PROFILE FIXED GLASS  
PROFILO ISUPERIORE VETRO FISSO  
**4982/401**

**PERFIL TAPA CARRIL**  
PROFIL COUVERTURE COULISSE  
TRACK COVER PROFIL  
PROFILO COPERTINA GUIDA  
**\*4984/401**

**UÑERO DOBLE ADHESIVO**  
POIGNÉE DOUBLE ADHESIVE  
DOUBLE ADHESIVE PULL  
POMO DOPPIO ADHESIVO  
**4207/0..**  
**4207/0..**

**GALGA MONTAJE UÑEROS**  
GABARIT DE MONTAGE  
INSTALLATION TOOL  
SAGOMA AIUTO MONTAGGIO  
**4209/000**

**POMO**  
POIGNÉE  
KNOB  
POMO  
**4223/0..**

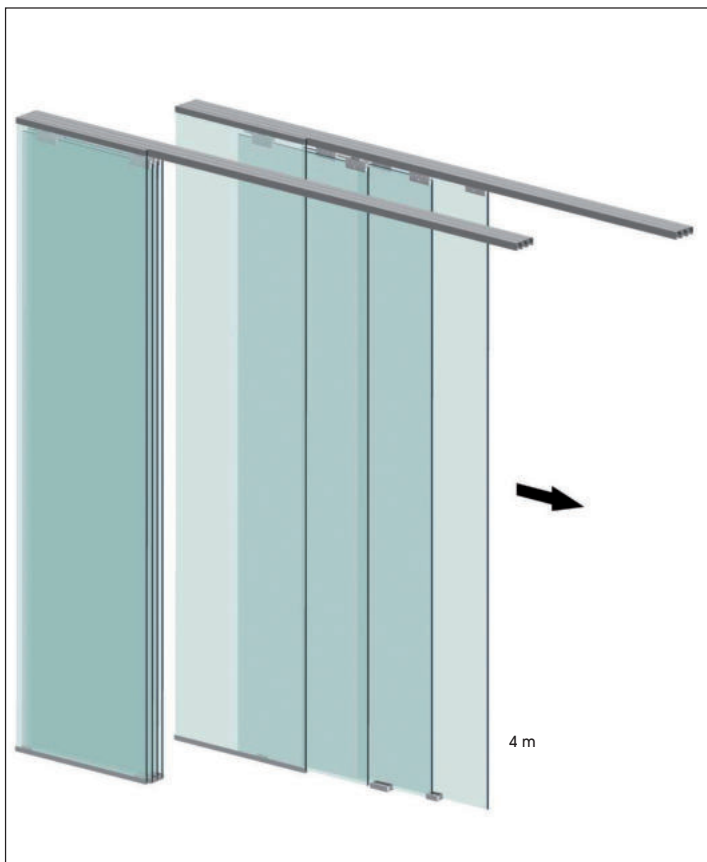

CR. BRILLO CR. POLI BR. CR. CR. LUC	PL. M ALU. M ALU. M ALL. NAT	BRUTO BRUT RAW GREZZO	PLÁSTICO PLASTIQUE PLASTIC PLASTICA
32	01	00	09

Al	4 m	∞	4983-4994	€/U
----	-----	---	-----------	-----

Al	4 m	∞	4990-4984	€/U
	8-12 mm			

Al	4 m	157x10		€/U
			∞	4983-4900

	∅ 60			€/U
--	------	--	--	-----

Al				€/U
----	--	--	--	-----

Al	100			€/U
	8-10 mm			

INOX BR INOX POLI P.S.S. INOX LUC	INOX SAT INOX SAT S.S.S. INOX SAT
22	28

# COTEK - TELEX 80 KG

PUERTAS CORREDERA TELESCÓPICAS - PORTES COULISSANTES TÉLESCOPIQUES  
TELESCOPIC SLIDING DOORS - PORTE SCORREVOLI TELESCOPICHE

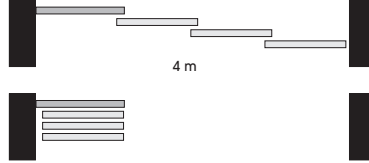
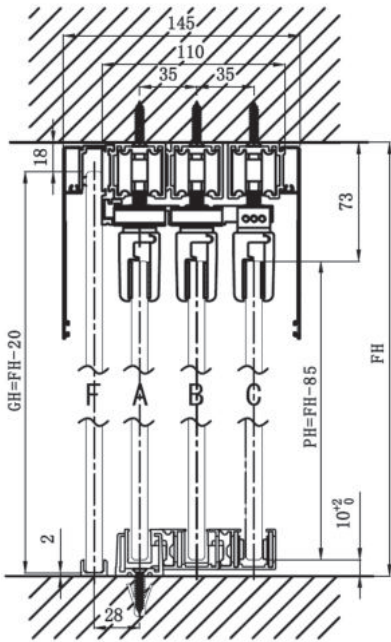

SET PUERTA TELESCÓPICA 4 m 1 FIJO + 3 CORREDERAS  
PERFILES DE ALUMINIO + ACCESORIOS PARA 3 PUERTAS TELESCÓPICAS  
SET PORTE TÉLESCOPIQUE 4 m 1 FIXE + 3 PORTES COULISSANTES  
ALUMINIUM PERFILES + ACCESSOIRES POUR 3 PORTES TÉLESCOPIQUES  
SET TELESCOPIC DOOR 4 m 1 FIXED + 3 SLIDING DOORS  
ALUMINIUM PROFILS + ACCESSORIES FOR 3 TELESCOPIC DOORS  
SET PORTE TELESCOPICHE 4 m 1 FISSO + 3 PORTES SCORREVOLI  
PROFILI DI ALLUMINIO + ACCESSORI PER 3 PORTE TELESCOPICHE

4991/T01 KIT 4991 + 4982 + 2 TAPAS LATERALES 4984  
KIT PORTE COULISSANTE + 2 PROFILES COUVERTURE COULISSE 4982  
KIT SLIDINGDOOR + TRACK COVER PROFIL 4982  
KIT PORTASCORREVOLE + PROFILO COPERTINA GUIDA 4982

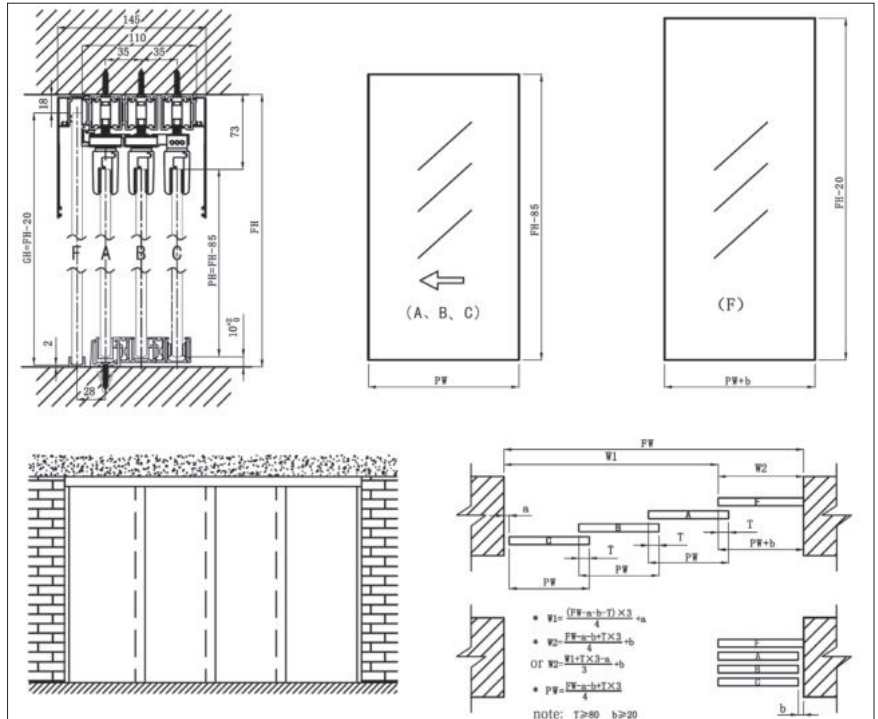

SET PUERTA TELESCÓPICA 4 m 1 FIJO + 3 CORREDERAS  
PERFILES DE ALUMINIO + ACCESORIOS PARA 3 PUERTAS TELESCÓPICAS  
SET PORTE TÉLESCOPIQUE 4 m 1 FIXE + 3 PORTES COULISSANTES  
ALUMINIUM PERFILES + ACCESSOIRES POUR 2 PORTES TÉLESCOPIQUES  
SET TELESCOPIC DOOR 4 m 1 FIXED + 3 SLIDING DOORS  
ALUMINIUM PROFILS + ACCESSORIES FOR 3 TELESCOPIC DOORS  
SET PORTE TELESCOPICHE 4 m 1 FISSO + 3 PORTES SCORREVOLI  
PROFILI DI ALLUMINIO + ACCESSORI PER 3 PORTE TELESCOPICHE

4991/E01 KIT 4991 + 4982 EMPOTRADO EN EL TECHO  
KIT PORTE COULISSANTE ENCASTRÉ AU PLAFOND  
KIT SLIDINGDOOR RECESSED IN THE CEILING  
KIT PORTASCORREVOLE INCASSATI NEL SOFFITTO

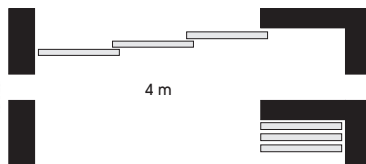
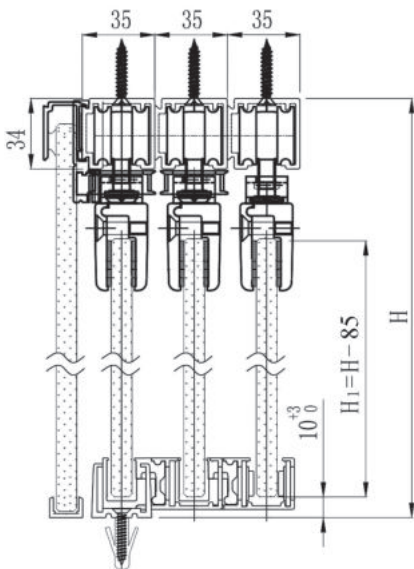

SET PUERTA TELESCÓPICA 4 m 3 CORREDERAS  
3 PERFILES DE ALUMINIO + ACCESORIOS PARA 3 PUERTAS TELESCÓPICAS  
SET PORTE TÉLESCOPIQUE 4 m 3 PORTES COULISSANTES  
3 ALUMINIUM PERFILES + ACCESSOIRES POUR 3 PORTES TÉLESCOPIQUES  
SET TELESCOPIC DOOR 4 m 3 SLIDING DOORS  
3 ALUMINIUM PROFILS 3 m + ACCESSORIES FOR 3 TELESCOPIC DOORS  
SET PORTE TELESCOPICHE 4 m 3 PORTES SCORREVOLI  
3 PROFILI DI ALLUMINIO + ACCESSORI PER 3 PORTE TELESCOPICHE

4991/001 KIT BASE

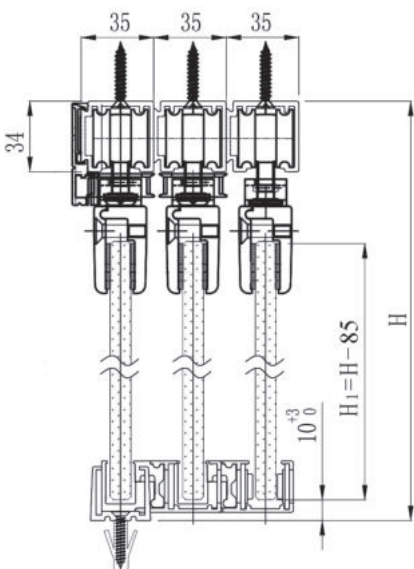



# COTEK - \*TOKYO 100 Kg

PUERTAS CORREDERA - PORTES COULISSANTES  
SLIDING DOORS - PORTE SCORREVOLI

## TOKYO

### PUERTA CORREDERA CON RELLAMADA AUTOMÁTICA

funciona como un cierrapuerta de suelo

Aluminio anodizado plata

Peso max: 100 kg/puerta

Vidrio: 8-12 mm

Largo max. 2 m

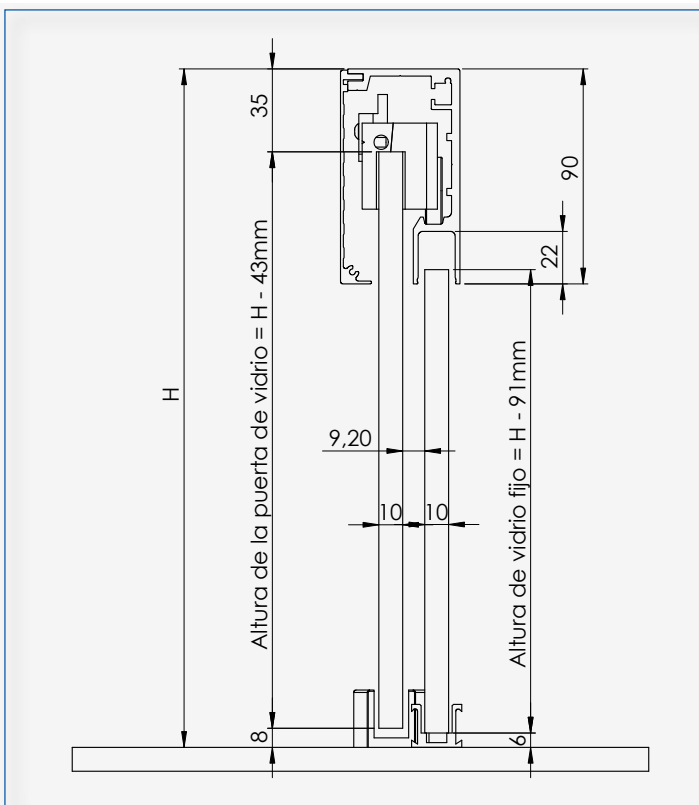

**CARRIL PARED + TAPA**  
COULISSE HAUTE + COUVERTURE  
UPPER TRACK + COVER PROFILE  
GUIDA SUPERIORE + COPERTINA  
**\*5910/201 2 m**

CR. BLOJO	PL. MATE	INOX. BR	INOX. SAT
CH. POLI	ANOD. M	INOX. POLI	INOX. SAT
BR. CHR	AN. CHR	P. S. S.	S. S. S.
CR. ILLC.	AN. OPAC	INOX. ILLC	INOX. SAT
<b>32</b>	<b>01</b>	<b>22</b>	<b>28</b>

Al	2 m	8-12 mm	€/u
----	-----	---------	-----

\*o



**CARRIL TECHO + TAPA**  
COULISSE HAUTE + COUVERTURE  
UPPER TRACK + COVER PROFILE  
GUIDA SUPERIORE + COPERTINA  
**\*5911/201 2 m**

Al	2 m	8-12 mm	€/u
----	-----	---------	-----

\*o



**PERFIL INFERIOR VIDRIO FIJO**  
PROFIL INFÉRIEUR VERRE FIXE  
BOTTOM PROFILE FIXED GLASS  
PROFLO INFERIORE VETRO FISSO  
con 5911  
**\*5912/101 1 m**

Al	1 m	8-12 mm	€/u
----	-----	---------	-----

\*o



**TAPA INFERIOR VIDRIO FIJO**  
COUVERTINE INFÉRIEUR VERRE FIXE  
BOTTOM COVER FIXED GLASS  
COPERTINA INFERIORE VETRO FISSO  
Se acopla a 5911  
**\*5913/101 1 m**

Al	1 m	8-12 mm	€/u
----	-----	---------	-----

\*o



**PINZA PORTAVIDRIO**  
PINCE POUR VERRE  
CLAMP FOR GLASS  
PINZA PER VETRO  
**\*5920/001**

Al Zn	100kg/2u.	€/u
8-12 mm		

\*o



**AMORTIGUADORES**  
AMORTISSEURS  
DUMPERS - SELFLOSING  
AMORTIZZATORE  
**\*5921/001**

Al plas	€/u
---------	-----

\*o



**STOP CARRIL SUPERIOR**  
STOP COULISSE HAUTE  
UPPER TRACK STOP  
STOP GUIDA SUPERIORE  
**\*5926/001 der.**  
**\*5927/001 izq.**

Al plas	€/u
---------	-----

\*o

\*o

se vende en kit



**MUELLE RELLAMADA PUERTA**  
AMORTISSEURS  
RECALLING  
MOLLA RICHIAMO PORTA  
**\*5922/001**

€/u
-----

\*o

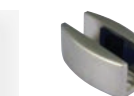

**GUÍA SUELO**  
GUIDAGE AU SOL  
FLOOR GUIDE  
GUIDA A PAVIMENTO  
**4352/028**

Al plas	€/u
---------	-----

o



**STOP SUELO**  
STOP AU SOL  
FLOOR STOP  
STOP A PAVIMENTO  
**\*5924/001**

Al plas	€/u
---------	-----

\*o



**REMATE FINAL CARRIL - GRIS**  
BOUCHON COULISSE - GRIS  
END-CAP TRACK - GRAY  
COPRITESTA TUBO - GRIGIO.  
**\*5925/009 kit der/izq**

Al	∞ 5910	€/u
----	--------	-----

\*o



**UÑERO DOBLE ADHESIVO**  
POIGNÉE DOUBLE ADHESIVE  
DOUBLE ADHESIVE PULL  
POMO DOPPIO ADHESIVO  
**4207/0..**  
**4207/0..**

∅ 60	€/u
------	-----

Al  
inox  
s.s.

o

o

o



**POMO**  
POIGNÉE  
KNOB  
POMO  
**4223/0..**

Al	100	€/u
----	-----	-----

8-10 mm
---------

o

o



## COTEK - SHANGHAI 60 KG

 PUERTAS CORREDERA CON AMORTIGUADOR - PORTES COULISSANTS AVEC AMORTISSEURS  
 SLIDING DOORS WITH DUMPERS - PORTE SCORREVOLI CON AMORTIZZATORI

### SHANGHAI

- peso max puerta: 60 kg
- vidrio puerta: 8-10 mm
- sin muesca en el vidrio

- poids limite pde: 60 kg/pde
- verre 8-10mm
- sans encoches
- weight max door: 60 kg/door
- glass 8-10mm
- without cutout
- peso max porta: 60 kg
- vetro 8-10mm
- senza tacca nel vetro

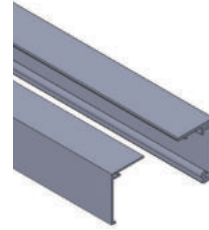

CARRIL + TAPA CARRIL  
 COULISSE HAUTE +  
 COUVERTURE COULISSE  
 UPPER TRACK +  
 COVER PROFIL  
 GUIDA SUPERIORE +  
 COPERTINA GUIDA  
**5130/201 2 m**  
**5130/301 3 m**



KIT PINZA PORTAVIDRIO CON  
 AMORTIGUADORES, GUIADOR  
 DE SUELO Y TAPAS FINALES  
 PINCE À VERRAVEC  
 AMORTISSEURS, GUIDE  
 CAPUCHONS DE SOL ET  
 D'EXTRÉMITÉ  
 GLASS CLAMP WITH  
 SHOCK ABSORBERS, GUIDE  
 FLOOR AND END CAPS  
 MORSETTO DI VETRO CON  
 AMMORTIZZATORI, GUIDA  
 TAPPI DI FONDO E DI FONDO  
**5133/001**



UÑERO DOBLE ADHESIVO  
 POIGNÉE DOUBLE ADHESIVE  
 DOUBLE ADHESIVE PULL  
 POMO DOPPIO ADHESIVO  
**4207/0..**  
**4207/0..**



GALGA MONTAJE UÑEROS  
 GABARIT DE MONTAGE  
 INSTALLATION TOOL  
 SAGOMA AIUTO MONTAGGIO  
**4209/000**



POMO  
 POIGNÉE  
 KNOB  
 POMO  
**4223/0..**

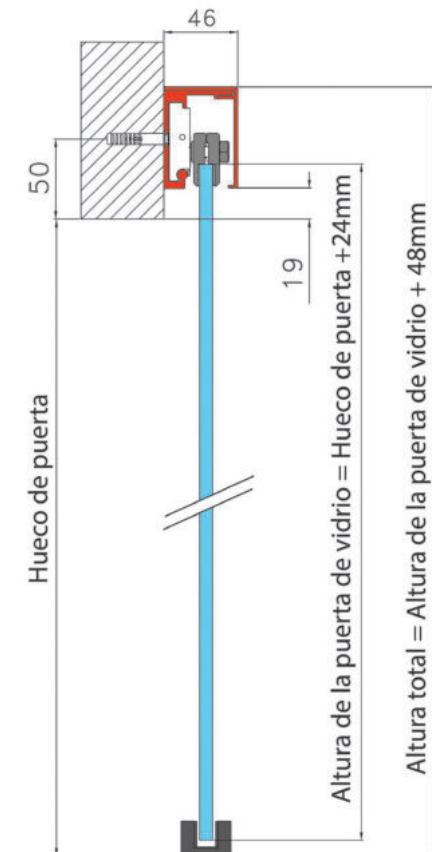

CP, BRILLO	PL, M	INOX BR	INOX SAT
CH, POJ	ALU, M	INOX POJ	INOX SAT
BR, CH	ALU, M	P.S.S.	S.S.S.
CP, LUC	ALL, NAT	INOX LUC	INOX SAT
32	01	22	28
Al	2 - 3m	43x61	€/u
	8 - 10 mm		
Al	60kg/2u.	282x33	€/u
	8 - 10 mm		
Al		Ø 60	€/u
Al inox s.s.			€/u
Al			€/u
Al	100		€/u
	8-10 mm		
			€/u
			€/u
			€/u
			€/u
			€/u

### MONTAJE A PARED

KIT DE PORTE COULISSANTE FIXÉE AU MUR  
 KIT SLIDING DOOR FIXED TO THE WALL  
 KIT PORTA SCORREVOLE FISSATA A PARETE

**5136/P21 2 m**  
**5136/P31 3 m**

CON AMORTIGUADOR  
 AVEC AMORTISSEURS,  
 WITH DUMPERS,  
 CON AMORTIZZATORI

5130/201-5130/301 1 u. carril + 1 u. tapa carril  
 5133/001 1 u. kit pinzas+buffer+  
 tapas finales+guiador suelo  
 4207/001 1 u. uñero



**COTEK - PLATEK 100 KG**

PUERTAS CORREDERA INOX - PORTES COULISSANTS INOX  
STAINLESS STEEL SLIDING DOORS - PORTE SCORREVOLI INOX

PLÁSTICO PLASTIQUE PLASTIC PLASTICA	INOX SAT INOX S.S.S. INOX SAT	SAT	ZINCADO PL. ZINK PL. ZINK PL. ZINCATO
09	28	34	

**PLATEK**

10-12 mm - max. 100kg

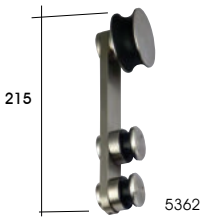

**COJINETE CHARLOT**  
ROLLER  
CUSCINETTO  
**5362/028 plano**

TALADRO NO AVELLANADO  
TROU NOT FRAISÉE  
DRILL NO COUNTERSINK  
FORO NON SVASATO

inox s.s.	10-12mm	50kg/u	€/u
	∅ 26 mm		



**TUBO-CARRIL**  
TUBE-COULISSE  
TUBE-TRACK  
TUBO-GUIDA  
**4350/328 3 m**  
**4350/228 2 m**

inox s.s.	L 2/3 m	∅25x2,5	€/u
-----------	---------	---------	-----



**REMATE FINAL CARRIL**  
BOUCHON COULISSE  
END-CAP TRACK  
COPRITESTA TUBO  
**236/0..**

∅ 25	€/u
------	-----



**GUÍA SUELO**  
GUIDAGE AU SOL  
FLOOR GUIDE  
GUIDA A PAVIMENTO  
**4352/028**

inox s.s.	10-12 mm	€/u
-----------	----------	-----



**STOP COJINETE**  
STOP CHARLOT  
STOP ROLLER  
STOP CUSCINETTO  
**5356/028 DERECHA**  
droite/right/destra  
**5357/028 IZQUIERDA**  
gauche/left/sinistra

inox s.s.	∅ 25	€/u
-----------	------	-----

5357

5356

**COTEK - PLATEK 100 KG**

PUERTAS CORREDERA INOX - PORTES COULISSANTS INOX  
STAINLESS STEEL SLIDING DOORS - PORTE SCORREVOLI INOX

PLÁSTICO PLASTIQUE PLASTIC PLASTICA	INOX SAT INOX S.S.S. INOX SAT	SAT	ZINCADO PL. ZINK PL. ZINK PL. ZINCATO
09	28	34	



**ANCLAJE CARRIL-PARED**  
FIXATION MUR-COULISSE  
CONNEXION WALL-TRACK  
CONNESSIONE PARETE-GUIDA  
**4355/028**

inox s.s.	∅ 25	€/u
-----------	------	-----



**CONEXIÓN TUBO-PARED**  
FIXATION TUBE-MUR  
CONNEXION TUBE-WALL  
CONNESSIONE TUBO-PARETE  
**4353/028**

inox s.s.	∅ 25	€/u
-----------	------	-----



TALADRO NO AVELLANADO  
TROU NOT FRAISÉE  
DRILL NO COUNTERSINK  
FORO NON SVASATO

**ANCLAJE VID.FIJO -CARRIL**  
FIXATION VERRE-COULISSE  
CONNEXION GLASS-TRACK  
CONNESSIONE VETRO-GUIDA  
**5354/028**

inox s.s.	10-12mm	∅ 25	€/u
	∅ 26 mm		



**UÑERO DOBLE ADHESIVO**  
POIGNÉE DOUBLE ADHESIVE  
DOUBLE ADHESIVE PULL  
POMO DOPPIO ADHESIVO  
**4207/0..**

inox s.s.	∅ 60	€/u
-----------	------	-----



**GALGA MONTAJE UÑEROS**  
GABARIT DE MONTAGE  
INSTALLATION TOOL  
SAGOMA AIUTO MONTAGGIO  
**4209/034**

Al	€/u
----	-----



**UÑERO POIGNÉE**  
KNOB  
POMO  
**4322/028**

inox s.s.	8-12 mm	€/u
	∅ 55 mm	



**UÑERO POIGNÉE**  
KNOB  
POMO  
**4337/028**

inox s.s.	8-12 mm	€/u
	∅ 46 mm	



**CONEXIÓN TUBO-TECHO**  
FIXATION TUBE-PLAFOND  
CONNEXION TUBE-CEILING  
CONNESSIONE TUBO-SOFFITTO  
**\*4363/028**

inox s.s.	∅ 25	€/u
-----------	------	-----



**HERRAJES PARA VIDRIOS FIJOS**  
SUPPORT MUR-VERRE  
BRACKET WALL-GLASS  
UNIONE PARTETE-VETRO  
**\*4370/028**

inox s.s.	10-12mm	€/u
	∅ 26 mm √ ∅ 32 mm	



**LLAVE REGULABLE x TORNILLO**  
OUTIL RÉGLABLE x VIS  
ADJUSTABLE TOOL x SCREWS  
UTENSILE REGOLABILE x VITI  
**4398/034**

inox s.s.	10-12mm	€/u
-----------	---------	-----



**CONEXIÓN 90° CARRIL**  
FIXATION COULISSE 90°  
TRACKS CONNEXION 90°  
CONNESSIONE GUIDE 90°  
**\*4365/028**

inox s.s.	∅ 25	∞ 4350	€/u
-----------	------	--------	-----

**STOP COJINETE**  
STOP CHARLOT  
STOP ROLLER  
STOP CUSCINETTO  
**\*4366/028**

inox s.s.	∅ 25	∞ 4365	€/u
-----------	------	--------	-----

# COTEK - PLATEK 100 KG

PUERTAS CORREDERA INOX - PORTES COULISSANTS INOX  
STAINLESS STEEL SLIDING DOORS - PORTE SCORREVOLI INOX

## PLATEK - KIT PUERTA CORREDERA VIDRIO

### PUERTA CORREDERA VIDRIO A PARED

*KIT DE PORTE COULISSANTE FIXÉE AU MUR*  
*KIT SLIDING DOOR FIXED TO THE WALL*  
*KIT PORTA SCORREVOLE FISSATA A PARETE*

#### 5379/P28 con tubo 2 m

- 4350/228 1 u. tubo 2 m
- 4352/028 1 u. guía inf. "u"
- 236/0028 2 u. tapón final
- 5356/028 1 u. tope cojinete
- 5357/028 1 u. tope cojinete
- 5362/028 2 u. cojinete
- 4337/028 1 u. uñero
- 4353/028 4 u. fijación tubo-pared

○ €/u

#### 5380/P28 con tubo 3 m

- 4350/328 1 u. tubo 3 m
- 4352/028 1 u. guía inf. "u"
- 236/028 2 u. tapón final
- 5356/028 1 u. tope cojinete
- 5357/028 1 u. tope cojinete
- 5362/028 2 u. cojinete
- 4337/028 1 u. uñero
- 4353/028 6 u. fijación tubo-pared

○ €/u

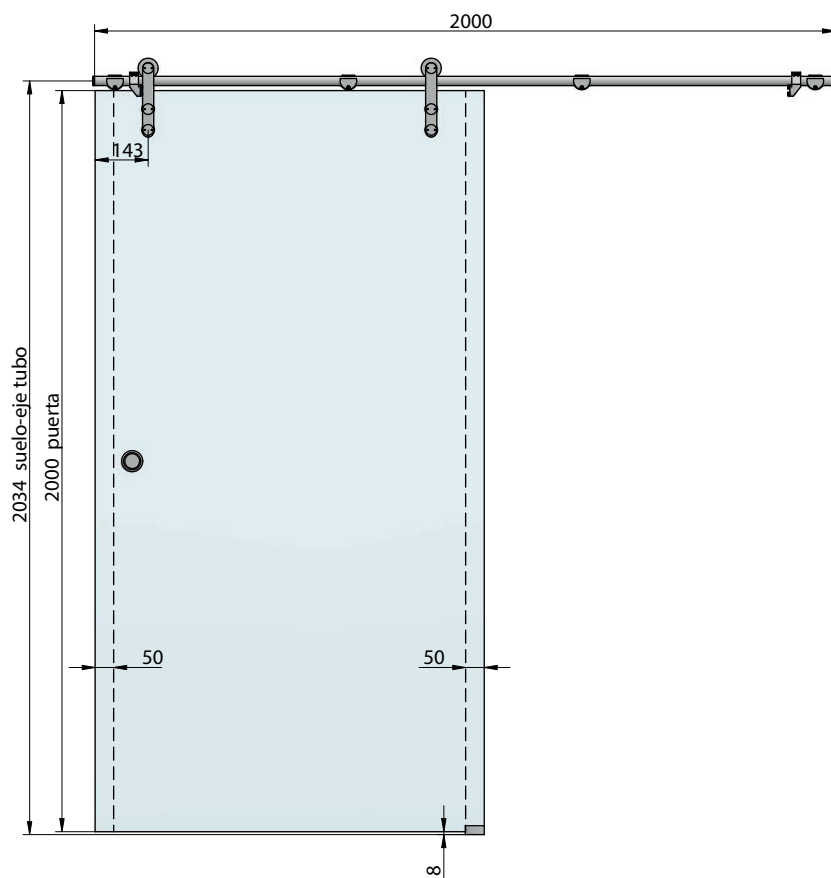

### PUERTA CORREDERA VIDRIO + VIDRIO FIJO

*KIT DE PORTE COULISSANTE FIXÉE AU MUR DE VERRE*  
*KIT SLIDING DOOR FIXED TO THE GLASS-WALL*  
*KIT PORTA SCORREVOLE FISSATA A PARETE DI VETRO*

#### 5369/P28 con tubo 2 m

- 4350/228 1 u. tubo 2 m
- 4352/028 1 u. guía inf. "u"
- 236/028 2 u. tapón final
- 5356/028 1 u. tope cojinete
- 5357/028 1 u. tope cojinete
- 5362/028 2 u. cojinete
- 4337/028 1 u. uñero
- 5354/028 4 u. fijación tubo-vidrio

○ €/u

#### 5381/P28 con tubo 3 m

- 4350/328 1 u. tubo 3 m
- 4352/028 1 u. guía inf. "u"
- 236/028 2 u. tapón final
- 5356/028 1 u. tope cojinete
- 5357/028 1 u. tope cojinete
- 5362/028 2 u. cojinete
- 4337/028 1 u. uñero
- 5354/028 6 u. fijación tubo-vidrio

○ €/u

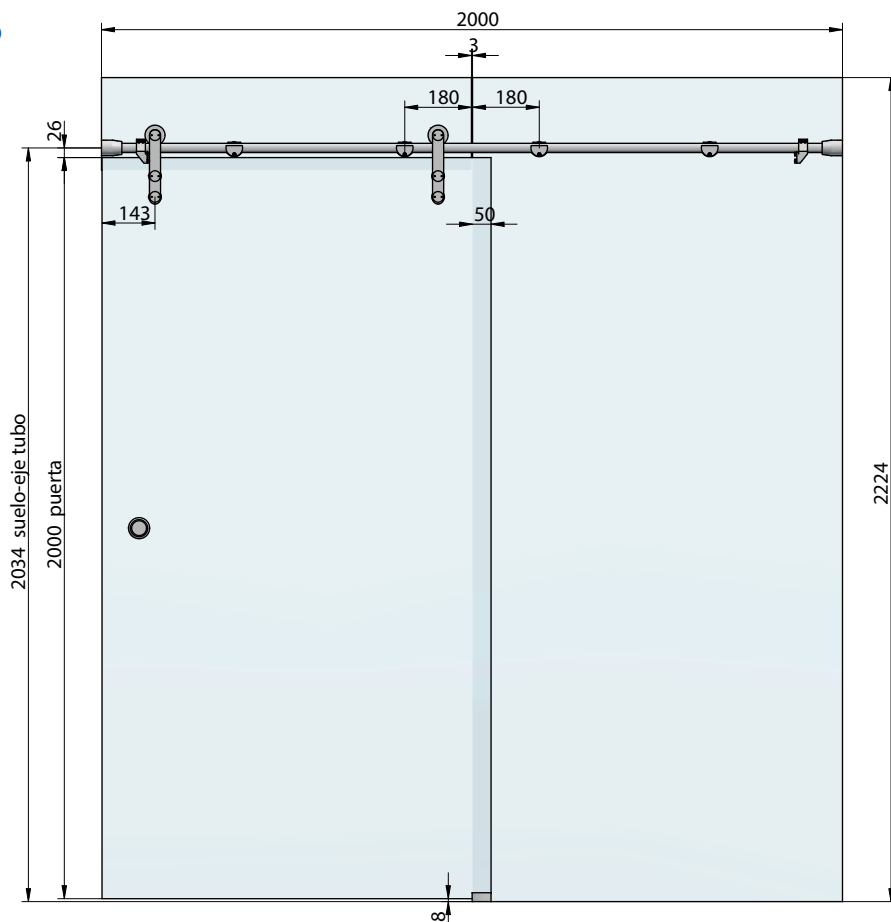

**COTEK - PISA 100 KG**PUERTAS CORREDERAS CON AMORTIGUADOR - PORTES COULISSANTS AVEC AMORTISSEURS  
SLIDING DOORS WITH DUMPERS - PORTE SCORREVOLI CON AMORTIZZATORI**PISA**

- peso max. puerta: 100 kg/puerta
- vidrio 8-10 mm
- con o sin muesca en el vidrio

- pods-limite porte: 100 kg/porte
- verre 8-10 mm
- encoches - sans encoches

- weight max. door: 100 kg/door
- glass 8-10 mm
- cut-out - without cut-out

- peso max. porta: 100 kg/porta
- vetro 8-10 mm
- tacca - senza tacca nel vetro

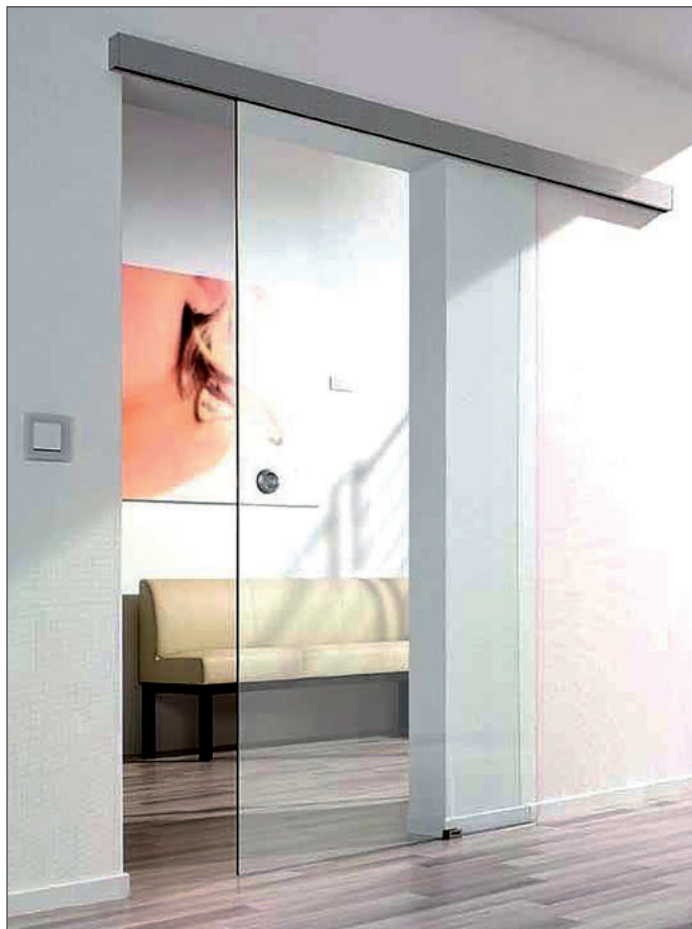
**PINZAS OCULTAS**

- Modelo PISA con tapa frontal ref. 3471/101, tapas laterales ref. 3474/001 y kit pinzas 3478/001. Peso máximo de 100 kg/puerta. Para vidrio laminado o templado de 8-10 mm.
- Modèle PISA avec couvercle avant réf. 3471/101, couvercles latéraux réf. 3474/001 et kit d'étrier 3478/001. Poids maximum de 100 kg / porte. Pour le verre feuilleté ou trempé de 8-10 mm.
- PISA model with front cover ref. 3471/101, side covers ref. 3474/001 and caliper kit 3478/001. Maximum weight of 100 kg / door. For laminated or tempered glass of 8-10 mm.
- Modello PISA con coperchio anteriore rif. 3471/101, coperture laterali rif. 3474/001 e kit pinza 3478/001. Peso massimo di 100 kg / porta. Per vetro stratificato o temperato di 8-10 mm.

**PISA**

- peso max. puerta: 100 kg/puerta
- vidrio 8-10 mm
- con muesca en el vidrio

- pods-limite porte: 100 kg/porte
- verre 8-10 mm
- encoches

- weight max. door: 100 kg/door
- glass 8-10 mm
- cut-out

- peso max. porta: 100 kg/porta
- vetro 8-10 mm
- tacca nel vetro

**PINZAS A LA VISTA CON TAPAS EMBELLECEDORAS**

- Modelo PISA con tapa frontal ref. 3472/101, tapas laterales ref. 3473/001 y kit pinzas 3476/001. Peso máximo de 100 kg/puerta. Para vidrio templado de 8-10 mm.
- Modèle PISA avec couvercle avant réf. 3472/101, couvercles latéraux réf. 3473/001 et kit d'étrier 3476/001. Poids maximum de 100 kg / porte. Pour verre trempé de 8-10 mm.
- PISA model with front cover ref. 3472/101, side covers ref. 3473/001 and caliper kit 3476/001. Maximum weight of 100 kg / door. For tempered glass of 8-10 mm.
- Modello PISA con coperchio anteriore rif. 3472/101, coperture laterali rif. 3473/001 e kit pinza 3476/001. Peso massimo di 100 kg / porta. Per vetri temperati di 8-10 mm.



## COTEK - PISA 100KG

PUERTAS CORREDERAS CON AMORTIGUADOR - PORTES COULISSANTS AVEC AMORTISSEURS  
SLIDING DOORS WITH DUMPERS - PORTE SCORREVOLI CON AMORTIZZATORI

KIT PINZAS DE 100KG CON BUFFER Y 2 PINZAS  
3478/001

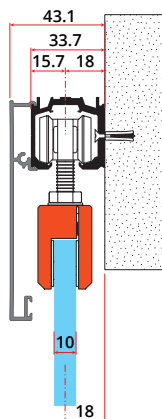
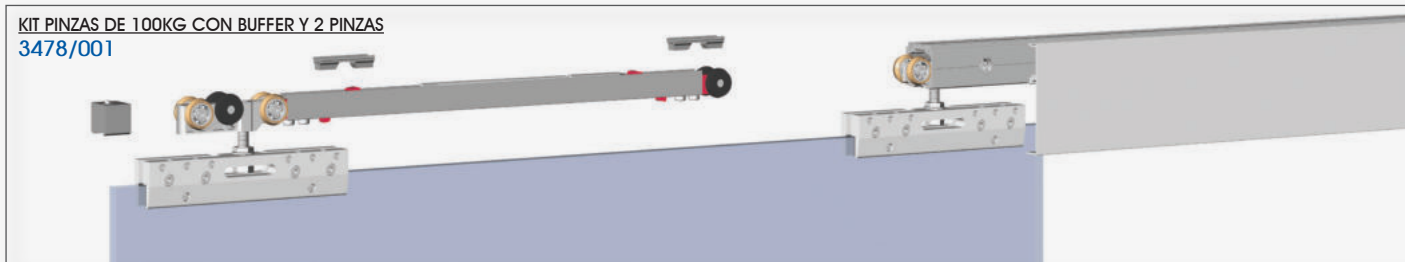

- Fijación a pared con tapa lateral.
- Fixation au mur avec couverture latéral.
- Fixing to the wall with side cover.
- Fissaggio al muro con copertura laterale.

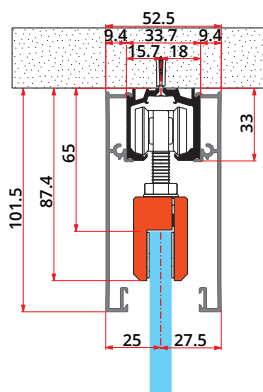

- Fijación a techo con tapas laterales.
- Fixation au plafond avec des couvertures latéraux.
- Fixation to ceiling with side covers.
- Fissaggio a soffitto con copertura laterali.

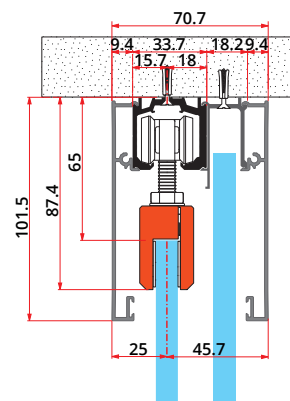

- Fijación a techo con tapas laterales y cristal fijo.
- Fixation au plafond avec des couvertures latéraux et verre fixe.
- Fixing to the ceiling with side covers and fixed glass.
- Fissaggio al soffitto con copertura laterali e vetro fisso.

KIT PINZAS DE 100KG CON BUFFER Y 2 PINZAS  
3476/028

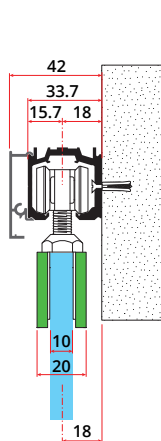
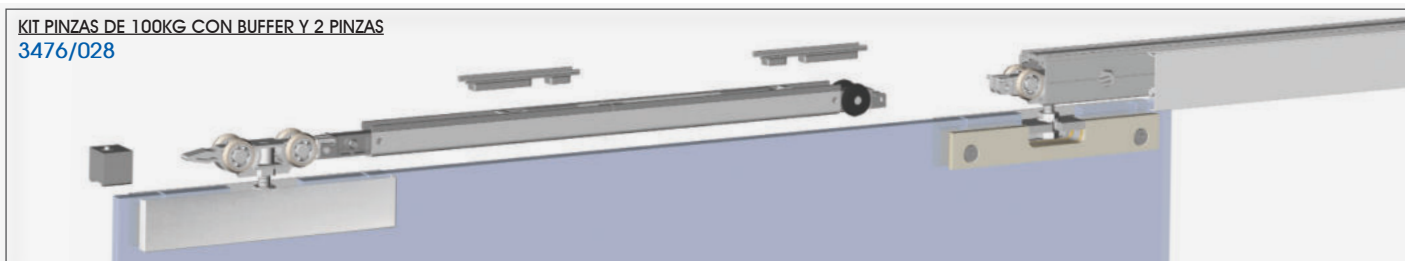

- Fijación a pared con tapa lateral.
- Fixation au mur avec couvercle latéral.
- Fixing to the wall with side cover.
- Fissaggio al muro con copertura laterale.

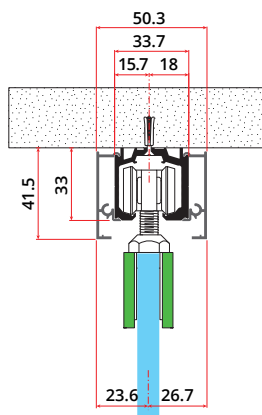

- Fijación a techo con tapas laterales.
- Fixation au plafond avec des couvertures latéraux.
- Fixation to ceiling with side covers.
- Fissaggio a soffitto con copertura laterali.

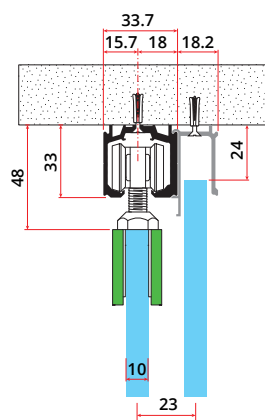

- Fijación a techo con cristal fijo.
- Fixation au plafond avec verre fixe.
- Fixing to the ceiling with fixed glass.
- Fissaggio al soffitto con vetro fisso.

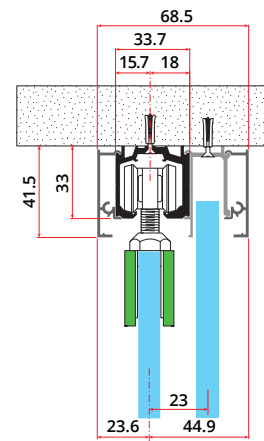

- Fijación a techo con tapas laterales y cristal fijo.
- Fixation au plafond avec des couvertures latéraux du verre fixe.
- Fixing to the ceiling with side covers and fixed glass.
- Fissaggio al soffitto con copertura laterali e vetro fisso.

# COTEK - \*PISA

CORREDERA - COULISSANTS  
SLIDING DOOR - SCORREVOLI

ALU. M  
ALU. M  
ALU. M  
ALL. NAT  
**01**

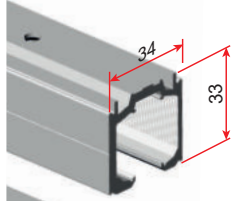

**CARRIL SUPERIOR**  
RAIL EN ALUMINIUM  
ALUMINIUM RAIL  
BINARIO IN ALLUMINIO  
**\*3470/101**  
FACTURACIÓN EN 2M., 3M Y 4M.

Al	6 m	€/m
----	-----	-----

\*o

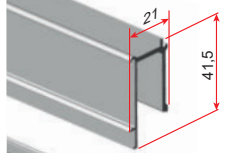

**PERFIL PARA VIDRIO FIJO**  
PROFIL POUR VERRE FIXE  
PROFILE FOR FIXED GLASS  
PROFLO PER VETRO FISSO  
**\*3475/101**  
FACTURACIÓN EN 2M., 3M Y 4M.

Al	∅3470	6 m	€/m
----	-------	-----	-----

\*o

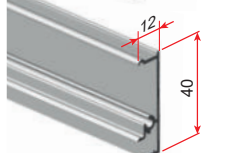

**TAPA DE CARRIL SUPERIOR**  
COUVERTURE DE RAIL SUPÉRIEURE  
TOP RAIL COVER  
COPERTURA SUPERIORE DEL BINARIO  
**\*3472/101**  
FACTURACIÓN EN 2M., 3M Y 4M.

Al	∅3476	6 m	€/m
----	-------	-----	-----

\*o

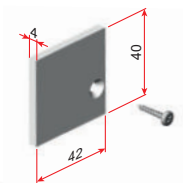

**TAPA LATERAL DE CARRIL SUPERIOR**  
COUVERTURE LATÉRALE DU RAIL SUPÉRIEUR  
TOP RAIL SIDE COVER  
COPERTURA LATERALE SUPERIORE  
**\*3473/001** Set dcha. izda.

Al	∅ 3472	€/u
----	--------	-----

\*o

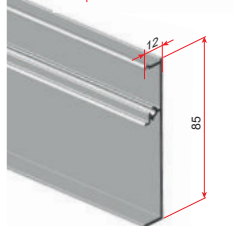

**TAPA DE CARRIL SUPERIOR**  
COUVERTURE DE RAIL SUPÉRIEURE  
TOP RAIL COVER  
COPERTURA SUPERIORE DEL BINARIO  
**\*3471/101**  
FACTURACIÓN EN 2M., 3M Y 4M.

Al	∅3478	6 m	€/m
----	-------	-----	-----

\*o

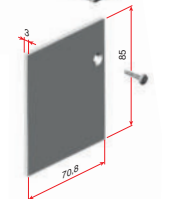

**TAPA LATERAL DE CARRIL SUPERIOR**  
COUVERTURE LATÉRALE DU RAIL SUPÉRIEUR  
TOP RAIL SIDE COVER  
COPERTURA LATERALE SUPERIORE  
**\*3474/001** Set dcha. izda.

Al	∅3471	€/u
----	-------	-----

\*o



Al	∅3474 ∅3471	100kg/u	€/u
----	----------------	---------	-----

**KIT COJINETES Y 2 PINZAS PARA CRISTAL.**  
KIT CHARIOT ET 2 PINCE POUR VERRE.  
KIT TOP ROLLERS AND 2 CLAMPS FOR GLASS.  
KIT SCORREVOLI E 2 PINZE PER VETRO  
**3478/001**

o



inox s.s.	∅3472 ∅3473 ∅3477	100kg/u	€/u
-----------	-------------------------	---------	-----

**KIT COJINETES Y 2 PINZAS PARA CRISTAL.**  
KIT CHARIOT ET 2 PINCE POUR VERRE.  
KIT TOP ROLLERS AND 2 CLAMPS FOR GLASS.  
KIT SCORREVOLI E 2 PINZE PER VETRO  
**3476/028**

o

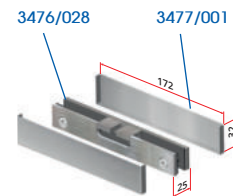

**KIT DE 2 TAPAS PARA PINZAS.**  
LOT DE 2 COUVERCLES POUR PINCES.  
SET OF 2 CAPS FOR CLAMP  
KIT 2 VELLETTA PINZA.  
**3477/001**

Solo para KIT 3476

ALU. M  
ALU. M  
ALU. M  
ALL. NAT  
**01**  
inox s.s. €/u  
∅3476

o

# COTEK - \*PISA

CORREDERA - COULISSANTS  
SLIDING DOOR - SCORREVOLI

ALU. M  
ALU. M  
ALU. M  
ALL. NAT  
**01**

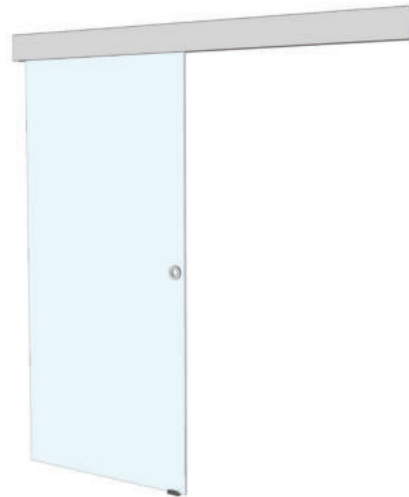

## MONTAJE A PARED

**3490/P21** 2 m  
**3490/P31** 3 m

**KIT PUERTA CORREDERA A PARED.**  
KIT DE PORTE COULISSANTE FIXÉE AU MUR  
KIT SLIDINGDOOR FIXED TO THE WALL  
KIT PORTA SCORREVOLE FISSATA APARETE  
3470/101 2/3 m. Carril  
3471/101 2/3 m. Tapa carril grande  
3474/001 1 u. Set de tapas laterales  
4207/001 1 u. Uñero adhesivo  
3478/001 1 u. Kit pinzas para cristal LAMINADO/TEMLADO  
Incluye guizador para el suelo.

o  
o  
€/u

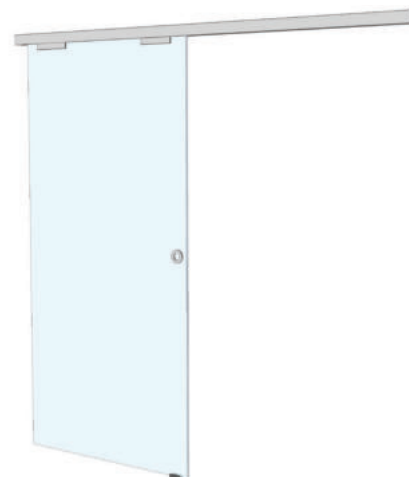
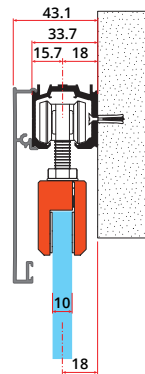

## MONTAJE A PARED

**3491/P21** 2 m  
**3491/P31** 3 m

**KIT PUERTA CORREDERA A PARED.**  
KIT DE PORTE COULISSANTE FIXÉE AU MUR  
KIT SLIDINGDOOR FIXED TO THE WALL  
KIT PORTA SCORREVOLE FISSATA APARETE  
3470/101 2/3 m. Carril.  
3472/101 2/3 m. Tapa carril pequeña.  
3473/001 1 u. Set de tapas laterales.  
4207/001 1 u. Uñero adhesivo.  
3476/028 1 u. Kit pinzas INOX para cristal TEMPLADO.  
Incluye guizador para el suelo.

o

o

€/u

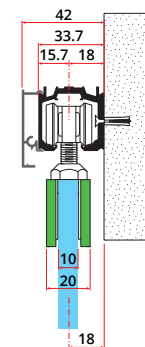

NO Incluye:  
3477/001

## COTEK - PISA

CORREDERA - COULISSANTS  
SLIDING DOOR - SCORREVOLI

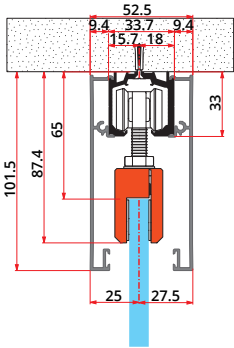
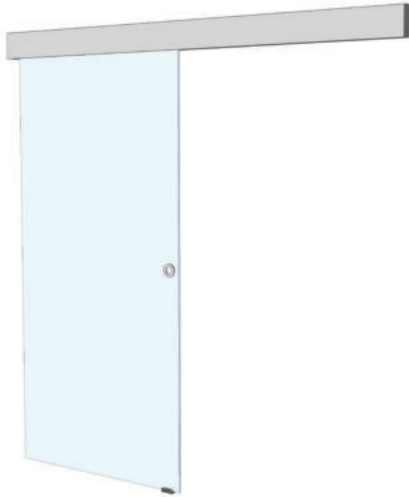

### MONTAJE A TECHO

3492/T21 2 m

3492/T31 3 m

KIT PUERTA CORREDERA A TECHO

KIT DE PORTE COULISSANTE FIXÉE AU TOIT

KIT SLIDING DOOR FIXED TO THE CEILING

KIT PORTA SCORREVOLE FISSATA A TETTO

3470/101 2/3 m. Carril.

3471/101 4/6 m. Tapa carril grande.

3474/001 1 u. Set tapas laterales.

4207/001 1 u. Uñero adhesivo.

3478/001 1 u. Kit pinzas para cristal LAMINADO / TEMPLADO.

Incluye guizador para el suelo.

ALU. M  
ALU. M  
ALU. M  
ALL. NAT  
01

○  
○  
€/u

## COTEK - PISA

CORREDERA - COULISSANTS  
SLIDING DOOR - SCORREVOLI

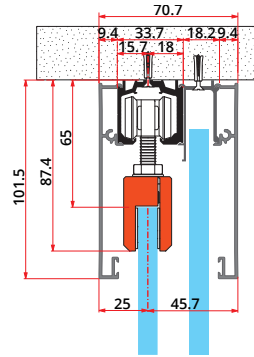
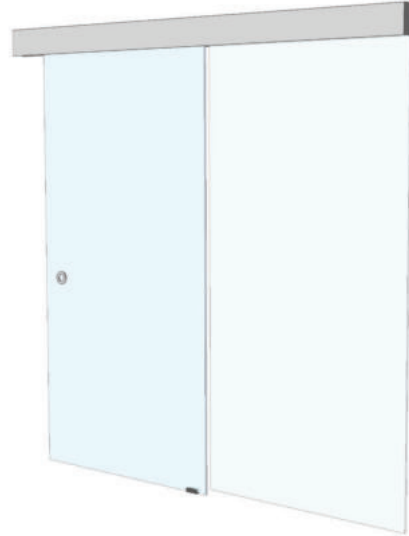

### MONTAJE A TECHO + VIDRIO FIJO

3494/T21 2 m

3494/T31 3 m

KIT PUERTA CORREDERA A TECHO CON VIDRIO FIJO

KIT PORTE COULISSANTE AVEC VITRE FIXE

ROOF SLIDING DOOR KIT WITH FIXED GLASS

KIT PORTA SCORREVOLE SUL TETTO CON VETRO FISSO

3470/101 2/3 m. Carril.

3471/101 4/6 m. Tapa carril grande.

3474/001 1 u. Set de tapas laterales

3475/101 2/3 m. Carril para vidrio fijo.

4207/001 1 u. Uñero adhesivo.

3478/001 1 u. Kit pinzas para cristal LAMINADO / TEMPLADO.

Incluye guizador para el suelo.

ALU. M  
ALU. M  
ALU. M  
ALL. NAT  
01

○  
○  
€/u

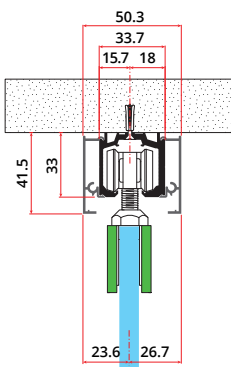
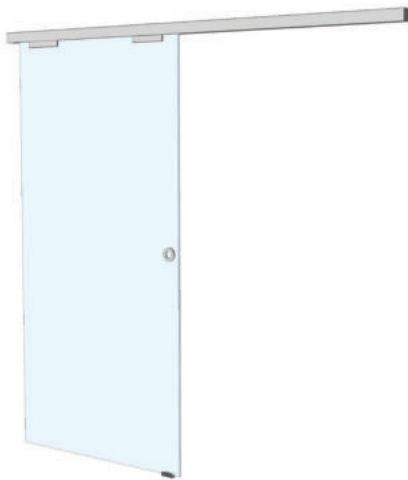

### MONTAJE A TECHO

3493/T21 2 m

3493/T31 3 m

KIT PUERTA CORREDERA A TECHO

KIT DE PORTE COULISSANTE FIXÉE AU TOIT

KIT SLIDING DOOR FIXED TO THE CEILING

KIT PORTA SCORREVOLE FISSATA A TETTO

3470/101 2/3 m. Carril.

3472/101 4/6 m. Tapa carril pequeña.

3473/001 1 u. Set tapas laterales.

4207/001 1 u. Uñero adhesivo.

3476/028 1 u. Kit pinzas INOX para cristal TEMPLADO.

Incluye guizador para el suelo.

NO Incluye:

3477/001

○  
○  
€/u

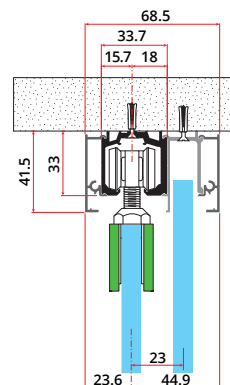
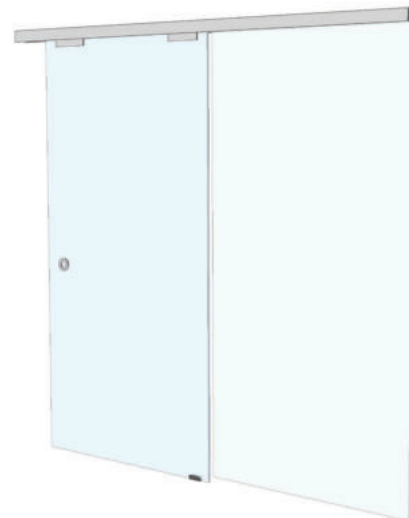

### MONTAJE A TECHO + VIDRIO FIJO

3495/T21 2 m

3495/T31 3 m

KIT PUERTA CORREDERA A TECHO CON VIDRIO FIJO

KIT PORTE COULISSANTE AVEC VITRE FIXE

ROOF SLIDING DOOR KIT WITH FIXED GLASS

KIT PORTA SCORREVOLE SUL TETTO CON VETRO FISSO

3470/101 2/3 m. Carril.

3472/101 4/6 m. Tapa carril pequeña.

3473/001 1 u. Set de tapas laterales.

3475/101 2/3 m. Carril para vidrio fijo.

4207/001 1 u. Uñero adhesivo.

3476/028 1 u. Kit pinzas INOX para cristal TEMPLADO.

Incluye guizador para el suelo.

NO Incluye:

3477/001

○  
○  
€/u

**COTEK - MONZA 100 KG**PUERTAS CORREDERAS CON AMORTIGUADOR - PORTES COULISSANTS AVEC AMORTISSEURS  
SLIDING DOORS WITH DUMPERS - PORTE SCORREVOLI CON AMORTIZZATORI**MONZA**

- peso max. puerta: 100 kg/puerta
- vidrio 8-10 mm
- con o sin muesca en el vidrio

- pods-limite porte: 100 kg/porte
- verre 8-10 mm
- encoches - sans encoches

- weight max. door: 100 kg/door
- glass 8-10 mm
- cut-out - without cut-out

- peso max. porta: 100 kg/porta
- vetro 8-10 mm
- tacca - senza tacca nel vetro

**PINZAS OCULTAS**

- Modelo MONZA con tapa frontal ref. 3481/101 y kit pinzas 3478/001. Peso máximo de 100 kg/puerta. Para vidrio laminado o templado de 8-10 mm.
- Modèle MONZA avec couvercle avant réf. 3481/101 et kit d'étrier 3478/001. Poids maximum de 100 kg / porte. Pour le verre feuilleté ou trempé de 8-10 mm.
- MONZA model with front cover ref. 3481/101 and caliper kit 3478/001. Maximum weight of 100 kg / door. For laminated or tempered glass of 8-10 mm.
- Modello MONZA con coperchio anteriore rif. 3481/101 e kit pinza 3478/001. Peso massimo di 100 kg / porta. Per vetro stratificato o temperato di 8-10 mm.

**MONZA**

- peso max. puerta: 100 kg/puerta
- vidrio 8-10 mm
- con muesca en el vidrio

- pods-limite porte: 100 kg/porte
- verre 8-10 mm
- encoches

- weight max. door: 100 kg/door
- glass 8-10 mm
- cut-out

- peso max. porta: 100 kg/porta
- vetro 8-10 mm
- tacca nel vetro

**PINZAS A LA VISTA CON TAPAS EMBELLECEDORAS**

- Modelo MONZA con carril empotrado y kit pinzas 3476/001. Peso máximo de 100 kg/puerta. Para vidrio templado de 8-10 mm.
- Modèle MONZA avec rail encastré et kit de clips 3476/001. Poids maximum de 100 kg / porte. Pour verre trempé de 8-10 mm.
- MONZA model with recessed rail and clip kit 3476/001. Maximum weight of 100 kg / door. For tempered glass of 8-10 mm.
- Modello MONZA con binario incassato e kit clip 3476/001. Peso massimo di 100 kg / porta. Per vetri temperati di 8-10 mm.





## COTEK - MONZA 100KG

PUERTAS CORREDERAS CON AMORTIGUADOR - PORTES COULISSANTS AVEC AMORTISSEURS  
SLIDING DOORS WITH DUMPERS- PORTE SCORREVOLI CON AMORTIZZATORI

KIT PINZAS DE 100KG CON BUFFER Y 2 PINZAS  
3478/001

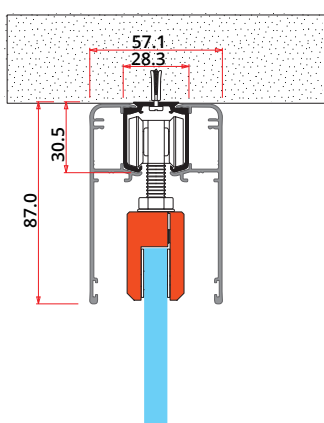

- Fijación a techo con tapas laterales.
- Fixation au plafond avec des couvertures latérales.
- Fixation to ceiling with side covers.
- Fissaggio a soffitto con coperture laterali

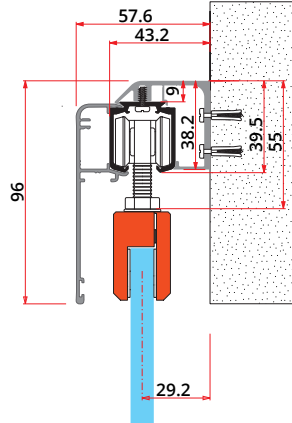

- Fijación a pared con tapa lateral.
- Fixation au mur avec couvertures latéral.
- Fixing to the wall with side cover.
- Fissaggio al muro con coperchio laterale.

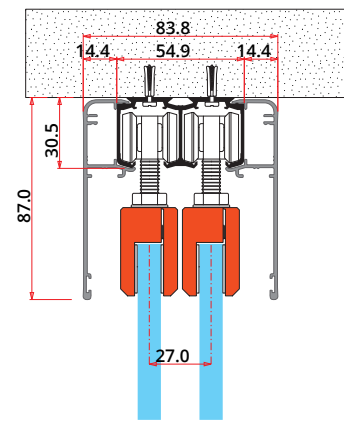

- CONSULTAR PRECIO Y PLAZO DE ENTREGA. Fijación a techo con tapas laterales.
- VÉRIFIEZ LE PRIX ET LE DÉLAI DE LIVRAISON. Fixation au plafond avec des couvertures latérales.
- CHECK PRICE and DELIVERY PERIOD. Fixation to ceiling with side covers.
- CONSULTARE PREZZO e TEMPI DI CONSEGNA. Fissaggio a soffitto con coperture laterali

KIT PINZAS DE 100KG CON BUFFER Y 2 PINZAS  
3476/028

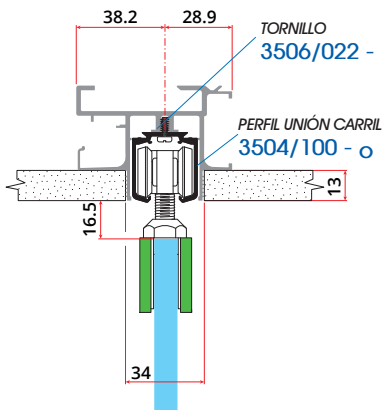

- Carril empotrado para falso techo.
- Rail encastré pour faux plafond.
- Recessed rail for false ceiling.
- Binario ad incasso per controsoffitto.

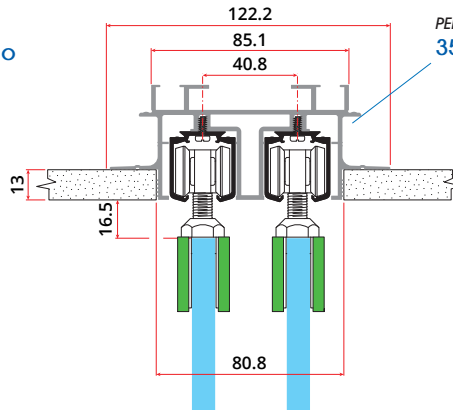

- Carril doble empotrado para falso techo.
- Double rail en retrait pour faux plafond.
- Double rail recessed for false ceiling.
- Doppia pista da incasso per controsoffitto

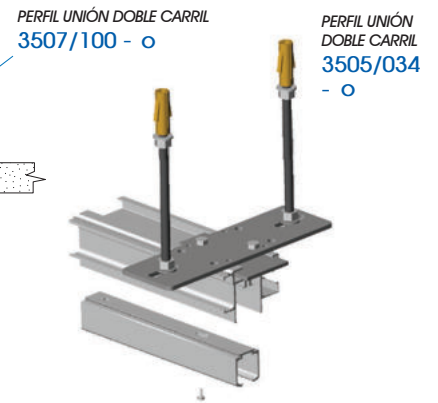

- Anclaje al techo.
- Ancre de toit.
- Roof anchor.
- Fissaggio a tetto.

# COTEK - MONZA

CORREDERA - COULISSANTS  
SLIDING DOOR - SCORREVOLI

ALU. M  
ALU. M  
ALU. M  
ALL. NAT  
**01**

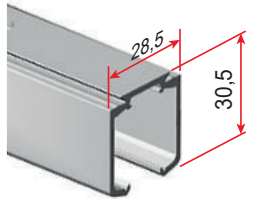

**CARRIL SUPERIOR**  
RAIL EN ALUMINIUM  
ALUMINIUM RAIL  
BINARIO IN ALLUMINIO  
**3480/101**  
FACTURACIÓN EN 2M, 3M Y 4M.

Al 6 m €/m

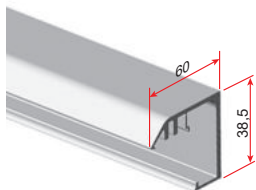

**PERFIL DE ANCLAJE A PARED**  
PROFIL D'ANCRAGE MURAL  
WALL ANCHOR PROFILE  
PROFILE PER FISSAGGIO A PARETE  
**3482/101**  
FACTURACIÓN EN 2M, 3M Y 4M.

Al 3480 6 m €/m

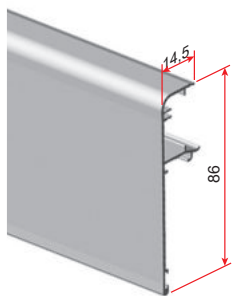

**TAPA DE CARRIL SUPERIOR**  
COUVERTURE DE RAIL SUPERIEURE  
TOP RAIL COVER  
COPERTURA SUPERIORE DEL BINARIO  
**3481/101**  
FACTURACIÓN EN 2M, 3M Y 4M.

Al 3478 6 m €/m



**TORNILLOS ESPECIALES AUTOROSCANTES**  
VIS DE FIXATION  
FIXING SCREW  
VITE DI FISSAGGIO  
**3483/001**

inox s.s. 3482 €/u



**KIT COJINETES Y 2 PINZAS PARA CRISTAL.**  
KIT CHARIOT ET 2 PINCE POUR VERRE.  
KIT TOP ROLLERS AND 2 CLAMPS FOR GLASS.  
KIT SCORREVOLI E 2 PINZE PER VETRO  
**3478/001**

Al 8-10mm 100kg/u €/u



**KIT COJINETES Y 2 PINZAS PARA CRISTAL.**  
KIT CHARIOT ET 2 PINCE POUR VERRE.  
KIT TOP ROLLERS AND 2 CLAMPS FOR GLASS.  
KIT SCORREVOLI E 2 PINZE PER VETRO  
**3476/028**

inox s.s. 8-10mm 100kg/u €/u

INOX SAT  
INOX SAT  
S.S.S.  
INOX SAT  
**28**

3477

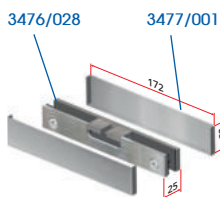

**KIT DE 2 TAPAS PARA PINZAS.**  
LOT DE 2 COUVERCLES POUR PINCES.  
SET OF 2 CAPS FOR CLAMP  
KIT 2 VELLETTA PINZA.  
**3477/001**

Solo para KIT 3476

ALU. M  
ALU. M  
ALU. M  
ALL. NAT  
**01**

inox s.s. €/u

3476

# COTEK - MONZA

CORREDERA - COULISSANTS  
SLIDING DOOR - SCORREVOLI

ALU. M  
ALU. M  
ALU. M  
ALL. NAT  
**01**

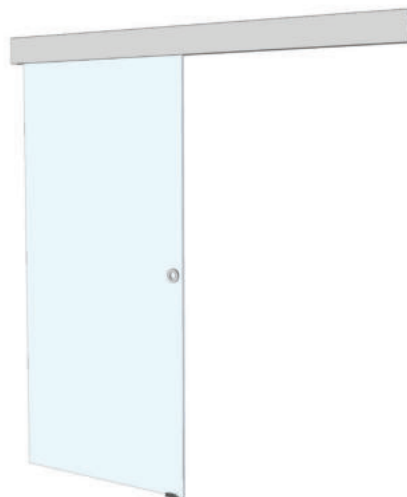

## MONTAJE A PARED

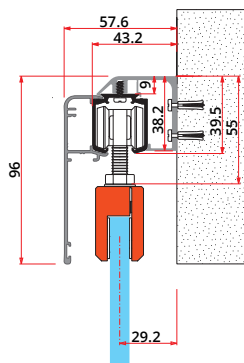

**3500/P21** 2 m  
**3500/P31** 3 m

**KIT PUERTA CORREDERA A PARED**

**KIT DE PORTE COULISSANTE FIXEE AU MUR**

**KIT SLIDING DOOR FIXED TO THE WALL**

**KIT PORTA SCORREVOLE FISSATA A PARETE**

3480/101 2/3 m. Carril.

3481/101 2/3 m. Tapa carril grande.

3482/101 2/3 m. Perfil para pared.

3483/001 6/8 u. Tornillo especial para fijación.

4207/001 1 u. Uñero adhesivo.

3478/001 1 u. Kit pinzas para cristal LAMINADO y TEMPLADO.

Incluye guizador para el suelo.

0

0

€/u

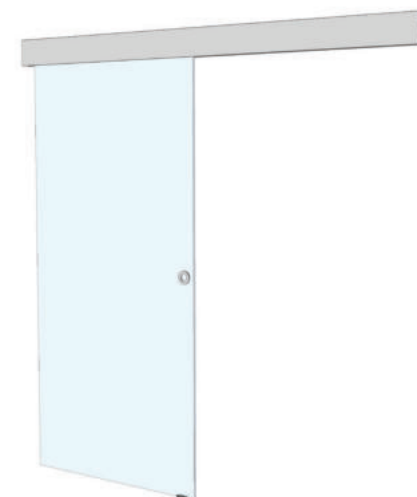

## MONTAJE A TECHO

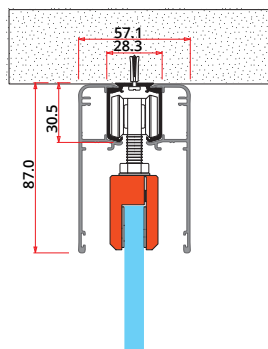

**3501/T21** 2 m  
**3501/T31** 3 m

**KIT PUERTA CORREDERA A TECHO**

**KIT DE PORTE COULISSANTE FIXEE AU TOIT**

**KIT SLIDING DOOR FIXED TO THE CEILING**

**KIT PORTA SCORREVOLE FISSATA A TETTO**

3480/101 2/3 m. Carril.

3481/101 4/6 m. Tapa carril grande.

4207/001 1 u. Uñero adhesivo.

3478/001 1 u. Kit pinzas para cristal LAMINADO y TEMPLADO.

Incluye guizador para el suelo.

0

0

€/u

## COTEK - MONZA

CORREDERA - COULISSANTS  
SLIDING DOOR - SCORREVOLI

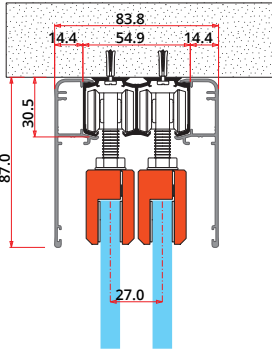

### MONTAJE TIPO FRENTE DE ARMARIO

3502/T21 2 m  
3502/T31 3 m

KIT PUERTA CORREDERA A TECHO  
KIT DE PORTE COULISSANTE FIXÉE AU TOIT  
KIT SLIDING DOOR FIXED TO THE CEILING  
KIT PORTA SCORREVOLE FISSATA A TETTO

3480/101 4/6 m. Carril.  
3481/101 4/6 m. Tapa carril grande.  
4207/001 2 u. Uñero adhesivo.  
3478/001 2 u. Kit pinzas para cristal LAMINADO y TEMPLADO.

Incluye guiador para el suelo.

ALU. M  
ALU. M  
ALU. M  
ALL. NAT  
01

○  
○  
€/u

## COTEK - UÑEROS



UÑERO DOBLE ADHESIVO  
POIGNÉE DOUBLE ADHESIVE  
DOUBLE ADHESIVE PULL  
POMO DOPPIO ADHESIVO  
4207/0..



GALGA MONTAJE UÑEROS  
GABARIT DE MONTAGE  
INSTALLATION TOOL  
SAGOMA AUTOMONTAGGIO  
4209/000



UÑERO  
POIGNÉE  
KNOB  
POMO  
4337/028



POMO  
POIGNÉE  
KNOB  
POMO  
4223/0..



UÑERO  
POIGNÉE  
KNOB  
POMO  
4322/028

PL. M ALU. M ALU. M ALL. NAT	INOX NOX P.S.S. NOX IWC	BR POJ NOX IWC	INOX SAT INOX SAT S.S.S. INOX SAT	CP. BRILLO CR. POLI BR. CR CR. IWC	01	22	28	32
					Al	Ø6 m	€/u	
				NEGRO NOR BLACK NERO ON				
					Al		€/u	
				NEGRO NOR BLACK NERO ON				
inox s.s.	8-12 mm	Ø 46 mm	€/u					
Al	100	8-10 mm	€/u					
inox s.s.	Ø 50 mm	8-12 mm	€/u					

# COTEK - PISA / MONZA

PUERTAS CORREDERA - PORTES COULISSANTES  
SLIDING DOORS - PORTE SCORREVOLI

## KIT 3478/001 PARA PUERTA CON BUFFER - 100 Kg

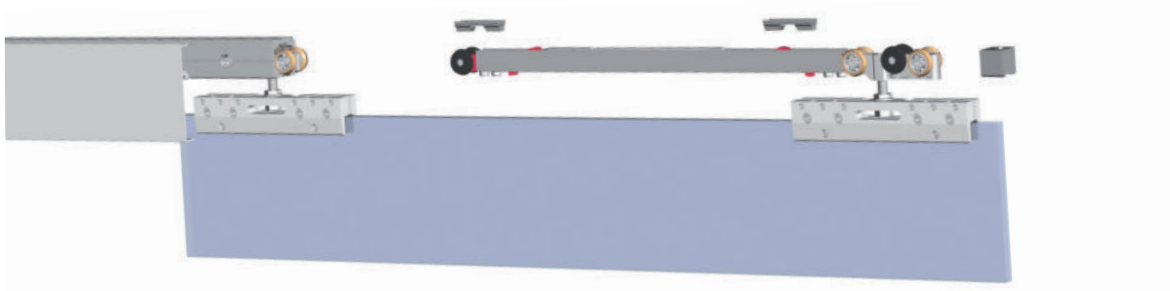

### PINZAS OCULTAS

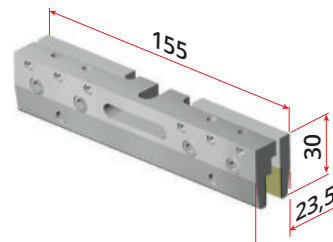
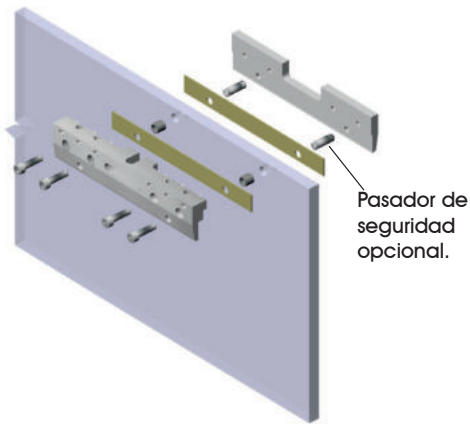

**NO ES NECESARIO HACER MUESCA EN VIDRIO LAMINADO  
PASADOR DE SEGURIDAD SOLO EN VIDRIO TEMPLADO.**

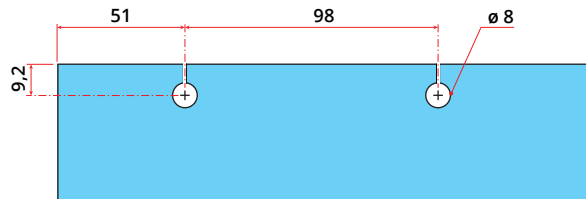

## KIT 3476/028 PARA PUERTA CON BUFFER - 100 Kg

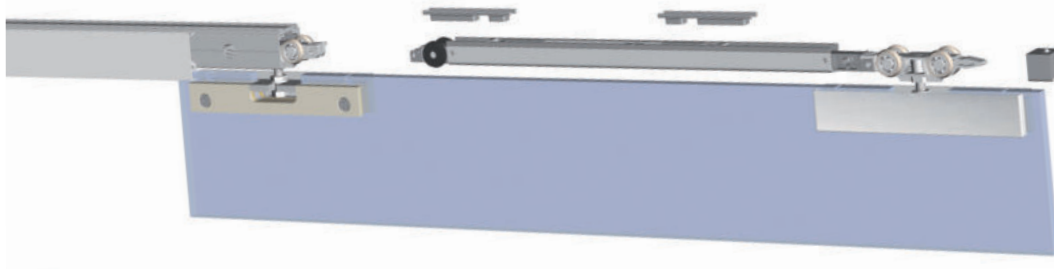

### PINZAS A LA VISTA CON TAPAS EMBELLECEDORAS

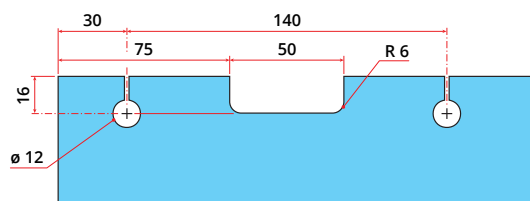
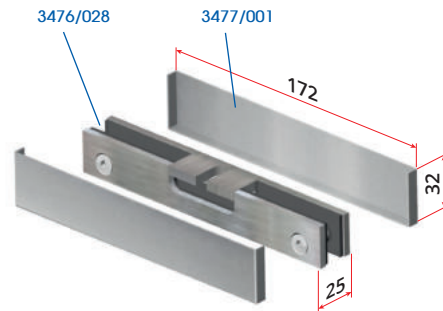
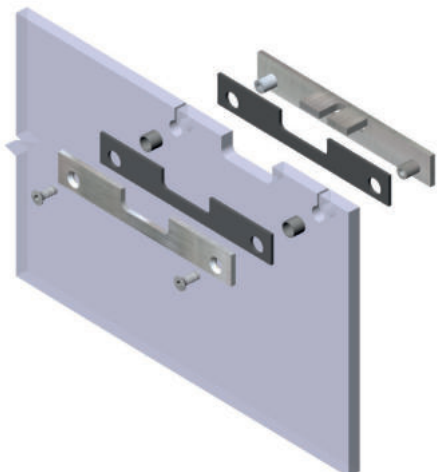

## COTEK - PISA / MONZA

PUERTAS CORREDERA - PORTES COULISSANTES  
SLIDING DOORS - PORTE SCORREVOLI

### SISTEMA EASY-ON

El novedoso sistema de sustitución del buffer permite cambiarlo sin tener que desmontar el carril. Solo hay que mecanizar, previamente, con un fresado el carril o dejar un registro de 5cm antes de su instalación.

Le système de remplacement innovant buffer vous permet de le changer sans avoir à démonter le rail. Vous devez seulement mécaniser, auparavant, avec un fraisage de la voie ou laisser un record de 5cm avant son installation.

The innovative buffer replacement system allows you to change it without having to disassemble the rail. You only have to mechanise, previously, with a milling the lane or leave a record of 5cm before its installation.

L'innovativo sistema di sostituzione del buffer consente di cambiarlo senza dover smontare la guida. Fresare il binario 5 cm nella parte finale o lasciare un registro smontabile di 5 cm.

**A** Registro de 5cm.

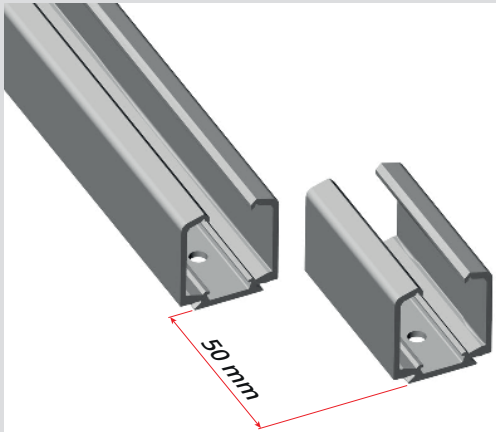

**B** Fresado del carril

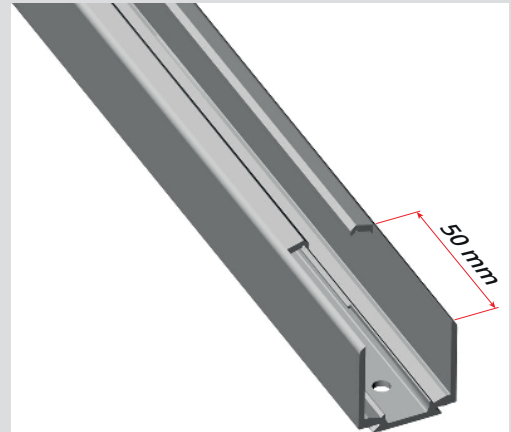

### Cambio de buffer

Fijar el carril con tornillos. Fixez le rail avec des vis.  
Fix the rail with the screws. Fissare il binario con le viti.

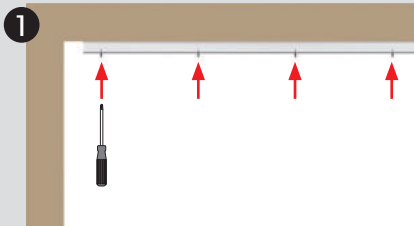

Insérte el tope límite, el activador y el carro. Insérer la butée, l'activateur et le chariot. Inserire il fermo di fine corsa, l'attivatore e il carrello. Insert the stopper, the activator and the carriage.

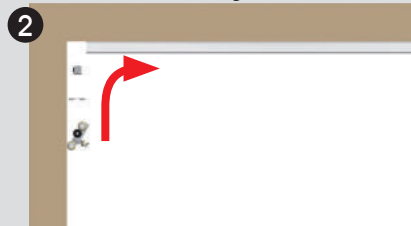

Insérte el buffer. Insérer le système de fermeture en douceur. Insert the soft close system. Insérez le système de fermeture en douceur.



Deslice el buffer. Faites glisser le système de fermeture en douceur. Slide the soft close system. Far scorrere il soft close system.

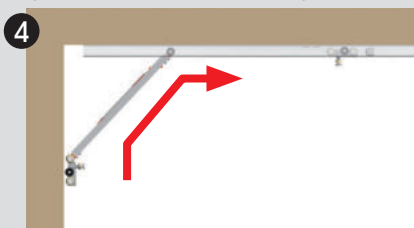

Acabe de insertar el 2º carro. Insérte 2º chariot. Inserire il 2º carrello. Insert the 2nd carriage.

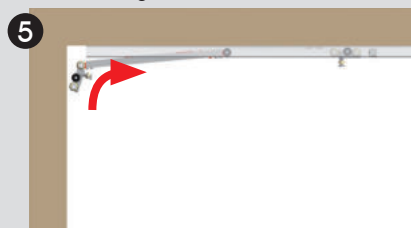

Insertar 2º activador, 2º parada y el terminal. Insérer le 2e activateur, le 2e arrêt et le terminal binaire. Insert 2º activator, 2º stopper and the rail terminal. Insérez le 2º activateur, 2º fermos e il terminale binario.

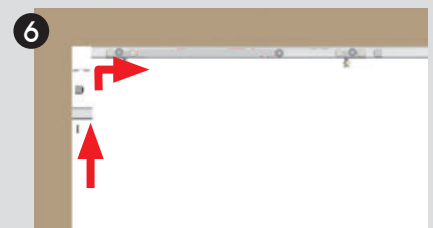

**COTEK - \*RIMINI 80 KG**PUERTAS CORREDERAS CON AMORTIGUADOR - PORTES COULISSANTS AVEC AMORTISSEURS  
SLIDING DOORS WITH DUMPERS- PORTE SCORREVOLI CON AMORTIZZATORI**RIMINI**

- peso max. puerta: 80 kg/puerta
- vidrio 8-10 mm
- con muesca en el vidrio

- pods-limite porte: 80 kg/porte
- verre 8-10 mm
- encoches

- weight max. door: 80 kg/door
- glass 8-10 mm
- cut-out

- peso max. porta: 80 kg/porta
- vetro 8-10 mm
- tacca nel vetro

**PUERTA CORREDERA CON GUIA INVISIBLE**

- Corredera "INVISIBLE", solo necesita un anclaje a la pared que queda oculto detras del perfil superior.
- Apto para paredes de pladur.
- El vidrio descansa sobre los cojinetes inferiores.
- Peso max: 80 kg/puerta
- Vidrio templado: 8-10 mm
- Ancho MIN de cristal 625mm. Ancho MAX de cristal 1200mm.
- Porte coulissante "INVISIBLE", vous seulement besoin d'une ancre au mur, qui se cache derrière le profil supérieur.
- Convient aux murs en plaques de plâtre.
- Le verre repose sur les roulements inférieurs.
- Poids max: 80 kg/porte
- Verre trempé: 8-10 mm
- MIN largeur de verre 625mm. MAX largeur de verre 1200mm.
- "INVISIBLE" door, you only need an anchor to the wall that is hidden behind the upper profile.
- Suitable for plasterboard walls.
- The glass rests on the lower bearings.
- Max weight: 80 kg/door
- Tempered glass: 8-10 mm
- MIN width of glass 625mm. MAX width of glass 1200mm.
- Scorrevole "INVISIBLE", serve solo un supporto al muro nascosto dietro il profilo superiore.
- Adatto per pareti in cartongesso.
- Il vetro riposa sui cuscinetti inferiori.
- Peso max: 80 kg/porta
- Vetro temperato: 8-10 mm
- Larghezza MIN del vetro 625mm. Larghezza MAX del vetro 1200mm.

**RIMINI**  
CORREDERA - COULISSANTS  
SLIDING DOOR - SCORREVOLIALU, M  
ALU, M  
ALL, NAT

01

Al  $\frac{1}{L}$  1.2m €/u

KIT PUERTA INVISIBLE  
KIT DE PORTE INVISIBLE  
INVISIBLE DOOR KIT  
KIT PORTA INVISIBLE  
\*3485/001

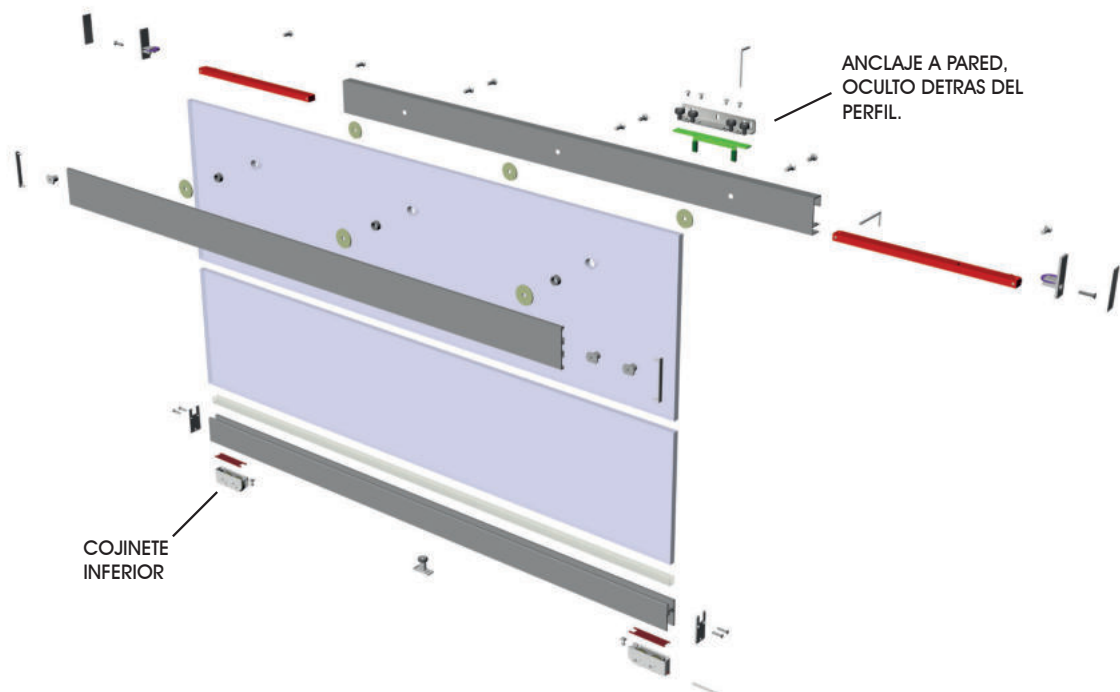
**Componentes del KIT - Composants du KIT - Components of the KIT - Componenti del KIT.**

# COTEK - \*RIMINI 80 KG

PUERTAS CORREDERAS CON AMORTIGUADOR - PORTES COULISSANTS AVEC AMORTISSEURS  
SLIDING DOORS WITH DUMPERS- PORTE SCORREVOLI CON AMORTIZZATORI

Cálculo de las dimensiones del cristal.  
*Calcul des dimensions du verre.*  
*Calculation of the dimensions of glass s.*  
*Calcolo delle dimensioni del vetro*

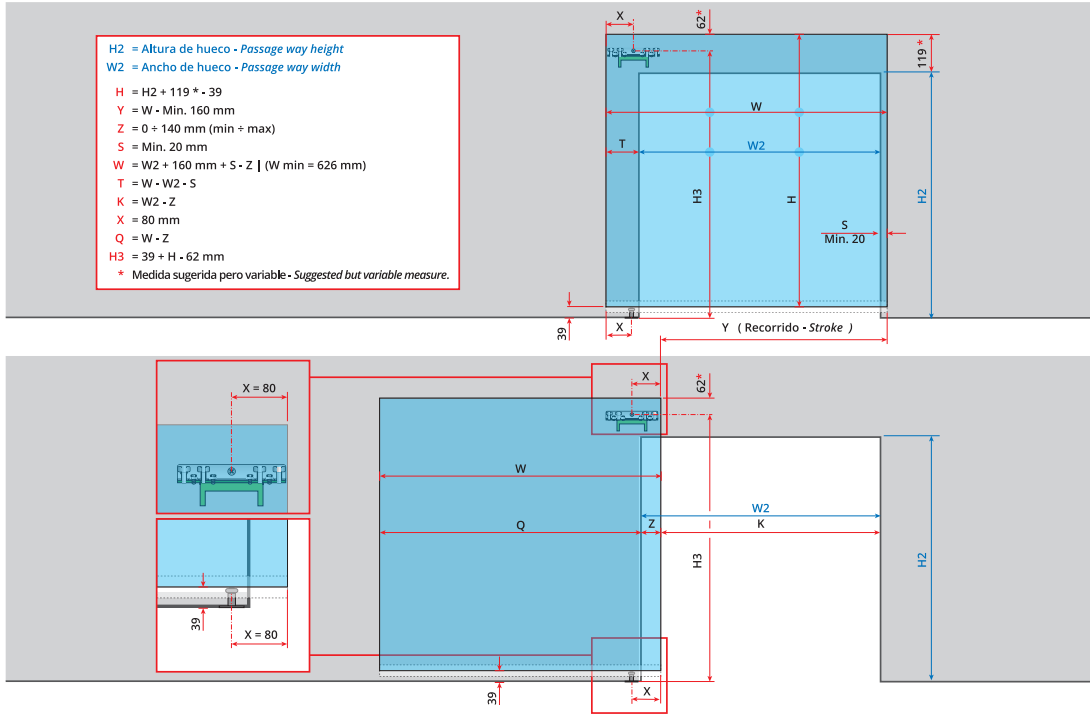

Corte de cristal según medida de puerta.  
*Coupe de verre.*  
*Glass Cutting.*  
*Taglio del vetro.*

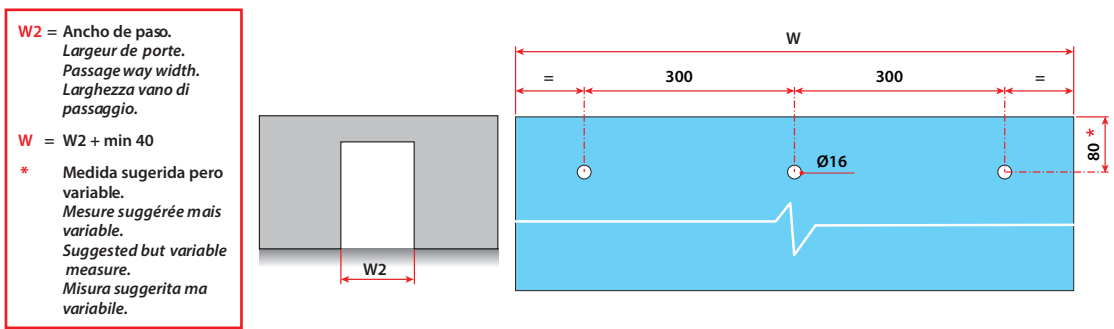

Cortar los elementos a la medida necesaria de puerta.  
*Couper les éléments à la taille nécessaire de la porte.*  
*Cut the elements to the necessary size of door.*  
*Tagliare gli elementi in base alle dimensioni della porta.*

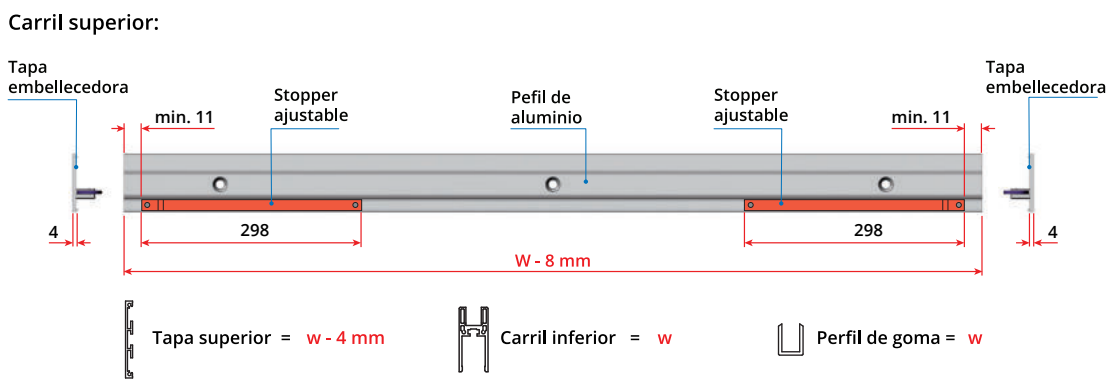

Fijación del cristal con el carril inferior.  
*Fixation du verre avec le rail inférieur.*  
*Fixing the glass with the bottom track.*  
*Fissaggio del vetro con il binario inferiore.*

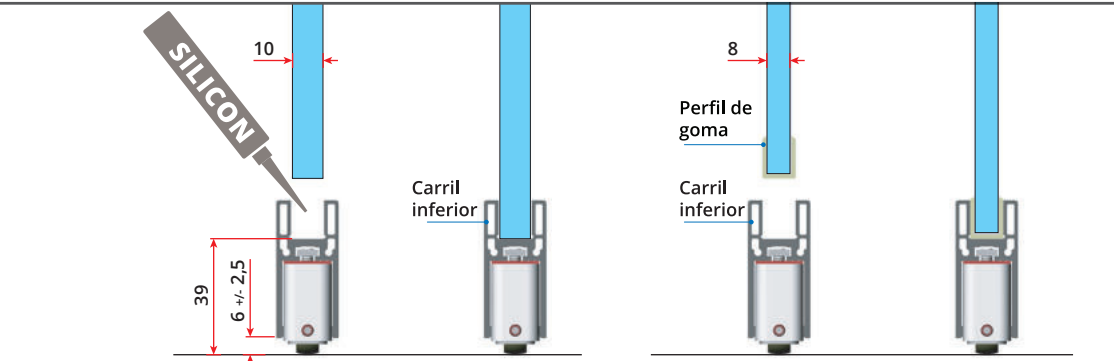

# COTEK - RIMINI 80 KG

PUERTAS CORREDERAS CON AMORTIGUADOR - PORTES COULISSANTS AVEC AMORTISSEURS  
SLIDING DOORS WITH DUMPERS - PORTE SCORREVOLI CON AMORTIZZATORI

## Sistema de tipo A

$W = W2 + 40 \text{ mm}$

- \*Medida sugerida pero variable.
- \*Mesure suggérée mais variable.
- \*Suggested but variable measure.
- \*Misura suggerita ma variabile.

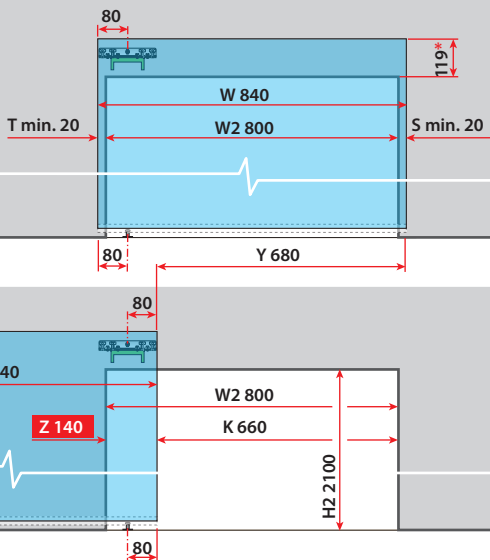

## Posición A

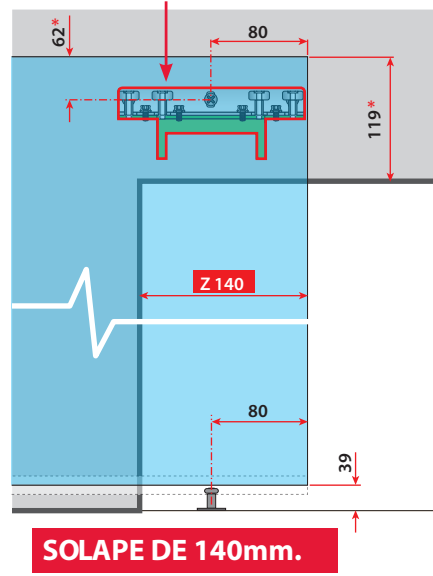

## Sistema de tipo B

$W = W2 + 110 \text{ mm}$

- \*Medida sugerida pero variable.
- \*Mesure suggérée mais variable.
- \*Suggested but variable measure.
- \*Misura suggerita mavariabile.

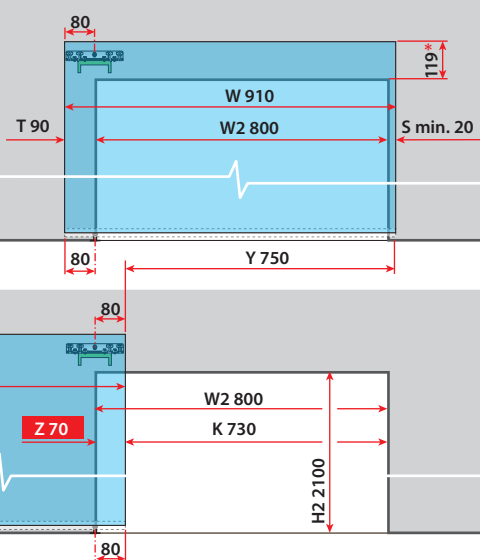

## Posición B

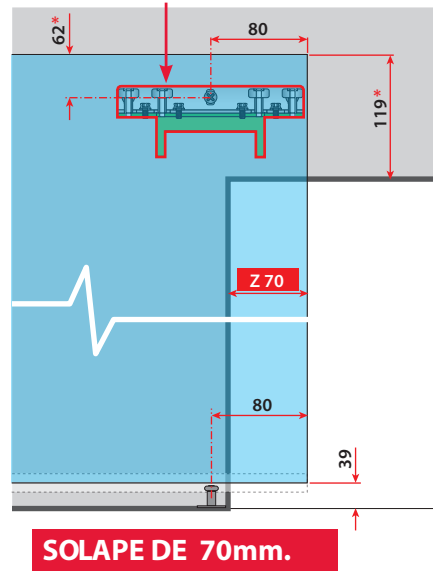

## Sistema de tipo C

$W = W2 + 180 \text{ mm}$

- \*Medida sugerida pero variable.
- \*Mesure suggérée mais variable.
- \*Suggested but variable measure.
- \*Misura suggerita mavariabile.

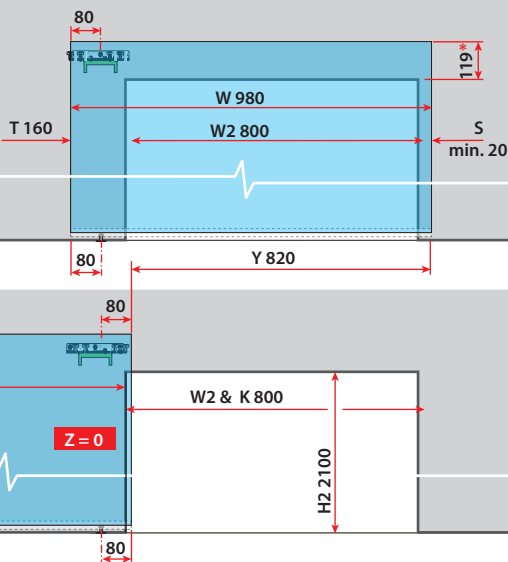

## Posición C

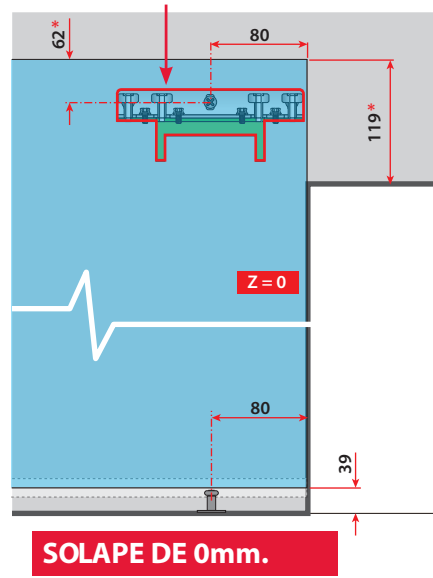



**COTEK - \*VIGO**  
PUERTAS CORREDERA - PORTES COULISSANTES  
SLIDING DOORS - PORTE SCORREVOLI

PL, BR  
ALU, BR  
ALU, BR  
ALL, LUC  
02

**VIGO**

ALUMINIO ACABADO INOX

- HASTA 80 KG POR PUERTA
- VIDRIO DE 8-10 MM
- SOLO MONTAJE A PARED
- SE VENDE EN KIT POR PUERTAS DE 2 M



**COTEK - \*VIGO**  
PUERTAS CORREDERA - PORTES COULISSANTES  
SLIDING DOORS - PORTE SCORREVOLI

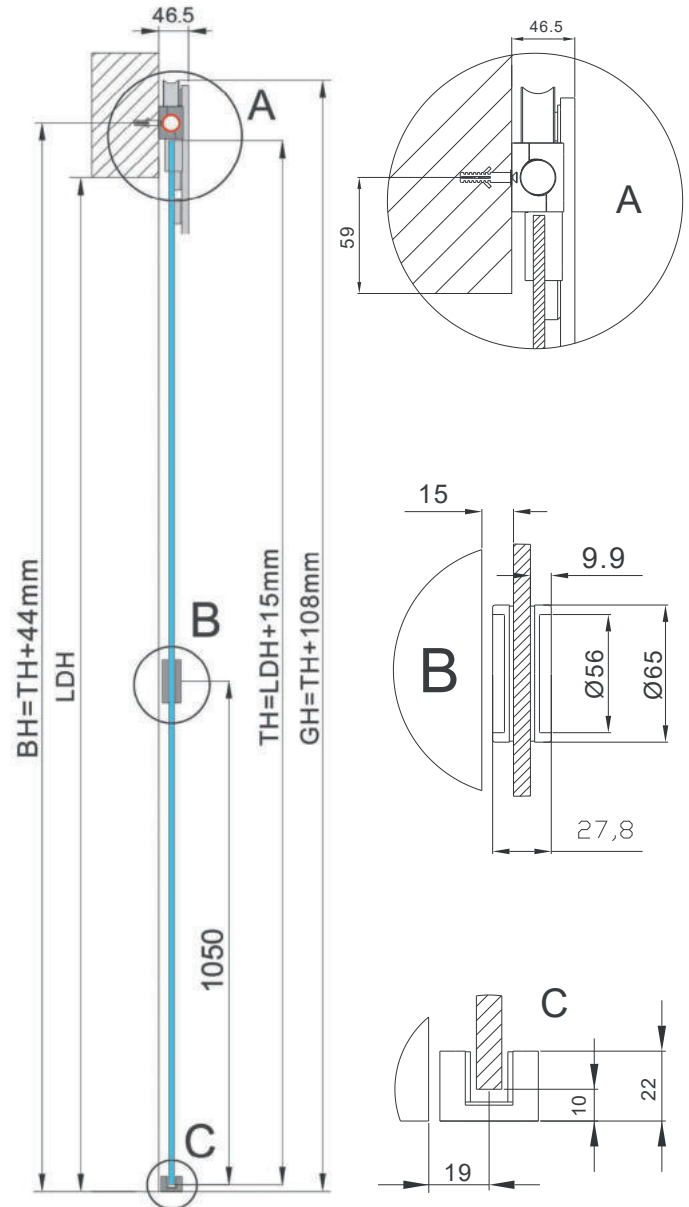

**KIT PUERTA CORREDERA MONTAJE A PARED**  
KIT DE PORTE COULISSANTE FIXÉ AU MUR  
SLIDING DOOR SET WALL MOUNTED  
SET PORTA SCORREVOLE MONTATA A A PARETE  
**\*5393/P38**

- 2 u. **COJINETES**  
CHARLOT - ROLLER - CUSCINETTO
- 2 u. **STOP**  
STOP CHARLOT - STOP ROLLER - STOP CUSCINETTO
- 5 u. **CONEXIÓN TUBO-PARED**  
FIXATION TUBE-MUR - CONNEXION TUBE-WALL - CONNESSIONE TUBO-PARETE
- 1 u. **GUÍA INFERIOR**  
GUIDAGE AU SOL - FLOOR GUIDE - GUIDA A PAVIMENTO
- 1 u. **UÑERO 4207/028** (el tirador de la foto es opcional)  
POIGNEÉ 4207/028 - KNOB 4207/028 - POMO - 4207/028



2 m **TUBO Ø25 mm** 4350/228

TUBE Ø25 mm - TUBO Ø25 mm

2 u. **REMATE FINAL TUBO** 236/008

BOUCHON COULISSE - END-CAP TRACK - COPRITESTA TUBO



€/u



**AGUJEROS PARA EL CRISTAL**

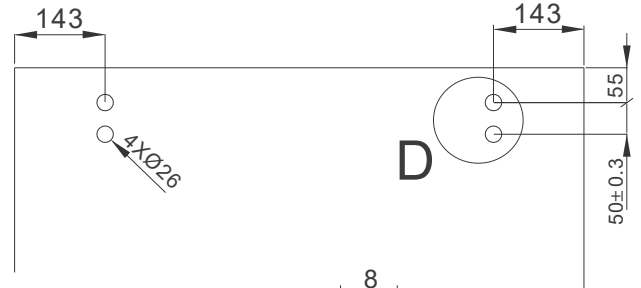

**D**  
Detalle de sección

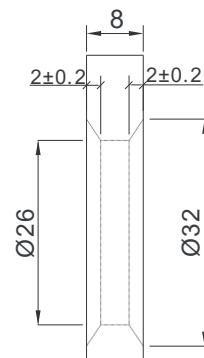



## COTEK - ÍNDEX

### PUERTAS DE PASO - ABATIBLES

#### 1- PREMIUM (HIDRÁULICAS) 115 Selección de herraje de alta gama

- A. **AMSTERDAM** Freno pivotante sin empotrar inox 304  
100kg vidrio 8-12 mm
- B. **MIAMI** Freno pivotante sin empotrar inox 316 150kg  
vidrio 8-12 mm
- C. **BOSTON** Freno pivotante sin empotrar fuerza 7 para  
puertas exteriores inox 316 100kg vidrio 8-12 mm
- D. **PRAGA** Bisagra hidráulica a pared con retención  
inox 304, vidrio 8-10 mm 30 kg/u
- E. **OPORTO** Bisagra hidráulica a pared con retención  
aluminio, vidrio 8-10 mm 20/30 kg/u

#### 2- HIDRÁULICAS / AUTOMÁTICAS 117

#### 3- FRENOS / MARINA / PLINTO / MALAGA 119

#### 4- CANTON PIVOTANTE 121

#### 5- PERFIL PUERTAS / DIVISORIAS 125

#### 6- CERRADURAS 127

#### 7- TIRADORES 129

**SERIE PREMIUM**

# FRENO AMSTERDAM

Freno pivotante sin empotrar

# FRENO MIAMI

Freno pivotante sin empotrar FUERZA 5

**Herraje superior**

- Penture haute
- Top pivoting hinge
- Cerniera superiore pivotante

SET COMPLETO DE HERRAJE Y GIRO SUPERIOR

**Freno hidráulico sin empotrar para interiores**

- Ferme-porte hydraulique sans creusement utilisation en intérieur
- Hydraulic spring floor no digging for indoor use
- Chiudiporta idraulico senza incasso per uno interno

€/u  
**1536/0..**

- 28 22 ON
- ○ ○

€/u  
**1535/0..**

- 28 22 ON
- ○ ○



stop 0°-90°-180°

- ix** Inox 304
- 100 kg/u
- 190X70 mm
- Ancho máximo 100 cm
- 8-12 mm
- Testado 500.000 ciclos

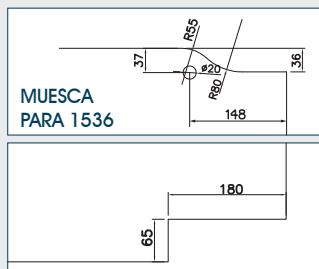
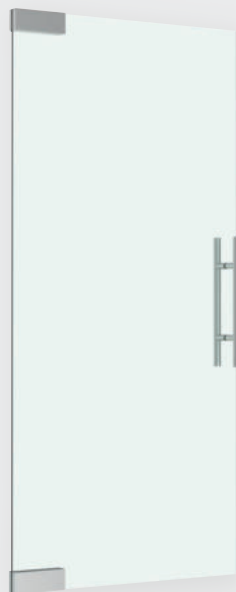

- TESTADO 500.000 CICLOS
- GARANTÍA 3 AÑOS
- TAXA DE REPOSICIÓN DEL 0,5%



€/u  
**5340/0..**

- 28 22 ON
- ○ ○

**Freno pivotante sin empotrar**

- Frein de pivot non intégré
- Non-embedded pivot brake
- Freno a perno non incorporato



€/u  
**5342/0..**

- 28 22 ON
- ○ ○

**Herraje superior (para Miami y Boston)**

- Frein de pivot non intégré
- Non-embedded pivot brake
- Freno a perno non incorporato



€/u  
**5343/0..**

- 28 22
- ○

**Giro superior (para Miami y Boston)**

- Frein de pivot non intégré
- Non-embedded pivot brake
- Freno a perno non incorporato



**ix** Inox 316  
150 kg/u

- 8-15 mm
- 500.000 ciclos

- Ancho máx. 120 cm
- Alto máx. 240 cm

- Resistencia al viento amortiguación hidráulica de alto rendimiento

- ★ 1. Ángulo abierto: 140° doble acción
- 2. Sección de retención de puerta abierta: 90° y 140°-120°
- 3. Dos velocidades ajustables
- Válvula 1: 90°-0°
- Válvula 2: 30°-0°

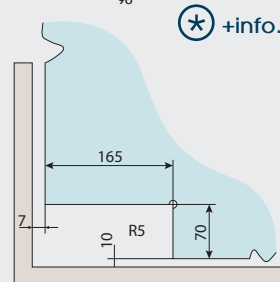
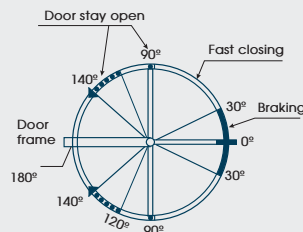
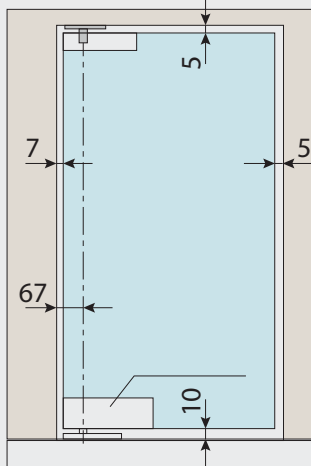

**Serie PREMIUM**

**SERIE PREMIUM**

# FRENO BOSTON

## FUERZA 7, APTO PARA EXTERIORES

Freno pivotante sin empotrar

€/U  
**5341/0..**

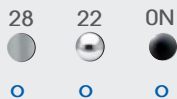

Satinado



Freno pivotante sin empotrar

- Frein de pivot non intégré
- Non-embedded pivot brake
- Freno a perno non incorporato

€/U  
**5342/0..**



Herraje superior (para Miami y Boston)

- Frein de pivot non intégré
- Non-embedded pivot brake
- Freno a perno non incorporato



€/U  
**5343/0..**

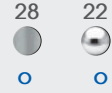

Giro superior (para Miami y Boston)

- Frein de pivot non intégré
- Non-embedded pivot brake
- Freno a perno non incorporato



## FUERZA 7

ix Inox 316

- A prueba de viento fuerte, resistencia de grado 7, seguro y fiable
- Se puede utilizar para exteriores.
- Vida útil ultralarga La garantía de calidad, seguro y duradero.
- Fácil instalación.
- Carga estable. Diseño compacto con gran capacidad de carga.

100 kg/u

8-15 mm

500.000 ciclos

Ancho máx. 100 cm  
Alto máx. 220 cm

1. Ángulo abierto: 120° doble acción
2. Sección de retención de puerta abierta: 90°
3. Dos velocidades ajustables  
Válvula 1: 90°-30°  
Válvula 2: 30°-0°

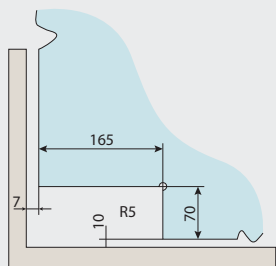
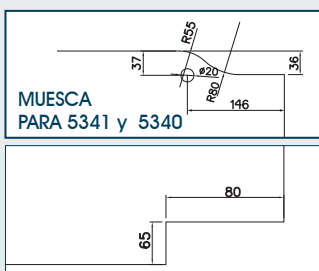

# BISAGRA PRAGA

Bisagra hidráulica a pared con retención

€/set de 2u.

Set 2 bisagras  
**5325/0..**

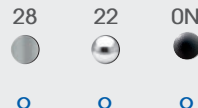

Bisagra hidráulica PARED - VIDRIO

- Penture haute
- Top pivoting hinge
- Cerniera superiore pivotante



ix Inox 304

30 kg/u

8-12 mm

Ancho máx. 1000mm  
Alto máx. 2200mm

50.000 ciclos

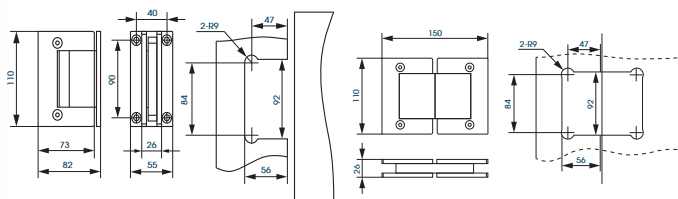

# BISAGRA OPORTO

Bisagra hidráulica a pared con retención

€/U

Derecha  
**1487/D0N**

Izquierda  
**1487/Z0N**

€/U

Derecha  
**1488/D0N**

Izquierda  
**1488/Z0N**

0N 32



Bisagra hidráulica PARED - VIDRIO

- Penture haute
- Top pivoting hinge
- Cerniera superiore pivotante

Bisagra hidráulica VIDRIO - VIDRIO

- Charnière hydraulique
- Hydraulic hinge
- Cerniera idraulica



al Aluminio

8-10 mm

25 kg/u

50.000 ciclos

**Serie PREMIUM**

## COTEK - FRENOS

HERRAJES PARA PUERTAS - QUINCAILLERIE DE PORTE  
DOORS PATCH FITTINGS - ACCESSORI PER PORTE

### RIO HIDRAULICA



BISAGRA PARED-VIDRIO  
HIDRÁULICA REGULABLE  
CHARNIÈRE MUR-VERRE  
HYDRAULIQUE RÉGLABLE  
WALL-GLASS HINGE  
ADJUSTABLE HYDRAULIC  
CERNIERA MURO-VERRO  
IDRAULICA REGOLABILE

1485/022  
1485/028  
1485/00N

- Mides màxima de porta  
850x2100mm  
- Pes màxim per porta  
22.5Kg per us

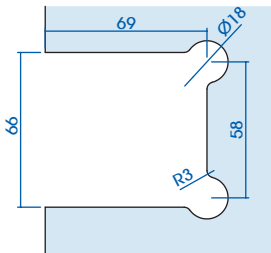

INOX BR	INOX SAT	ZINCADO
INOX POLI	S.S.S.	PL. ZNK
P.S.S.	S.S.S.	ZNK PL.
INOX LUC	INOX SAT	ZINCATO
22	28	34

inox s.s.		Ciclos: 50.000	€/u
	8-12 mm	22,5kg/u	Ancho max. 650mm



## COTEK - HIDRAULICA

HERRAJES PARA PUERTAS - QUINCAILLERIE DE PORTE  
DOORS PATCH FITTINGS - ACCESSORI PER PORTE

### LONDRES

#### BISAGRA PIVOTANTE FRENO HIDRÁULICO REGULABLE SIN EMPOTRAR

*pivotant charnière ferme-porte hydraulique réglable sans creusement*  
*pivoting hinge hydraulic spring floor adjustable no digging*  
*cerniera pivotante chiudiporta idraulico regolabile senza incasso*

Vidrio 8-10-12 mm  
Peso max. 80 kg/puerta  
ancho max. 100 cm  
Para uso interior  
Testada 500.000 ciclos

inox s.s.	0°-25°/25°-70°	100kg/u	€/u
	8-12 mm	<-> max. 1000 mm	
	stop 0°-90°-180°	173X55 mm	



FRENO HIDRAULICO SIN EMPOTRAR  
PARA INTERIORES  
FERME-PORTE HYDRAULIQUE SANS  
CREUSEMENT UTILISATION EN INTERIEUR  
HYDRAULIC SPRING FLOOR NO DIGGING  
FOR INDOOR USE  
CHIUDIPIORTA IDRAULICO  
SENZA INCASSO PER USO INTERNO  
\*1483/0..

inox s.s.	Al		8-12mm	€/u
	∅ 12 mm		173X55 mm	



HERRAJE SUPERIOR  
PENTURE HAUTE  
TOP PIVOTING HINGE  
CERNIERA SUPERIORE PIVOTANTE  
\*1484/0..giro superior



GIRO SUPERIOR ∅ 12 mm  
CRAPAUDINE HAUTE ∅ 12 mm  
CEILING PIVOT ∅ 12 mm  
GIRO SUPERIORE ∅ 12 mm  
1571/022

inox s.s.	∅ 12	€/u
-----------	------	-----

## MALLORCA HIDRAULICA



Regulación fuerza

BISAGRA PARED-VIDRIO  
HIDRÁULICA CON LLAVE PARA  
REGULAR

CHARNIÈRE MUR-VERRE HYDRAULIQUE  
AVEC CLÉ POUR RÉGULIER  
WALL-GLASS HINGE HYDRAULIC  
WITH KEY FOR REGULATE IT  
CERNIERA MURO-VERRO IDRAULICO  
CON CHIAVE PER REGOLARLO

4100/H22

BISAGRA VIDRIO-VIDRIO  
HIDRÁULICA CON LLAVE PARA  
REGULAR

CHARNIÈRE VERRE-VERRE HYDRAULIQUE  
AVEC CLÉ POUR RÉGULIER  
GLASS-GLASS HINGE HYDRAULIC  
WITH KEY FOR REGULATE IT  
CERNIERA VETRO-VERRO IDRAULICO  
CON CHIAVE PER REGOLARLO

4101/H22

BISAGRA PARED-VIDRIO  
DESPLAZADA HIDRÁULICA  
CON LLAVE PARA REGULAR

CHARNIÈRE MUR-VERRE DESPLACÉE  
HYDRAULIQUE AVEC CLÉ POUR RÉGULIER  
WALL-GLASS HINGE HYDRAULIC OFFSET  
WITH KEY FOR REGULATE IT  
CERNIERA MURO-VERRO ALA SPOSTATA  
IDRAULICO CON CHIAVE PER REGOLARLO

4103/H22

Cu		Ciclos: 100.000	€/u
	8-12 mm	20 kg/u	Ancho max. 900mm
	0°-90°-180°		Alto max. 2200mm

lx		Ciclos: 100.000	€/u
	8-12 mm	20 kg/u	Ancho max. 900mm
			Alto max. 2200mm

lx		Ciclos: 100.000	€/u
	8-12 mm	20 kg/u	Ancho max. 900mm
			Alto max. 2200mm

**! NUEVO**

## ATLANTA\*

### BISAGRA PARED CON FRENO HIDRAULICO

*charnière mur ferme-porte hydraulique réglable*  
*wall hinge hydraulic spring floor adjustable*  
*cerniera parete chiudiporta idraulico regolabile*



BISAGRA VIDRIO-VIDRIO  
HIDRAULICA PARA INTERIORES  
FERME-PORTE HYDRAULIQUE  
UTILISATION EN INTERIEUR

HYDRAULIC HINGE  
FOR INDOOR USE  
CERNIERA IDRAULICA  
PER USO INTERNO  
\*1547/022

Vidrio 8-10-12 mm  
Peso max. 80 kg/puerta  
ancho max. 100 cm  
Para uso interior  
Testada 500.000 ciclos

inox s.s.	8-10-12 mm		€/u
	0°-90°-180°	112 x 174 mm	

## COTEK - BISAGRAS

HERRAJES PARA PUERTAS - QUINCAILLERIE DE PORTE  
DOORS PATCH FITTINGS - ACCESSORI PER PORTE

### ZURICH

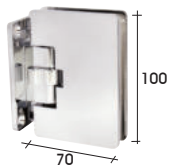

BISAGRA AUTOMÁTICA PARED-VIDRIO  
CHARNIÈRE AUTOMATIQUE MUR-VERRE  
AUTOMATIC HINGE WALL-GLASS  
CERNIERA AUTOMATICA PARETE-VETRO

4135/Z32 zamak

CR. BRILLO	INOX BR	TITANIO	INOX SAT
CHR. POLI	INOX POLI	TITANIO	INOX SAT
CR. ILLC.	P. S.S.	TITANIO	S.S.S.
	INOX ILLC.	TITANIO	INOX SAT
32	22	06	28

Zn		70x100 mm	€/u
	8-12 mm	25 kg/u	0°-90°-180°

○			
---	--	--	--



BISAGRA AUTOMATICA  
VIDRIO-VIDRIO 180°  
CHARNIÈRE AUTOMATIQUE  
VERRE-VERRE 180°

4136/Z32 zamak

Zn		147x100 mm	€/u
	8-12 mm	25 kg/u	0°-90°-180°

○			
---	--	--	--

### SUIZA

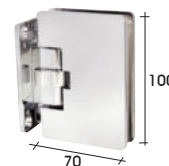

BISAGRA AUTOMÁTICA PARED-VIDRIO  
CHARNIÈRE AUTOMATIQUE MUR-VERRE  
AUTOMATIC HINGE WALL-GLASS  
CERNIERA AUTOMATICA PARETE-VETRO

4152/0.. latón

Cu		70x100 mm	€/u
	8-12 mm	25 kg/u	0°-90°-180°

○		○	
---	--	---	--



BISAGRA AUTOMATICA  
VIDRIO-VIDRIO 180°  
CHARNIÈRE AUTOMATIQUE  
VERRE-VERRE 180°

4153/0.. latón

Cu		147x100 mm	€/u
	8-12 mm	25 kg/u	0°-90°-180°

○		*○	
---	--	----	--

## COTEK - BISAGRAS

HERRAJES PARA PUERTAS - QUINCAILLERIE DE PORTE  
DOORS PATCH FITTINGS - ACCESSORI PER PORTE

CR. BRILLO	CR. MATE	PL. MATE	NEGRO
CHR. POLI	CHR. M	ANOD. M	NOIR
CR. ILLC.	CR. OPAC	ALL. CAN	BLACK
		ALL. NATUR	NERO
32	31	01	0N

### LUGO



BISAGRA PARED-VIDRIO REGULABLE  
CHARNIÈRE MUR-VERRE  
ADJUSTABLE HINGE WALL-GLASS  
CERNIERA PARETE-VETRO REGOLABILE

5310/R32 regulable

Cu		177x55 mm	€/u
	8-10 mm	22 kg/u	0°-90°-180°

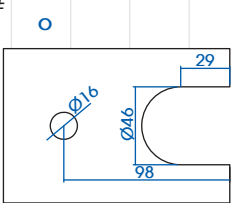

BISAGRA REGULABLE VID-VID. 180°  
CHARNIÈRE RÉGLABLE VER-VER. 180°  
ADJUSTABLE HINGE GLASS-GLASS 180°  
CERNIERA REGOLABILE VET-VET. 180°

5311/R32 regulable

Cu		228x55 mm	€/u
	8-10 mm	22 kg/u	0°-90°-180°

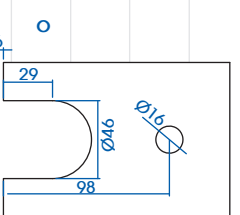

**NUEVO**

### MENORCA



BISAGRA PARED-VIDRIO REGULABLE  
CHARNIÈRE MUR-VERRE  
ADJUSTABLE HINGE WALL-GLASS  
CERNIERA PARETE-VETRO REGOLABILE

4187/R32 regulable

Cu		112x55 mm	€/u
	8-10 mm	22 kg/u	0°-90°-180°

○			
---	--	--	--



BISAGRA REGULABLE VID-VID. 180°  
CHARNIÈRE RÉGLABLE VER-VER. 180°  
ADJUSTABLE HINGE GLASS-GLASS 180°  
CERNIERA REGOLABILE VET-VET. 180°

4186/R32 regulable

Cu		228x55 mm	€/u
	8-10 mm	22 kg/u	0°-90°-180°

○			
---	--	--	--



HERRAJE FIJO 90° PARED-VIDRIO  
FIXATION MUR-VERRE 90°  
BRACKET WALL-GLASS 90°  
MORSETTO PARETE-VETRO 90°

4108/022 inox

4108/Z32 zamak

4108/ZON zamak

	45x45 mm	€/u
	8-12 mm	Ø 16 mm

INOX S.S.	○	
Zn	○	○



HERRAJE FIJO 90° PARED-VIDRIO  
FIXATION MUR-VERRE 90°  
BRACKET WALL-GLASS 90°  
MORSETTO PARETE-VETRO 90°

4199/032

Cu		51x51 mm	€/u
	8-10 mm	Ø 16 mm	

○		
---	--	--



FRENOS IMPORTACIÓN

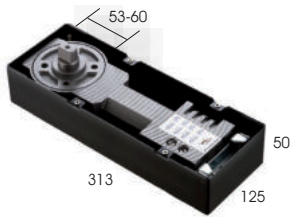

FRENO  
FERME-PORTE  
DOOR CLOSER  
CHIUDIPIORTA

1564/022

leva española  
broches espagnol, Spanish pin, perno spagnolo

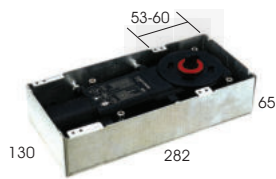

ANCHO MÁXIMO PUERTA: 1 m  
largeur maximale porte  
max. width door  
larghezza massima porta

REGULACIÓN VEL. CIERRE 0°-115°  
régulation de la vitesse de fermeture  
closing action program  
programma velocità chiusura

TAPA INOX BRILLO INCLUIDA  
couvercle en acier inoxydable  
poli inclus  
polish stainless steel cover included  
copertina in inox lucido inclusa

FRENO COMPATIBLE SPEEDY® M25  
FERME-PORTE COMPATIBLE SPEEDY® M25  
DOOR CLOSER COMPATIBLE SPEEDY® M25  
CHIUDIPIORTA COMPATIBLE SPEEDY® M25

\*1562/022 leva española  
broches espagnol, Spanish pin, perno spagnolo

1563/022 leva italiana  
broches italienne, Italian pin, perno italiano

INOX BR	INOX SAT	ZINCADO
INOX POLI	INOX SAT	PL. ZNK
P.S.S.	S.S.S.	ZNK PL.
INOX LUC	INOX SAT	ZINCATO
22	28	34

inox s.s.	<-> max. 1200 mm	€/u
	90°-25° / 25°-0°	135kg/u
	stop 0°-90°-120°	

o 14x8

inox s.s.	<-> max. 1000 mm	€/u
	115°-25° / 25°-0°	120kg/u
	stop 0°-90°-180°	

\*o 14x8

o 116x16

COTEK - PLINTO

HERRAJES PARA PUERTAS - QUINCAILLERIE DE PORTE  
DOORS PATCH FITTINGS - ACCESSORI PER PORTE

INOX BR	INOX SAT	ZINCADO
INOX POLI	INOX SAT	PL. ZNK
P.S.S.	S.S.S.	ZNK PL.
INOX LUC	INOX SAT	ZINCATO
22	28	34

inox s.s.	10-15mm	100 kg	€/u
Al		1200x68x33	

PLINTO

PLINTO COMPATIBLE CON SERIE "MARINA"  
SUPPORT-RAIL PORTE COMPATIBLE AVEC LA SÉRIE "MARINA"  
DOOR RAIL COMPATIBLE WITH "MARINA " SERIES  
SUPPORTO-BINARIO COMPATIBILE CON SERIE "MARINA"

PLINTO SUPERIOR PARA GIRO SUPERIOR Ø 12 mm  
PENTURE HAUTE POUR CRAPAUDINE HAUTE Ø 12 mm  
TOP PIVOTING POLE FOR CEILING PIVOT Ø 12 mm  
CERNIERA INFERIORE PIVOTANTE PER GIRO SUPERIORE Ø 12 mm  
1552/022



o Ø 12

PLINTO INFERIOR LEVA ITALIANA  
PENTURE BASSE BROCHES ITALIENNE  
BOTTOM PIVOTING POLE ITALIAN PIN  
CERNIERA INFERIORE PIVOTANTE PERNO ITALIANO  
1553/022



o 116x16

PLINTO INFERIOR LEVA ITALIANA Y CERRADURA  
PENTURE BASSE BROCHES ITALIENNE ET SERRURE  
BOTTOM PIVOTING POLE ITALIAN PIN WITH LOCK  
CERNIERA INFERIORE PIVOTANTE PERNO ITALIANO CON SERRATURA  
1554/022



o 116x16

PERFIL PARA LATERAL FIJO  
PROFIL DE CÔTÉ FIXE  
FIXED GLASS PROFILE  
PROFILO LATERALE FISSO  
1555/022



inox s.s.	10-15mm	€/u
Al		1300x68x33

o



GIRO INFERIOR LEVA ITALIANA  
CRAPAUDINE BASSE BROCHES ITALIENNE  
FLOOR PIVOT ITALIAN PIN  
GIRO INFERIORE PERNO ITALIANO  
4396/028

inox s.s.	116x16	€/u
-----------	--------	-----

o



# COTEK - MALAGA

HERRAJES PARA PUERTAS - QUINCAILLERIE DE PORTE  
DOORS PATCH FITTINGS - ACCESSORI PER PORTE

## MALAGA



HERRAJE SUPERIOR  
PENTURE HAUTE  
TOP PIVOT POLE  
CERNIERA SUPERIORE  
**\*5568/028**

CP. BRILLO	CP. MATE	INOX. BR.	INOX. SAT.
CH-R, POLI	CH-R, M	INOX. POLI	INOX. SAT.
BR. CH-R	M. CH-R	P. S. S.	S. S. S.
CP. ILLC.	CP. OPAC	INOX. ILLC.	INOX. SAT.

inox s.s.	10mm	70kg/u	€ / u
-----------	------	--------	-------



HERRAJE INFERIOR  
REGULABLE LEVA ESPAÑOLA  
PENTURE BASSE RÉGLABLE  
BROCHES ESPAGNOL  
BOTTOM PIVOT POLE  
ADJUSTABLE SPANISH PIN  
GIRO INFERIORE REGOLABILE  
PERNO SPAGNOLO  
**\*5567/028**

inox s.s.	10 mm	70kg/u	€ / u
14x8			



GIRO SUPERIOR Ø 6 mm  
CRAPAUDINE HAUTE Ø 6 mm  
CEILING PIVOT Ø 6 mm  
GIRO SUPERIORE Ø 6 mm  
**\*5571/028**

inox s.s.	Ø 15	€ / u
-----------	------	-------



GIRO SUPERIOR VIDRIO FIJO  
SUPPORT HAUTE VERRE FIXE+PIVOT  
FIXED GLASS UPPER SUPPORT+PIVOT  
SUPPORTO A VETRO FISSO+GIRO SUP.  
**\*5572/028**

inox s.s.	10-12mm	€ / u
-----------	---------	-------



GIRO SUPERIOR 2 VIDRIOS FIJOS  
SUPPORT HAUTE 2 VERRES FIXES+PIVOT  
2 FIXED GLASSES UPPER SUPPORT+PIVOT  
SUPPORTO 2 VETRI FISSI+GIRO SUP.  
**\*5576/028**

inox s.s.	10 mm	€ / u
-----------	-------	-------

## ACCESORIOS COMUNES



TOPE PUERTA VIDRIO FISSO  
ARRETES DE PORTE VERRE FIXE  
DOOR STOPPER FIXED GLASS  
STOP PORTA A VETRO FISSO  
**\*4388/028**

inox s.s.	10-12mm	€ / u
Ø 26 mm	∠ Ø 32 mm	



TOPE PUERTA A PARED Y TECHO  
ARRETES DE PORTE MUR O PLAFOND  
DOOR STOPPER WALL OR CEILING  
STOP PORTA A TETTO O PARETE  
**\*4389/028**

inox s.s.	€ / u
-----------	-------



TOPE PUERTA SUELO  
ARRETES DE PORTE DU SOL  
FLOOR DOOR STOPPER  
STOP PORTA A PAVIMENTO  
**\*1593/0..**

inox s.s.	€ / u
-----------	-------



TOPE PUERTA SUELO  
ARRETES DE PORTE DU SOL  
FLOOR DOOR STOPPER  
STOP PORTA A PAVIMENTO  
**1599/0..**

inox s.s.	€ / u
-----------	-------

**! NUEVO**

# COTEK - MARINA

HERRAJES PARA PUERTAS - QUINCAILLERIE DE PORTE  
DOORS PATCH FITTINGS - ACCESSORI PER PORTE

## MARINA



GIRO SUPERIOR Ø 12 mm  
CRAPAUDINE HAUTE Ø 12 mm  
CEILING PIVOT Ø 12 mm  
GIRO SUPERIORE Ø 12 mm  
**1571/022**

INOX. BR.	INOX. SAT.	ZINCADO
INOX. POLI	INOX. SAT.	PL. ZNK
P. S. S.	S. S. S.	ZNK PL.
INOX. ILLC.	INOX. SAT.	ZNCATO

inox s.s.	Ø 12	€ / u
-----------	------	-------



GIRO SUPERIOR VIDRIO FIJO  
SUPPORT HAUTE VERRE FIXE+PIVOT  
FIXED GLASS UPPER SUPPORT+PIVOT  
SUPPORTO A VETRO FISSO+GIRO SUP.  
**1568/022**

inox s.s.	Al	10-12mm	€ / u
Ø 12 mm			

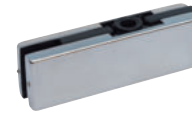

HERRAJE SUPERIOR  
PENTURE HAUTE  
TOP PIVOTING HINGE  
CERNIERA SUPERIORE PIVOTANTE  
**\*1572/0..**

inox s.s.	Al	10-12mm	€ / u
Ø 12 mm			

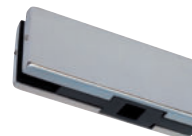

HERRAJE INFERIOR  
PENTURE BASSE  
BOTTOM PIVOT HINGE  
CERNIERA INFERIORE PIVOTANTE  
**1573/022** leva italiana  
broches italienne, Italian pin, perno italiano  
**\*1567/022** leva española  
broches espagnol, Spanish pin, perno spagnolo

inox s.s.	Al	10-12mm	€ / u
60 kg			



GIRO SUPERIOR 2 VIDRIOS FIJOS  
SUPPORT HAUTE 2 VERRES FIXES+PIVOT  
2 FIXED GLASSES UPPER SUPPORT+PIVOT  
SUPPORTO 2 VETRI FISSI+GIRO SUP.  
**1575/022**

inox s.s.	Al	10-12mm	€ / u
Ø 12 mm			



GIRO SUPERIOR PARED Y VIDRIO FIJO  
SUPPORT HAUTE VERRE FIXE ET MUR  
+PIVOT  
FIXED GLASSES AND WALL UPPER  
SUPPORT+PIVOT  
SUPPORTO A VETRO FISSO E  
PARETE+GIRO SUP.  
**1577/022**

inox s.s.	Al	10-12mm	€ / u
Ø 12 mm			



GIRO SUPERIOR 2 VIDRIOS FIJOS  
SUPPORT HAUTE 2 VERRES FIXES  
2 FIXED GLASSES UPPER SUPPORT  
SUPPORTO 2 VETRI FISSI  
**1576/022**

inox s.s.	Al	10-12mm	€ / u
-----------	----	---------	-------



CERRADURA ESQUINA INFERIOR  
SERRURE COIN INFÉRIEUR  
BOTTOM CORNER LOCK  
SERRATURA ANGOLO INFERIORE  
**1569/022**

inox s.s.	10-12mm	€ / u
-----------	---------	-------



GIRO INFERIOR LEVA ITALIANA  
CRAPAUDINE BASSE BROCHES ITALIENNE  
FLOOR PIVOT ITALIAN PIN  
GIRO INFERIORE PERNO ITALIANO  
**4396/028**

inox s.s.	16x16	€ / u
-----------	-------	-------

## PUERTAS DE PASO - MARCO PIVOTANTE

### CANTÓN MARCO PIVOTANTE



**ELIGE EL RAL  
QUE QUIERAS**

PERSONALIZA  
LOS ESPACIOS  
CON LOS COLORES

## PUERTAS DE PASO - MARCO PIVOTANTE



# PUERTAS DE PASO - MARCO PIVOTANTE

## DATOS GENERALES

### PESO



80 Kg max por hoja

### CARACTERÍSTICAS

Deslizamiento suave  
Distintas opciones de herrajes.  
Posibilidad de crear una estructura japonesa personalizada.

## SECCIONES Y MEDIDAS PERFILES Y VIDRIO

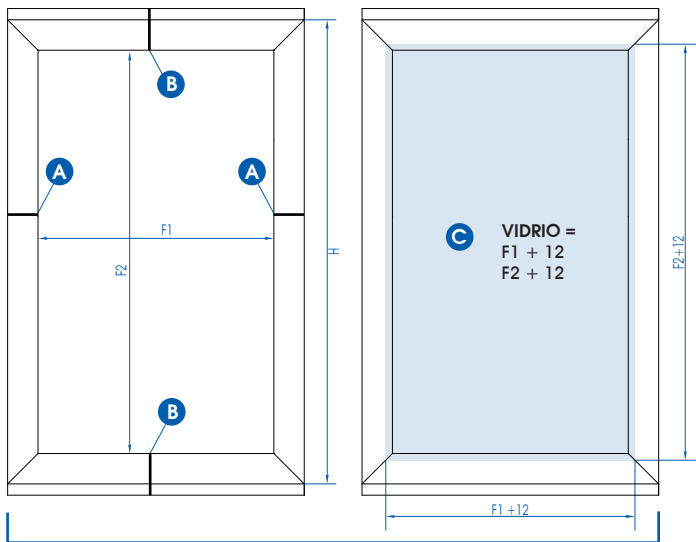
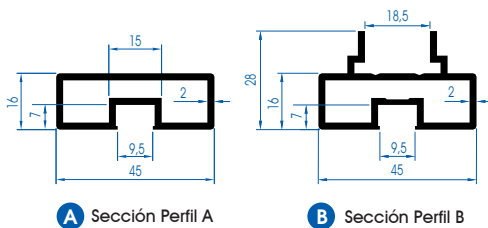

PERFILES PARA SISTEMAS: 5219 +5221 O 5220

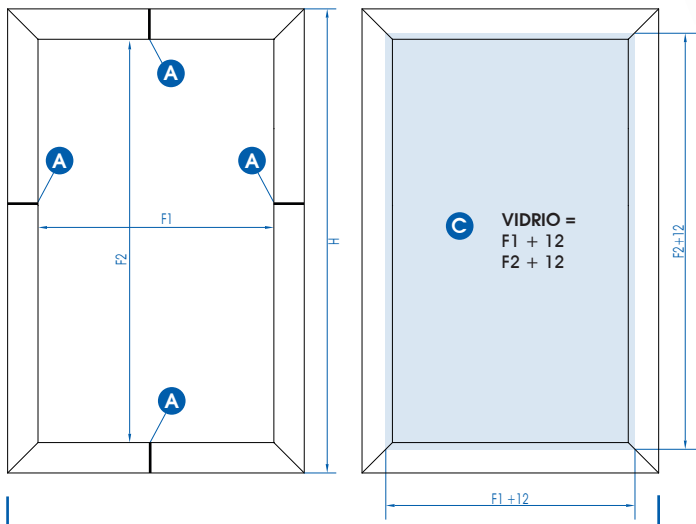

PERFILES PARA SISTEMAS: 5224 , 5223, 5225, 5228, 5229

## PERFLERÍA PUERTA

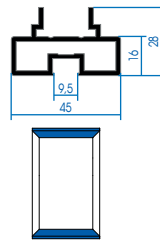

PERFIL INFERIOR Y SUPERIOR (MARCO)  
PROFIL DE CADRE SUPÉRIEUR ET INFÉRIEUR  
UPPER AND BOTTOM FRAME PROFILE  
PROFILO SUPERIORE E INFERIORE CORNICE  
5205/20.

Al 2 m €/u

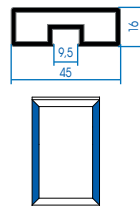

PERFIL LATERAL (MARCO)  
PROFIL DE CADRE LATÉRAL  
LATERAL FRAME PROFILE  
PROFILO LATERALE CORNICE  
5206/30.

Al 3 m €/u



ESQUADRA UNIÓN PERFILES  
SUPPORT POUR ASSEMBLER DES PROFILS  
BRACKET FOR JOINING PROFILES  
GIUNTO UNIONE PROFILI  
5207/000

Al €/u



GALGA ESCUADRA / MECANIZACIÓN PERFL  
JAUGE CARRÉE  
BRACKET GAUGE  
CALIBRO SQUADRA  
5207/010

Plc €/u

PLÁSTICO  
PLASTIC  
PLASTICA  
09

## PERFIL MARCO PUERTA

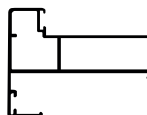

PERFIL MARCO  
EMBELLECEDOR CIERRE  
PROFIL DE CADRE DE FINITION  
CLOSING TRIM FRAME PROFILE  
PROFILO DEL TELAIO DI CHIUSURA  
5224/20.

Al 2 m 5227 €/u



JUNTA MARCO PUERTA.  
JOINT DE CADRE DE PORTE  
DOOR FRAME GASKET  
GUARNIZIONE TELAIO PORTA  
5224/109

PVC €/u



ESCUADRAS PARA PERFL 5224  
ANGLES POUR PROFIL 5224  
ANGLES FOR PROFILE 5224  
ANGOLI PER PROFILO 5224  
5227/000

Al 2 m 5224 €/u

## PERFIL PARA PUERTA JAPONESA



PERFIL ALUMINIO PARA CRISTAL-PUERTA DE PANEL JAPONÉS  
PROFILÉ EN ALUMINIUM POUR LE VERRE DANS LA PORTE À PANNEAU JAPONAIS.  
ALUMINIUM PROFILE FOR GLASS IN JAPANESE PANEL DOOR.  
PROFILO IN ALLUMINIO PER VETRO IN ANTA A PANNELLO GIAPPONESE.  
5127/30.

Al 3 m 5209 €/u  
15,6x10,1mm

Ver instrucciones de montaje.

# PUERTAS DE PASO - MARCO PIVOTANTE

## KITS PARA MARCO PIVOTANTE

NEGRO NOIR BLACK NERO	INOX SAT. INOX SAT. S.S.S INOX SAT.
0N	28

BRUTO RAW GREZZO	NEGRO NOIR BLACK NERO
09	0N



**PIVOTE INFERIOR CON RODAMIENTO TIPO "DORMA"**  
PIVOT INFÉRIEUR AVEC ROULEMENT DE TYPE "DORMA"  
LOWER PIVOT WITH "DORMA" TYPE BEARING  
PERNO INFERIORE CON CUSCINETTO DI TIPO "DORMA"  
**5219/028**



**HERRAJES PARA PIVOTANTE TIPO "DORMA"**  
RACCORDS POUR PIVOT TYPE "DORMA"  
FITTINGS FOR PIVOT, DORMA TYPE  
RACCORDI PER PERNO TIPO "DORMA"  
**5221/028**



**KIT FRENO DE AIRE PARA SUELO**  
KIT DE FREIN PNEUMATIQUE AU SOL  
AIR FLOOR SPRING KIT  
KIT FRENO PNEUMATICO A PAVIMENTO  
**5220/028**

lx		€/u
----	--	-----

lx	70kg	€/u
----	------	-----

## BISAGRAS PARA MARCO (PUERTA)



**BISAGRA PIVOTANTE OCULTA**  
CHARNIÈRE À PIVOT DISSIMULÉE  
CONCEALED PIVOT HINGE  
CERNIERA A BILICO NASCOSTA  
**5224/028**

ln	5224	€/u
	60kg	



**BISAGRAS PARA PUERTA BATIENTE**  
CHARNIÈRES POUR PORTE PIVOTANTE  
HINGES FOR PIVOT DOOR  
CERNIERE PER PORTA A BILICO  
**5223/00N**

Al	5224	€/u
	40kg	

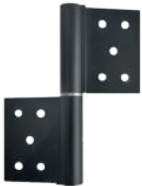

**BISAGRAS PARA PUERTA BATIENTE**  
CHARNIÈRES POUR PORTE PIVOTANTE  
HINGES FOR PIVOT DOOR  
CERNIERE PER PORTA A BILICO  
**5225/D0N**  
**5225/Z0N**

Al	5224	€/u
	80kg	

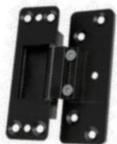

**BISAGRAS PARA PUERTA BATIENTE**  
CHARNIÈRES POUR PORTE PIVOTANTE  
HINGES FOR PIVOT DOOR  
CERNIERE PER PORTA A BILICO  
**5229/00N**

Al	5224	€/u
	40kg	



**BISAGRAS PARA PUERTA BATIENTE**  
CHARNIÈRES POUR PORTE PIVOTANTE  
HINGES FOR PIVOT DOOR  
CERNIERE PER PORTA A BILICO  
**5228/00N**

Inox	5224	€/u
	80kg	



**ANCLAJE PARA MARCO DE PUERTA FIJA**  
ANCRAGE DE CADRE DE PORTE FIXE  
FIXED DOOR FRAME ANCHOR  
ANCORAGGIO TELAI PORTA FISSO  
**5203/T00**

lx		€/u
----	--	-----



lx		€/u
----	--	-----

## PUERTA PIVOTANTE CON FRENO AIRE

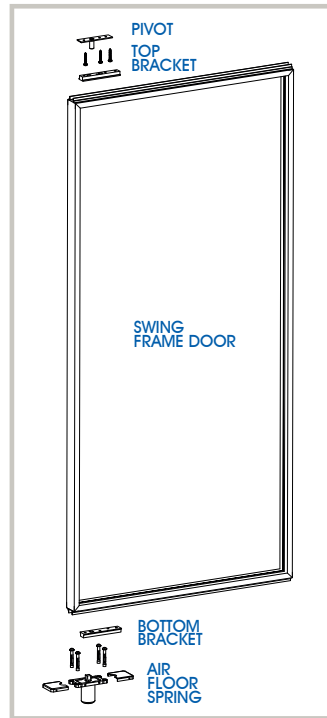

## PUERTA PIVOTANTE CON TEJUELO

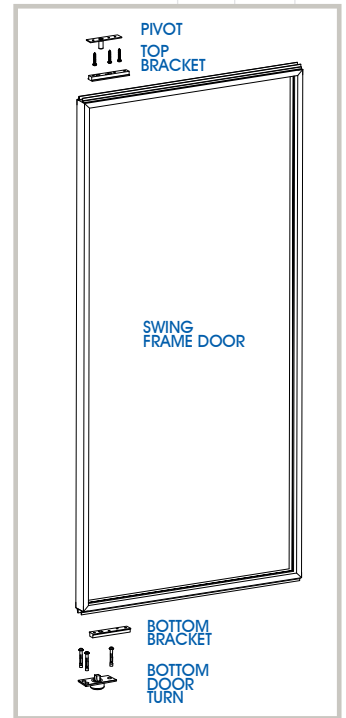

## CINTA ADHESIVA VIDRIO



**CINTA ADHESIVA VIDRIO**  
RUBAN ADHÉSIF DOUBLE FACE EN VERRE  
GLASS DOUBLE SIDED TAPE  
NASTRO BIADESIVO VETRO  
**5209/109**  
**5209/009** ROLLO DE 33M

Pla		€/m
-----	--	-----

## CERRADURAS

Al	8 mm	75x50	€/u
----	------	-------	-----

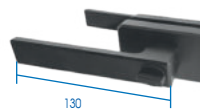

**CERRADURA CON MANETA Y CONTRACERRADURA A PARED (CON CONDENA)**  
SERRURE AVEC POIGNÉE ET GÂICHE MUR (AVEC CLÉ)  
DOOR LOCK WITH HANDLE AND STRIKE PLATE (WITH KEY)  
SERRATURA CON MANIGLIA E CONTOSERRATURA MURO (CON CHIAVE)  
**5218/00N**



**CERRADURA CON MANETA Y CONTRACERRADURA A PARED (CON LLAVE)**  
SERRURE AVEC POIGNÉE ET GÂICHE MUR (AVEC CLÉ)  
DOOR LOCK WITH HANDLE AND STRIKE PLATE (WITH KEY)  
SERRATURA CON MANIGLIA E CONTOSERRATURA MURO (CON CHIAVE)  
**5217/00N**

Al	8 mm	75x50	€/u
----	------	-------	-----

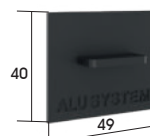

**TAPETA EMBELLECEDORA**  
PROFILÉ DE FINITION "L"  
"L" FINISHING PROFILE  
PROFILO DI FINITURA A "L"  
**85205/00.**

Pl	40x10x0,8mm	€/m
----	-------------	-----

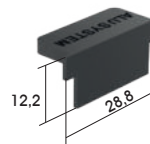

**TAPETA EMBELLECEDORA**  
PROFILÉ DE FINITION "L"  
"L" FINISHING PROFILE  
PROFILO DI FINITURA A "L"  
**85203/00.**

Pl	40x10x0,8mm	€/m
----	-------------	-----



# COTEK - DIVISORIAS

HERRAJES PARA PUERTAS - QUINCAILLERIE DE PORTE  
DOORS PATCH FITTINGS - ACCESSORI PER PORTE

PL. MATE ANOD. M AN. CAN. ALL. NATUR.	NEGRO NOIR BLACK NERO	PLÁSTICO PLASTIQUE PLASTIC PLASTICA
01	0N	09



PERFILERÍA PARA DIVISORIAS DE VIDRIO  
PROFILS POUR CLOISONS EN VERRE  
PROFILES FOR GLASS PARTITIONS  
PROFILI PER PARTIZIONI IN VETRO  
**5580/301**

Al	10-12mm	€/u

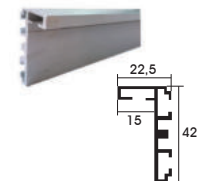

PERFIL BASTIDOR  
PROFILS DE CADRES DE PORTE  
DOOR FRAME PROFILES  
PROFILI PER TELAIO PORTE  
**5581/3..**

Al		€/u



JUNTA MARCO PUERTA  
JOINT DE CADRE DE PORTE  
DOOR FRAME GASKET  
GUARNIZIONE TELAIO PORTA  
**5582/109**

PVC	Rollo 6 Metros	€/u



ESCUADRAS PARA MARCO DE PUERTA  
CARRÉS POUR CADRE DE PORTE  
SQUARES FOR DOOR FRAME  
SQUADRE PER TELAIO PORTA  
**5583/000**

Al		€/u

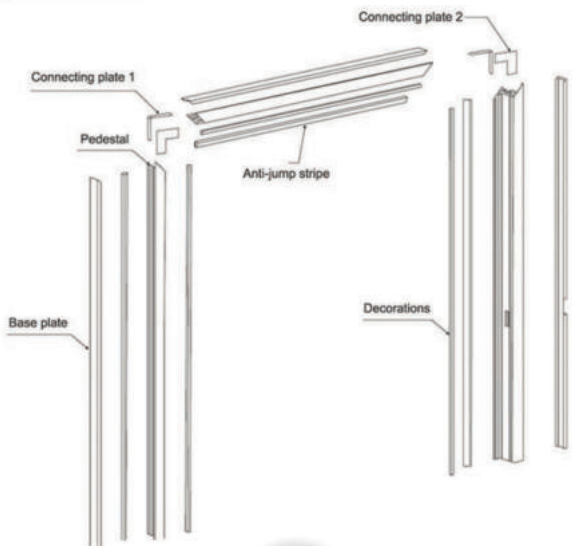

**! NUEVO**

# COTEK - BISAGRAS

HERRAJES PARA PUERTAS - QUINCAILLERIE DE PORTE  
DOORS PATCH FITTINGS - ACCESSORI PER PORTE

CRMATE CHR. M MCHR CROPAC	CR. BRILLO CHR. POLI BR. CHR CR. ILC.	NEGRO NOIR BLACK NERO
31	32	0N

## LYON



BISAGRA PARED-VIDRIO  
CHARNIÈRE MUR-VERRE  
HINGE WALL-GLASS  
CERNIERA PARETE-VERTO  
**4154/0..**

Zn	17,5 kg/u	97x45 mm	€/u
		8-10 mm	0°-90°
			2Ø15 mm



BISAGRA LYON - NEGRO MATE  
**4154/00N**

**! NUEVO**

## VIENA



BISAGRA PARED-VIDRIO  
CHARNIÈRE MUR-VERRE  
HINGE WALL-GLASS  
CERNIERA PARETE-VERTO  
**\*1478/0..**

Al	25 kg/u	0°-90°	84x46	€/u
			8-10 mm	2Ø12 mm

PL. MATE ANOD. M AN. CAN. ALL. NATUR.
01

## GALICIA



BISAGRA PARED-VIDRIO  
CHARNIÈRE MUR-VERRE  
HINGE WALL-GLASS  
CERNIERA PARETE-VERTO  
**4194/001**

Al	25 kg/u	0°-90°	100X50	€/u
			8-10 mm	2Ø16 mm



**4194/00N**

**! NUEVO**

## \*BONN



BISAGRA PARED-VIDRIO  
CHARNIÈRE MUR-VERRE  
HINGE WALL-GLASS  
CERNIERA PARETE-VERTO  
**\*4148/028** der.  
droite/right/destra  
**\*4149/028** izq.  
gauche/left/sinistra

inox s.s.	30 kg/u	131x43 mm	€/u
		10-12 mm	0°-90°
			2 x Ø 16 mm

INOX SAT INOX SAT S.S.S. INOX SAT
28

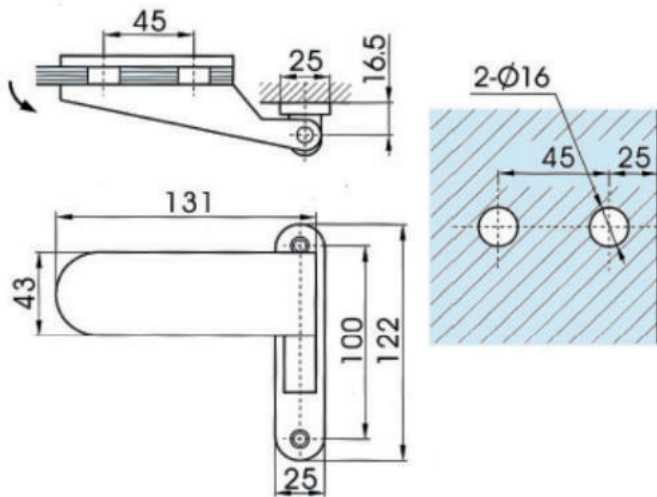

COPIAR MIDES I DISENY CATALOGO TECNICO

# COTEK

HERRAJES ARQUITECTURA - ACCESSOIRES ARCHITECTURE  
ARCHITECTURE HARDWARE - ACCESSORI ARCHITETTURA

## HERRAJES FIJOS



**HERRAJE FIJO 90° PARED-VIDRIO**  
FIXATION MUR-VERRE 90°  
BRACKET WALL-GLASS 90°  
MORSETTO PARETE-VERRO 90°  
**4095/032**

CR, BRILLO	INOX BR	INOX SAT	NEGRO
CH-P, POLI	INOX POJ	INOX SAT	NOIR
BR, CH-P	P.S.S.	S.S.S.	BLACK
CR, LUC.	INOX LLC	INOX SAT	NERO
<b>32</b>	<b>22</b>	<b>28</b>	<b>0N</b>

Cu	inox s.s.	45x45 mm	€/u
6-12 mm		∅ 14 mm	

○



**HERRAJE FIJO 90° VIDRIO-VIDRIO**  
FIXATION VERRE-VERRE 90°  
BRACKET GLASS-GLASS 90°  
MORSETTO VETRO-VETRO 90°  
**4096/032**  
**\*4096/022**

Cu	inox s.s.	45x45 mm	€/u
6-12 mm		2x ∅ 14 mm	

○

\*○



**HERRAJE FIJO 180° VIDRIO-VIDRIO**  
FIXATION VERRE-VERRE 180°  
BRACKET GLASS-GLASS 180°  
MORSETTO VETRO-VETRO 180°  
**4097/032**

Cu	inox s.s.	90x45 mm	€/u
6-12 mm		2x ∅ 14 mm	

\*○



**HERRAJE FIJO 90° PARED-VIDRIO**  
FIXATION MUR-VERRE 90°  
BRACKET WALL-GLASS 90°  
MORSETTO PARETE-VERRO 90°  
**4108/022** inox  
**4108/Z32** zamak  
**4108/Z0N** zamak negro

		45x45 mm	€/u
8-12 mm		∅ 16 mm	

○

○

○



**MORSETO VIDRIO-PARED**  
FIXATION VERRE-MUR  
BRACKET GLASS-WALL  
MORSETTO VETRO-PARETE  
**4105/032**

Cu		60x50 mm	€/u
8-12 mm		∅ 16 mm	

○



**HERRAJE FIJO 90° VIDRIO-VIDRIO**  
FIXATION VERRE-VERRE 90°  
BRACKET GLASS-GLASS 90°  
MORSETTO VETRO-VETRO 90°  
**4099/022**

inox s.s.		90x45 mm	€/u
8-12 mm		3x ∅ 14 mm	

○

## "U" INOX



**"U" INOX PULIDO**  
U INOX POLI  
U POL. STAINLESS STEEL  
U INOX LUCIDO

15x15x15x1 mm  
**4375/122**  
15x12x15x1 mm  
**4376/122**  
25x15x25x1 mm  
**4377/122**

inox s.s.	L 3 m	€/m
-----------	-------	-----

max. 12 mm	○
------------	---

max. 8 mm	○
-----------	---

max. 12 mm	○
------------	---

○

# COTEK

HERRAJES ARQUITECTURA - ACCESSOIRES ARCHITECTURE  
ARCHITECTURE HARDWARE - ACCESSORI ARCHITETTURA

## HERRAJES FIJOS - BARANDILLAS



**ANCLAJE VIDRIO-PARED**  
SUPPORT MUR-VERRE  
BRACKET WALL-GLASS  
UNIONE PARETE-VERRO  
**\*4370/028**

inox s.s.	10-12 mm	€/u
	∅ 26 mm	∇ ∅ 32 mm

\*○



**ANCLAJE PARED**  
SUPPORT MUR  
BRACKET WALL  
UNIONE PARETE  
**\*4384/028**

inox s.s.	∅ 4386-4387	€/u
-----------	-------------	-----

\*○



**ANCLAJE VIDRIO**  
SUPPORT VERRE  
BRACKET GLASS  
UNIONE VETRO  
**\*4383/028**

inox s.s.		€/u
	∅ 26 mm	∇ ∅ 32 mm
	∅ 4386-4387	

\*○



**ANCLAJE DOBLE VIDRIO**  
SUPPORT DOUBLES VERRE  
DOUBLE BRACKET GLASS  
UNIONE VETRO DOPPIA  
**\*4385/028**

inox s.s.	10-12 mm	€/u
	∅ 12 mm	∅ 4386-4387

\*○



**BARRA CONEXIÓN**  
BIELLE  
CONNECTING ROD  
BARRA DI UNIONE

**\*4386/028 60 mm**  
**\*4387/028 103 mm**

inox s.s.	∅ 4385-4384-4383	€/u
-----------	------------------	-----

\*○

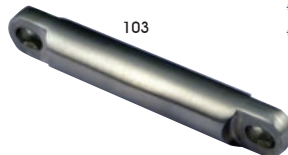

## KITS HERRAJES PARA MAMPARAS/BARANDILLAS

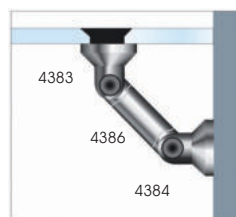

**ANCLAJE VIDRIO-PARED 2 ARTICULACIONES**  
SUPPORT MUR-VERRE 2 ARTICOLATIONES  
BRACKET WALL-GLASS 2 ARTICOLATIONS  
UNIONE PARETE-VERRO 2 ARTICOLAZIONI  
4383 1 u.  
4384 1 u.  
4386 1 u.  
**\*4364/028**

inox s.s.		€/u
-----------	--	-----

\*○

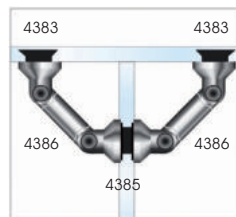

**ANCLAJE DOBLE VIDRIO-VIDRIO ARTICULADO**  
SUPPORT DOUBLES VERRE-VERRE ARTICULÉ  
DOUBLE BRACKET GLASS-GLASS ARTICULATED  
DOPPIA UNIONE VETRO-VETRO ARTICOLATO  
4383 2 u.  
4385 1 u.  
4386 2 u.  
**\*4367/028**

inox s.s.		€/u
-----------	--	-----

\*○

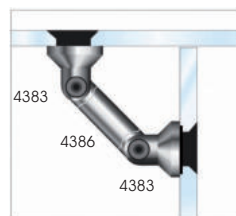

**ANCLAJE VIDRIO-VIDRIO 2 ARTICULACIONES**  
SUPPORT VERRE-VERRE 2 ARTICOLATIONES  
BRACKET GLASS-GLASS 2 ARTICOLATIONS  
UNIONE VETRO-VETRO 2 ARTICOLAZIONI  
4383 2 u.  
4386 1 u.  
**\*4368/028**

inox s.s.		€/u
-----------	--	-----

\*○

# COTEK - CERRADURAS

HERRAJES PARA PUERTAS - QUINCAILLERIE DE PORTE  
DOORS PATCH FITTINGS - ACCESSORI PER PORTE

CR. BRILLO CHR. POLI BR. CHR CR. LUC.	PL. MATE ANOD. M AN. CAN. ALL. NATUR.	INOX BR INOX POLI P. S. S. INOX LUC	C. SAT. NK SAT. NK. C SAT. NK. C C. SAT. NK
32	01	22	38

## CERRADURAS SIN MUESCAS



**CERRADURA SIN MUESCA**  
SERRURE SANS ENCOCHE  
LOCK WITHOUT CUT-OUT  
SERRATURA SENZA TACCA  
CUBILETE 1801 INCLUIDO  
GÄUCHE 1801 INCLUS  
STRIKE 1801 INCLUDED  
CONTROSERRATURA 1801 INCLUSA

1800/0..10mm  
1799/0..12mm

inox s.s.		70x63	€/u
	10-12 mm	∅1802	

○ ○  
○ ○



**CONTRACERRADURA VIDRIO SIN MUESCA**  
GÄUCHE VERRE SANS ENCOCHE  
GLASS STRIKE WITHOUT CUT-OUT  
CONTROSERRATURA VETRO SENZA TACCA

1802/0..10mm  
1803/0..12mm

inox s.s.		70x63	€/u
	10-12 mm	∅1800-1799	

○ ○  
○ ○



**CERRADURA VIDRIO-PARED SIN MUESCA**  
SERRURE VERRE-MUR SANS ENCOCHE  
GLASS-WALL LOCK WITHOUT CUT-OUT  
SERRATURA VETRO-PARETE SENZA TACCA

4193/P22

inox s.s.		90x64	€/u
	10-12 mm		

○



**CERRADURA VIDRIO-VIDRIO SIN MUESCA**  
SERRURE VERRE-VERRE SANS ENCOCHE  
GLASS-GLASS LOCK WITHOUT CUT-OUT  
SERRATURA VETRO-VETRO SENZA TACCA

4193/V22

inox s.s.		180x64	€/u
	10-12 mm		

○

## PESTILLO SIN MUESCA



**PESTILLO SIN MUESCA**  
VERROU SANS ENCOCHE  
BOLT WITHOUT CUT-OUT  
CHIAVISTELLO SENZA TACCA

4175/032 Latón

CR. BRILLO CHR. POLI BR. CHR CR. LUC.	32		
Cu		60x50	€/u
	8-10 mm	∅4177	

○



**CERRADURA SIN MUESCA CON LLAVE**  
SERRURE SANS ENCOCHE AVEC CLÉ  
LOCK WITHOUT CUT-OUT WITH KEY  
SERRATURA SENZA TACCA CON CHIAVE

4176/032 Zamak

Zn		60x50	€/u
	8-10 mm	∅4177	

○



**CUBILETE**  
GÄUCHE  
STRIKE PLATE  
CONTROSERRATURA

4177/032

Cu		∅ 12	∅ 25 (10)	€/u
		∅4175-4176		

○



**CONTRA PESTILLO VIDRIO SIN MUESCA**  
GÄUCHE VERRE SANS ENCOCHE  
GLASS STRIKE PLATE WITHOUT CUT-OUT  
CONTROSERRATURA VETRO SENZA TACCA

4158/032

Cu		30x45	€/u
	8-12 mm	∅ 4159	

○



**PESTILLO SIN MUESCA**  
VERROU SANS ENCOCHE  
BOLT WITHOUT CUT-OUT  
CHIAVISTELLO SENZA TACCA

4159/032

Cu		30x45	€/u
	8-12 mm	∅ 4177-4158	

○



**CUBILETE**  
GÄUCHE  
STRIKE PLATE  
CONTROSERRATURA

4177/032

Cu		∅ 12	∅ 25 (10)	€/u
		∅4159		

○

## CERRADURAS PARA CORREDERAS



BOMBÍN EUROPEO

**CERRADURA PUERTA**  
CORREDERA VIDRIO-PARED  
SERRURE PORTES COULISSANTS  
VERRE-MUR  
SLIDING DOORS LOCK  
GLASS-WALL  
SERRRATURE PORTE  
SCORREVOU VETRO-PARETE

**LLAVE-PESTILLO**  
serrure-verrou  
key bolt  
chiave-pomolo

**SIMÉTRICA**  
SYMMÉTRIQUE  
SYMMETRIC  
SIMMETRICA

4224/0..

Al		8-12 mm	€/u
----	--	---------	-----

○ ○



**CERRADURA PUERTA**  
CORREDERA VIDRIO-VIDRIO  
SERRURE PORTES COULISSANTS  
VERRE-VERRE  
SLIDING DOORS LOCK  
GLASS-GLASS  
SERRRATURE PORTE  
SCORREVOU VETRO-VETRO

**LLAVE-PESTILLO**  
serrure-verrou  
key bolt  
chiave-pomolo

**SIMÉTRICA**  
SYMMÉTRIQUE  
SYMMETRIC  
SIMMETRICA

4225/0..

Al		8-12 mm	€/u
----	--	---------	-----

○ ○



**BOMBIN LLAVE**  
AMBOS LADOS  
4224/012

○

## CERRADURA MONTSE

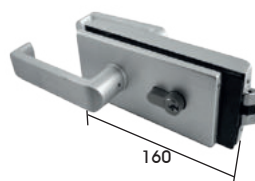

**CERRADURA CON MANETA**  
SERRURE AVEC POIGNÉE  
DOOR LOCK WITH HANDLE  
SERRATURA CON MANIGLIA

5577/001  
5577/00N

Al		8-10 mm	€/u
----	--	---------	-----

○ ○



**CONTRACERRADURA VIDRIO**  
CONTRE-VERROU VERRE  
GLASS COUNTERLOCK  
CONTROSERRATURA VETRO

5578/001  
5578/00N

○ ○



**NUEVO**



# COTEK - CERRADURAS

CERRADURAS PUERTAS - SERRURES PORTES  
DOORS LOCKS - SERRATURE PORTE

NEGRO NOIR BLACK NERO	INOX SAT INOX SAT S.S.S. INOX SAT	INOX BR INOX POL P.S.S. INOX LUC
0N	28	22

## MONICA



CON LLAVE.  
AVEC CLÉ, WITH KEY, CON CHIAVE

CERRADURA CON MANETA  
Y CONTRACERRADURA  
SERRURE AVEC POIGNÉE  
ET GAÛCHE  
DOOR LOCK WITH HANDLE  
AND STRIKE PLATE  
SERRATURA CON MANIGLIA  
E CONTOSERRATURA

inox s.s.	Zn	Fe	8-10mm	€/u
--------------	----	----	--------	-----

4173/0..

**NUEVO**

4173/00N



BOMBÍN CON PESTILLO  
4173/012



CERRADURA CON MANETA  
Y CONTRACERRADURA  
SERRURE AVEC POIGNÉE  
DOOR LOCK WITH HANDLE  
ET GAÛCHE  
SERRATURA CON MANIGLIA  
AND STRIKE PLATE  
E CONTOSERRATURA

inox s.s.	Zn	Fe	8-10mm	€/u
--------------	----	----	--------	-----

4179/0..

4179/031

CON LLAVE.  
AVEC CLÉ, WITH KEY, CON CHIAVE  
PORTA BATTENTE.  
PORTE BATTANTE, SWINGING DOOR, PORTA BATTENTE

**NUEVO**

4179/00N



CERRADURA CON MANETA  
Y CONTRACERRADURA  
SERRURE AVEC POIGNÉE ET GAÛCHE  
DOOR LOCK WITH HANDLE AND STRIKE PLATE  
SERRATURA CON MANIGLIA E CONTOSERRATURA

inox s.s.	Zn	Fe	8-10mm	€/u
--------------	----	----	--------	-----

4145/0..



SIN LLAVE  
SANSCLÉ, WITHOUT KEY, SENZA CHIAVE

CONTRACERRADURA  
VIDRIO  
GAÛCHE VERRE  
GLASS STRIKE PLATE  
CONTOSERRATURA VETRO

inox s.s.	Fe	8-10mm	€/u
--------------	----	--------	-----

4174/0..

**NUEVO**

4173/00N



CONTRACERRADURA  
PARED Ó 4174 BATTENTE  
GAÛCHE BATTANT MUR OU 4174  
WALL OR 4174 WING STRIKE PLATE  
CONTOSERRATURA BATTENTE  
PARETE Ó 4174

inox s.s.	∞ 4174	€/u
--------------	--------	-----

4157/012

## SONIA



CERRADURA CON MANETA  
Y CONTRACERRADURA PARED  
SERRURE AVEC POIGNÉE  
ET GAÛCHE MUR  
DOOR LOCK WITH HANDLE  
AND STRIKE PLATE  
SERRATURA CON MANIGLIA  
E CONTOSERRATURA MURO

Al	8-10mm	€/u
----	--------	-----

5569/022



CONTRACERRADURA VIDRIO  
GAÛCHE VERRE  
GLASS STRIKE  
CONTOSERRATURA VETRO

Al	8-10mm	€/u
----	--------	-----

5570/022

# COTEK - CERRADURAS

HERRAJES PARA PUERTAS - QUINCAILLERIE DE PORTE  
DOORS PATCH FITTINGS - ACCESSORI PER PORTE

CR.BRILLO CH.R.POL BR.CH CR.LUC.	PL.MATE ANOD.M AN.CAN. ALL.NATUR.	INOX BR INOX POL P.S.S. INOX LUC	INOX SAT INOX SAT S.S.S. INOX SAT
32	01	22	28

## MARTA



CERRADURA CON MANETA  
Y CONTRACERRADURA PARED  
SERRURE AVEC POIGNÉE  
ET GAÛCHE MUR  
DOOR LOCK WITH HANDLE  
AND STRIKE PLATE  
SERRATURA CON MANIGLIA  
E CONTOSERRATURA MURO

inox s.s.	8-10mm	€/u
--------------	--------	-----

4228/022



BOMBÍN CON PESTILLO

4228/022



CERRADURA CON MANETA  
Y CONTRACERRADURA VIDRIO  
SERRURE AVEC POIGNÉE  
ET GAÛCHE VERRE  
DOOR LOCK WITH HANDLE  
AND GLASS STRIKE  
SERRATURA CON MANIGLIA  
E CONTOSERRATURA VETRO

inox s.s.	8-10mm	€/u
--------------	--------	-----

4229/022



CONTRACERRADURA  
PARED/BATTENTE  
GAÛCHE BATTANT MUR  
WALL WING STRIKE PLATE  
CONTOSERRATURA BATTENTE  
PARETE  
4257/022 izq.  
4258/022 der.

inox s.s.	∞ 4256	€/u
--------------	--------	-----

CONTRACERRADURA VIDRIO  
GAÛCHE VERRE  
GLASS STRIKE  
CONTOSERRATURA VETRO  
4256/022 der.

inox s.s.	∞ 4257-4258	€/u
--------------	-------------	-----



KIT PUERTA BATTENTE  
KIT PORTE BATTANTE  
KIT SWINGING DOOR  
KIT PORTA BATTENTE

1478/032 2 u.  
4228/022 1 u.  
4249/032

CR.BRILLO  
CH.R.POL  
BR.CH  
CR.LUC.

32

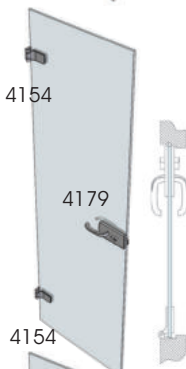

KIT PUERTA BATTENTE  
KIT PORTE BATTANTE  
KIT SWINGING DOOR  
KIT PORTA BATTENTE

4154 2 u.  
4179 1 u.  
4399/032  
4399/031  
4399/00N

CR.BRILLO  
CH.R.POL  
BR.CH  
CR.LUC.

32



KIT PUERTA BATTENTE  
KIT PORTE BATTANTE  
KIT SWINGING DOOR  
KIT PORTA BATTENTE

4194 2 u.  
5577 1 u.  
4289/001  
4289/00N

CR.BRILLO  
CH.R.POL  
BR.CH  
CR.LUC.

32



# COTEK

CERRADURAS PUERTAS - SERRURES PORTES  
DOORS LOCKS - SERRATURE PORTE

## TIRADORES - MANILLAS

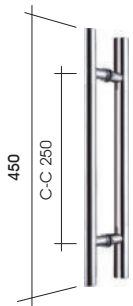

**MANILLA DOBLE 45 CM**  
POIGNÉE DOUBLE 45 CM  
DOUBLE DOOR HANDLE 45 CM  
MANIGLIA DOPPIA 45 CM  
1590/0..

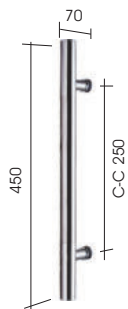

**MANILLA SENCILLA 45 CM**  
POIGNÉE 45 CM  
SINGLE HANDLE 45 CM  
MANIGLIONE SEMPLICE 45 CM  
1594/022

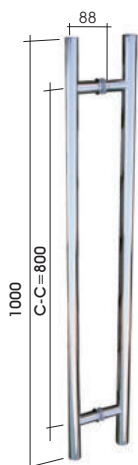

**MANILLA DOBLE 100 CM**  
POIGNÉE DOUBLE 100 CM  
DOUBLE DOOR HANDLE 100 CM  
MANIGLIA DOPPIA 100 CM  
1592/0..

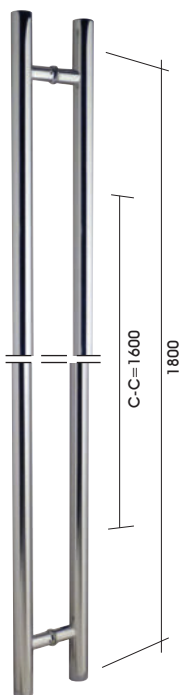

**MANILLA DOBLE 180 CM**  
POIGNÉE DOUBLE 180 CM  
DOUBLE DOOR HANDLE 180 CM  
MANIGLIA DOPPIA 180 CM  
1591/028

INOX BR	INOX SAT	NEGRO
INOX POLI	INOX SAT	NOIR
P.S.S.	S.S.S.	BLACK
INOX ILLC	INOX SAT	NERO
22	28	0N

inox s.s.	8-12 mm	Ø 25	€/u
	2xØ12 mm CC=250 mm		

○ ○ ○

inox s.s.	8-12 mm	Ø 25	€/u
	2xØ12 mm CC=250 mm		

○

inox s.s.	8-12 mm	Ø 25	€/u
	2xØ12 mm CC=800 mm		

○ ○

inox s.s.	8-12 mm	Ø 38	€/u
	2xØ12 mm CC=1600 mm		

○ ○

# COTEK

CERRADURAS PUERTAS - SERRURES PORTES  
DOORS LOCKS - SERRATURE PORTE

## TIRADOR CON CERRADURA

INOX BR	INOX SAT
INOX POLI	INOX SAT
P.S.S.	S.S.S.
INOX ILLC	INOX SAT
22	28

inox s.s.	10-12 mm	Ø 35	€/u
	1 x Ø mm 1 x Ø mm		

**MANILLA DOBLE 150 CM**  
+ CERRADURA Y PESTILLO  
POIGNÉE DOUBLE 150 CM  
+ SERRURE AND VERROU  
DOUBLE HANDLE 150 CM  
+ LOCK AND BOLT  
MANIGLIONE DOPPIO 150 CM  
+ SERRATURA E CHIAVISTELLO  
1598/0..

○ ○

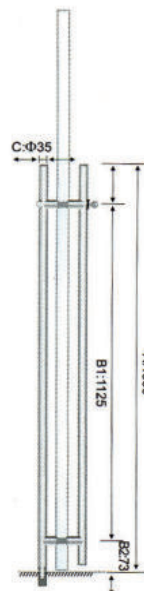

## TIRADOR PUERTAS TUBO 20X20

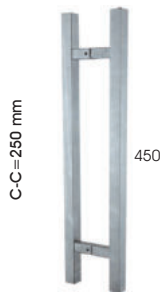

inox s.s.	8-12 mm	20x20	€/u
	2xØ12 mm CC=250 mm		

**MANILLA DOBLE 45 CM**  
POIGNÉE DOUBLE 45 CM  
DOUBLE DOOR HANDLE 45 CM  
MANIGLIA DOPPIA 45 CM  
1597/0..

○ ○

## TIRADOR PUERTAS TUBO 50X25



inox s.s.	8-12 mm	50x25	€/u
	2xØ12 mm CC=450 mm		

**MANILLA DOBLE 47,5 CM**  
POIGNÉE DOUBLE 47,5 CM  
DOUBLE DOOR HANDLE 47,5 CM  
MANIGLIA DOPPIA 47,5 CM  
1596/028

○

## TIRADOR PUERTAS TUBO Ø25



inox s.s.	6-12 mm	Ø25	€/u
	2xØ10 mm CC=250 mm		

**MANILLA DOBLE**  
POIGNÉE DOUBLE  
DOUBLE DOOR PULL  
MANIGLIA DOPPIA  
4126/022

○

**COTEK**

CERRADURAS PUERTAS - SERRURES PORTES  
DOORS LOCKS - SERRATURE PORTE

**TIRADORES Y MANILLAS**



d. 48

**TIRADOR DOBLE**  
BOUTON DOUBLE  
DOUBLE KNOB  
POMOLO DOPPIO  
\*1584/032



d. 35

**TIRADOR DOBLE**  
BOUTON DOUBLE  
DOUBLE KNOB  
POMOLO DOPPIO  
\*4119/0..

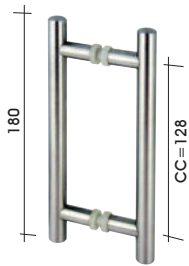

**MANILLA DOBLE**  
POIGNEÉ DOUBLE  
DOUBLE DOOR PULL  
MANIGLIA DOPPIA  
4127/0..

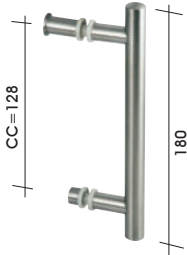

**MANILLA + POMO**  
POIGNEÉ + BOUTON  
DOOR PULL + KNOB  
MANIGLIA + POMOLO  
\*4128/0..



**MANILLA DOBLE**  
POIGNEÉ DOUBLE  
DOUBLE DOOR PULL  
MANIGLIA DOPPIA  
4139/Z32  
4139/Z0N negro

**MANILLA ALUMINIO**



**MANILLA DOBLE**  
POIGNEÉ DOUBLE  
DOUBLE DOOR PULL  
MANIGLIA DOPPIA  
4129/A32  
4129/A0N negro

CR. BRILLO CHR. POLI BR. CHR. CR. LUC.	CR. MATE CHR. M M. CHR. CR. OPAC	TITANIO TITANE TITANIUM TITANIO	INOX BR INOX POLI P. S.S. INOX LUC	INOX SAT INOX SAT S. S.S. INOX SAT
32	31	06	22	28

Al	6-12 mm	Ø48x43	Ø 10 mm	€/u
----	---------	--------	---------	-----

Al	6-10 mm	Ø45x28	Ø 12 mm	€/u
----	---------	--------	---------	-----

inox s.s.	6-10 mm	Ø14		€/u
		2 x Ø 10 mm	CC=128 mm	

inox s.s.	6-10 mm	Ø14		€/u
		2 x Ø 10 mm	CC=128 mm	

Zn	6-10 mm	226x34		€/u
		2 x Ø 6 mm	CC=192 mm	

Al	6-10 mm	259x13		€/u
		2 x Ø 6 mm	CC=220 mm	

**COTEK**

CERRADURAS PUERTAS - SERRURES PORTES  
DOORS LOCKS - SERRATURE PORTE

**UÑERO ALUMINIO ADHESIVO 3M**



**UÑERO DOBLE ADHESIVO**  
POIGNEÉ DOUBLE ADHESIVE  
DOUBLE ADHESIVE PULL  
POMO DOPPIO ADHESIVO  
4207/0..

**UÑERO INOX 304 ADHESIVO 3M**



**UÑERO DOBLE ADHESIVO**  
POIGNEÉ DOUBLE ADHESIVE  
DOUBLE ADHESIVE PULL  
POMO DOPPIO ADHESIVO  
4207/0..



**GALGA MONTAJE UÑEROS**  
GABARIT DE MONTAGE  
INSTALLATION TOOL  
SAGOMA AIUTO MONTAGGIO  
4209/000

**UÑERO ALUMINIO SIN MUESCA**



**POMO**  
POIGNEÉ  
KNOB  
POMO  
4223/0..

**UÑERO INOX 304 CON TALADRO**



**UÑERO**  
POIGNEÉ  
KNOB  
POMO  
4322/028



**UÑERO**  
POIGNEÉ  
KNOB  
POMO  
4337/028

PLÁSTICO PLASTIQUE PLASTIC PLASTICA	P. MATE ANOD. M AN. CHR. AN. OPAC	CR. BRILLO CHR. POLI BR. CHR. CR. LUC.	INOX BR INOX POLI P. S.S. INOX LUC	INOX SAT INOX SAT S. S.S. INOX SAT
09	01	32	22	28

inox s.s.	Ø 60		€/u
-----------	------	--	-----

Al	Ø 60		€/u
----	------	--	-----

Al			€/u
----	--	--	-----

Al	100	8-10 mm	€/u
----	-----	---------	-----

inox s.s.	8-12 mm	€/u
	Ø 50 mm	

inox s.s.	8-12 mm	€/u
	Ø 46 mm	

inox s.s.	8-12 mm	€/u
	Ø 46 mm	

**! NUEVO**



## COTEK - ÍNDEX

### BARANDILLAS Y MARQUESINAS

#### 1- PREMIUM 133

Selección de herraje de alta gama

##### A. SOPORTE SUELO CON ILUMINACIÓN SIN TALADROS

Soportes con sistema de regulación patentado y sistema de iluminación LED integrado en la base.

Vidrio 12-17,5 mm, Inox DUPLEX 2205

##### B. DISTANCIADOR INOX DUPLEX CON REGULACIÓN

Distanciador con sistema de regulación. Vidrio 10-22 mm,

Inox DUPLEX 2205

##### C. SOPORTES DE BARANDILLA INOX DUPLEX

Soportes con sistema de regulación TILT-LOCK

#### 2- SOPORTES SUELO 137

#### 3- REFUERZO BARANDILLAS 138

#### 4- PINZAS 139

#### 5- BOTONES 140

#### 6- PASAMANOS BARANDILLAS 141

#### 7- MARQUESINAS 142

**SERIE PREMIUM**

**SOPORTE CON LUZ LED**  
SOPORTE DE BARANDILLAS INOX DUPLEX CON LUZ LED RGB

5975/022 €/u

22

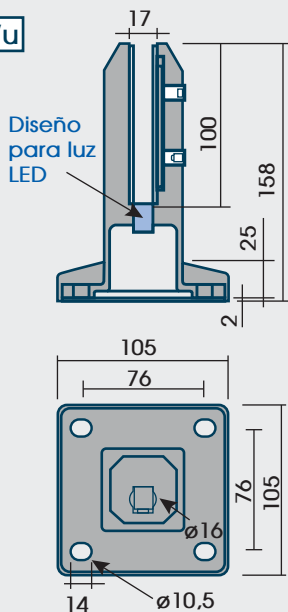

**IX** Inox 2205 DUPLEX

150 kg/u

10-14,28 mm



SIN AGUJEROS EN EL VIDRIO



- AJUSTE DE ALTURA Y AJUSTE DE INCLINACIÓN
- DISEÑADO PARA INSERTAR DIRECTAMENTE EL LED

- Diseñado para encajar directamente el LED en el herraje.
- Ajustable: en velocidad, brillo de la luz y el color RGB (16 colores).
- Vida: 20.000 horas
- Grado de impermeabilidad: IP67
- Tamaño de la luz: 16,5\*26mm

Transformador (de 240v a 12v)

24m de cable con empalmes "T" (Distancia entre "T" - 1,5m)

Control remoto de color RGB (Se recomienda instalar el lado elevado del inductor hacia arriba y no bloquear la señal de inducción con objetos extraños.)



16 cables de luz RGB (cables de 100 mm)



16 cables de extensión (250/455mm opcional)

Mando a distancia



5976/000

00

€/u

**Serie PREMIUM**

**SERIE PREMIUM**

# SOPORTE CON LUZ LED

SOPORTE DE BARANDILLAS INOX DUPLEX CON LUZ LED RGB

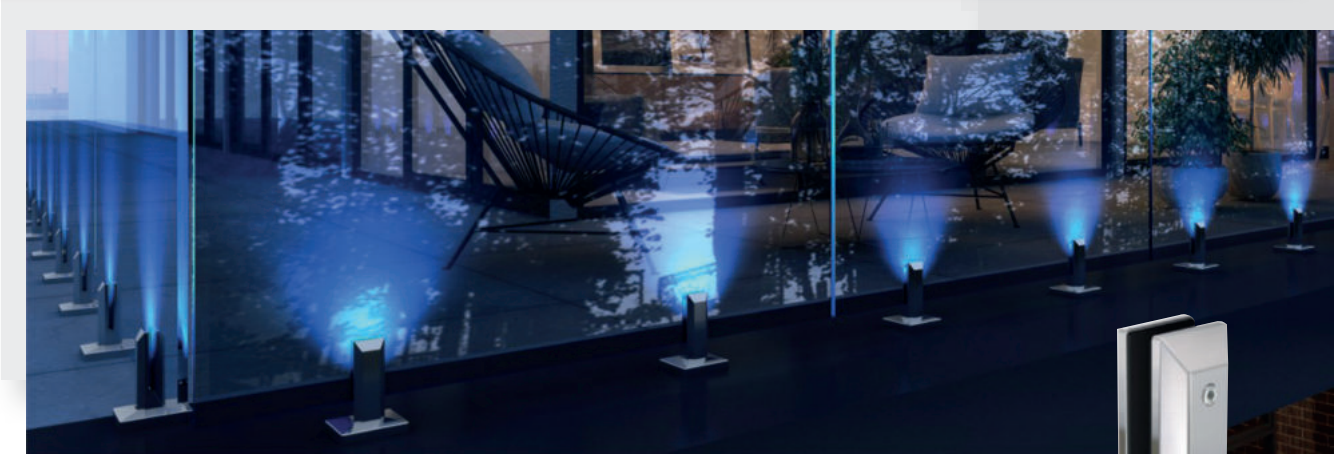

**MONTAJE**

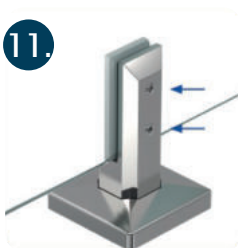
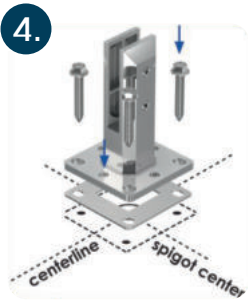
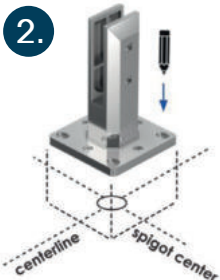
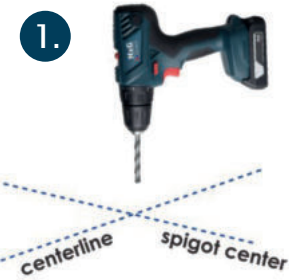

**Serie PREMIUM**

**SERIE PREMIUM**

# DISTANCIADOR INOX DUPLEX DE REGULACIÓN FRONTAL

SOPORTE DE BARANDILLAS INOX DUPLEX CON LUZ LED RGB

**Anclaje pared-vidrio**

- Ancre mur-verre
- Wall-glass anchor
- Ancoraggio muro-vetro

**5948/022**

**Llave de regulación 5948**

- Clé de régulation
- Regulation key
- Chiave di regolazione

**5948/012**

22



€/u



**ix** Inox 2205 DUPLEX

10-22 mm

Ø 38 mm

Ø24mm

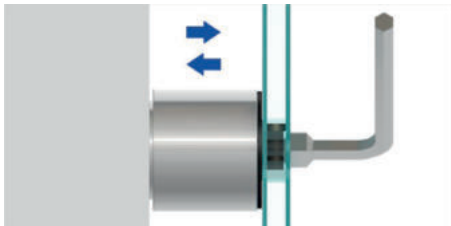

**INSTRUCCIONES DE MONTAJE 5948**

- 1.- Atornillar el elemento **A** a la pared con la tornillería mas adecuada según el tipo de pared.
- 2.- Enroscar la pieza **B** en la pieza **A** hasta el fondo.
- 3.- Enroscar el elemento **C** en el elemento **A**.
- 4.- Colocar el elemento **D** y colocar el cristal. Ajustar la posición de la fijación del elemento **A** (por la apertura que queda se puede acceder al tornillo de fijación de pared); Una vez ajustados los elementos **A** y **C** según necesidades, fijar con la llave **G2** el elemento **B** (desenroscar hasta que haga tope con el elemento **B**).
- 5.- Fijar con la llave **G1** el elemento **C**.
- 6.- Colocar el elemento **E**.
- 7.- Colocar el elemento **F** y fijar con la llave correspondiente.

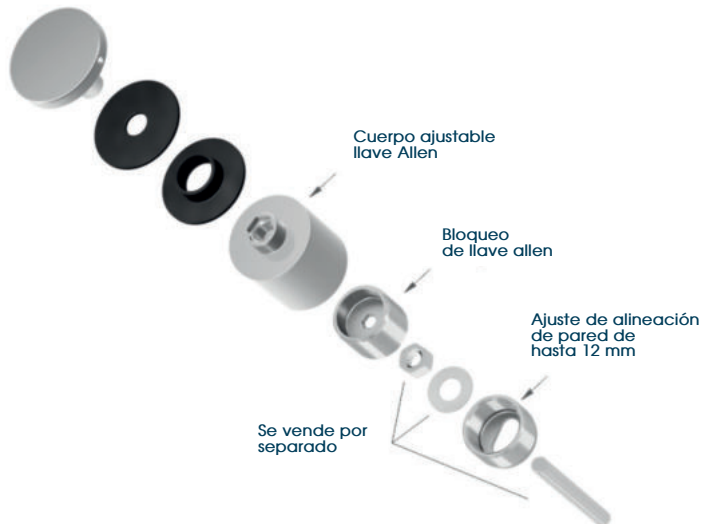
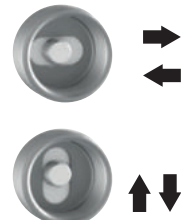
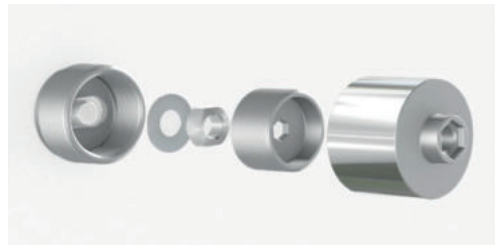

**Serie PREMIUM**



**SERIE PREMIUM**

# SOPORTES BARANDILLA DUPLEX

SOPORTES INOX 2205 DUPLEX CON TILT-LOCK

€/u

**5942/0..**

22 28 ON

○ ○ ○

**Anclaje pared-vidrio**

- Ancre mur-verre
- Wall-glass anchor
- Ancoraggio muro-vetro

---

**ix** Inox 2205 DUPLEX

12-17,5 mm

**SIN TALADROS EN EL VIDRIO**

CON TILT-LOCK

€/u

**5941/0..**

22 28

○ ○

**Anclaje pared-vidrio**

- Ancre mur-verre
- Wall-glass anchor
- Ancoraggio muro-vetro

---

**ix** Inox 2205 DUPLEX

12-17,5 mm

**SIN TALADROS EN EL VIDRIO**

CON TILT-LOCK

€/u

**1437/022**

22

○

**Anclaje pared-vidrio**

- Ancre mur-verre
- Wall-glass anchor
- Ancoraggio muro-vetro

---

**ix** Inox 2205 DUPLEX

12-17,5 mm

**SIN TALADROS EN EL VIDRIO**

CON TILT-LOCK

← VIDRIO INCLINADO HACIA ATRÁS

VIDRIO INCLINADO HACIA ADELANTE →

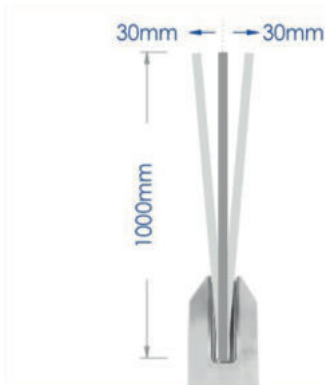

## TILT-LOCK

Significa "inclinarse y bloquear" un proceso simple que le permite simplemente inclinar el vidrio en los soportes para la alineación correcta y bloquear los tornillos sin cabeza.

**Serie PREMIUM**



# COTEK

BARANDILLAS DE VIDRIO - GARDE-CORPS DE VERRE  
GLASS BALUSTRADES - BALAUSTRÉ DI VETRO

INOX BR  
INOX POLI  
P.S.S.  
INOX LUC  
22



SOPORTE BARANDILLA  
SUPPORT GARDE-CORPS  
SUPPORT BALUSTRADE  
SUPPORTO BALAUSTRÀ  
INOX duplex 2205  
5970/022 12-21.5 mm

inox (s.s.) 12-21.5mm €/u  
SIN TALADROS EN EL VIDRIO



SOPORTE BARANDILLA  
SUPPORT GARDE-CORPS  
SUPPORT BALUSTRADE  
SUPPORTO BALAUSTRÀ  
INOX duplex 2205  
5973/022 12-21.5 mm

inox (s.s.) 12-21.5mm €/u  
SIN TALADROS EN EL VIDRIO

# COTEK

BARANDILLAS DE VIDRIO - GARDE-CORPS DE VERRE  
GLASS BALUSTRADES - BALAUSTRÉ DI VETRO

INOX BR  
INOX POLI  
P.S.S.  
INOX LUC  
22



SOPORTE BARANDILLA  
SUPPORT GARDE-CORPS  
SUPPORT BALUSTRADE  
SUPPORTO BALAUSTRÀ  
INOX duplex 2205  
5972/022 12-21.5 mm

inox (s.s.) 12-21.5mm €/u  
SIN TALADROS EN EL VIDRIO



SOPORTE BARANDILLA  
SUPPORT GARDE-CORPS  
SUPPORT BALUSTRADE  
SUPPORTO BALAUSTRÀ  
INOX duplex 2205  
5971/022 12-21.5 mm

inox (s.s.) 12-21.5mm €/u  
SIN TALADROS EN EL VIDRIO

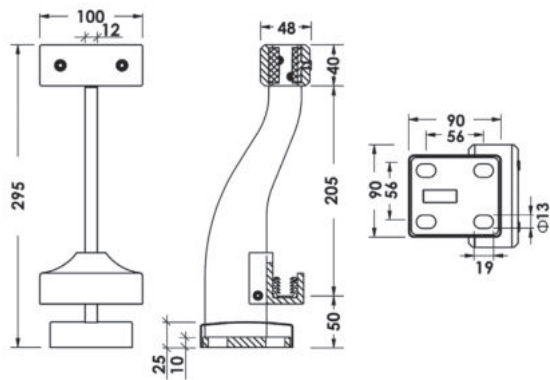
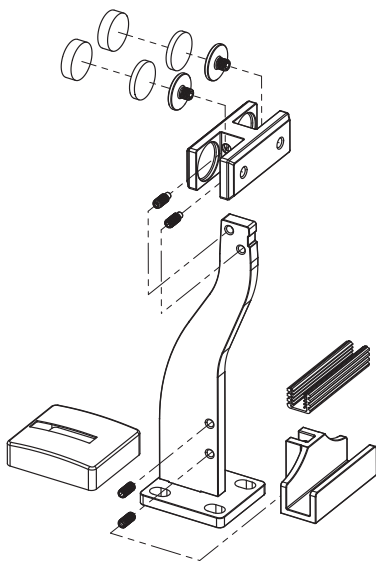

**COTEK**

BARANDILLAS DE VIDRIO - GARDE-CORPS DE VERRE  
GLASS BALUSTRADES - BALAUSTRÉ DI VETRO

NEGRO	INOX BR	INOX SAT
NOIR	INOX POLI	INOX SAT
BLACK	P.S.S.	S.S.S.
NERO	INOX LUC	INOX SAT
<b>0N</b>	<b>22</b>	<b>28</b>

**SOPORTES BARANDILLAS SUELO**

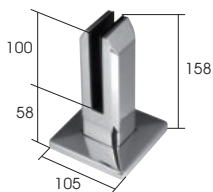

SOPORTE BARANDILLA  
SUPPORT GARDE-CORPS  
SUPPORT BALUSTRADE  
SUPPORTO BALAUSTRÀ

inox s.s.	12 mm	€/u
SIN TALADROS EN EL VIDRIO		

**1434/022** 12 mm

**INOX duplex 2205**

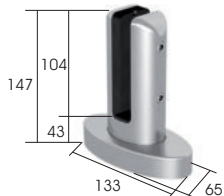

SOPORTE BARANDILLA  
SUPPORT GARDE-CORPS  
SUPPORT BALUSTRADE  
SUPPORTO BALAUSTRÀ

inox s.s.	10-22 mm	€/u
SIN TALADROS EN EL VIDRIO		

**1436/022** 10-22 mm

**INOX duplex 2205**

CR. BRILLO	PL. MATE	INOX BR	NEGRO
CR. POLI	ANOD. M	INOX POLI	NOIR
BR. CR.	AN. CHR	P.S.S.	BLACK
CR. LUC.	AN. OPAC	INOX LUC	NERO
<b>32</b>	<b>01</b>	<b>22</b>	<b>0N</b>

**REFUERZO BARANDILLAS**



SOPORTE BARANDILLA  
SUPPORT GARDE-CORPS  
SUPPORT BALUSTRADE  
SUPPORTO BALAUSTRÀ

inox s.s.	16,7-19mm	€/u
SIN TALADROS EN EL VIDRIO		

**INOX duplex 2205**  
**5944/022** 16,7-19 mm



SOPORTE BARANDILLA  
SUPPORT GARDE-CORPS  
SUPPORT BALUSTRADE  
SUPPORTO BALAUSTRÀ

inox s.s.	16,7-19mm	€/u
SIN TALADROS EN EL VIDRIO		

**INOX duplex 2205**  
**5945/022** 16,7-19 mm



SOPORTE BARANDILLA  
SUPPORT GARDE-CORPS  
SUPPORT BALUSTRADE  
SUPPORTO BALAUSTRÀ

inox s.s.	16,7-19mm	€/u
SIN TALADROS EN EL VIDRIO		

**INOX duplex 2205**  
**5946/022** 16,7-19 mm



SOPORTE BARANDILLA  
SUPPORT GARDE-CORPS  
SUPPORT BALUSTRADE  
SUPPORTO BALAUSTRÀ

inox s.s.	16,7-19mm	€/u
SIN TALADROS EN EL VIDRIO		

**INOX duplex 2205**  
**5947/022** 16,7-19 mm

**! NUEVO**

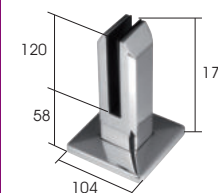

SOPORTE DE BARANDILLA  
SUPPORT DE GARDE-CORPS  
RAILING BRACKET  
STAFFA PER RINGHIERA

inox s.s.	12-16 mm	€/u
SIN TALADROS EN EL VIDRIO		

**1435/022**

**INOX duplex 2205**

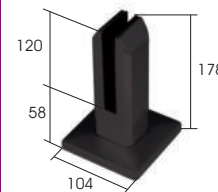

SOPORTE DE BARANDILLA  
SUPPORT DE GARDE-CORPS  
RAILING BRACKET  
STAFFA PER RINGHIERA

inox s.s.	12-16 mm	€/u
SIN TALADROS EN EL VIDRIO		

**1435/00N**

**INOX duplex 2205**

**UTILAJES PARA ALINEACIÓN VIDRIO HASTA 17,52mm**



UTILAJE ALINEACIÓN 180°  
SUPPORT GARDE-CORPS  
SUPPORT BALUSTRADE  
SUPPORTO BALAUSTRÀ

inox s.s.	16,7-19mm	€/u
SIN TALADROS EN EL VIDRIO		

**INOX duplex 2205**  
**5980/001** 16,7-19 mm



UTILAJE ALINEACIÓN 90°  
SUPPORT GARDE-CORPS  
SUPPORT BALUSTRADE  
SUPPORTO BALAUSTRÀ

inox s.s.	16,7-19mm	€/u
SIN TALADROS EN EL VIDRIO		

**INOX duplex 2205**  
**5981/001** 16,7-19 mm



UTILAJE ALINEACIÓN  
SUPPORT GARDE-CORPS  
SUPPORT BALUSTRADE  
SUPPORTO BALAUSTRÀ

inox s.s.	16,7-19mm	€/u
SIN TALADROS EN EL VIDRIO		

**INOX duplex 2205**  
**5982/000** 16,7-19 mm

**! NUEVO**



SOPORTE BARANDILLA  
SUPPORT GARDE-CORPS  
SUPPORT BALUSTRADE  
SUPPORTO BALAUSTRÀ

inox s.s.	12-21,5 mm	€/u
SIN TALADROS EN EL VIDRIO		

**INOX duplex 2205**  
**5943/022** 12-21,5 mm

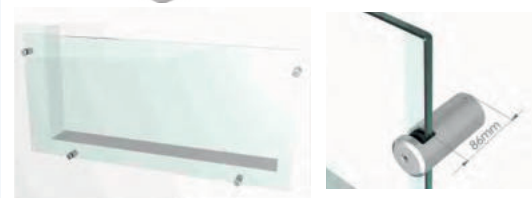

**! NUEVO**

**COTEK**

BARANDILLAS DE VIDRIO - GARDE-CORPS DE VERRE  
GLASS BALUSTRADES - BALAUSTRÉ DI VETRO

CR. BRILLO	PL. MATE	INOX BR	INOX SAT
CH. POLI	ANOD. M	INOX POLI	INOX SAT
BR. CHR	AN. CHR	P. S. S.	S. S. S.
CR. LUC.	AN. OPAC	INOX LUC	INOX SAT
<b>32</b>	<b>01</b>	<b>22</b>	<b>28</b>

**PINZAS BARANDILLAS INOX 316**



SOPORTE VIDRIO BASE PLANA  
PINCE VERRE BASE PLATE  
GLASS CLAMP FLAT BASE  
MORSETTO VETRO BASE PIANA  
ZAMAK

Zn	6-10mm	55x55	€/u
----	--------	-------	-----

**1415/032 6-10 mm**



SOPORTE VIDRIO BASE PLANA  
PINCE VERRE BASE PLATE  
GLASS CLAMP FLAT BASE  
MORSETTO VETRO BASE PIANA  
INOX 316

inox s.s.	6-8-10mm	40x50	€/u
-----------	----------	-------	-----

**1410/022 6-8-10 mm**



SOPORTE VIDRIO BASE PLANA  
PINCE VERRE BASE PLATE  
GLASS CLAMP FLAT BASE  
MORSETTO VETRO BASE PIANA  
INOX 316

inox s.s.	12mm	68x45	€/u
-----------	------	-------	-----

**1427/022 12 mm**



SOPORTE CRISTAL + SOPORTE  
ESQUINA Y PIN SEGURIDAD  
PINCE VERRE BASE PLATE +  
SUPPORT ANGLE + ÉPINGLE SÛRETÉ  
GLASS CLAMP FOR TUBE +  
CORNER SUPPORT + SAFETY PIN  
MORSETTO VETRO BASE PIANA +  
APPOGGIO ANGOLO + PIN SICUREZZA  
INOX 316

inox s.s.	10-12mm	55 x 55	€/u
-----------	---------	---------	-----

**1422/022**

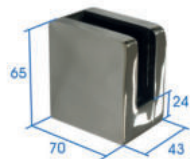

SOPORTE VIDRIO BASE PLANA  
PINCE VERRE BASE PLATE  
GLASS CLAMP FLAT BASE  
MORSETTO VETRO BASE PIANA  
INOX 316

inox s.s.	8+8/10+10	55x55	€/u
-----------	-----------	-------	-----

SIN TALADROS EN EL VIDRIO

**1429/022**

**! NUEVO**



SOPORTE VIDRIO BASE PLANA  
PINCE VERRE BASE PLATE  
GLASS CLAMP FLAT BASE  
MORSETTO VETRO BASE PIANA  
INOX duplex 2205

inox s.s.	10mm	55x55	€/u
-----------	------	-------	-----

**1424/022 10 mm**



GOMAS PARA VIDRIO DE 12 MM  
CAOUTCHOUC POUR VERRE 12 MM  
RUBBERS FOR 12 MM GLASS  
GOMME PER VETRO DI 12 MM

**1424/G12 12 mm**  
**1424/G10 10 mm**



SOPORTE INFERIOR VIDRIO  
BASE INF. VERRE  
GLASS BOTTOM SUPPORT  
SUPPORTO INFERIORE VETRO  
INOX duplex 2205

**1424/B22**

**COTEK**

BARANDILLAS DE VIDRIO - GARDE-CORPS DE VERRE  
GLASS BALUSTRADES - BALAUSTRÉ DI VETRO

CR. BRILLO	PL. MATE	INOX BR	INOX SAT
CH. POLI	ANOD. M	INOX POLI	INOX SAT
BR. CHR	AN. CHR	P. S. S.	S. S. S.
CR. LUC.	AN. OPAC	INOX LUC	INOX SAT
<b>32</b>	<b>01</b>	<b>22</b>	<b>28</b>

**PINZAS BARANDILLAS KRONOS**

inox s.s.	8 - 12,76	65x45	€/u
-----------	-----------	-------	-----



SOPORTE VIDRIO BASE PLANA Y REDONDA  
PINCE VERRE BASE PLATE  
GLASS CLAMP FLAT BASE  
MORSETTO VETRO BASE PIANA  
INOX 316

SE VENDE EN CAJAS DE 4 UNIDADES

**1409/028 Ø42,4 - Ø48,3mm**  
**1411/028 8 - 12,76 mm**

REGULACIÓN ESPESOR VIDRIO

**1409/028**      **1411/028**

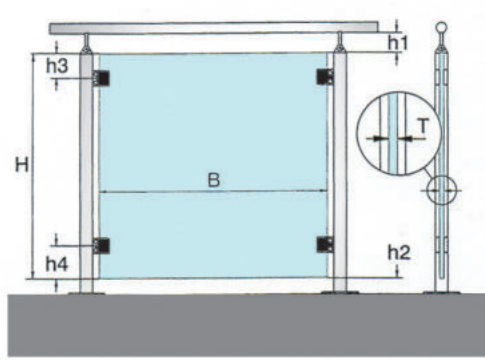

Dimensiones (mm)	min.	max.
B Anchura del vidrio	500	1000-1200 Recom.
T Espesor del vidrio	Ver modelo correspondiente	Ver modelo correspondiente
H Altura del vidrio	800	1000
h1 Distancia borde superior - barandilla	10	50 sin protección de borde 120 con protección de borde
h2 Distancia borde inferior - pavimento	10	50 sin protección de borde 120 con protección de borde
h3 Distancia borde superior - eje central de la pinza	100	150
h4 Distancia borde inferior - eje central de la pinza	100	150

## COTEK

BARANDILLAS DE VIDRIO - GARDE-CORPS DE VERRE  
GLASS BALUSTRADES - BALAUSTRÉ DI VETRO

NEGRO NOIR BLACK NERO	PL. MATE ANOD. M AN. CHR AN. OPAC	INOX BR INOX POL P. S.S. INOX LUC	INOX SAT INOX SAT S.S.S. INOX SAT
0N	01	22	28

### INOX DUPLEX 2205

ANCLAJE PARED-VIDRIO INOX DUPLEX 2205

ANCE MUR-VERRE  
WALL-GLASS ANCHOR  
ANCORAGGIO A PARETE IN VETRO  
4327/D22 INOX DUPLEX 2205  
4327/D28 INOX DUPLEX 2205



Ø 49mm



Ø 52mm

### INOX 304

ANCLAJE PARED-VIDRIO INOX 304

ANCE MUR-VERRE  
WALL-GLASS ANCHOR  
ANCORAGGIO A PARETE IN VETRO  
4314/022 INOX 304  
4314/028 INOX 304  
4314/00N INOX 304



inox s.s.	Ø 52 mm	Ø 20mm	€/u
	8-21,52 mm		

inox s.s.	Ø 52 mm	Ø 20mm	€/u
	8-21,52 mm		

## COTEK

BARANDILLAS DE VIDRIO - GARDE-CORPS DE VERRE  
GLASS BALUSTRADES - BALAUSTRÉ DI VETRO

INOX BR INOX POL P. S.S. INOX LUC	INOX SAT INOX SAT S.S.S. INOX SAT
22	28

### DISTANCIADOR INOX 304



ANCLAJE PARED-VIDRIO  
FIXATION MUR/VERRE  
WALL-GLASS SUPPORT POINT  
UNIONE PARETE-VETRO  
INOX duplex 2205  
5949/022

inox s.s.	Ø 38 mm	Ø 24mm	€/u
	10-22 mm		

ANCLAJE PARED-VIDRIO  
FIXATION MUR/VERRE  
WALL-GLASS SUPPORT POINT  
UNIONE PARETE-VETRO  
\*4324/022

inox s.s.	10-12mm	Ø 35	€/u
	Ø 26 mm	∇ Ø 32 mm	

ANCLAJE PARED-VIDRIO  
FIXATION MUR/VERRE  
WALL-GLASS SUPPORT POINT  
UNIONE PARETE-VETRO  
\*4346/022

inox s.s.	10-12mm	Ø 35	€/u
	Ø 26 mm	∇ Ø 32 mm	

ANCLAJE PARED-VIDRIO  
FIXATION MUR/VERRE  
WALL-GLASS SUPPORT POINT  
UNIONE PARETE-VETRO  
\*4346/P22

inox s.s.	10-12 mm	Ø 35 mm	€/u
	Ø 26 mm		

ANCLAJE PARED-VIDRIO  
VIDRIO 16-22 mm  
FIXATION MUR/VERRE 16-22 mm  
SUPPORT WALL-GLASS 16-22 mm  
UNIONE PARETE-VETRO 16-22 mm  
\*4347/022  
\*4347/028

inox s.s.	15-21,5mm	Ø 35	€/u
	Ø 26 mm	∇ Ø 32 mm	



LLAVE MONTAJE ANCLAJES  
OUTIL RÉGLABLE 19-51mm  
ADJUSTABLE TOOL 19-51mm  
UTENSILE REGOLABILE 19-51mm  
5969/012

inox s.s.	desde 19 hasta 51mm	€/u
-----------	---------------------	-----



**NUEVO**

Ø 30mm



Ø 35mm

### INOX 304

ANCLAJE PARED-VIDRIO INOX 304

ANCE MUR-VERRE  
WALL-GLASS ANCHOR  
ANCORAGGIO A PARETE IN VETRO  
4307/022 INOX 304  
4307/028 INOX 304  
4307/00N INOX 304

inox s.s.	Ø 35 mm	Ø 20mm	€/u
	8-21,52 mm		



**NUEVO**



### INOX 304

ANCLAJE BARANDILLA + ESCALERA VIDRIO  
ANCRAGE DE GARDE-CORPS + ESCALIER EN VERRE  
RAILING ANCHORAGE + GLASS STAIRCASE  
ANCORAGGIO RINGHIERA + SCALA IN VETRO  
5929/028 INOX 304 VIDRIO-VIDRIO  
5928/028 VIDRIO-PARED

inox s.s.	Ø 50 mm	Ø 16mm	€/u
	hasta 30 mm		



LLAVE REGULABLE x TORNILLO  
OUTIL RÉGLABLE x VIS  
ADJUSTABLE TOOL x SCREWS  
UTENSILE REGOLABILE x VITI  
4398/034

ZINCADO  
PL. ZINC  
ZINC PL.  
ZINCATO  
34



**NUEVO**



# COTEK

BARANDILLAS DE VIDRIO - GARDE-CORPS DE VERRE  
GLASS BALUSTRADES - BALAUSTRÉ DI VETRO

BRUTO BRUT RAW GREZZO	NEGRO NOIR BLACK NERO	INOX INOX P.S.S. INOX	BR POLI S.S.S. LUC	INOX INOX S.S.S. INOX	SAT SAT SAT SAT
00	0N	22	28		

## \*PERFIL PASAMANO

MÁXIMA GARANTÍA DE CALIDAD  
GARANTIE DE QUALITÉ MAXIMALE  
MAXIMUM QUALITY GUARANTEE  
MASSIMA GARANZIA DI QUALITÀ

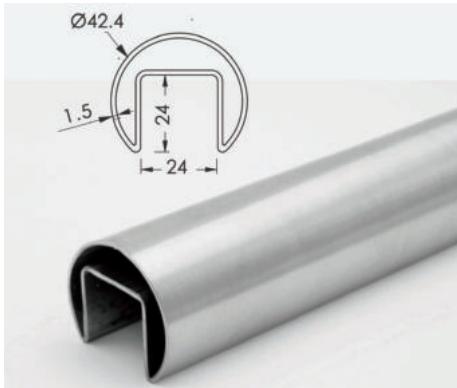

PROFILO PASAMANO Ø42,2 PROFIL GARDE-CORPS BALUSTRADE PROFIL PROFILO BALAUSTRÉ INOX 316L *5100/122 Ø 42,4 mm	inox s.s.	L	5,8 m	Ø42,4x1,5	€/m
--	--------------	---	-------	-----------	-----

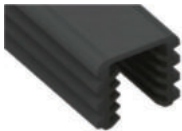

GOMA VIDRIO 12-13,52 MM CAOUTCHOUC POUR LE VERRE RUBBER FOR GLASS GOMMA PER VETRO *5107/10N 12-13,52 mm	Cau		12-13,52 mm		€/m
---	-----	--	-------------	--	-----

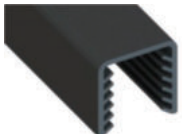

GOMA VIDRIO 16-19 MM CAOUTCHOUC POUR LE VERRE RUBBER FOR GLASS GOMMA PER VETRO *5108/10N 16-19 mm	Cau		16-19 mm		€/m
---	-----	--	----------	--	-----



GOMA VIDRIO 21,52 MM CAOUTCHOUC POUR LE VERRE RUBBER FOR GLASS GOMMA PER VETRO *5109/10N 21,52 mm	Cau		21,52 mm		€/m
---	-----	--	----------	--	-----



UNIÓN TUBO 90° FIXATION 90° 90° JOINER GIUNTO 90° INOX duplex 2205 *5101/022 Ø 42,4 mm	inox s.s.		Ø 42,4 mm		€/u
---	--------------	--	-----------	--	-----



UNIÓN TUBO 180° FIXATION 180° 180° JOINER GIUNTO 180° INOX duplex 2205 *5102/022 Ø 42,4 mm	inox s.s.		Ø 42,4 mm		€/u
---	--------------	--	-----------	--	-----



TAPÓN FINAL PERFIL 5100 COUVERTURE FINAL PROFIL FINAL COVER PROFIL 5100 COPRITESTA PROFILO 5100 INOX duplex 2205 *5103/022 Ø 42,4 mm	inox s.s.		Ø 42,4 mm		€/u
---	--------------	--	-----------	--	-----



UNÓN PARED PERFIL 5100 FIXATION MUR PROFIL 5100 WALL PROFIL 5100 JOINER GIUNTO PARTE PROFILO 5100 INOX duplex 2205 *5104/022 Ø 42,4 mm	inox s.s.		Ø 42,4 mm		€/u
---	--------------	--	-----------	--	-----



PEGAMENTO COLLE GLUE RETAINING COMPUOND COLLA *5106/000 50 ml			50 ml		€/u
---	--	--	-------	--	-----

# COTEK

BARANDILLAS DE VIDRIO - GARDE-CORPS DE VERRE  
GLASS BALUSTRADES - BALAUSTRÉ DI VETRO

BRUTO BRUT RAW GREZZO	NEGRO NOIR BLACK NERO	INOX INOX P.S.S. INOX	BR POLI S.S.S. LUC	INOX INOX S.S.S. INOX	SAT SAT SAT SAT
00	0N	22	28		

## BISAGRAS Y CERRADURAS PISCINAS



BISAGRA AUTOMÁTICA  
VIDRIO-VIDRIO 180°  
CHARNIÈRE AUTOMATIQUE  
VERRE-VERRE 180°  
AUTOMATIC HINGE  
GLASS-GLASS 180°  
CERNIERA AUTOMATICA  
VETRO-VETRO 180°  
INOX 316  
1448/022

inox s.s.	108x100	Ø16 mm	€/u
	12mm		



PESTILLO AUTOMÁTICO VID-VID 180°  
CIERRE IMANTADO DE SEGURIDAD  
VERROU AUTOMATIQUE VER-VER 180°  
FERMATURE MAGNÉTIQUE SÉCURITÉ  
BOLT GLASS-GLASS 180°  
WITH MAGNETIC SAFETY CLOSING  
SERRATURA AUTOMATICA VV 180°  
CHIUSURA MAGNETICA SICUREZZA  
INOX 316  
1480/022

inox s.s.	108x100	Ø12 mm	€/u
	12(16)mm		

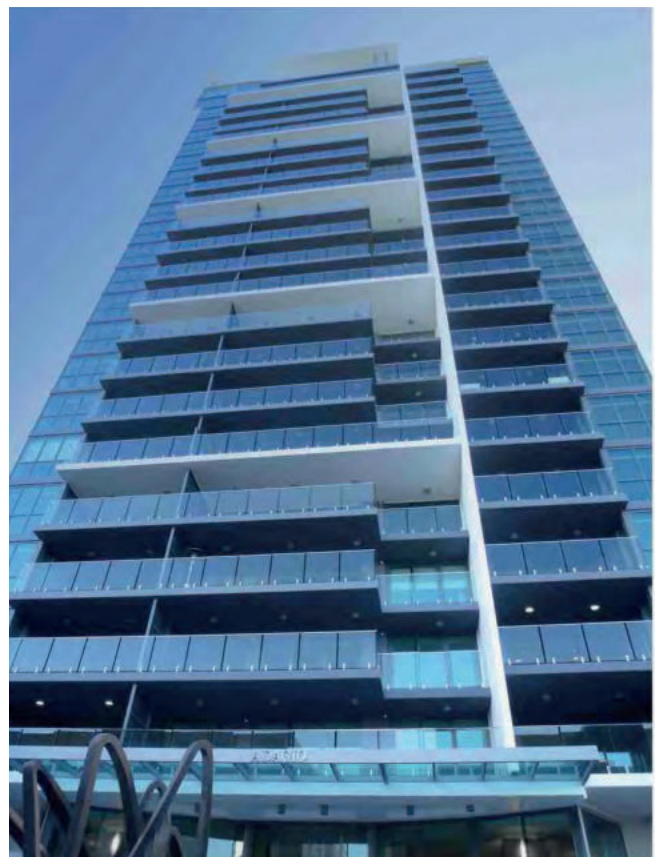
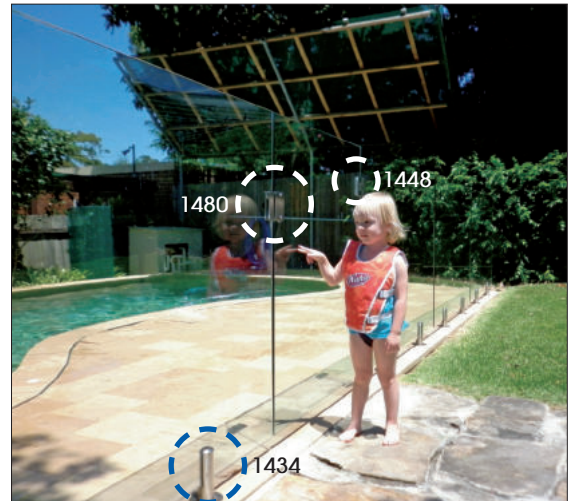

# COTEK - MARQUESINAS

HERRAJES ARQUITECTURA - ACCESSOIRES ARCHITECTURE  
ARCHITECTURE HARDWARE - ACCESSORI ARCHITETTURA

## MARQUESINAS

canopée en verre  
glass canopy -  
tettoia in vetro

Peso máximo recomendado: 60 kg/ conjunto 2 piezas  
vidrio de 12-16 mm (6+6, 8+8)

Peso massimo raccomandato: 60kg/gioco  
vetro 12-16 mm (6+6, 8+8)  
Weight max. recom: 60 Kg/set  
glass 12-16 mm (6+6, 8+8)  
Poids-limite: 60 kg/ensemble  
verre 12-16 mm (6+6, 8+8)



# COTEK - MARQUESINAS

HERRAJES ARQUITECTURA - ACCESSOIRES ARCHITECTURE  
ARCHITECTURE HARDWARE - ACCESSORI ARCHITETTURA

INOX BR	INOX SAT
INOX POL	INOX SAT
P.S.S.	S.S.S.
INOX LUC	INOX SAT
22	28

	<b>ANCLAJE VIDRIO-PARED</b> SUPPORT MUR-VERRE BRACKET WALL-GLASS UNIONE PARETE-VERRO <b>4340/022</b>	inox s.s.   12-16mm   €/u Ø 18 mm	○
	<b>ANCLAJE PARED-TIRANTE</b> SUPPORT MUR-TIRANT BRACKET WALL-TIE UNIONE PARETE-TIRANTE <b>4341/022</b>	inox s.s.   ∅4343-4305   €/u	○
	<b>ANCLAJE VIDRIO-TIRANTE</b> SUPPORT VERRE-TIRANT BRACKET GLASS-TIE UNIONE VETRO-TIRANTE <b>4342/022</b>	inox s.s.   12-16mm   €/u Ø 18 mm	○
	<b>TIRANTE Ø 16 MM</b> TIRANT TIE TIRANTE <b>4343/022 1 m</b>	inox s.s.   ∅4342-4341   €/u	○
	<b>TIRANTE Ø 16 MM</b> TIRANT TIE TIRAN <b>*4343/122 1,25 m</b>	inox s.s.   ∅4342-4341   €/u	○
	<b>ANCLAJE VIDRIO-PARED DOBLE</b> SUPPORT MUR-VERRE DOUBLE DOUBLE BRACKET WALL-GLASS UNIONE DOPPIA PARETE-VERRO <b>*4306/022</b>	inox s.s.   12-16mm   €/u Ø 18 mm	○
	<b>ANCLAJE VIDRIO-TIRANTE DOBLE</b> SUPPORT VERRE-TIRANT DOUBLE DOUBLEBRACKET GLASS-TIE UNIONE DOPPIA VETRO-TIRANTE <b>*4305/022</b>	inox s.s.   12-16mm   €/u Ø 18 mm	○
	<b>KIT 2 SOPORTES</b> 4340/022 2 u. 4341/022 2 u. 4342/022 2 u. 4343/022 2 u. <b>4344/022</b>	inox s.s.   max. rec. 120 cm   €/u	○

## KIT MARQUESINA

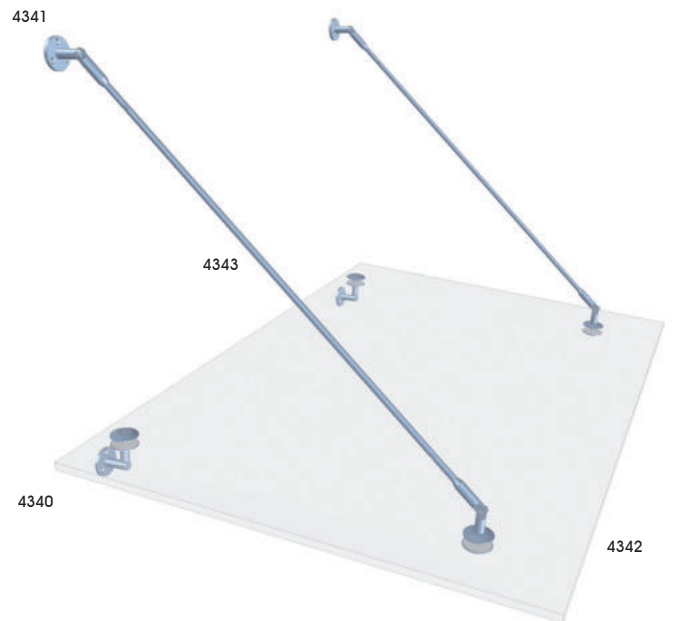

# metal.

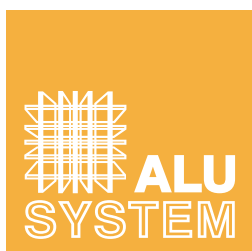

Herrajes  
para madera

Herrajes  
para vidrio

TARIFA 63

01/07/2023



## METAL - ÍNDEX

### COMPLEMENTOS PARA VIDRIO Y MADERA

#### 1- COMPLEMENTOS CORTE DEL VIDRIO 03

VENTOSAS Manipulación vidrio y madera

PEQUEÑA HERRAMIENTA PARA EL CORTE DEL VIDRIO

#### 2- COMPLEMENTOS PARA VIDRIO Y MADERA 05

CORREDERAS PARA VITRINAS  
 KARR1 vidrio 5/6 mm, KARR3 vidrio hasta 10 mm  
 ANGULOS Y US  
 CERRADURAS PARA VITRINAS  
 BISAGRAS PARA MUEBLES-VITRINAS  
 PORTAESTANTES  
 UNIÓN ESTANTERÍA VIDRIO  
 PASAMONEDAS  
 GUÍAS Y CARTELAS  
 COMPLEMENTOS ESPEJOS Y

#### 3- PUERTAS DE PASO DE MADERA Y FRENTES DE ARMARIOS 15

CORREDERAS PARA VITRINAS  
 KARR1 vidrio 5/6 mm  
 KARR3 vidrio hasta 10 mm

#### 4- CLICK. 19

Sistemas de perfilería de aluminio para mostradores y vitrinas

# VENTOSAS

VENTOUSES - SUCTION - VENTOSE

**VENTOSA TRIPLE**  
**VENTOUSE 3 COUPS**  
**SUCTION LIFTER 3 CUPS**  
**VENTOSA TRIPLE**  
**9190/000**



**VENTOSA DOBLE**  
**VENTOUSE 2 COUPS**  
**SUCTION LIFTER 2 CUPS**  
**VENTOSA DOPPIA**  
**9191/000**



**VENTOSA SENCILLA**  
**VENTOUSE 1 COUP**  
**SUCTION LIFTER 1 CUP**  
**VENTOSA SEMPLICE**  
**9194/000**



BRUTO BRUT RAW GREZZO	CR. BRILLO CHR. POLI BR. CHR CR. ILLUC.	CR. MATE CHR. M M. CHR CR. OPAC
00	32	31

Al	Ø 115 mm	€/u
V:	35 kg/u	H: 100 kg/u

○

Al	Ø 115 mm	€/u
V:	25 kg/u	H: 80 kg/u

○

Al	Ø 115 mm	€/u
V:	15 kg/u	H: 50 kg/u

○

BRUTO BRUT RAW GREZZO	CR. BRILLO CHR. POLI BR. CHR CR. ILLUC.	CR. MATE CHR. M M. CHR CR. OPAC
00	32	31

ABS	Ø 200 mm	€/u
V:	60 kg/u	H: 95 kg/u

○

**VENTOSA CON BOMBA DE VACÍO**  
**VENTOUSE À POMPE 1 COUP**  
**PUMP SUCTION LIFTER 1 CUP**  
**VENTOSA CON POMPA A VUOTO**  
 Maletin incluido  
**9198/000 ABS**



**! NUEVO**

**VENTOSA CON BOMBA DE VACÍO**  
**VENTOUSE À POMPE 1 COUP**  
**PUMP SUCTION LIFTER 1 CUP**  
**VENTOSA CON POMPA A VUOTO**  
 Maletin incluido  
**9195/000 LATÓN**  
**\*9197/000 ABS**

Fe	Ø 200 mm	€/u
V:	80 kg/u	H: 100 kg/u

○

○



## HERRAMIENTA CORTE

OUTILS DE COUPE  
CUTTING TOOLS  
UTENSILI TAGLIO



RULINA LUBRICADA  
COUPE-VERRE LUBRIFIÉ  
GLASS-CUTTER LUBRICATED  
TAGLIAVETRO LUBRIFICATO  
\*9048/000



RULINA SILBERSCHNITT  
COUPE-VERRE SILBERSCHNITT  
GLASS-CUTTER SILBERSCHNITT  
TAGLIAVETRO SILBERSCHNITT  
9060/000



RECAMBIO SILBERSCHNITT  
RECHARGE SILBERSCHNITT  
REFILL SILBERSCHNITT  
RICAMBI SILBERSCHNITT  
9061/000 CAJA 12 U.

ESCUADRA  
ÉQUERRE  
L SQUARE  
SQUADRA

9072/060 60 cm  
9072/100 105 cm  
9072/150 150 cm



BASTIDOR DE CORTE  
GABARIT DOUBLE À GLISSIÈRE  
SLIDING DOUBLE GAUGE  
SQUADRA TAGLIO SCOREVOLE

9070/040 40 cm  
9070/060 60 cm  
9070/080 80 cm  
9070/100 100 cm



CORTA CÍRCULOS CON VENTOSA  
TOURNETTE AVEC VENTOUSE  
ROUND CUTTER WITH SUCTION LIFT  
COMPASSO TAGLIO CON VENTOSA

9079/040 h.40cm  
9079/120 h.120cm



PLANTILLA CORTE CURVOS  
MODÈLE COUPE CURVILIGNE  
CURVILINEAR CUTTING TOOL  
CURVILINEA TAGLIO  
9080/000



TENAZA REMORDER  
PINCE À BEC PLAT À DÉTACHER  
FLATNOSE SNAP-OFF PLIERS  
TENAGLIA  
9085/200



TENAZA REMORDER  
PINCE À BEC PLAT À DÉTACHER  
FLATNOSE SNAP-OFF PLIERS  
TENAGLIA  
9085/180



TENAZA PICO DE LORO  
PINCE À BEC DE PERROQUET  
PARROT NOSE PLIERS  
TENAGLIA  
9086/000

## BROCAS DIAMANTADAS

BROCAS DIAMANTADAS  
FORETS DIAMANTÉS  
DIAMOND TIPPED DRILLS  
PUNTE DIAMANTATE



9107/040 4mm  
9107/050 5mm  
9107/060 6mm  
9107/070 7mm  
9107/080 8mm  
9107/090 9mm  
9107/100 10mm  
9107/120 12mm  
9107/140 14mm  
9107/160 16mm  
9107/180 18mm  
9107/260 26mm  
9107/360 36mm  
9107/380 38mm  
9107/400 40mm  
9107/460 46mm  
9107/550 55mm

PARA OTRAS MEDIDAS CONSULTAR.

## HERRAMIENTA CORTE

OUTILS DE COUPE  
CUTTING TOOLS  
UTENSILI TAGLIO

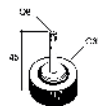

ADAPTADOR TALADRO CONVENCIONAL  
ADAPTEUR DE FORET CONVENTIONNEL  
CONVENTIONAL DRILL ADAPTER  
ADATTATORE TRAPANO CONVENZIONALE  
\*9005/00N



GAFAS SEGURIDAD  
LUNETTES DE PROTECTION  
GOGGLES  
OCCHIALI DI SICUREZZA  
\*9117/000



LÁPIZ  
CRAYON  
PENCIL  
MATITA

9120/0V ROJO, ROUGE, RED, ROSSO  
9120/0B AZUL, BLEU, BLUE, BLU  
9120/0G AMARILLO, JAUNE, YELLOW, GIALLO



ROTULADOR  
MARQUEUR  
FELT PEN  
PENNARELLO

9122/0V ROJO, ROUGE, RED, ROSSO  
9122/0N NEGRO, NOIR, BLACK NERO



PASTILLA AFILADORA BROCAS DIAMANTADAS  
PIERRES À AVIVER LES FORETS  
BIT BRIGHTENING STONE  
PIETRA AFFILATRICE DI PUNTE DIAMANTATE  
9110/000

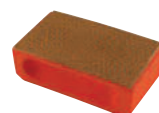

TACO DIAMANTADO  
RABOT DIAMANTÉE POUR POÇANGE MANUEL  
DISPOSABLE FOAM DIAMOND PLANE FOR FAND SANDING  
PIASTRA DIAMANTATA PER LEVIGATURA A MANO  
9082/120  
9082/220

## DISCOS Y BANDAS



DISCO VERDE SUPER FUERTE  
DISQUE VERT TRÈS GROS  
DISK GREEN VERY STRONG  
DISCO VERDE EXTRA FORTE

\*9008/220 g.220



DISCO NEGRO FUERTE  
DISQUE NOIR GROS  
DISK BLACK STRONG  
DISCO NERO FORTE

\*9008/06N g.60  
\*9008/08N g.80  
\*9008/12N g.120  
\*9008/22N g.220  
\*9008/32N g.320



BANDAS 2000x100 mm  
BANDE ABRASIVE 2000x100 mm  
ABRASIVE BELT 2000x100 mm  
NASTRO ABRASIVO 2000x100 mm

\*9009/060 g.60  
\*9009/080 g.80  
\*9009/220 g.220  
\*9009/320 g.320

**KARR 1**

**PARA VIDRIO DE 5-6 mm**

**ALTURA PUERTA HASTA 1,8 m Ó 10 kg/COJINETE**  
**VERRE 5-6 mm, HAUTEUR MAX. 1,8 m OU 10 kg/CHARLOT**  
**GLASS 5-6 mm, HEIGHT MAX. 1,8 m OR 10 kg/ROLLER**  
**VETRO 5-6 mm, ALTEZZA MASSIMA 1,8 m O 10 kg/CUSCINETTO**

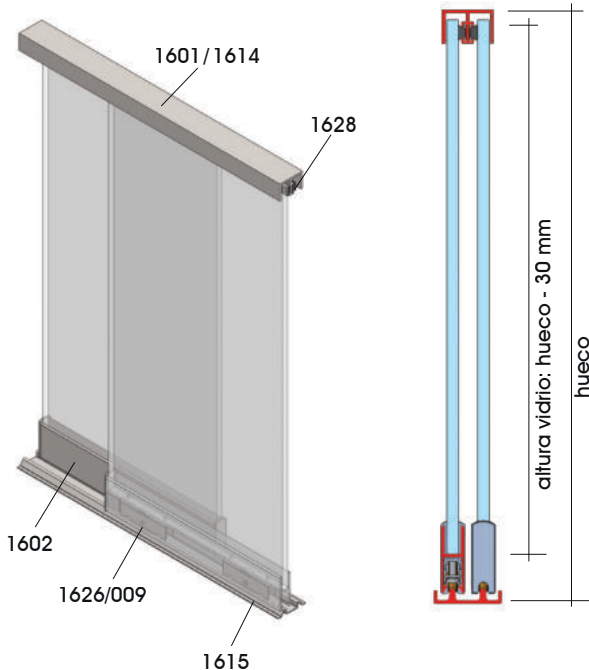
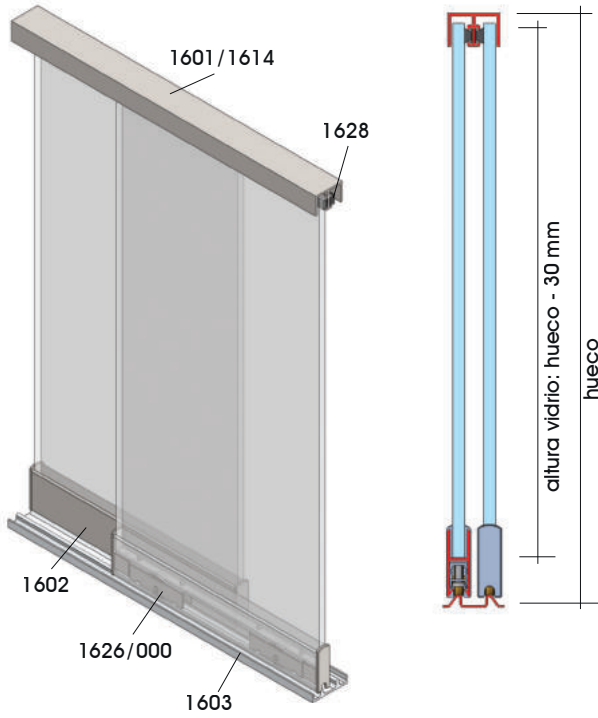

	PL. M ALU. M ALL. NAT	ORO DORÉ GOLD DOR. OP	M M M OP	BLANCO BLANC WHITE BIANCO	NEGRO NOIR BLACK NERO	COLOR COULEUR COLOR COLORE	BRUTO BRUT RAW GREZZO					
	01	03	0B	0N	0P	00						
<b>SUPERIOR DOBLE FELPA</b> COULISSE HAUTE DOBLE UPPER DOUBLE TRACK GUIDA SUPERIOR DOPPIA <b>1614/1..</b>	Al	L	5 m	∞	1628			€/m				
<b>SUPERIOR FELPA</b> COULISSE HAUTE DOBLE UPPER DOUBLE TRACK GUIDA SUPERIOR DOPPIA <b>*1601/1..</b>	Al	L	5 m	∞	1628			€/m				
<b>CASACA VIDRIO</b> PROFIL VERRE PROFILE GLASS PROFILO VETRO <b>1602/1..</b>	Al	L	5 m	∞	5-6 mm			€/m				
<b>CARRIL INFERIOR DOBLE</b> RAIL DOBLE INFERIEUR LOWER DOUBLE RAIL BINARIO DOPPIO INF. <b>1603/1..</b>	Al	L	5 m	∞	1626/009			€/m				
<b>CARRIL INFERIOR DOBLE</b> RAIL DOBLE INFERI LOWER DOUBLE RAIL BINARIO DOPPIO INF. <b>1615/128</b>	inox s.s.	L	5 m	∞	1626/000			€/m				
<b>PALA TIRADOR</b> EMBOUIT MET. + POIGNÉE METALIC END-CAP + PULL COPRITESTA MET. + MANIG. <b>1624/0..</b>	Zn							€/u				
<b>COJINETE HIERRO</b> GALET ACIER METALLIC ROLLER PATTINO METAL. SCORREV. <b>1626/000</b>	Fe	CuZn	15 kg/u	∞	1615			€/u				
<b>PALA METÁLICA</b> EMBOUIT METAL METALLIC END-CAP COPRITESTA METALLICO <b>1627/0..</b>	Fe							€/u				
<b>PALA PLÁSTICO NEGRO</b> EMBOUIT PLASTIQUE NOIR BLACK PLASTIC END-CAP COPRITESTA PLAST.NERO <b>1627/009</b>	plas							€/u				
<b>FELPA</b> BROSSER BRUSH FELPA <b>1628/109</b>	plas		325 m					€/m				
<b>GOMA CASACA</b> CAOUTCHOUC VERRE GLASS RUBBER GOMMA VETRO <b>1644/00N</b>	plas	L	5 mm	∞	125 m			€/m				
<b>UÑERO</b>												
<b>UÑERO ADHESIVO</b> POIGNÉE ADHESIVE ADHESIVE DOOR PULL MANIGLIA ADESIVA <b>1625/009</b>	plas	transp.						€/u				

# KARR 3

## PARA VIDRIO HASTA 10 mm

ALTURA PUERTA HASTA 2.5 m Ó 25 kg/COJINETE  
 VERRE MAX. 10 mm, HAUTEUR MAX. 2,5 m OU 25 kg/CHARLOT  
 GLASS MAX. 10 mm, HEIGHT MAX. 2,5 m OR 25 kg/ROLLER  
 VETRO MASS. 10 mm, ALTEZZA MASSIMA 2,5 m O 25 kg/CUSCINETTO

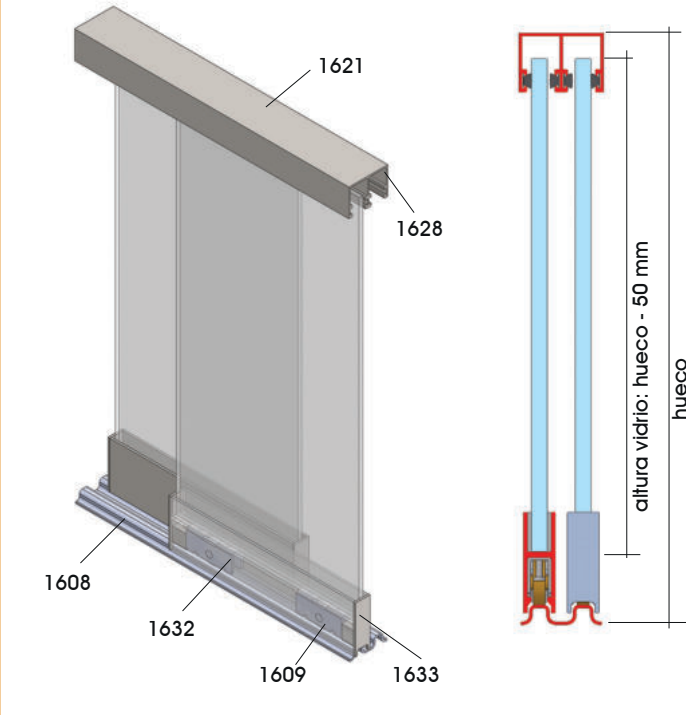

	PL. M ALU. M ALL. NAT	ORO DOR.	M M OP	BLANCO WHITE BIANCO	NEGRO BLACK NERO	COLOR COLOR COLORE	BRUTO RAW GREZZO					
	01	03	0B	0N	0P	00						
<b>CARRIL SUPERIOR SIMPLE</b> COULISSE HAUTE UPPER SIMPLEE TRACK GUIDA SUPERIOR SEMPLICE 1607/1..	Al	5 m	20x15x20x2					€/m				
<b>CARRIL SUPERIOR SIMPLE</b> COULISSE HAUTE UPPER SIMPLEE TRACK GUIDA SUPERIOR SEMPLICE 1640/1..	Al	5 m	30x18x30x2					€/m				
<b>SUPERIOR DOBLE FELPA</b> COULISSE HAUTE DOBLE UPPER DOUBLE TRACK GUIDA SUPERIOR DOPPIA 1621/1..	Al	5 m	∞ 1628					€/m				
<b>CASACA VIDRIO</b> PROFIL VERRE PROFILE GLASS PROFILO VETRO 1608/1..	Al	5 m	max.10 mm					€/m				
<b>CARRIL INFERIOR DOBLE</b> RAIL DOBLE INFERI LOWER DOUBLE RAIL BINARIO DOPPIO INF. 1609/128	inox s.s.	5 m						€/m				0
<b>COJINETE HIERRO</b> GALET ACIER METALLIC ROLLER PATTINO METAL. SCORREV 1632/000	Fe	25 kg/u						€/u				0
<b>PALA METÁLICA</b> EMBOUT METAL METALLIC END-CAP COPRITESTA METALLICO 1633/0..	Fe							€/u				0
<b>FELPA</b> BROSSER BRUSH 1628/109	plas	325 m						€/m				0

# CORREDERA PLÁSTICO

PORTE COULISSANTE EN PLASTIQUE  
PLASTIC SLIDING DOOR  
SCORREVOLE PLASTICA

PLÁSTICO PLASTIQUE PLASTIC PLASTICA	COLOR COULEUR COLOR COLORE
09	0P

**SUPERIOR DOBLE**  
COULISSE HAUTE DOBLE  
UPPER DOUBLE TRACK  
GUIDA SUPERIOR DOPPIA

plac		2 m		4 mm	15,5x11	€/m
------	---	-----	---	------	---------	-----

1682/10P MARRÓN, BRUN, BROWN, MARRONE  
1681/109 TRANSP.

**CARRIL INFERIOR DOBLE**  
RAIL DOBLE INFERIEUR  
LOWER DOUBLE RAIL  
BINARIO DOPPIO INF.

plac		2 m		4 mm	15,5x6	€/m
------	---	-----	---	------	--------	-----

1684/10P MARRÓN, BRUN, BROWN, MARRONE  
1683/109 TRANSP.

# ÁNGULOS Y "US"

PROFILES "L" ET "U"  
"L" AND "U" PROFILES  
PROFILI "L" E "U"

**ÁNGULO 15x15 mm**  
PROFIL EN "L" 20X20  
PROFIL "L" SHAPE 20X20  
PROFILO ANGOLARE 20X20  
1650/1..

Al		6,4 m	15x15x1,5 mm		€/m
----	---	-------	--------------	--	-----

**ÁNGULO 20x20 mm**  
PROFIL EN "L" 20X20  
PROFIL "L" SHAPE 20X20  
PROFILO ANGOLARE 20X20  
1651/1..

Al		5 m	20x20x1,5 mm		€/m
----	---	-----	--------------	--	-----



**ÁNGULO 25x25 mm**  
PROFIL EN "L" 25X25  
PROFIL "L" SHAPE 25X25  
PROFILO ANGOLARE 25X25  
1652/1..

Al		5 m	25x25x1,5 mm		€/m
----	---	-----	--------------	--	-----



**ÁNGULO 30x30 mm**  
PROFIL EN "L" 30X30  
PROFIL "L" SHAPE 30X30  
PROFILO ANGOLARE 30X30  
1653/1..

Al		5 m	30x30x1,5 mm		€/m
----	---	-----	--------------	--	-----



**"U" 10x10x10 mm**  
PROFIL EN "U" 10X10X10  
PROFIL "U" SHAPE 10X10X10  
PROFILO "U" 10X10X10  
1656/1..

Al		5 m	10x10x10x1,5		6 mm	€/m
----	---	-----	--------------	---	------	-----



**"U" 12x12x12 mm**  
PROFIL EN "U" 12X12X12  
PROFIL "U" SHAPE 12X12X12  
PROFILO "U" 12X12X12  
1657/1..

Al		6 m	12x12x12x1,5		8 mm	€/m
----	---	-----	--------------	---	------	-----



**"U" 15x15x15 mm**  
PROFIL EN "U" 15X15X15  
PROFIL "U" SHAPE 15X15X15  
PROFILO "U" 15X15X15  
1659/1..

Al		5 m	15x15x15x1,5		10 mm	€/m
----	---	-----	--------------	---	-------	-----

**"U" 20x15x20 mm**  
PROFIL EN "U" 20X15X20  
PROFIL "U" SHAPE 20X15X20  
PROFILO "U" 20X15X20  
1607/1..

Al		5 m	20x15x20x2		10 mm	€/m
----	---	-----	------------	---	-------	-----

**"U" 30x18x30 mm**  
PROFIL EN "U" 30X18X30  
PROFIL "U" SHAPE 30X18X30  
PROFILO "U" 30X18X30  
1640/1..

Al		5 m	30x18x30x2		12 mm	€/m
----	---	-----	------------	---	-------	-----

# CERRADURA VITRINAS

SERRURES POUR VETRINES  
GLASS SHOWCASES LOCKS  
SERRATURE PER VETRINE

CR. BRILLO CH-R. POLI BR. CHR CR. LUC.	CR. MATE CHR. M M. CHR CR. OPAC	CR. ORO CH-R. DOR GOLD. C CR. ORO
32	31	33

**CERRADURA LÁPIZ**  
SERRURE VERRE AVEC TRAU  
LOCK FOR DRILLED GLASS  
SERRATURA VETRO FORATO

1500/032 MISMA LLAVE  
même comb. keyed alike stessa chiave  
1500/132 DISTINTA LLAVE  
comb. variée, differ key, chiave distinta



**CERRADURA DE SERRETA**  
SERRURE CRÉMAILLÈRE AMOVIBLE  
RATCHET LOCK  
SERRATURA CREMAGLIERA

1502/032 DISTINTA LLAVE  
comb. variée, differ key, chiave distinta  
1501/032 MISMA LLAVE  
même comb. keyed alike stessa chiave



**CERRADURA PULSADOR**  
SERRURE PORTES COULISSANTES  
SLIDING DOOR LOCK  
SERRATURA PER SCORREVOLI

1497/0.. MISMA LLAVE  
même comb. keyed alike stessa chiave



**CERRADURA PALA**  
SERRURE PORTES COULISSANTES  
SLIDING DOOR LOCK  
SERRATURA PER SCORREVOLI

1504/0.. MISMA LLAVE  
même comb. keyed alike stessa chiave

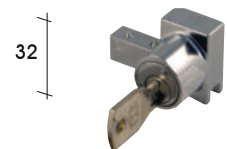

**CERRADURA PALA**  
SERRURE PORTES COULISSANTES  
SLIDING DOOR LOCK  
SERRATURA PER SCORREVOLI

1528/0.. MISMA LLAVE  
même comb. keyed alike stessa chiave

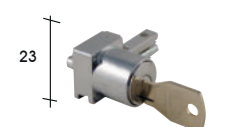

**CERRADURA VITRINA**  
SERRURE AVEC TRAU  
DRILLED GLASS LOCK  
SERRATURA VETRO FORATO

1505/032 MISMA LLAVE  
même comb. keyed alike stessa chiave



**CERRADURA PUERTA BATIENTE**  
SERRURE PORTE BATTANTE  
SWINGING DOOR LOCK  
SERRATURA PORTA BATTENTE

1495/032 MISMA LLAVE  
même comb. keyed alike stessa chiave



**CONTRACERRADURA VIDRIO SIN MUESCA**  
GAÛCHE VERRE SANS ENCOCHE  
GLASS STRIKE WITHOUT CUTOUT  
CONTROSERRATURA VETRO SENZA TACCA

1491/032





**CERRADURA 2 PUERTAS BATIENTES**  
SERRURE 2 PORTES BATTANTE  
SWINGING 2 DOORS LOCK  
SERRATURA 2 PORTE BATTENTI

1496/032 MISMA LLAVE  
même comb. keyed alike stessa chiave



Zn		6 mm		Ø 16	€/u
----	---	------	---	------	-----

∞ KARR 1 - KARR 2



Zn		4-8 mm			€/u
----	---	--------	---	--	-----



Zn					€/u
----	---	--	--	--	-----

Zn					€/u
----	---	--	--	--	-----

Zn					€/u
----	---	--	--	--	-----

Zn		5-6 mm		Ø 26	€/u
----	---	--------	---	------	-----

Zn		4-6 mm			€/u
----	---	--------	---	--	-----

Zn		4-6 mm			€/u
----	---	--------	---	--	-----

∞ 1495

Zn		4-6 mm			€/u
----	---	--------	---	--	-----

## COMPL. MUEBLES

ACCESSOIRES POUR MEUBLES  
FURNITURE FITTINGS  
ACCESSORI PER MOBILI

### BISAGRAS SIN MUESCA O TALADRO

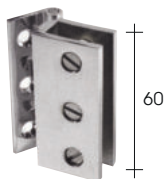

**BISAGRA PARED-VIDRIO**  
**CHARNIÈRE MUR-VERRE**  
**HINGE WALL-GLASS**  
**CERNIERA PARETE-VERRO**  
**1950/032**

Cu	4-8 mm	5 kg/u	€/u
60x32	0°-90°		



**BISAGRA VIDRIO-VIDRIO 180°**  
**CHARNIÈRE VERRE-VERRE 180°**  
**HINGE GLASS-GLASS 180°**  
**CERNIERA VETRO-VERRO 180°**  
**1951/032**

Cu	4-8 mm	5 kg/u	€/u
60x57	0°-90°		

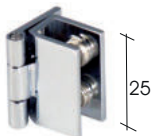

**BISAGRA PARED-VIDRIO**  
**CHARNIÈRE MUR-VERRE**  
**HINGE WALL-GLASS**  
**CERNIERA PARETE-VERRO**  
**1963/032**

Cu	4-6 mm	2,5 kg/u	€/u
25x20	0°-90°		



**BISAGRA VIDRIO-VIDRIO 90°**  
**CHARNIÈRE VERRE-VERRE 90°**  
**HINGE GLASS-GLASS 90°**  
**CERNIERA VETRO-VERRO 90°**  
**1964/032**

Cu	4-6 mm	2,5 kg/u	€/u
25x16	0°-180°		



**BISAGRA VIDRIO-VIDRIO 180°**  
**CHARNIÈRE VERRE-VERRE 180°**  
**HINGE GLASS-GLASS 180°**  
**CERNIERA VETRO-VERRO 180°**  
**1953/032**

Cu	4-6 mm	2,5 kg/u	€/u
25x57	0°-180°		



**SET BISAGRA CAZOLETA**  
**CHARNIÈRE DE PIVOTEMENT**  
**PIVOTING HINGE**  
**CERNIERA CARDINE**  
**1954/032 sup.**  
**1955/032 inf.**  
**JUEGOS DE 2 UNIDADES**  
**JEUX DE 2 UNITÉS**  
**SET 2 PIÈCES**  
**SET 2 PEZZI**

Cu	6-8 mm	12 kg/2u	€/u
40x27			



**SET BISAGRA CAZOLETA**  
**CHARNIÈRE DE PIVOTEMENT**  
**PIVOTING HINGE**  
**CERNIERA CARDINE**  
**1522/022 IZQUIERDA**  
**gauche/left/sinistra**  
**1523/022 DERECHA**  
**droite/right/destra**  
**JUEGOS DE 2 UNIDADES**  
**JEUX DE 2 UNITÉS**  
**SET 2 PIÈCES**  
**SET 2 PEZZI**

inox s.s.	4-6 mm	40x22	€/u
12 kg/2u			



**SET IMÁN**  
**JEU D'AIMANTS**  
**MAGNET SET**  
**SET DI MAGNETI**  
**1509/022**

inox s.s.	4-6 mm		€/u
-----------	--------	--	-----

**! NUEVO**

## COMPL. MUEBLES

ACCESSOIRES POUR MEUBLES  
FURNITURE FITTINGS  
ACCESSORI PER MOBILI

### BISAGRAS CON MUESCA O TALADRO



**BISAGRA PIVOTANTE**  
**CHARNIÈRE DE PIVOTEMENT**  
**PIVOTING HINGE**  
**CERNIERA CARDINE**  
**1961/032 sup.**  
**1962/032 inf.**  
**JUEGOS DE 2 UNIDADES**  
**JEUX DE 2 UNITÉS**  
**SET 2 PIÈCES**  
**SET 2 PEZZI**

Zn	6-8 mm	18 kg/2u	€/u
65x40			



**BISAGRA PARED-VIDRIO**  
**CHARNIÈRE MUR-VERRE**  
**HINGE WALL-GLASS**  
**CERNIERA PARETE-VERRO**  
**1957/032**

Cu	6-8 mm	10 kg/u	€/u
43x40	0°-90°		Ø 12



**BISAGRA VIDRIO-VIDRIO 180°**  
**CHARNIÈRE VERRE-VERRE 180°**  
**HINGE GLASS-GLASS 180°**  
**CERNIERA VETRO-VERRO 180°**  
**1958/032**

Cu	6-8 mm	10 kg/u	€/u
40x80	0°-90°		Ø 12



**BISAGRA GOLPE ARREMETIDA**  
**CHARNIÈRE ANGULAIRE**  
**CORNER HINGE**  
**CERNIERA A SCATTO**  
**1956/032**

Cu	6-8 mm	10 kg/u	€/u
46x48	0°-90°		Ø 12



**SET BISAGRA GOLPE ARREMETIDA**  
**CHARNIÈRE ANGULAIRE**  
**CORNER HINGE**  
**CERNIERA A SCATTO**  
**1516/0.. DERECHA**  
**droite/right/destra**  
**1517/0.. IZQUIERDA**  
**gauche/left/sinistra**  
**JUEGOS DE 2 UNIDADES**  
**JEUX DE 2 UNITÉS**  
**SET 2 PIÈCES**  
**SET 2 PEZZI**

Zn	4-5 mm	40x30	€/u
10 kg/2u			



**BISAGRA GOLPE ARREMETIDA**  
**INTERMEDIA**  
**CHARNIÈRE CENTRALE**  
**CENTRAL HINGE**  
**CERNIERA A SCATTO INTERMEDIA**  
**1452/0..**  
**JUEGOS DE 2 UNIDADES**  
**JEUX DE 2 UNITÉS**  
**SET 2 PIÈCES**  
**SET 2 PEZZI**

Zn	4-5 mm	30x30	€/u
10 kg/2u			

# PORTAESTANTES

PINCES POUR TABLETTES  
BRACKETS FOR SHELVES  
PORTAMENSOLE

CR. BRILLO CHR. POLI BR. CHR. CR. LUC.	CR. ORO CHR. DOR GOLD. C CR. ORO	BLANCO BLANC WHITE BIANCO	NEGRO NOIR BLACK NERO	COLOR COULEUR COLOR COLORE
32	33	0B	0N	0P



**PORTAESTANTE MEDIALUNA**  
PINCES POUR TABLETTES  
BRACKETS FOR SHELVES  
PORTAMENSOLE  
1513/0.. 6 mm

Zn	6-8-10mm		49x25	€/u
----	----------	--	-------	-----

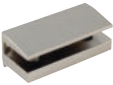

**PORTAESTANTE RECTANGULAR**  
PINCES POUR TABLETTES  
BRACKETS FOR SHELVES  
PORTAMENSOLE  
\*1510/0.6mm

Zn	6-8-10mm		55x25	€/u
----	----------	--	-------	-----



**PORTAESTANTE MEDIA BOLA**  
PINCES POUR TABLETTES  
BRACKETS FOR SHELVES  
PORTAMENSOLE  
\*1512/0..

Zn	5-6 m		40x22	€/u
----	-------	--	-------	-----



**SOPORTE ESTANTES CILINDRO**  
PINCES POUR TABLETTES  
BRACKETS FOR SHELVES  
PORTAMENSOLE  
1538/0.. 6mm

Zn	6 mm		Ø 15x27	€/u
----	------	--	---------	-----



1539/0.. 8/10mm

Zn	8-10 mm		Ø 195x27	€/u
----	---------	--	----------	-----

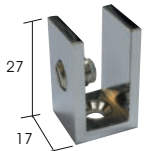

**SOPORTE VIDRIO BASE PLANA**  
PINCE VERRE BASE PLATE  
GLASS CLAMP FLAT BASE  
MORSETTO VETRO BASE PIANA

1540/032 6-10 mm

inox s.s.	6-10		17x27	€/u
-----------	------	--	-------	-----



**PORTEESTANTE VIDRIO-VIDRIO**  
Vidrio 8-10 mm (base)  
6-8 mm (estante)  
TAQUET SUPPORT BRACKET  
Verre avec trous 8-10 mm  
Verre tablette 6-8 mm  
FITTING FOR GLASS SHELF  
Glass drilled 8-10 mm  
Glass shelf 6-8 mm  
ACCESSORIO PER MENSOLA VETRO  
Vetro con foro 8-10 mm  
Vetro mensola 6-8 mm  
4959/032

Cu	Ø10 mm		6-8mm	8-10mm	€/u
----	--------	--	-------	--------	-----

# PORTAESTANTES

PINCES POUR TABLETTES  
BRACKETS FOR SHELVES  
PORTAMENSOLE

CR. BRILLO CHR. POLI BR. CHR. CR. LUC.	CR. MATE CHR. M M. CHR. CR. OPAC
32	31



**PINZA PELICANO GRANDE**  
PINCE "PELICAN XL"  
BRACKET "PELICAN XL"  
PORTAMENSOLE "PELICANO XL"  
91/032  
91/031

Zn	6-35mm	€/u
105x75		

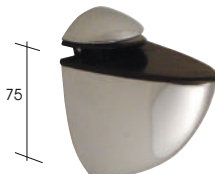

**PINZA PELICANO MEDIANA**  
PINCE "PELICAN M"  
BRACKET "PELICAN M"  
PORTAMENSOLE "PELICANO M"  
94/032  
94/031

Zn	6-29mm	€/u
75x55		



**PINZA PELICANO PEQUEÑA**  
PINCE "PELICAN S"  
BRACKET "PELICAN S"  
PORTAMENSOLE "PELICANO S"  
92/032  
92/031

Zn	6-12mm	€/u
40x36		

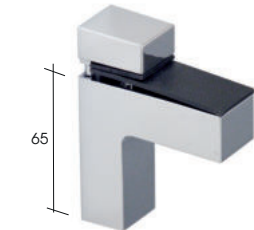

**PINZA CUADRADA GRANDE**  
PINCE CARRÉE  
SQUARE BRACKET  
MORSETTO QUADRATO  
\*95/032

Zn	6-42mm	€/u
75x66		

# COMPLEMENTOS

ACCESSOIRES  
ACCESSORIES  
COMPLEMENTI

CR. BRILLO CHR. POLI BR. CHR. CR. LUC.	INOX BR INOX POLI P. S. S. INOX LUC
32	22

# DISTANCIADOR RÓTULOS



**DISTANCIADOR VIDRIO AVELANADO**  
ESPACEUR AVEC TROU FRAISÉE  
SPACER WITH COUNTERSUNK DRILL  
SEPARATORE CON FORO SVASATO  
1930/032

Cu	8-10mm	Ø 19	€/u
	Ø 8 mm	∠ Ø 19 mm	

# UNIÓN ESTANTERÍA

ENSEMBLES ÉTAGÈRES - JOINTS SHELVES - UNIONI SCAFFALI

CR. BRILLO CHR. POLI BR. CHR. CR. LUC.	CR. MATE CHR. M M. CHR. CR. OPAC
32	31



**ESCUADRA METÁLICA 3 VIDRIOS**  
SUPPORT ANGULAIRE 3 VERRES  
ANGULAR SUPPORT 3 GLASSES  
SUPPORTO ANGOLARE 3 VETRI  
1518/032

Fe	Ø 5	max.8mm	€/u
----	-----	---------	-----



**ESCUADRA METÁLICA 2 VIDRIOS**  
SUPPORT ANGULAIRE 2 VERRES  
ANGULAR SUPPORT 2 GLASSES  
SUPPORTO ANGOLARE 2 VETRI  
1519/032

Fe	Ø 5	max.8mm	€/u
----	-----	---------	-----



**APOYO FINAL ESTANTE**  
TAQUET ÉTAGÈRE FINALE  
FINAL SHELF SUPPORT  
SUPPORTO FINALE MENSOLA  
1520/L32

Cu	Ø 8	max.10mm	€/u
----	-----	----------	-----



**APOYO INTERMEDIO 2 ESTANTES**  
TAQUETS INTERMÉDIAIRE 2 ÉTAGÈRES  
INTERMEDIATE 2 SHELVES SUPPORT  
SUPPORTO INTERMEDIO 2 MENSOLE  
1521/L32

Cu	Ø 8	max.10mm	€/u
----	-----	----------	-----

# SEPARADOR MOSTRADORES



**DISTANCIADOR VIDRIO AVELANADO**  
ESPACEUR AVEC TROU FRAISÉE  
SPACER WITH COUNTERSUNK DRILL  
SEPARATORE CON FORO SVASATO  
1925/0..102mm  
\*1926/0..152mm

Cu	8-10mm	Ø 19	€/u
	Ø 8 mm	∠ Ø 19 mm	

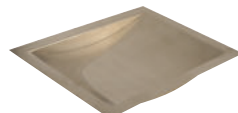

**PASAMONEDAS**  
PASSAMONNAIE  
MONEY HATCH  
PASSAMONETE  
1665/022

inox s.s.	41x31x4 cm		255x350	€/u
-----------	------------	--	---------	-----

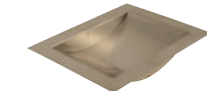

**PASAMONEDAS**  
PASSAMONNAIE  
MONEY HATCH  
PASSAMONETE  
1666/022

inox s.s.	26x21x4 cm		155x205	€/u
-----------	------------	--	---------	-----



**PASAMONEDA BLINDADO**  
PASSAMONNAIE BLINDÉ  
ARMOURED MONEY HATCH  
PASSAMONETE BLINDATO  
1667/022

inox s.s.	41x31x7 cm		255x350	€/u
-----------	------------	--	---------	-----



**GUÍAS Y CARTELAS**

CRÉMAILLÈRES ET SUPPORTS  
UPRIGHTS AND BRACKETS  
PROFILI CREMAGLIERA E MENSOLE

PL. M ALU. M ALL. NAT	ORO M DORÉ M GOLD M DOR. OP	BLANCO BLANC WHITE BIANCO	NEGRO NOIR BLACK NERO	COLOR COULEUR COLOR COLORE	CR. MATE CHR. M M. CHR CR. OPAC
01	03	0B	0N	0P	31

**COMPL. MUEBLES**

ACCESSOIRES POUR MEUBLES  
FURNITURE FITTINGS  
ACCESSORI PER MOBILI

PL. M ALU. M ALL. NAT	ORO M DORÉ M GOLD M DOR. OP	BLANCO BLANC WHITE BIANCO	NEGRO NOIR BLACK NERO	CR. BRILLO CHR. POI BR. CR CR. ILLC.	CR. MATE CHR. M M. CHR CR. OPAC
01	03	0B	0N	32	31

**CREMALLERAS KADÍ**



4574



4566



4576

**"SILUETTE" PLEGADA**



4691 - 4692



4693 - 4694

**GUÍAS EMPOTRABLES**

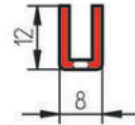

GUÍA EMPOTRABLE SENCILLA  
CRÉMAILLEIRE SIMPLE PERFORATION  
ENCAISSABLE FRONTALEMENT  
SINGLE SLOT RACK INSERTABLE  
FRONTALLY  
CREMAGLIERA FORATURA SEMPLICE  
INCASSABILE FRONTALMENTE  
4605/2..

COMPATIBLES CON SISTEMA KADÍ  
COMPATIBLE AVEC SYSTEME KADÍ  
COMPATIBLE WITH KADÍ SYSTEM  
COMPATIBLE CON IL SISTEMA KADÍ

Fe	2,5 m	∞ KADÍ		€/U
----	-------	--------	--	-----

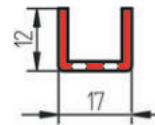

GUÍA EMPOTRABLE DOBLE  
CRÉMAILLEIRE DOUBLE PERFORATION  
ENCAISSABLE FRONTALEMENT  
DOUBLE SLOT RACK INSERTABLE  
FRONTALLY  
CREMAGLIERA FORATURA DOPPIA  
INCASSABILE FRONTALMENTE  
4610/2..

COMPATIBLES CON SISTEMA KADÍ  
COMPATIBLE AVEC SYSTEME KADÍ  
COMPATIBLE WITH KADÍ SYSTEM  
COMPATIBLE CON IL SISTEMA KADÍ

Fe	2,5 m	∞ KADÍ		€/U
----	-------	--------	--	-----

**GUIAS 867**

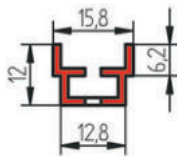

CREMALLERA  
CRÉMAILLEIRE  
UPRIGHT  
CREMAGLIERA  
\*867/2..

Al	2 m	∞ 1089-1090		€/U
----	-----	-------------	--	-----

--	--	--	--	--



CARTELAS  
SUPPORTS  
BRACKETS  
MENSOLE

- \*1089/15...15 cm
- \*1089/20...20 cm
- \*1089/25...25 cm
- \*1089/30...30 cm
- \*1089/35...35 cm

Al	∞ 867-1087-1100		€/U
----	-----------------	--	-----

--	--	--	--	--



CARTELA INCLINADA 30°  
SUPPORT INCLINÉ 30°  
BRACKET INCLINED 30°  
MENSOLA INCLINATA 30°

- \*1090/30...30 cm
- \*1090/40...40 cm

Al	∞ 867-1087-1100		€/U
----	-----------------	--	-----

--	--	--	--	--



ALETA PLÁSTICO  
CAVALIER DOUBLE  
DOUBLE SADDLED  
CAVALIERE DOPPIO  
\*997/00N

plas	∞ 1089-1900		€/U
------	-------------	--	-----

--	--	--	--	--

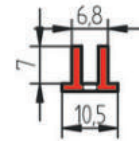

GUÍA PARA EMPOTRAR  
CRÉMAILLEIRE POUR INCASSÉ  
RACK TO BE EMBEDDED  
CREMAGLIERA DA INCASSO  
\*4611/2..

Al	2 m	∞ 4612		€/U
----	-----	--------	--	-----

--	--	--	--	--



APOYO ESTANTE  
TAGUET ÉTAGÈRE  
SHELF SUPPORT  
SUPPORTO MENSOLA  
\*4612/0..

Al	∞ 4611		€/U
----	--------	--	-----

--	--	--	--	--



APOYO ESTANTE  
TAGUET ÉTAGÈRE  
SHELF SUPPORT  
SUPPORTO MENSOLA  
\*1402/033

Cu	∅14		€/U
----	-----	--	-----

--	--	--	--	--



APOYO ESTANTE  
TAGUET ÉTAGÈRE  
SHELF SUPPORT  
SUPPORTO MENSOLA  
\*1403/009

plas	13x11		€/U
------	-------	--	-----

--	--	--	--	--



GOTA SILICONE ADHESIVA  
SUPPORT AHÉSIF EN SILICONE  
SILICONE ADHESIVE BASE  
GOCCIA ADESIVA DI SILICONE  
1405/009

plas	∅10		€/U
------	-----	--	-----

--	--	--	--	--



VENTOSA TRANSPARENTE  
VENTOUSE  
SUCTION  
VENTOSA  
2556/009

plas	∅14		€/U
------	-----	--	-----

--	--	--	--	--



VENTOSA TRANSPARENTE  
VENTOUSE  
SUCTION  
VENTOSA  
319/009

plas	∅20		€/U
------	-----	--	-----

--	--	--	--	--

# DIS-PLAY



**PERFIL TAPA**  
PROFIL COUVERTURE  
COVER PROFILE  
PROFILO COPERTINA

4020/101

**PERFIL BASE**  
PROFIL BASE  
BASE PROFILE  
PROFILO BASE

4021/100

**MUELLE**  
RESSORT  
SPRING  
MOLLA

Se recomienda 4-5 u/m

4022/028

**ESCUADRA ENSAMBLE**  
ÉQUERRE DE ASSEMBLAGE  
ASSEMBLING CORNER BRACKET  
STAFFA UNIONE D'ANGOLO

4023/034

**TAPA ESQUINA**  
COUVERCLE DE COIN  
CORNER COVER  
COPERTINA ANGOLO

\*4024/032

PL. M ALU. M ALL. NAT	BRUTO BRUT GREZZO	INOX INOX INOX	BR POLI P. S. S.	CR. BRILLO CR. POLI CR. LUC.	ZINCADO PL. ZNK ZNK PL. ZNCATO
01	00	22	32	34	
Al	L	5 m	32x14 mm		€/m
Al	L	5 m	32x14 mm		€/m
inox s.s.	∞	4000			€/u
Fe					€/u
plas					€/u

# PATAS MESAS

PIEDS POUR TABLES  
LEGS FOR TABLES  
GAMBE PERTAVOLI



**PATA CÓNICA PARA MESSAS DE VIDRIO**  
CON DISCO PEGAMENTO "UV"  
PIED CONIQUE POUR TABLE EN  
VERRE AVEC DISQUE ADHÉSIF "UV"  
CONICAL LEG FOR GLASS TABLE WITH  
PLATE "UV" GLUE  
GAMBA CONICA PER TAVOLO DI VETRO  
CON PIASTRA PER INCOLLAGGIO "UV"

Alto: 700 mm (nivelable)  
Hauteur: 700 mm (réglable)  
Height: 700 mm (adjustable)  
Altezza: 700 mm (regolabile)

9143/028

JUEGOS DE 4 U

JEUX 4 UNITÉS

SET 4 PIECES

SET 4 PEZZI

CR. BRILLO CR. POLI BR. CR CR. LUC.	BLANCO BLANC WHITE BIANCO	NEGRO NOIR BLACK NERO	C. SAT. NK SAT. NK. C SAT. NK. C C. SAT. NK
32	0B	0N	38
Fe	inox s.s.	Ø60	j70-72 cm
			UV
			€/u

# COMPLEMENTOS

ACCESSOIRES - ACCESSORIES - COMPLEMENTI

CR. BRILLO CR. POLI BR. CR CR. LUC.	BLANCO BLANC WHITE BIANCO	ZINCADO PL. ZNK ZNK PL. ZNCATO	INOX BR INOX POLI P. S. S. INOX LUC
32	0B	34	22

## COMPLEMENTOS ESPEJOS

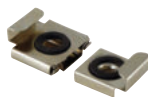

**GRAPA INOX DE MUELLE**  
PALTES INOX AVEC RESSORT  
STAINLESS STEEL CLAMP WITH SPRING  
GRAPPA INOX CON MOLLA

1664/022

PRECIO DE:

1 SET DE 4 UNIDADES

inox s.s.	set 4 u.		€/u



**SOPORTE ESPEJO Y FOCO**  
SUPPORT MIRROR ET SPOT  
MIRROR AND SPOT SUPPORT  
SUPPORTO SPECCHIO E SPOT

1542/034 60cm

1548/034 10cm

Fe			€/u



**CINTA ADHESIVA 2 CARAS**  
RUBAN ADHÉSIF DOUBLE FACE  
DOUBLE FACED ADHESIVE TAPE  
NASTRO BIADESIVO

1545/00B 12X0,8

1546/00B 19X0,8

plas	66 m		€/u

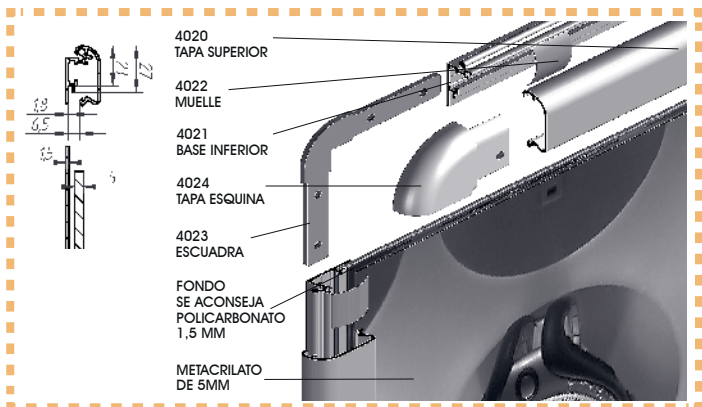

# CERRADURAS DIGITALES

INOX SAT	PLÁSTICO
INOX SAT	PLÁSTICO
S.S.S.	PLÁSTICO
INOX SAT	PLÁSTICO
28	09



CERRADURA CON PASSWORD / RFID - BLUETOOTH  
 SERRURE AVEC MOT DE PASSE/RFID-BLUETOOTH  
 LOCK WITH PASSWORD / RFID - BLUETOOTH  
 SERRATURA CON PASSWORD / RFID - BLUETOOTH  
 \*4259/028

Incluye 3 tarjetas RFID  
 APP bluetooth RFID password



FUNDA SILICONA, WATERPROOF  
 BÔÎTER EN SILICONE, IMPERMÉABLE  
 SILICONE CASE, WATERPROOF  
 CASSA IN SILICONE, IMPERMEABILE  
 \*4259/S09



TARJETA RFID  
 CARTE RFID  
 RFID CARD  
 SCHEDA RFID  
 \*4259/C09

inox s.s.	Zn	CE	€/u
PLA			€/u
PLA			€/u

# METAL - HYDRO

HERRAJES PARA PUERTAS - QUINCAILLERIE DE PORTE  
 DOORS PATCH FITTINGS - ACCESSORI PER PORTE



BISAGRAS HIDRAULICAS PARA PUERTAS DE MADERA  
 3 PIEZAS (2 HIDRAULICAS, 1 LIBRE)  
 CHARNIÈRES HYDRAULIQUES POUR PORTES EN BOIS  
 3 PIÈCES (2 HYDRAULIQUES, 1 GRATUITÉ)  
 HYDRAULIC HINGES FOR WOODEN DOORS  
 3 PIECES (2 HYDRAULIC, 1 FREE)  
 CERNIERE IDRAULICHE PER PORTE IN LEGNO  
 3 PEZZI (2 IDRAULICI, 1 GRATUITO)  
 1532/001 Der  
 1533/001 Izq

charnière mur ferme-porte hydraulique réglable  
 wall hinge hydraulic spring floor adjustable  
 cerniera parete chiudiporta idraulico regolabile

PLATA MATE	ALU. MAT	ALL. NATURALE
01		
Al		€/u

## GUÍA DE DIRECCIÓN DE BISAGRAS

HIDRÁULICA

madera 38 mm  
 Peso max. 40 kg/puerta  
 ancho max. 100 cm  
 Para uso interior  
 Testada 2M ciclos

CONSULTAR DISPONIBILIDAD

CERRADURAS INTELIGENTES - SMART-LOCK

**! NUEVO**

DESCRIPCIÓN DEL PRODUCTO

LLAVE DE AJUSTE LUZ INDICADOR  
 PESTAÑA DE BLOQUEO  
 CAJA DE BATERÍA PLACA DE BLOQUEO

CONSULTAR DISPONIBILIDAD

CERRADURAS INTELIGENTES - SMART-LOCK PARA CAJONES

INTELIGENTE  
 SEGURO  
 CONVENIENTE  
 BAJA ENERGÍA

**! NUEVO**

## BISAGRA HIDRÁULICA Guía de instalación (AluH)

90°RETENCIÓN  
 80°EMPIEZA A CERRARSE  
 CERRAMIENTO HIDRAULICO  
 170°BLOQUEO  
 25°  
 0° CERRAMIENTO  
 ANGULO MAS ABIERTO

1 CORTE EN MADERA

2 Instalar la bisagra SUPERIOR e INFERIOR

3 Instale la BISAGRA HIDRAULICA en la mitad de la puerta

4 Ajuste de la POTENCIA Y VELOCIDAD

MODO DE AJUSTE

VELOCIDAD Y FUERZA EN EL LADO DE LA BISAGRA

HACIA LA DERECHA EL VALOR  
 HACE QUE LA PUERTA SE  
 CIERRE LENTAMENTE ABAJO

HACIA LA IZQUIERDA EL VALOR  
 HACE QUE LA PUERTA SE  
 CIERRE MAS RAPIDO

HACIA LA DERECHA EL VALOR  
 HACE QUE LA PUERTA SE  
 CIERRE CON MAS FUERZA

HACIA LA IZQUIERDA EL VALOR  
 HACE QUE LA PUERTA SE  
 CIERRE CON MENOS FUERZA

# METAL-FACILPLUS

PUERTA CORREDERA PARA ARMARIO EMPOTRADO  
 PORTE COULISSANTE ARMOIRE ENCASTRÉE  
 BUILT-IN WARDROBE SLIDING DOOR  
 SCORREVOLE PER ARMADI IMPOTRATI

BLANCO BLANC WHITE BIANCO	PL. M ALU. M ALL. M ALL. NAT	NEGRO NOIR BLACK NERO	BRUTO BRUT RAW GREZZO	COLOR COULEUR COLOR COLORE
0B	01	0N	00	0P

Fe	∞ 1720		€/u
----	--------	--	-----

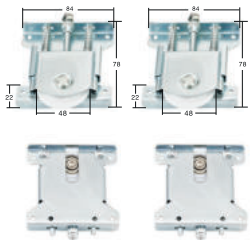

SET COJINETES SUPERIOR +  
 BUFFER AUTOCIERRE  
 SET GALETES HAUTES + AMORTISSEUR  
 SET UPPER ROLLER + SELF-CLOSING SYSTEM  
 SET CUSCINETTO + AMORTIZZATORE  
**1736/034**



CARRIL INFERIOR DOBLE  
 RAIL DOBLE INFERIEUR  
 LOWER DOUBLE RAIL  
 BINARIO DOPPIO INF.  
**1724/1..**

Al	5 m	62x6 mm	37,25 mm	€/m
----	-----	---------	----------	-----



STOP INTERIOR CARRIL  
 STOP CHARLOT  
 STOP ROLLER  
 STOP CUSCINETTO  
**1731/000**

Fe	∞ 1724		€/u
----	--------	--	-----

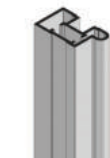

PERFIL LATERAL  
 PROFILE LATERAL DOOR  
 DOOR LATERAL PROFILE  
 PROFILO LATERAL PORTA  
**1720/101**

Al	Consultar	34x20 mm	10 mm	€/m
----	-----------	----------	-------	-----

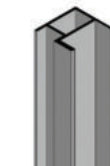

PERFIL LATERAL  
 PROFILE LATERAL DOOR  
 DOOR LATERAL PROFILE  
 PROFILO LATERAL PORTA  
**1726/10..**

Al	5,2 m	20x20 mm	16 mm	€/m
----	-------	----------	-------	-----

Consultar



FELPA ADHESIVA  
 BRUSSEUR ADHESIF  
 ADHESIVE BRUSH  
 FELPA ADESIVA  
**1732/100**

plas	∞ 1720	75 m	€/m
------	--------	------	-----

# METAL - ARPLUS

PUERTAS CORREDERA - PORTES COULISSANTS  
 SLIDING DOORS - PORTE SCORREVOLI

## SISTEMA DE PUERTAS TIPO "CLÁSICO"

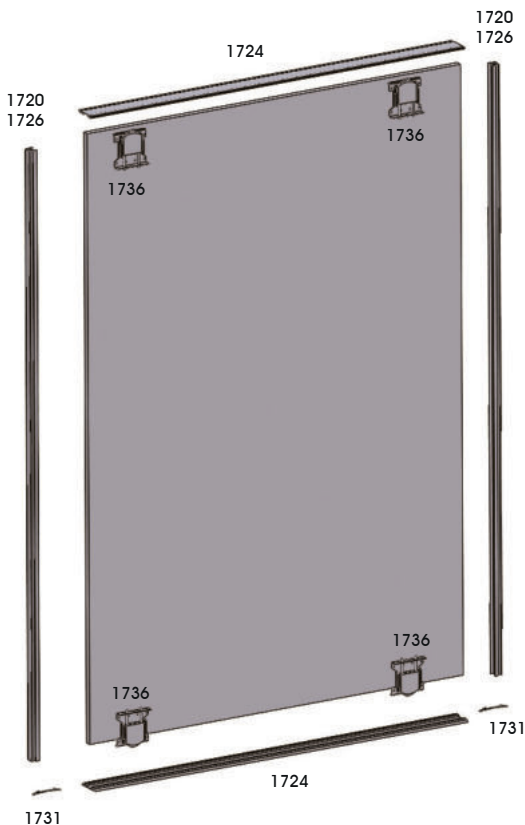
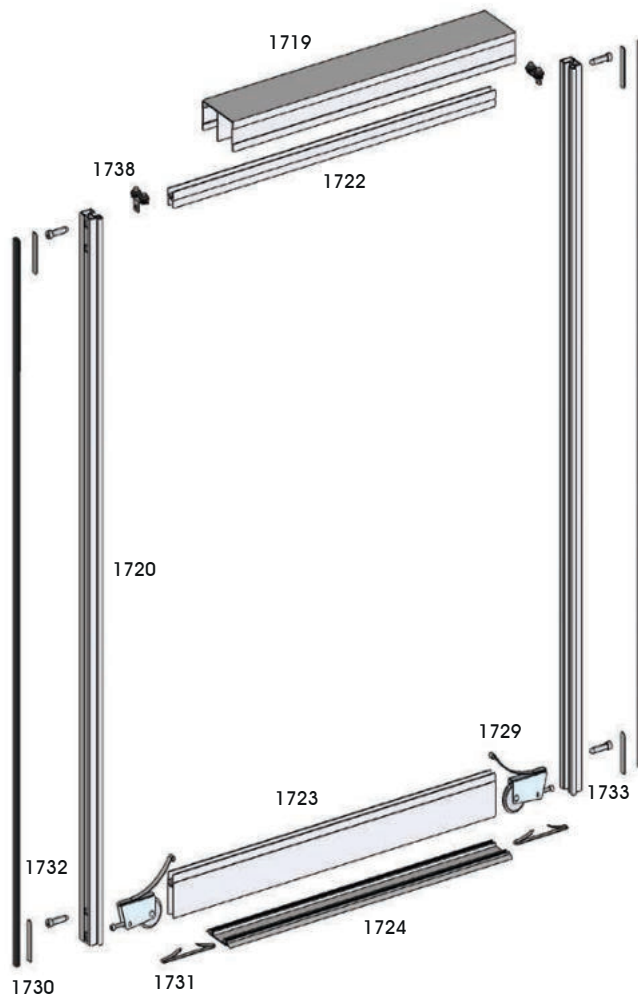



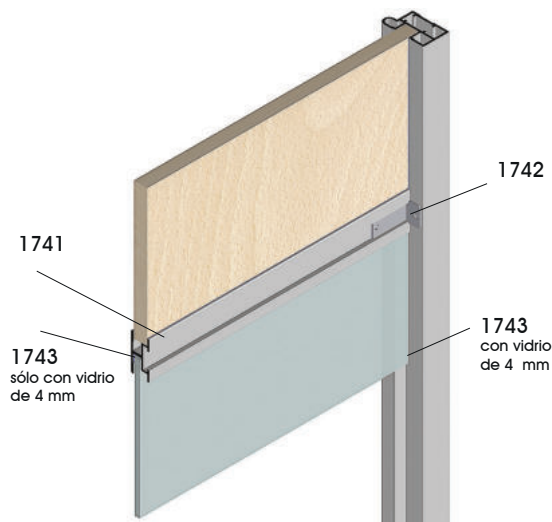





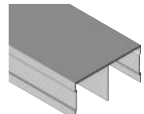



## SISTEMA DE PUERTAS TIPO "JAPONESA"



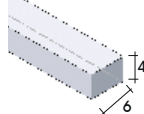
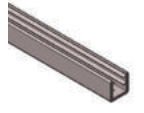

## METAL - ARPLUS

PUERTAS CORREDERA - PORTES COULISSANTS  
SLIDING DOORS - PORTE SCORREVOLI

	BLANCO BLANC BIANCO	PL. M ALU. M ALL. M	ORO M DORÉ M DOR. OP	NEGRO NOIR NERO	BRUTO BRUT GREZZO	COLOR COULEUR COLORE
	0B	01	03	0N	00	0P
 LATERAL PUERTA PROFILE LATERAL DOOR DOOR LATERAL PROFILE PROFLO LATERAL PORTA 1720/1..	Al	Consulter	34x20 mm	10 mm	€/m	
 SUPERIOR DOBLE COULISSE HAUTE BOBLE UPPER DOUBLE TRACK GUIDA SUPERIOR DOPPIA 1719/1..	Al	5 m	81x40 mm	37,25 mm	€/m	
 CASACA SUPERIOR PROFILE DOOR HAUTE UPPER DOOR PROFILE PROFLO SUPERIORE PORTA 1722/1..	Al	5 m	22x11 mm	10 mm	€/m	
 CASACA SUPERIOR PROFILE DOOR HAUTE UPPER DOOR PROFILE PROFLO SUPERIORE PORTA 1723/1..	Al	5 m	57x11 mm	10 mm	€/m	
 CARRIL INFERIOR DOBLE RAIL DOBLE INFERIEUR LOWER DOUBLE RAIL BINARIO DOPPIO INF. 1724/1..	Al	5 m	62x6 mm	37,25 mm	€/m	
 COJINETE SUPERIOR GALET HAUTE UPPER ROLLER CUSCINETTO SCORREV. 1738/009	Fe	∞ 1720			€/u	
 COJINETE GALET ACIER METALLIC ROLLER PATTINO METAL. SCORREV. 1729/000	Fe	20 kg/u	∞ 1723		€/u	
 STOP INTERIOR CARRIL STOP CHARLOT STOP ROLLER STOP CUSCINETTO 1731/000	Fe	∞ 1724			€/u	
 TORNILLO VIS SCREW VITE 1730/000	Fe	∞ 1720-1723-1722			€/u	
 TAPÓN ADHESIVO BOUCHON ADHESIF HOLES ADHESIVE COVER COPERTINA FORI ADESIVA 1733/0..	plas	∞ 1720			€/u	
 PERFIL PARA "JAPONESA" PROFILE X PORTE "JAPANAIS" "JAPANESE" DOOR PROFILE PROFLO PORTA "GIAPPONESE" 1741/1..	Al	5 m	26x14 mm	6-10 mm	€/m	
 FELPA ADHESIVA BROSSER ADHESIF ADHESIVE BRUSH FELPA ADESIVA 1732/100	plas	∞ 1720	75 m		€/m	
 ENSAMBLE PARA "JAPONESA" ASSEMBLAGE PORTE "JAPANAIS" "JAPANESE" ASSEMBLY FISSAGGIO "GIAPPONESE" 1742/034	Fe	∞ 1720-1741			€/u	
 JUNQUILLO VETRO PERFIL POUR VERRE PROFILE FOR GLASS PROFLO PER VETRO *1743/109	plas	∞ 1720-1723-1722-1741			€/m	
 JUNQUILLO VETRO PERFIL POUR VERRE PROFILE FOR GLASS PROFLO PER VETRO *5060/109	plas	3 m	∞ 1741	4 mm	€/m	

## METAL - ARPLUS

PUERTAS CORREDERA - PORTES COULISSANTS  
SLIDING DOORS - PORTE SCORREVOLI

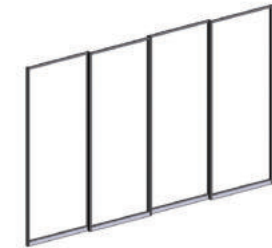
	BLANCO BLANC BIANCO	PL. M ALU. M ALL. M	ORO M DORÉ M DOR. OP	NEGRO NOIR NERO	BRUTO BRUT GREZZO	COLOR COULEUR COLORE
	0B	01	03	0N	00	0P
 2 PUERTAS 2 PORTES 2 DOORS 2 PORTE						
<b>ALTURA PUERTA CONSULTAR</b> HAUTEUR MAX. CONSULTER HEIGHT MAX. ASK ALTEZZA MASSIMA CONSULTARE						
<b>ANCHO HUECO</b> LARGEUR WIDTH LARGHEZZA						
1739/22. < 1,5 m	0	0	0	0	0	0
1739/32. 1,51 <-> 2 m	0	0	0	0	0	0
1739/42. 2,01 <-> 2,5 m	0	0	0	0	0	0
 3 PUERTAS 3 PORTES 3 DOORS 3 PORTE						
<b>ALTURA PUERTA CONSULTAR</b> HAUTEUR MAX. CONSULTER HEIGHT MAX. ASK ALTEZZA MASSIMA CONSULTARE						
<b>ANCHO HUECO</b> LARGEUR WIDTH LARGHEZZA						
1739/13. 1,50 <-> 2 m	0	0	0	0	0	0
1739/23. 2,01 <-> 2,5 m	0	0	0	0	0	0
1739/33. 2,51 <-> 3 m	0	0	0	0	0	0
1739/43. 3,01 <-> 3,5 m	0	0	0	0	0	0
 4 PUERTAS 4 PORTES 4 DOORS 4 PORTE						
<b>ALTURA PUERTA CONSULTAR</b> HAUTEUR MAX. CONSULTER HEIGHT MAX. ASK ALTEZZA MASSIMA CONSULTARE						
<b>ANCHO HUECO</b> LARGEUR WIDTH LARGHEZZA						
1739/14. < 3 m	0	0	0	0	0	0
1739/24. 3,01 <-> 3,5 m	0	0	0	0	0	0
1739/34. 3,51 <-> 4 m	0	0	0	0	0	0

# METAL - CANTÓN 80 KG

PUERTAS CORREDERA - PORTES COULISSANTS  
SLIDING DOORS - PORTE SCORREVOLI

## CANTÓN MADERA

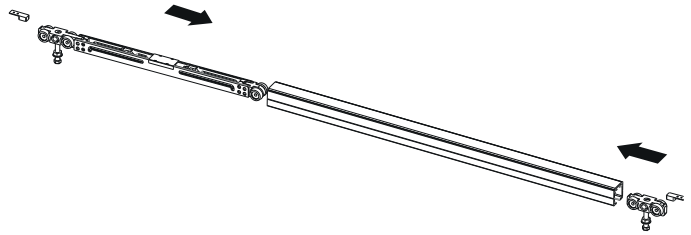

### MONTAJE A TECHO O PARED

EL CARRIL 5111 ESTÁ MECANIZADO CON UN TALADRO CADA 45 CM PARA SER FIJADO DIRECTAMENTE A LA PARED SIN NECESIDAD DE ESCUADRAS

- Montage au plafond ou au mur. Le profile supérieur 5111 est usinée avec des trous tous les 45 cm pour être fixée directement au mur sans avoir besoin de supports.
- Ceiling or wall mount, the track 5111 is machined with holes every 45 cm to be fixed directly to the wall without the need for brackets
- Montaggio a soffitto o a muro. La guida superiore 5111 è meccanizzata con fori ogni 45 cm per essere fissata alla parete senza necessità di supporti

### SECCIÓN PARA PUERTAS DE MADERA

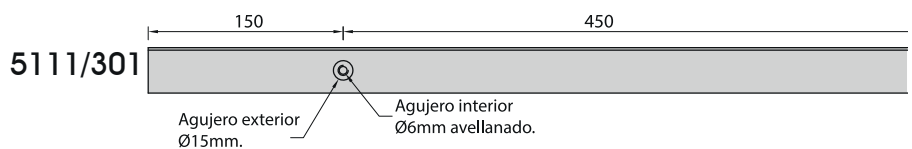
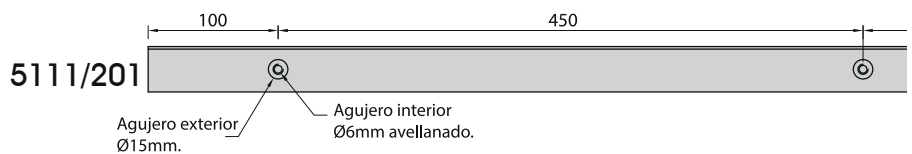
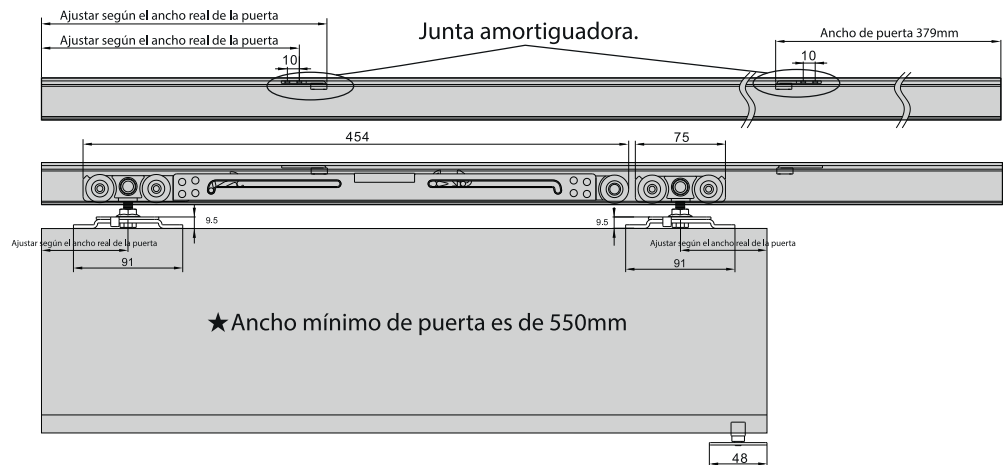
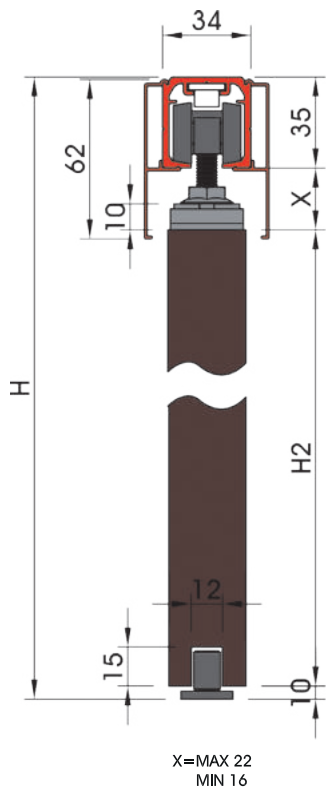

## METAL - CANTÓN 80 KG

PUERTAS CORREDERA - PORTES COULISSANTS  
SLIDING DOORS - PORTE SCORREVOLI



**CARRIL  
COULISSE HAUTE  
UPPER TRACK  
GUIDA SUPERIORE**  
5111/201 2 m  
5111/301 3 m



**PERFIL TAPA CARRIL  
PROFIL COUVERTURE COULISSE  
TRACK COVER PROFIL  
PROFILO COPERTINA GUIDA**  
5116/201 2 m  
5116/301 3 m



**SET PINZA MADERA  
PINCE POUR BOIS  
CLAMP FOR WOOD  
PINZA PER LEGNO**  
1 COJINETE + BUFFER AUTOCIERRE  
1 COJINETE SIN BUFER  
2 TOPES AUTOCIERRE PINZAS  
2 ANCLAKES PUERTAS MADERA  
1 GUÍA INFERIOR  
5115/001 CON BUFFER

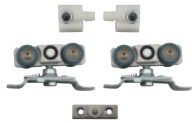

**KIT FRENOS (STOP) + GUÍAS SUELO  
KIT ARRÊT + GUIDE AU SOL  
KIT STOP + FLOOR GUIDE  
KIT STOP + GUIDA A PAVIMENTO**  
5122/012

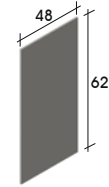

**TAPA LATERAL DE CARRIL  
COUVERTURE LATÉRAL DU RAIL  
TOP RAIL SIDE COVER  
COPERTURA LATERALE SUPERIORE**  
5117/001



**ÚNERO DOBLE ADHESIVO  
POIGNÉE DOUBLE ADHÉSIVE  
DOUBLE ADHESIVE PULL  
POMO DOPPIO ADHESIVO**  
4207/0..  
4207/0..



**GALGA MONATJE ÚNEROS  
GABARIT DE MONTAGE  
INSTALLATION TOOL  
SAGOMA AIUTO MONTAGGIO**  
4209/000

### PARA PUERTAS CORREDERAS DE VIDRIO - POUR PORTES COULISSANTES EN VERRE - FOR GLASS SLIDING DOORS - PER PORTE SCORREVOLI DI VETRO

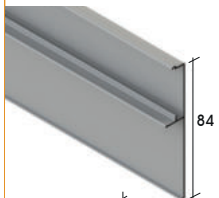

**PERFIL TAPA CARRIL  
PROFIL COUVERTURE  
TRACK COVER PROFIL  
PROFILO COPERTINA GUIDA**  
5112/201 2 m  
5112/301 3 m

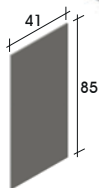

**TAPA LATERAL DE CARRIL  
COUVERTURE LATÉRAL DU PROFIL  
TOP RAIL SIDE COVER  
COPERTURA LATERALE SUPERIORE**  
5113/001



**SET PINZA PORTAVIDRIO  
PINCE POUR VERRE  
CLAMP FOR GLASS  
PINZA PER VETRO**  
1 COJINETE + BUFFER AUTOCIERRE  
1 COJINETE SIN BUFER  
2 TOPES AUTOCIERRE PINZAS  
2 PINZAS DE ALUMINIO  
1 GUÍA INFERIOR  
5110/001

CR. BRILLO CH. POLI BR. CH. P. CR. LUC.	PL. M ALU. M ALL. NAT	BRUTO BRUT RAW GREZZO	PLÁSTICO PLASTIQUE PLASTIC PLASTICA
32	01	00	09
Al	2/3 m	∞ 5111	€/u
Al	2 m	∞ 5111	€/u
Al	∞ 5116		€/u
Al	∞ 5116		€/u
INOX SAT INOX SAT S.S.S. INOX SAT	28	INOX BR INOX POLI P.S.S. INOX LUC	NEGRO NOIR BLACK NERO
	∅ 60	22	0N
Al inox s.s.			€/u
Al			€/u
Al	2/3 m	∞ 5111	€/u
Al		∞ 5112	€/u
Al Fe	8-10 mm		€/u
	80 kg/set		

## METAL - CANTÓN 80 KG

PUERTAS CORREDERA - PORTES COULISSANTS  
SLIDING DOORS - PORTE SCORREVOLI

PARA PUERTAS CORREDERAS DE MADERA - POUR PORTES COULISSANTES EN BOIS -  
FOR WOODEN SLIDING DOORS - PER PORTE SCORREVOLI IN LEGNO



5120/E21 2 m  
5120/E31 3 m

**KIT PUERTA CORREDERA PARA MADERA  
EMPOTRABLE EN EL TECHO  
KIT PORTE COULISSANTE BOIS AU PLAFOND  
KIT SLIDING DOOR RECESSED IN THE CEILING  
KIT PORTA SCORREVOLE INCASSATA NEL SOFFITTO**

5111/201-5111/301 1 u. carril  
5115/001 2 u. set pinzas para madera  
4207/001 1 u. únero

5121/P21 2 m  
5121/P31 3 m

**KIT PUERTA CORREDERA PARA MADERA A PARED  
KIT DE PORTE COULISSANTE BOIS AU MUR  
KIT SLIDING DOOR FIXED TO THE WALL  
KIT PORTA SCORREVOLE FISSATA A PARETE**

5111/201 1 u. carril  
5116/201 1 u. tapa carril  
5117/001 2 u. tapa lateral carril  
5115/001 2 u. set pinzas para madera  
4207/001 1 u. únero



**METAL - LIMA**  
 PUERTAS CORREDERA - PORTES COULISSANTES  
 SLIDING DOORS - PORTE SCORREVOLI

**METAL - LIMA**  
 PUERTAS CORREDERA - PORTES COULISSANTES  
 SLIDING DOORS - PORTE SCORREVOLI

NEGRO  
 NOIR  
 BLACK  
 NERO  
**0N**

€/u



**MADERA "LIMA"**

**HIERRO LACADO NEGRO**

- HASTA 90 KG POR PUERTA
- GROSOR PUERTA DE 33-43 MM
- SOLO MONTAJE A PARED
- SE VENDE EN KIT POR PUERTAS DE 2 m (NO RECORTABLE)



**KIT PUERTA CORREDERA MONTAJE A PARED**  
 KIT DE PORTE COULISSANTE FIXÉ AU MUR  
 SLIDING DOOR SET WALL MOUNTED  
 SET PORTA SCORREVOLE MONTATA A A PARETE  
**5390/20N**

- 1 u. **CARRIL ACERO**  
 COULISSE HAUTE - UPPER TRACK - GUIDA SUPERIORE
- 2 u. **COJINETES**  
 CHARLOT - ROLLER - CUSCINETTO
- 2 u. **STOP**  
 STOP CHARLOT - STOP ROLLER - STOP CUSCINETTO
- 5 u. **CONEXIÓN TUBO-PARED**  
 FIXATION TUBE-MUR - CONNEXION TUBE-WALL - CONNESSIONE TUBO-PARETE
- 1 u. **GUÍA INFERIOR**  
 GUIDAGE AU SOL - FLOOR GUIDE - GUIDA A PAVIMENTO
- 2 u. **PIEZAS ANTI-DESCARRILAMIENTO**  
 ÉPINGLE DE SÛREITÉ - SAFETY PIN - PERNO DI SICUREZZA
- 2 u. **AMORTIGUADOR CON RETENCIÓN**  
 AMORTISSEURS - DUMPERS SELF-CLOSING - AMORTIZZATORE

**ATENCIÓN - ATTENTION - ATTENZIONE**

- El carril no se puede cortar al estar mecanizado por los buffer amortiguadores
- Le rail ne peut pas être coupé lorsqu'il est usiné par les amortisseurs
- The rail can not be cut because machined for the dumpers selfclosing
- la guida non può essere tagliata perché meccanizzata per il fissaggio degli amortizzatori

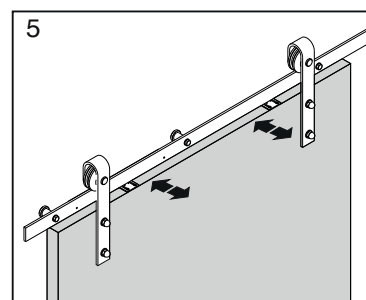
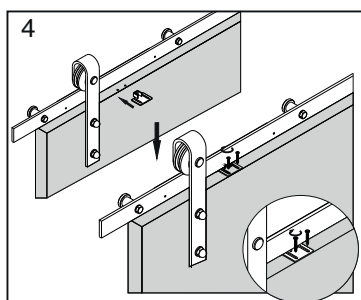
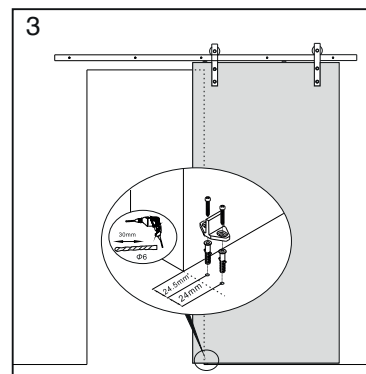
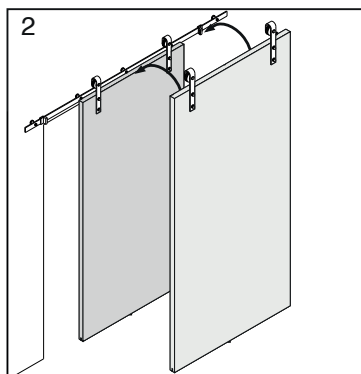
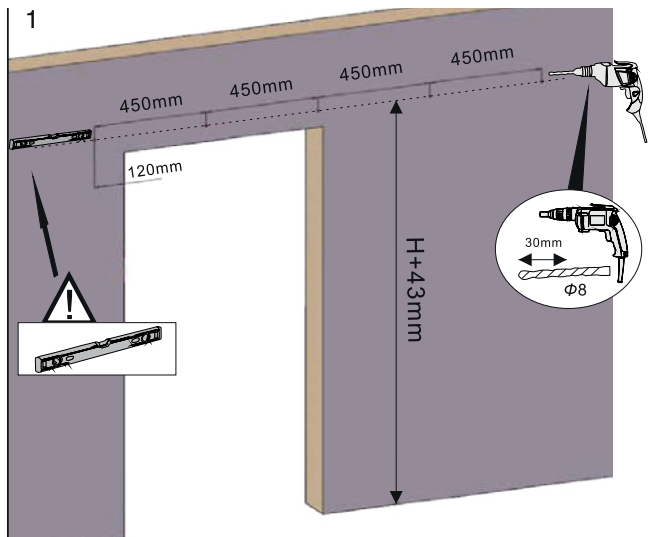
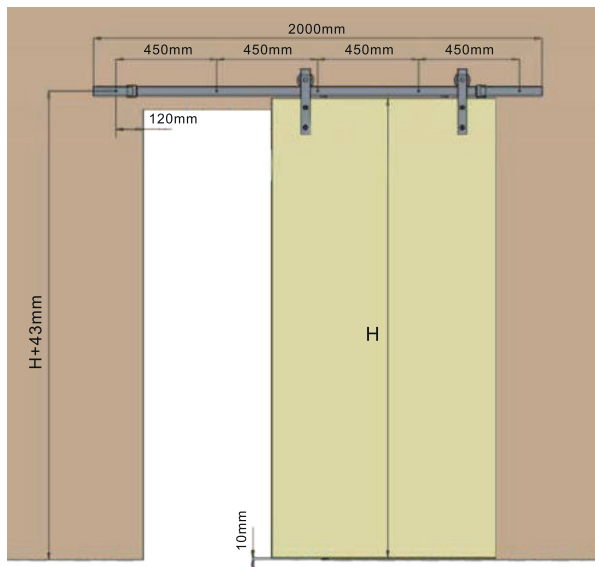



## METAL - MATEK

PUERTAS CORREDERA - PORTES COULISSANTS  
SLIDING DOORS - PORTE SCORREVOLI

## METAL - MATEK

PUERTAS CORREDERA - PORTES COULISSANTS  
SLIDING DOORS - PORTE SCORREVOLI

### MATEK



**Solo pared:**  
**Kit 2 mts.**  
**Kit 3 mts.**



COJINETE  
CHARLOT  
ROLLER  
CUSCINETTO  
**5363/028** plano



TUBO-CARRIL  
TUBE-COULISSE  
TUBE-TRACK  
TUBO-GUIDA  
**4350/328** 3 m  
**4350/228** 2 m



REMATE FINAL CARRIL  
BOUCHON COULISSE  
END-CAP TRACK  
COPRITESTA TUBO  
**236/0..**



GUÍA SUELO  
GUIDAGE AU SOL  
FLOOR GUIDE  
GUIDA A PAVIMENTO  
**5364/028**



STOP COJINETE  
STOP CHARLOT  
STOP ROLLER  
STOP CUSCINETTO  
**5356/028** DERECHA  
droite/right/destra  
**5357/028** IZQUIERDA  
gauche/left/sinistra



ANCLAJE CARRIL-PARED  
FIXATION MUR-COULISSE  
CONNEXION WALL-TRACK  
CONNESSIONE PARETE-GUIDA  
**4355/028**



CONEXIÓN TUBO-PARED  
FIXATION TUBE-MUR  
CONNEXION TUBE-WALL  
CONNESSIONE TUBO-PARETE  
**4353/028**



UÑERO DOBLE ADHESIVO  
POIGNÉE DOUBLE ADHESIVE  
DOUBLE ADHESIVE PULL  
POMO DOPPIO ADHESIVO  
**4207/0..**

PLÁSTICO PLASTIQUE PLASTIC PLASTICA	INOX INOX S.S.S.	SAT SAT INOX SAT	ZINCADO PL. ZNK ZNK PL. ZINCATO
09	28	34	
inox s.s.	L 2/3 m	Ø25x2,5	€/u
			o
	Ø 25		€/u
			o
inox s.s.	Ø 25		€/u
			o
inox s.s.	Ø 25		€/u
			o
inox s.s.	Ø 25		€/u
			o
inox s.s.	Ø 60		€/u
			o

### MONTAJE A PARED



**5365/228** 2 m

KIT PUERTA CORREDERA DE MADERA  
KIT PORTE COULISSANTE EN BOIS  
WOODEN SLIDING DOOR KIT  
KIT PORTA SCORREVOLE IN LEGNO

- 4350/228 1 u. tubo carril
- 236/009 2 u. tapas finales
- 4353/028 4 u. conexión tubo-pared
- 5356/028 1 u. stop cojinete derecho
- 5357/028 1 u. stop cojinete izquierdo
- 5363/028 2 u. cojinetes
- 5364/028 1 u. guiador suelo
- 4207/028 1 u. uñero doble adhesivo

**5365/328** 3 m

KIT PUERTA CORREDERA DE MADERA  
KIT PORTE COULISSANTE EN BOIS  
WOODEN SLIDING DOOR KIT  
KIT PORTA SCORREVOLE IN LEGNO

- 4350/328 1 u. tubo carril
- 236/009 2 u. tapas finales
- 4353/028 6 u. conexión tubo-pared
- 5356/028 1 u. stop cojinete derecho
- 5357/028 1 u. stop cojinete izquierdo
- 5363/028 2 u. cojinetes
- 5364/028 1 u. guiador suelo
- 4207/028 1 u. uñero doble adhesivo

o  
€/u

o  
€/u



**CLICK**

VITRINAS Y MOSTRADORES - VETRINES  
SHOWCASES - VETRINE

**SISTEMA DE PERFILES DE ALUMINIO PARA TODO TIPO DE VITRINAS Y MOSTRADORES**

Aluminum profile system for all types of showcases  
Système de profils en aluminium pour tous les types de vitrines  
Sistema di profili di alluminio per vetrine

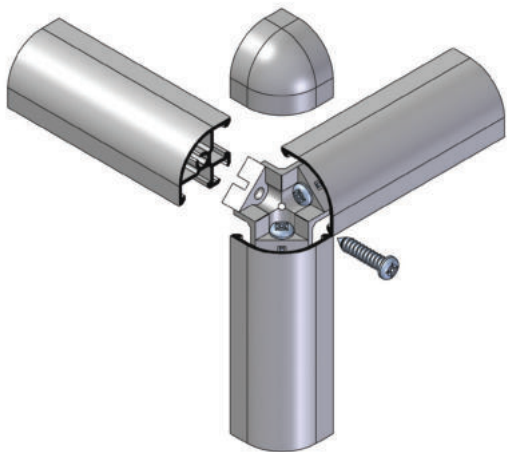

**VIDRIO SUPERIOR**  
VERRE SUPERIEUR  
UPPER GLASS  
VETRO SUPERIORE

**VIDRIOS FIJOS**  
VERRES FIXES  
FIXED GLASSES  
VETRI FISSILATERALI

**MADERA**  
BOIS  
WOOD  
LEGNO

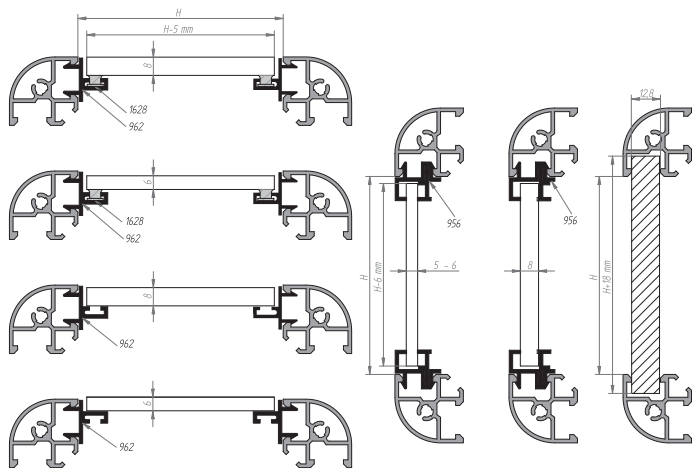

**CORREDERA PLÁSTICO**  
COULISSE EN PLASTIQUE  
PLASTIC SLIDING DOOR  
SCORREVOLE IN PLASTICA  
H. MAX.: 1,2 M

**CORREDERA ALUMINIO**  
COULISSE EN ALUMINIUM  
SLIDING DOOR IN ALUMINIUM  
SCORREVOLE IN ALLUMINIO  
H. MAX.: 2 M

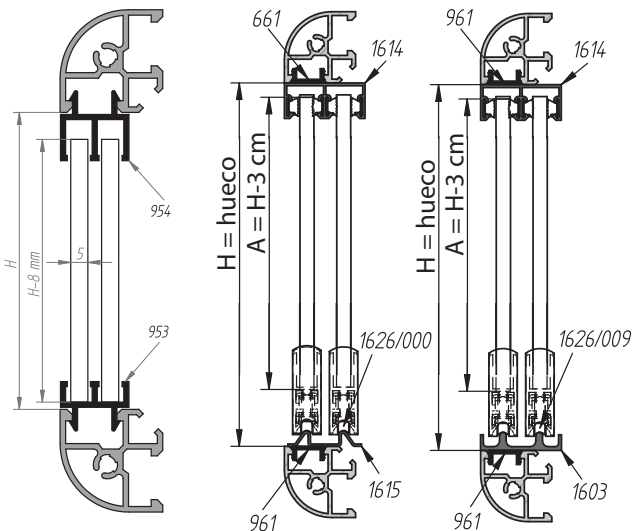

**CLICK**

VITRINAS Y MOSTRADORES - VETRINES  
SHOWCASES - VETRINE



**PERFIL QUADRANT**  
PERFIL QUADRANT  
QUADRANT PROFILE  
PROFILO QUADRANT  
868/1..

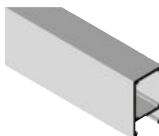

**1 SALIDA**  
1 RAINURÉS  
1 SLOT  
1 CANALE  
\*858/1..



**2 SALIDA**  
2 RAINURÉS  
2 SLOTS  
2 CANALI  
\*870/1..

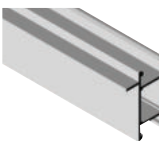

**2 SALIDA + 1 ALETA**  
2 RAINURÉS + 1 SUPPORT  
2 SLOTS + 1 SUPPORT  
2 CANALI + 1 APPOGGIO  
871/1..



**PERFIL BISAGRA**  
PROFIL CHARNIERE  
EDGE-HINGE PROFILE  
PROFILO CERNIERA  
\*869/1..



**2 BISAGRAS PARA 869**  
2 CHARNIERE  
2 HINGES  
2 CERNIERE  
\*949/001



**PERFIL TAPABOCAS**  
PROFIL COUVERTURE  
COVER PROFIL  
OROFILO COPRI-CANALE  
961/1..



**GRAPA ENSAMBLE**  
JOIN ASSEMBLAGE  
ASSEMBLY JOINT  
GRAPPA ASSEMBLAGGIO  
882/000

	PL, BR ALU, BR ALU, BR ALL, LUC	ORO DORÉ GOLD DOR, LUC	BR BR BR LUC BIANCO	BLANCO BLANC WHITE BIANCO	NEGRO NOIR BLACK NERO	PL, M ALU, M ALL, M ALL, NAT	COLOR COULEUR COLOR COLORE
	02	13	0B	0N	01	0P	
Al	5 m	30x30					€/m
		*o	o	o	o	o	
Al	5 m	35x20					€/m
		*o	o	o	o	o	
Al	5 m	45x20					€/m
		*o	o	o	o	o	
Al	5 m	45x20					€/m
		*o	o	o	o	o	
Al	5 m	30x20		∞ 949			€/m
		*o	o	o	o	o	
Al	plac	∞ 869					€/m
						*o	
Al	5 m	14x6					€/m
		*o	o	o	o	o	
Al	∞ 858-859-871-871-866						€/m
		o					

**CLICK**

VITRINAS Y MOSTRADORES - VETRINES  
SHOWCASES - VETRINE

	CR. BRILLO CHR. POLI BR. CHR. CR. ILLUC.	CR. MATE CHR. M M. CHR. CR. OPAC	CR. ORO CHR. DOR GOLD. C CR. ORO	BLANCO BLANC WHITE BIANCO	NEGRO NOIR BLACK NERO	COLOR COULEUR COLOR COLORE	BRUTO BRUT RAW GREZZO	
	32	31	33	0B	0N	0P	00	
	Al	∞ 868						€/u
	Zn	∞ 898						€/u
	Zn	∞ 898						€/u
	plas	∞ 868						€/u
	plas	∞ 868-874						€/u
	plas	∞ 893						€/u
	plas	∞ 893	∅50					€/u
	plas	∞ 893	∅50					€/u
	Fe							€/u
	Fe							€/u

ZINCADO  
PL. ZNK  
ZINK PL.  
ZINCATO

34

**CLICK**

VITRINAS Y MOSTRADORES - VETRINES  
SHOWCASES - VETRINE

PL. M ALL. M ALL. NAT	ORO DORÉ GOLD M DOR. OP	M M M OP	BLANCO BLANC WHITE BIANCO	NEGRO NOIR BLACK NERO	COLOR COULEUR COLOR COLORE	PLÁSTICO PLASTIQUE PLASTIC PLASTICA	
01	03	0B	0N	0P	09		
							plas 4 m 6-8 mm €/m
							plas 325 m €/m
							plas 4 m 5-6-8 mm €/m
							plas 4 m 5 mm €/m
							plas 4 m 5 mm €/m
							Al 2 / 3 m ∞ 1089-1090 €/u
							Al ∞ 867-1087-1100 €/u
							*1089/15...15 cm
							*1089/20...20 cm
							*1089/25...25 cm
							*1089/30...30 cm
							*1089/35...35 cm
							plas ∞ 1089-1900 €/u
							CR. BRILLO INOX BR CHR. POLI INOX POLI BR. CHR. P. S. S. CR. ILLUC. INOX ILLUC
							32 22
							inox s.s. 4-6 mm 40x22 12 kg/2u 961 €/u
							∞ 961
							∞ 961
							Cu 4-6 mm 25x20 2,5 kg/u 961 €/u
							∞ 961

APOYO Y/O BATIEN  
SUPPORT ET/OU BATTANT  
SUPPORT AND/OR DOOR STOP  
APPOGGIO E/O BATTENTE  
962/10N

FELPA  
BROSSER  
BRUSH  
FELPA  
1628/109

JUNQUILLO VIDRIO FIJO  
PROFILE VERRE FIXE  
FIXED GLASS PROFILE  
PROFILO VETRO FISSO  
956/10N

CORREDERA SUPERIOR  
COULISSE HAUTE  
SLIDING DOOR UPPER TRACK  
SCORREVOLE BINARIO ALTO  
954/10N

CORREDERA INFERIOR Y LATERAL  
COULISSE BASSE ET LATERALE  
SLIDING DOOR LOWER TRACK AND LATERAL  
SCORREVOLE BINARIO BASSO E LATERALI  
953/10N

CREMALLERA  
CRÉMAILLÈRE  
UPRIGHT  
CREMAGLIERA  
\*867/2..

CARTELAS  
SUPPORTS  
BRACKETS  
MENSOLE  
\*1089/15...15 cm  
\*1089/20...20 cm  
\*1089/25...25 cm  
\*1089/30...30 cm  
\*1089/35...35 cm

ALETA PLÁSTICO  
CAVALIER DOUBLE  
DOUBLE SADDLED  
CAVALIERE DOPPIO  
\*997/00N

BISAGRA CAZOLETA  
CHARNIÈRE PIVOTEMENT  
PIVOTING HINGE  
CERNIERA CARDINE  
1522/0.. IZQ.  
gauche/left/sinistra  
1523/0.. DER.  
droite/right/destra

BISAGRA PARED-VIDRIO  
CHARNIÈRE MUR-VERRE  
HINGE WALL-GLASS  
CERNIERA PARETE-VETRO  
1963/032

# KARR 1

5/6 mm

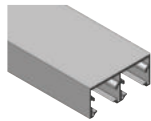

**SUPERIOR DOBLE FELPA**  
COULISSE HAUTE DOBLE  
UPPER DOUBLE TRACK  
GUIDA SUPERIOR DOPPIA  
1614/1..



**SUPERIOR FELPA**  
COULISSE HAUTE DOBLE  
UPPER DOUBLE TRACK  
GUIDA SUPERIOR DOPPIA  
\*1601/1..

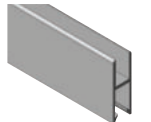

**CASACA VIDRIO**  
PROFIL VERRE  
PROFILE GLASS  
PROFILO VETRO  
1602/1..



**CARRIL INFERIOR DOBLE**  
RAIL DOBLE INFERIEUR  
LOWER DOUBLE RAIL  
BINARIO DOPPIO INF.  
1603/1..



**CARRIL INFERIOR DOBLE**  
RAIL DOBLE INFERI  
LOWER DOUBLE RAIL  
BINARIO DOPPIO INF.  
1615/128



**PALA TIRADOR**  
EMBOUT MET.+POIGNÉE  
METALIC END-CAP+PULL  
COPRITESTA MET.+MANIG.  
1624/0..



**COJINETE HIERRO**  
GALET ACIER  
METALLIC ROLLER  
PATTINO METAL. SCORREV.  
1626/000



**PALA METÁLICA**  
EMBOUT METAL  
METALLIC END-CAP  
COPRITESTA METALLICO  
1627/0..



**PALA PLÁSTICO NEGRO**  
EMBOUT PLASTIQUE NOIR  
BLACK PLASTIC END-CAP  
COPRITESTA PLAST.NERO  
1627/009



**FELPA**  
BROSSER  
BRUSH  
FELPA  
1628/109



**GOMA CASACA**  
CAOUTCHOUC VERRE  
GLASS RUBBER  
GOMMA VETRO  
1644/00N

## UÑERO



**UÑERO ADHESIVO**  
POIGNÉE ADHESIVE  
ADHESIVE DOOR PULL  
MANIGLIA ADESIVA  
1625/009

	PL-M ALU.M ALL.NAT	ORO M DORÉ M DOR.OP	BLANCO GOLD M BIANCO	NEGRO NOIR NERO	COLOR COULEUR COLORE	BRUTO BRUT GREZZO
	01	03	0B	0N	0P	00
Al $\frac{5}{6}$ m	$\infty$ 1628					€/m
	o		o	o	o	
Al $\frac{5}{6}$ m	$\infty$ 1628					€/m
	*o		*o	*o	*o	
Al $\frac{5}{6}$ m	$\frac{5-6}{6}$ mm					€/m
	o		o	o	o	
Al $\frac{5}{6}$ m	$\infty$ 1626/009					€/m
	o		o	o	o	
inox s.s. $\frac{5}{6}$ m	$\infty$ 1626/000					€/m
						o
Zn						€/u
	o	o	o	o	o	
Fe CuZn 15 kg/u	$\infty$ 1615					€/u
						o
Fe						€/u
	o	*o	o	o	o	
plac						€/u
						o
plac $\frac{3}{4}$ 325 m						€/m
						o
plac $\frac{5}{6}$ mm	$\frac{3}{4}$ 125 m					€/m
						o
plac transp.						€/u
						o

# CERRADURA VITRINAS

SERRURES POUR VETRINES  
GLASS SHOWCASES LOCKS  
SERRATURE PER VETRINE

CR.BRILLO C.R.FOJ BR.CFR CR.LUC.	CR.MATE C.R.M M.CFR CR.OPAC	CR.ORO C.R.DOR GOLD.C CR.ORO
32	31	33



**CERRADURA LÁPIZ**  
SERRURE VERRE AVEC TRAU  
LOCK FOR DRILLED GLASS  
SERRATURA VETRO FORATO  
1500/032 MISMA LLAVE  
même comb. keyed alike stesso chiave  
1500/132 DISTINTA LLAVE  
comb. variée, differ key, chiave distinta

Zn $\frac{5}{6}$ mm	$\frac{1}{2}$ 16	€/u
$\infty$ KARR 1 - KARR 2		
		o
		o



**CERRADURA DE SERRETA**  
SERRURE CRÉMAILLÈRE AMOVIBLE  
RATCHET LOCK  
SERRATURA CREMAGLIERA  
1502/032 DISTINTA LLAVE  
comb. variée, differ key, chiave distinta  
1501/032 MISMA LLAVE  
même comb. keyed alike stesso chiave

Zn $\frac{5}{6}$ 4-8 mm	$\frac{1}{2}$	€/u
		o
		o



**CERRADURA PULSADOR**  
SERRURE PORTES COULISSANTES  
SLIDING DOOR LOCK  
SERRATURA PER SCORREVOLI  
1497/0.. MISMA LLAVE  
même comb. keyed alike stesso chiave

Zn $\infty$ KARR system		€/u
		o

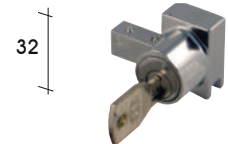

**CERRADURA PALA**  
SERRURE PORTES COULISSANTES  
SLIDING DOOR LOCK  
SERRATURA PER SCORREVOLI  
1504/0.. MISMA LLAVE  
même comb. keyed alike stesso chiave

Zn $\infty$ KARR 1		€/u
		o

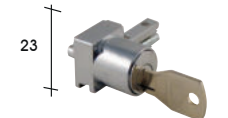

**CERRADURA PALA**  
SERRURE PORTES COULISSANTES  
SLIDING DOOR LOCK  
SERRATURA PER SCORREVOLI  
1528/0.. MISMA LLAVE  
même comb. keyed alike stesso chiave

Zn $\infty$ KARR 2		€/u
		o



**CERRADURA VITRINA**  
SERRURE AVEC TRAU  
DRILLED GLASS LOCK  
SERRATURA VETRO FORATO  
1505/032 MISMA LLAVE  
même comb. keyed alike stesso chiave

Zn $\frac{5}{6}$ 5-6 mm	$\frac{1}{2}$ 26	€/u
		o



**CERRADURA PUERTA BATIENTE**  
SERRURE PORTE BATTANTE  
SWINGING DOOR LOCK  
SERRATURA PORTA BATTENTE  
1495/032 MISMA LLAVE  
même comb. keyed alike stesso chiave

Zn $\frac{5}{6}$ 4-6 mm	$\frac{1}{2}$	€/u
		o



**CONTRACERRADURA VIDRIO SIN MUESCA**  
GAÛCHE VERRE SANS ENCOCHE  
GLASS STRIKE WITHOUT CUT-OUT  
CONTROSERRATURA VETRO SENZA TACCA  
1491/032

Zn $\frac{5}{6}$ 4-6 mm	$\frac{1}{2}$	€/u
$\infty$ 1495		
		o



**CERRADURA 2 PUERTA BATIENES**  
SERRURE 2 PORTES BATTANTE  
SWINGING 2 DOORS LOCK  
SERRATURA 2 PORTE BATTENTI  
1496/032 MISMA LLAVE  
même comb. keyed alike stesso chiave

Zn $\frac{5}{6}$ 4-6 mm	$\frac{1}{2}$	€/u
		o

**CLICK STOCK SERVICE**  
VITRINAS Y MOSTRADORES - VETRINES  
SHOWCASES - VETRINE

BLANCO BLANC WHITE BIANCO	PL. M ALU. M ALL. M ALL. NAT	NEGRO NOIR BLACK NERO	COLOR COULEUR COLOR COLORE
0B	01	0N	0P

**CLICK STOCK SERVICE**  
VITRINAS Y MOSTRADORES - VETRINES  
SHOWCASES - VETRINE

BLANCO BLANC WHITE BIANCO	NEGRO NOIR BLACK NERO	PL. M ALU. M ALL. M ALL. NAT	COLOR COULEUR COLOR COLORE
0B	0N	01	0P

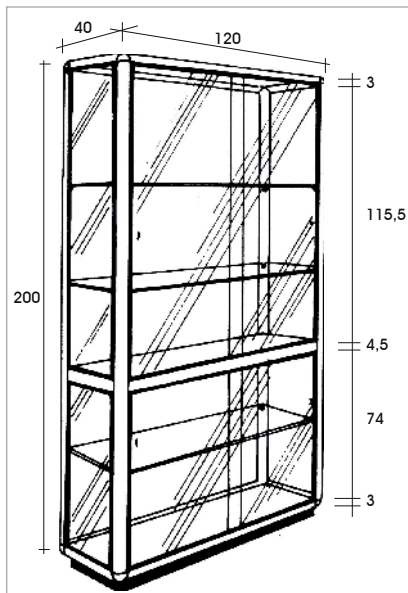

**VITRINA 2 CUERPOS**  
MEDIDAS: 200 x 120 x 40cm  
CORREDERAS PLÁSTICO.  
EL PRECIO INCLUYE SÓLO LA ESTRUCTURA DE ALUMINIO, JUNQUILLOS Y 2 CERRADURAS SERRETA. NO SE SUMINISTRAN CRISTALES Y MADERAS.

*VETRINE 2 CORPS.*  
MESURES: 200 X 120 X 40 CM  
COULISSANT EN PLASTIQUE.  
LE PRIX COMPREND LA STRUCTURE EN ALUMINIUM, LES PROFILS EN PLASTIQUE ET 2 SERRURES AVEC CREMAILLEIRE. NOUS NE FOURNISSONS PAS DE VERRE ET DE BOIS.

*SHOWCASE 2 BODIES.*  
SIZES: 200 X 120 X 40 CM.  
PLASTIC SLIDING DOOR  
THE PRICE INCLUDES THE ALUMINIUM STRUCTURE, THE PLASTIC PROFILES AND 2 RATCHET LOCKS.  
WE DONT SUPPLY GLASS AND WOOD.

*VETRINA 2 CORPI.*  
MISURE: 200 X 120 X 40 CM  
SCORREVOLI IN PLASTICA.  
IL PREZZO COMPRENDE LA STRUTTURA DI ALLUMINIO, I PROFILI DI PLASTICA E 2 SERRATURE CREMAGLIERA. NON FORNIAMO VETRI E LEGNO.

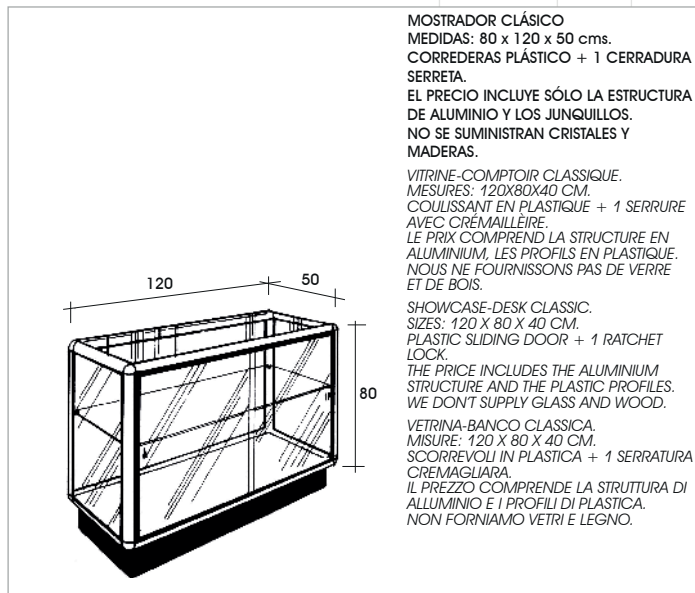

**MOSTRADOR CLÁSICO**  
MEDIDAS: 80 x 120 x 50 cms.  
CORREDERAS PLÁSTICO + 1 CERRADURA SERRETA.  
EL PRECIO INCLUYE SÓLO LA ESTRUCTURA DE ALUMINIO Y LOS JUNQUILLOS. NO SE SUMINISTRAN CRISTALES Y MADERAS.

*VITRINE-COMPTOIR CLASSIQUE.*  
MESURES: 120X80X40 CM.  
COULISSANT EN PLASTIQUE + 1 SERRURE AVEC CREMAILLEIRE.  
LE PRIX COMPREND LA STRUCTURE EN ALUMINIUM, LES PROFILS EN PLASTIQUE. NOUS NE FOURNISSONS PAS DE VERRE ET DE BOIS.

*SHOWCASE-DESK CLASSIC.*  
SIZES: 120 X 80 X 40 CM.  
PLASTIC SLIDING DOOR + 1 RATCHET LOCK.  
THE PRICE INCLUDES THE ALUMINIUM STRUCTURE AND THE PLASTIC PROFILES. WE DONT SUPPLY GLASS AND WOOD.

*VETRINA-BANCO CLASSICA.*  
MISURE: 120 X 80 X 40 CM.  
SCORREVOLI IN PLASTICA + 1 SERRATURA CREMAGLIARA.  
IL PREZZO COMPRENDE LA STRUTTURA DI ALLUMINIO E I PROFILI DI PLASTICA. NON FORNIAMO VETRI E LEGNO.

VT125/0..



MC123/0..

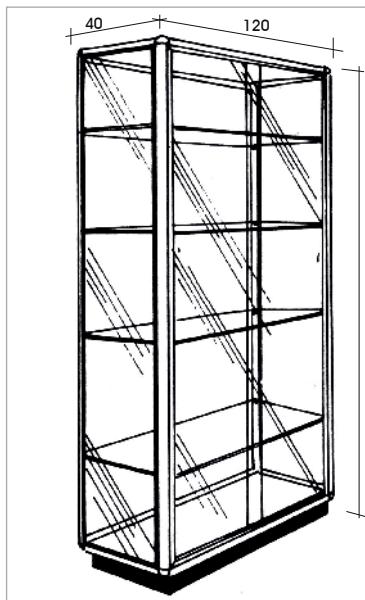

**VITRINA 1 CUERPO**  
MEDIDAS: 200 x 120 x 40cm  
CORREDERAS DE ALUMINIO.  
EL PRECIO INCLUYE SÓLO LA ESTRUCTURA DE ALUMINIO, JUNQUILLOS Y 1 CERRADURA SERRETA. NO SE SUMINISTRAN CRISTALES Y MADERAS.

*VETRINE 1 CORP.*  
MESURES: 200 X 120 X 40 CM  
COULISSANT EN ALUMINIUM.  
LE PRIX COMPREND LA STRUCTURE EN ALUMINIUM, LES PROFILS EN PLASTIQUE ET 1 SERRURE AVEC CREMAILLEIRE. NOUS NE FOURNISSONS PAS DE VERRE ET DE BOIS.

*SHOWCASE 1 BODY.*  
SIZES: 200 X 120 X 40 CM.  
ALUMINIUM SLIDING DOOR  
THE PRICE INCLUDES THE ALUMINIUM STRUCTURE, THE PLASTIC PROFILES AND 1 RATCHET LOCK.  
WE DONT SUPPLY GLASS AND WOOD.

*VETRINA 1 CORPO.*  
MISURE: 200 X 120 X 40 CM  
SCORREVOLI IN ALLUMINIO.  
IL PREZZO COMPRENDE LA STRUTTURA DI ALLUMINIO, I PROFILI DI PLASTICA E 1 SERRATURA CREMAGLIERA. NON FORNIAMO VETRI E LEGNO.

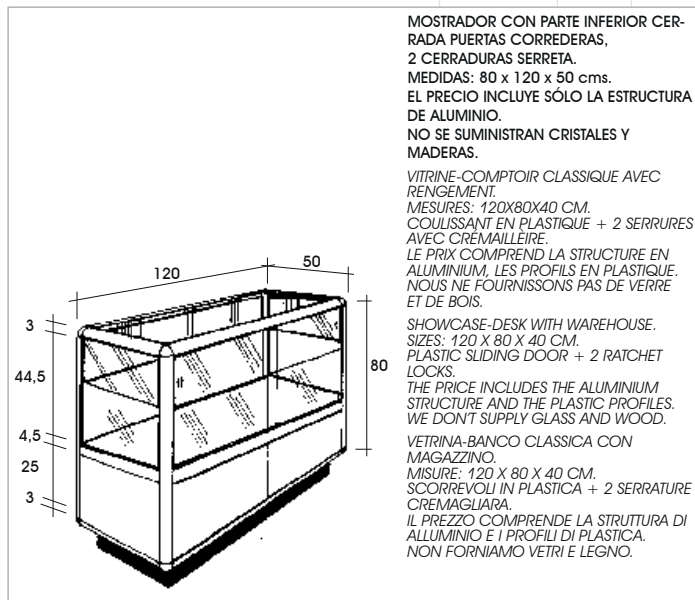

**MOSTRADOR CON PARTE INFERIOR CERRADA PUERTAS CORREDERAS, 2 CERRADURAS SERRETA.**  
MEDIDAS: 80 x 120 x 50 cms.  
EL PRECIO INCLUYE SÓLO LA ESTRUCTURA DE ALUMINIO. NO SE SUMINISTRAN CRISTALES Y MADERAS.

*VITRINE-COMPTOIR CLASSIQUE AVEC RENGELEMENT.*  
MESURES: 120X80X40 CM.  
COULISSANT EN PLASTIQUE + 2 SERRURES AVEC CREMAILLEIRE.  
LE PRIX COMPREND LA STRUCTURE EN ALUMINIUM, LES PROFILS EN PLASTIQUE. NOUS NE FOURNISSONS PAS DE VERRE ET DE BOIS.

*SHOWCASE-DESK WITH WAREHOUSE.*  
SIZES: 120 X 80 X 40 CM.  
PLASTIC SLIDING DOOR + 2 RATCHET LOCKS.  
THE PRICE INCLUDES THE ALUMINIUM STRUCTURE AND THE PLASTIC PROFILES. WE DONT SUPPLY GLASS AND WOOD.

*VETRINA-BANCO CLASSICA CON MAGAZZINO.*  
MISURE: 120 X 80 X 40 CM.  
SCORREVOLI IN PLASTICA + 2 SERRATURE CREMAGLIARA.  
IL PREZZO COMPRENDE LA STRUTTURA DI ALLUMINIO E I PROFILI DI PLASTICA. NON FORNIAMO VETRI E LEGNO.

VT200/0..



MA127/C..

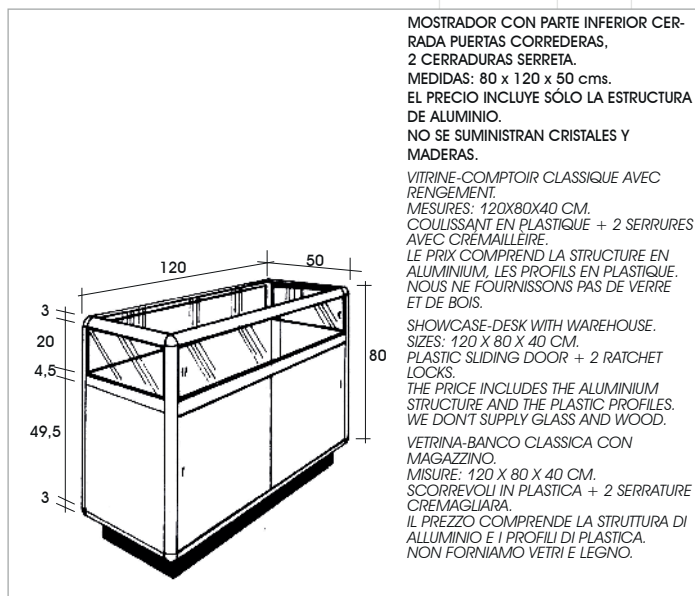

**MOSTRADOR CON PARTE INFERIOR CERRADA PUERTAS CORREDERAS, 2 CERRADURAS SERRETA.**  
MEDIDAS: 80 x 120 x 50 cms.  
EL PRECIO INCLUYE SÓLO LA ESTRUCTURA DE ALUMINIO. NO SE SUMINISTRAN CRISTALES Y MADERAS.

*VITRINE-COMPTOIR CLASSIQUE AVEC RENGELEMENT.*  
MESURES: 120X80X40 CM.  
COULISSANT EN PLASTIQUE + 2 SERRURES AVEC CREMAILLEIRE.  
LE PRIX COMPREND LA STRUCTURE EN ALUMINIUM, LES PROFILS EN PLASTIQUE. NOUS NE FOURNISSONS PAS DE VERRE ET DE BOIS.

*SHOWCASE-DESK WITH WAREHOUSE.*  
SIZES: 120 X 80 X 40 CM.  
PLASTIC SLIDING DOOR + 2 RATCHET LOCKS.  
THE PRICE INCLUDES THE ALUMINIUM STRUCTURE AND THE PLASTIC PROFILES. WE DONT SUPPLY GLASS AND WOOD.

*VETRINA-BANCO CLASSICA CON MAGAZZINO.*  
MISURE: 120 X 80 X 40 CM.  
SCORREVOLI IN PLASTICA + 2 SERRATURE CREMAGLIARA.  
IL PREZZO COMPRENDE LA STRUTTURA DI ALLUMINIO E I PROFILI DI PLASTICA. NON FORNIAMO VETRI E LEGNO.

MA127/0..



# instal.



Sistemas Kadí  
y Kadí Elektric

Sistema lamas y  
multilamas

Sistemas Star, JS,  
Óptica

**TARIFA 63**

01/07/2023

## INSTAL - ÍNDEX

### SISTEMA KADÍ

<b>1- KADÍ ELEKTRIC CREMALLERA ALU</b>	<b>03</b>
Guía-cremalleras electrificadas con sistema de iluminación integrado a los estantes	
<b>2- CREMALLERAS</b>	<b>21</b>
Guía-cremalleras y accesorios para estantes	
<b>3- COLUMNAS</b>	<b>37</b>
Perfiles para estanterías sin panelado	
<b>4- KADÍ ELEKTRIC PHARMA</b>	<b>39</b>
Sistema autoportante para panelar con sistema de iluminación integrado a los montantes y a los estantes	
<b>5- PHARMA</b>	<b>57</b>
Sistema autoportante y accesorios para estantes para panelar	
<b>6- SEPARADORES Y PORTAPRECIOS</b>	<b>64</b>
<b>7- KADÍ ELEKTRIC PRIMO</b>	<b>65</b>
Sistema autoportante con sistema de iluminación integrado a los montantes y a los estantes - Tubo 25x25 mm	
<b>8- PRIMO</b>	<b>81</b>
Sistema autoportante y accesorios para estantes - Tubo 25x25 mm	



## KADÍ ELEKTRIC - CREMALLERA ALU





## KADÍ ELEKTRIC - CREMALLERA ALU



ESCANEA ESTE QR  
PARA VER TODAS  
LAS IMÁGENES DE LA  
CREMALLERA ALU



## KADÍ CREMALLERA ELEKTRIC

Ejemplos orientativos  
de distintas posibilidades,  
distribuciones y  
aplicaciones

# KADÍ ELEKTRIC - CREMALLERA ALU

## EXPLOSIONADO GENERAL

### MONTAJE EN SERIE

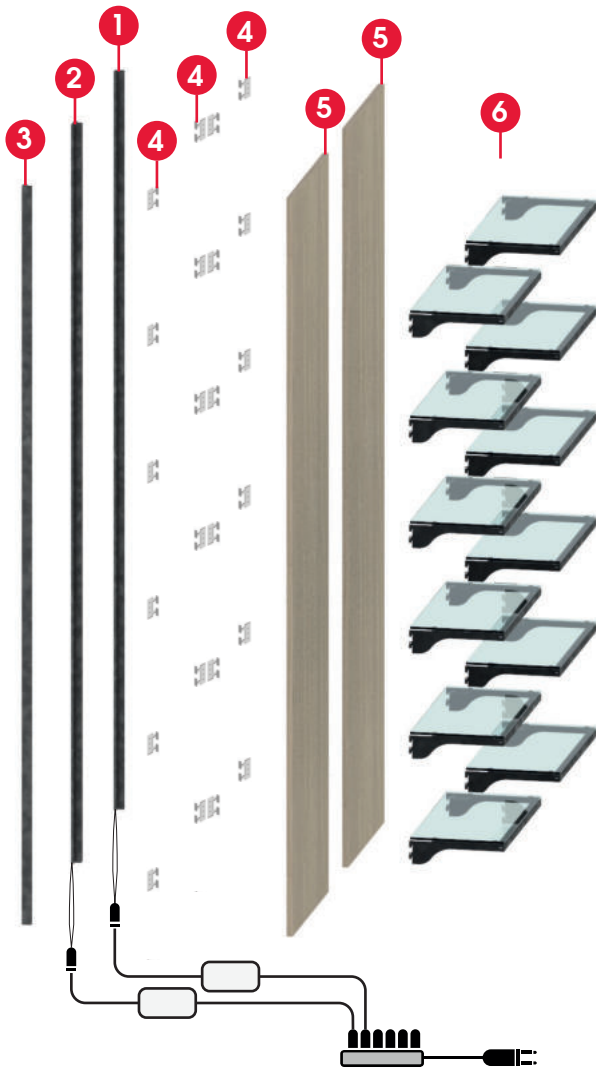

Colocar las cremalleras ELECTRIFICADAS EN LADO DERECHO de cada panel

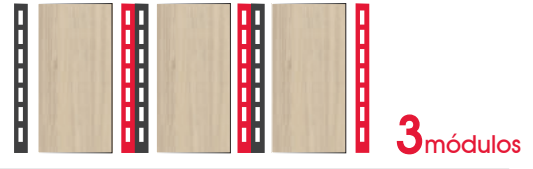

- REF: 4872 (CREMALLERA 1CANAL)  
+ 4871 (CARRIL ELEKTRIC) Cremalleras electrificadas exteriores - 1 canal
- REF: 4870 (CREMALLERA 2CANALES)  
+ 4871 (CARRIL ELEKTRIC) Cremalleras electrificadas interiores - 2 canales
- REF: 4872 (CREMALLERA 1CANAL) Cremalleras sin carril eléctrico exteriores - 1 canal

- 1** Cremallera electrificada - 1 canal  
REF: 4872 +4871
- 2** Cremallera electrificada - 2 canales  
REF: 4870 +4871
- 3** Cremallera sin carril eléctrico - 1 canal  
REF: 4872

- 4** Grapas para colgar paneles  
2 posibles modelos:  
- Clásicas  
- Modelo rediseñado con aplicación frontal  
 REF: 4616  
 REF: 4607

- 5** Paneles (NO INCLUIDOS)

- 6** Accesorios  
Personalizable:  
- Estantes  
- Barras  
- Perroquets

# KADÍ ELEKTRIC - CREMALLERA ALU

## MONTAJE ELÉCTRICO

HASTA X6 PANELES ▶ X1 

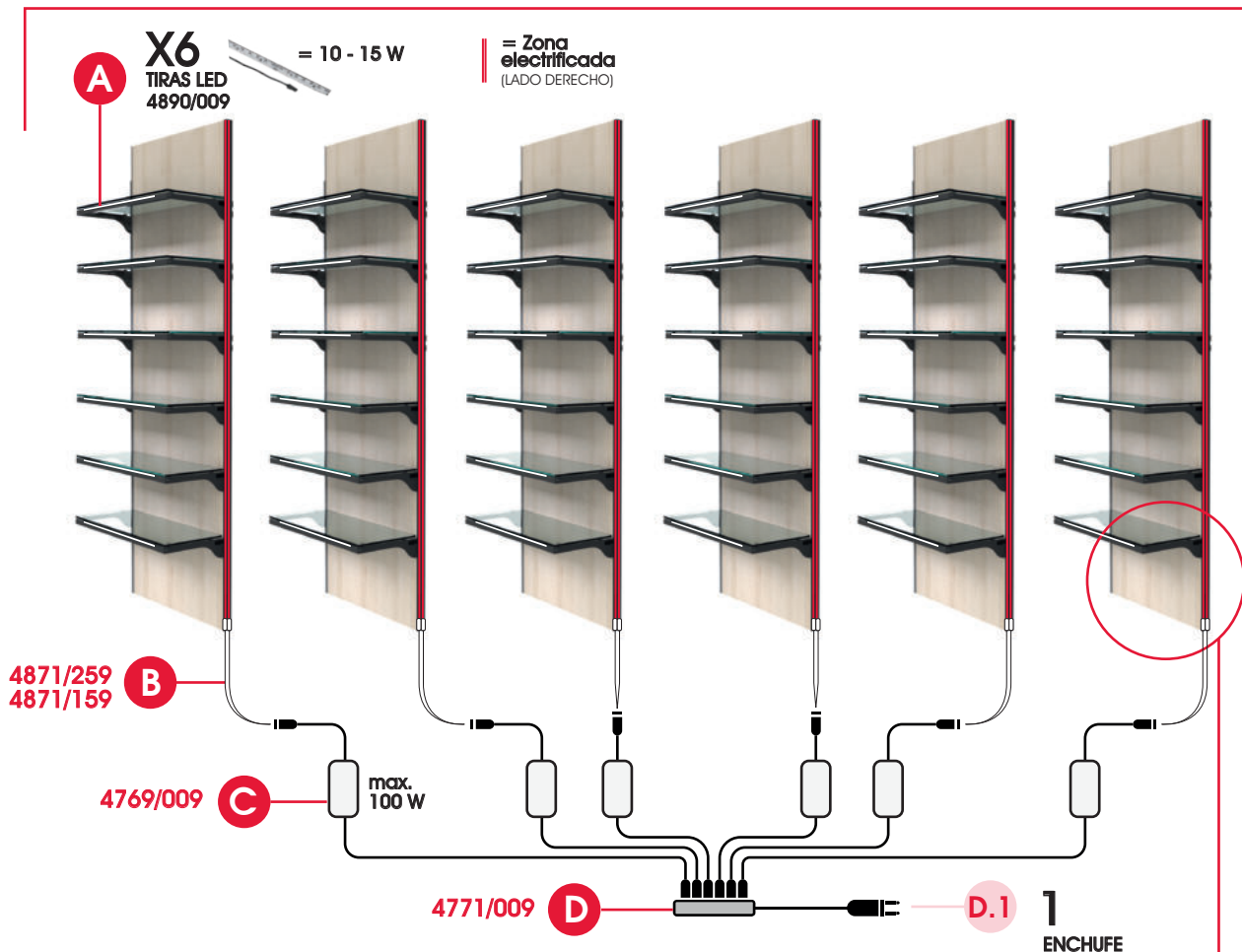

- A** Tiras LED  
(6 ud. por transformador)
- B** Cable con mini conector  
**LONGITUD DEL CABLE - 1M**
- C** Transformador  
(Cada panel debe llevar su transformador)
- D** Regleta de distribución
- D.1** Enchufe

- ES** • El carril electrificado lleva soldado el cable de conexión en la parte inferior. En el caso de prescindir de este conector Gesis, prestar atención a la polaridad de los cables para el correcto funcionamiento de la nueva conexión.
- FR** • La voie électrifiée porte le câble de connexion au conducteur en bas. En cas de suppression avec ce connecteur Gesis, faites attention à la polarité des câbles pour le bon fonctionnement de la nouvelle connexion.
- EN** • The electrified track carries the connection cable to the driver at the bottom. In the case of dispensing with this connector Gesis, pay attention to the polarity of the cables for the correct functioning of the new connection.
- IT** • Il binario elettrificato ha il cavo di connessione al driver saldato nella parte inferiore. Nel caso di prescindere del connettore Gesis, controllare la polarità dei cavi per assicurare il corretto funzionamento della nuova connessione.

**Cualquier manipulación invalida la garantía del fabricante** 

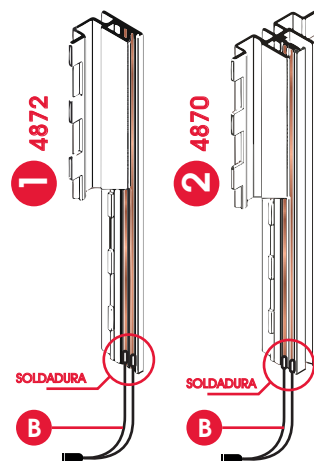

# KADÍ ELEKTRIC - CREMALLERA ALU

## MONTAJE DE LOS PLAFONES A LAS CREMALLERAS

### SISTEMA MEDIANTE ENGANCHES

### ENGANCHES 4616/034

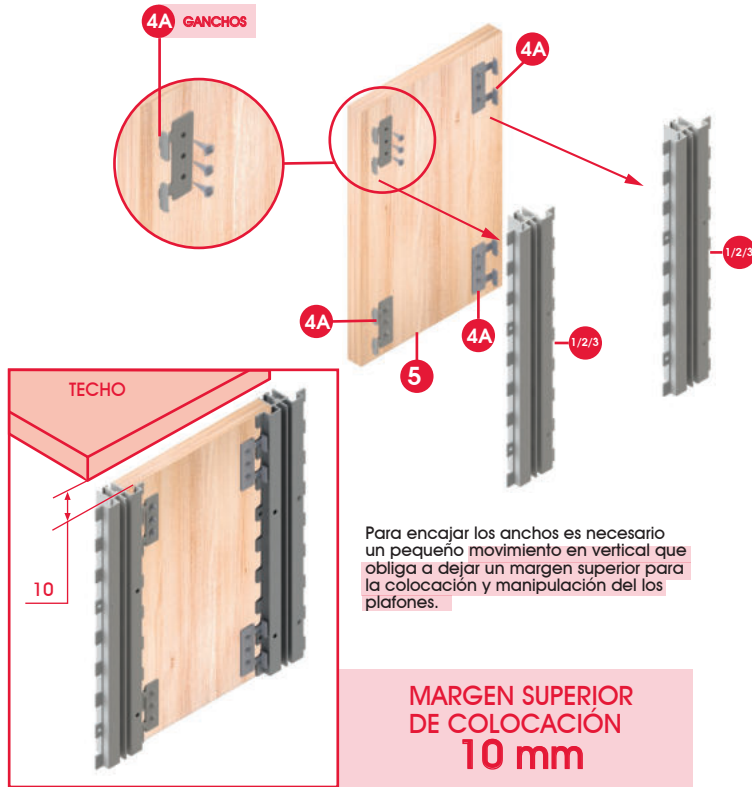

- 1 Cremallera electrificada 1 carril
- 2 Cremallera 2 carriles
- 3 Cremallera sin electrificar 1 carril
- 4 Ganchos / Grapas
- 5 Panel

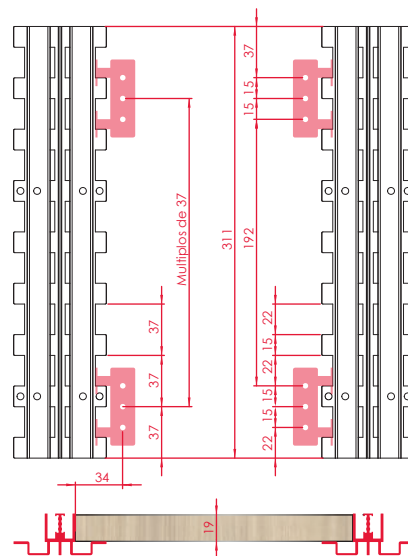

### SISTEMA MEDIANTE CLIPAJES

### NOVEDAD

### CLIPAJES 4607/028

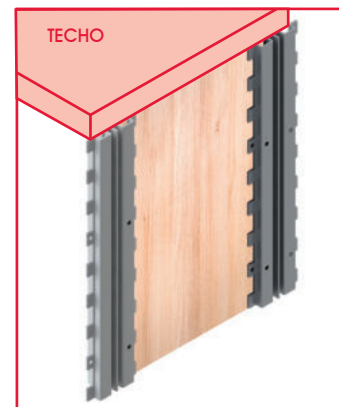
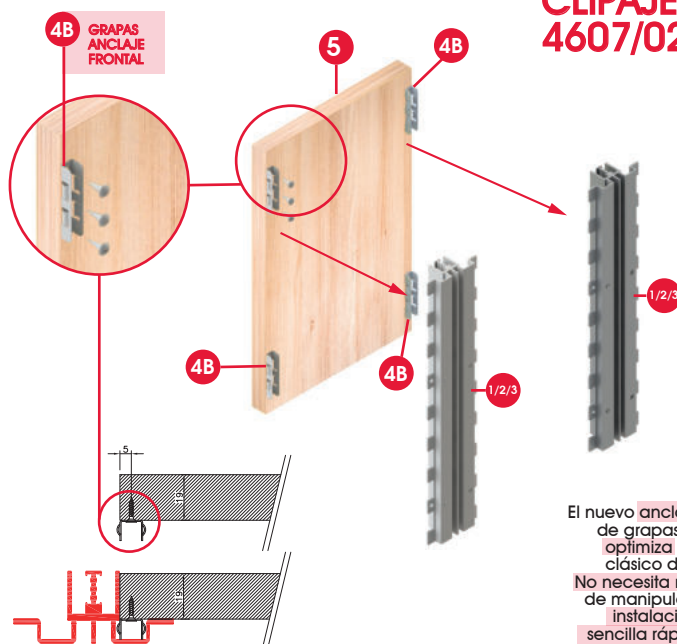

COLOCACIÓN FRONTAL  
MARGEN 0 mm

# KADÍ ELEKTRIC - CREMALLERA ALU

## CREMALLERAS ELECTRIFICADAS

**1**

CREMALLERA ELECTRIFICADA 1 CANAL

REF. 4872

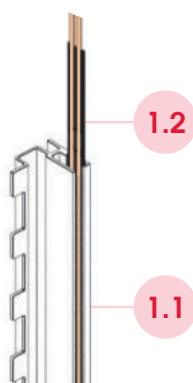

1.1 Cremallera

1.2 Carril eléctrico

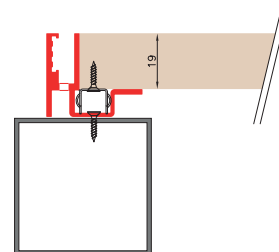
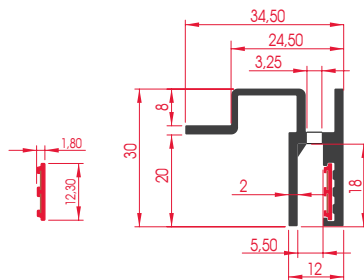

**2**

CREMALLERA ELECTRIFICADA 2 CANALES

REF. 4870

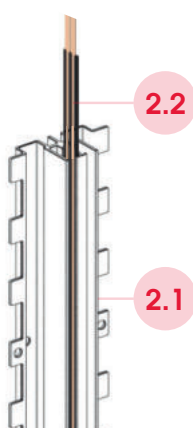

2.1 Cremallera

2.2 Carril eléctrico

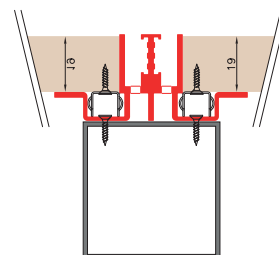
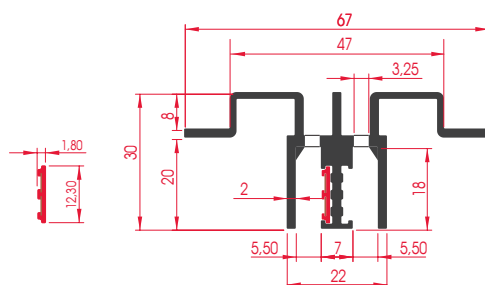

**3**

NOVA CREMALLERA ELECTRIFICADA 1 CANAL

REF. 4874

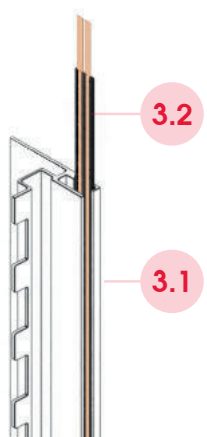

1.1 Cremallera

1.2 Carril eléctrico

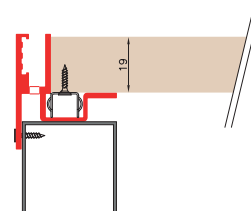
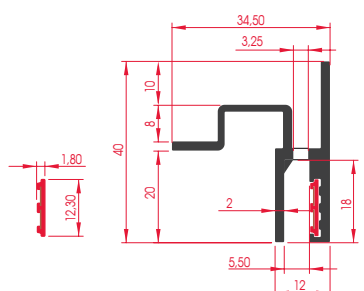

# KADÍ ELEKTRIC - CREMALLERA ALU

## ACCESORIOS CREMALLERA ALU

-  Vidrio
-  Madera

### ESTANTES

#### CARGA LIGERA



3890/1..



3891/1..



#### CARGA MEDIA



3894/1..



\* Inclinación 3-4° aprox.

#### CARGA ALTA



3895/1..

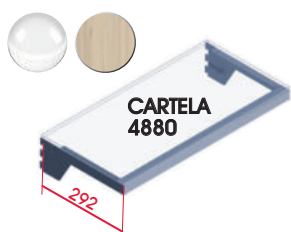

3896/1..



#### CARGA MEDIA



5370/00B



### BARRAS

#### CARGA LIGERA



4901/1..

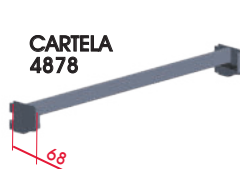

4910/1..

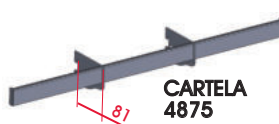

#### CARGA MEDIA



3897/1..



#### CARGA MEDIA



3898/1..



### PERROQUET

#### CARGA LIGERA



4725/1..

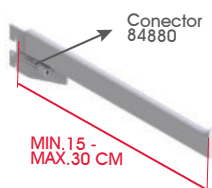

# KADÍ ELEKTRIC - CREMALLERA ALU

## TABLA DE PESOS

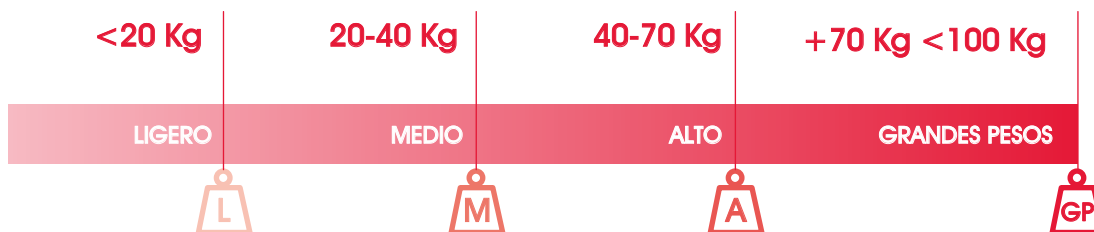

## COMPORTAMIENTO DE CARGA

● Puntos conflictivos de carga

\* La inclinación puede variar dependiendo del peso y la flexibilidad del aluminio.

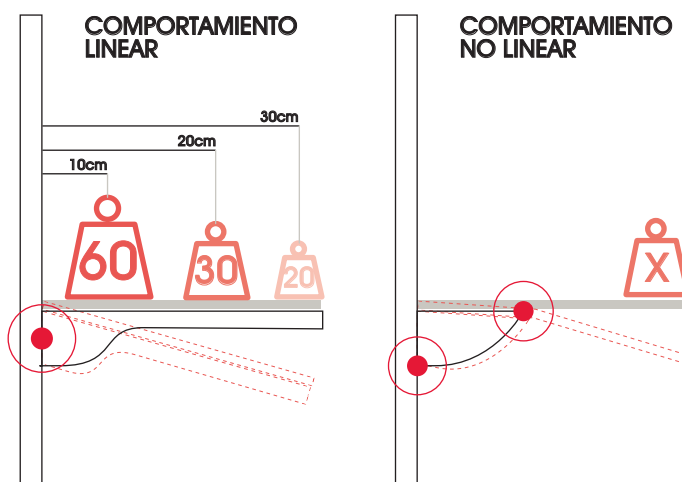

AL ENCAJAR SE ENCIENDE

Con el sistema PLUG & PLAY el montaje de los módulos de carga resulta fácil, rápido y muy práctico, ya que solo encajando las cartelas a las cremalleras, el circuito eléctrico queda totalmente conectado y el LED encendido.

- FÁCIL
- RÁPIDO
- PRÁCTICO

## PLUG & PLAY



# KADÍ ELEKTRIC - CREMALLERA ALU

## PERROQUET



CARGA LIGERA

4725/1..

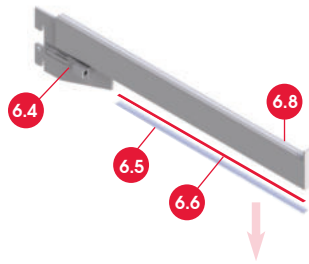

- 6.1 VIDRIO Base de los estantes
- 6.2 MADERA Base de los estantes
- 6.3 Cartelas
- 6.4 Conector
- 6.5 Difusor
- 6.6 Tira LED
- 6.7 Conductor adhesivo
- 6.8 Barra

## BARRAS



CARGA LIGERA

4901/1..

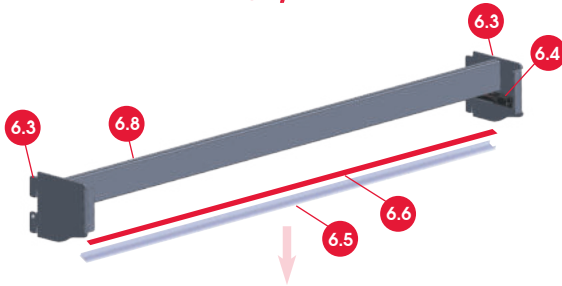

4910/1..

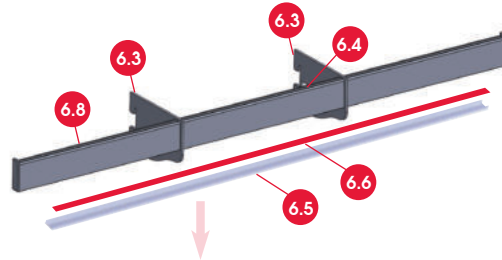

CARGA MEDIA

3898/1..

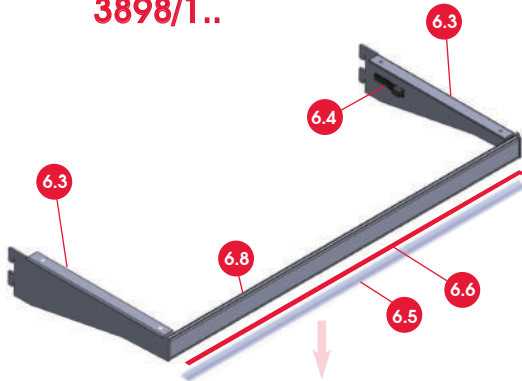

3897/1..

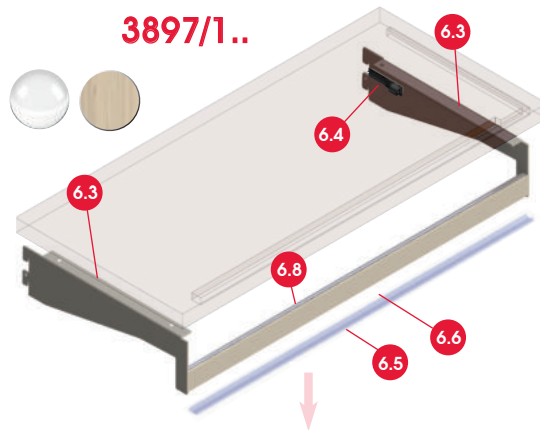



# KADÍ ELEKTRIC - CREMALLERA ALU



## ESTANTES



CARGA LIGERA

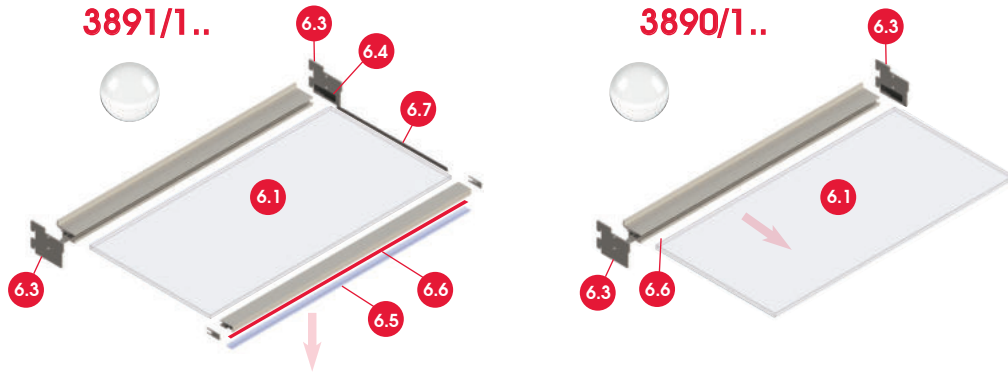

CARGA MEDIA

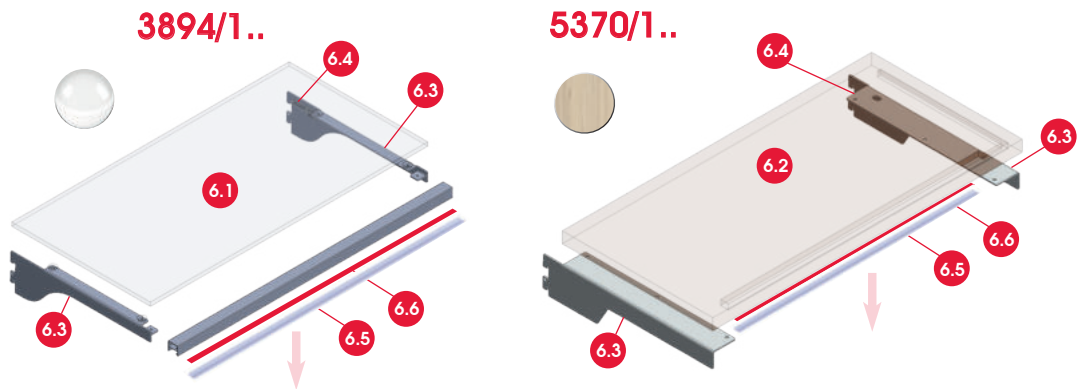

CARGA ALTA

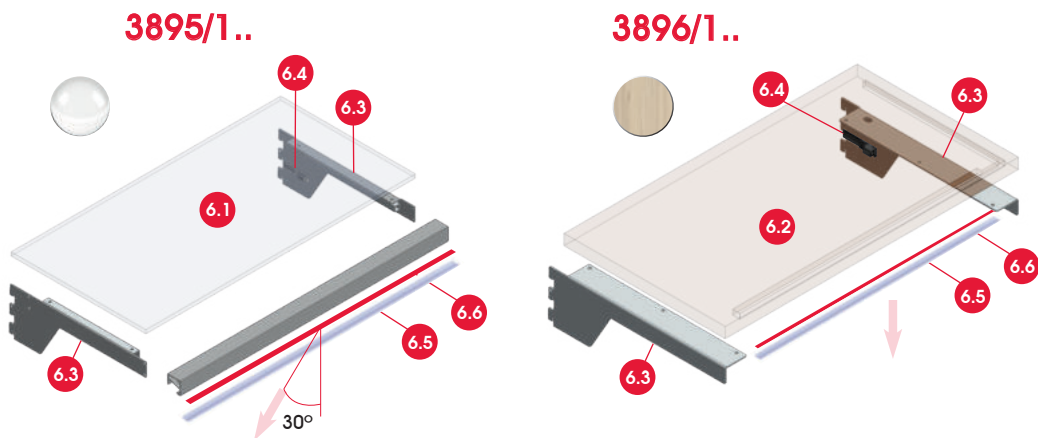



# KADÍ ELEKTRIC - CREMALLERA ALU

## CREMALLERAS

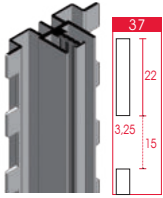

GUÍA ELECTRIFICABLE  
PANELABLE - 2 CANALES  
CRÉMAILLÈRE ÉLECTRIFIABLE  
AVEC DOUBLE PERFORATION  
ELECTRIFIABLE DOUBLE SLOT  
RACK  
CREMAGLIERA ELETRIFICABILE  
CON FORATURA DOPPIA  
**4870/1... 5M**  
**4870/57... 5.7M**

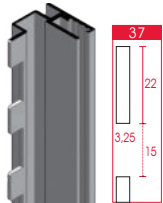
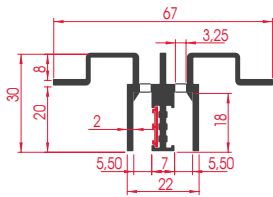

GUÍA ELECTRIFICABLE  
PANELABLE - 1 CANAL  
CRÉMAILLÈRE ÉLECTRIFIABLE  
AVEC SINGLE PERFORATION  
ELECTRIFIABLE SINGLE SLOT  
RACK  
CREMAGLIERA ELETRIFICABILE  
CON FORATURA SEMPLICE  
**4872/1... 5M**  
**4872/57... 5.7M**

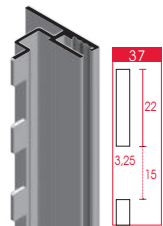
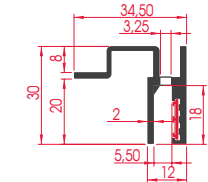

GUÍA ELECTRIFICABLE  
PANELABLE - 1 CANAL - FINAL  
CRÉMAILLÈRE ÉLECTRIFIABLE  
FINAL AVEC SINGLE  
PERFORATION  
FINAL ELECTRIFIABLE SINGLE  
SLOT RACK  
CREMAGLIERA ELETRIFICABILE  
FINALE CON FORATURA  
SEMPLICE  
**4874/1..**

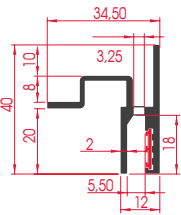

**! NUEVO**

PL. M	BLANCO	NEGRO	COLOR
ALU. M	BLANC	NOIR	COULEUR
ALL. NAT	WHITE	BLACK	COLOR
	BIANCO	NERO	COLORE
01	0B	0N	0P

Al	5 m - 5,7 m	67x30	€/m
----	-------------	-------	-----

<input type="radio"/>	<input type="radio"/>	<input type="radio"/>	<input type="radio"/>
<input type="radio"/>	<input type="radio"/>	<input type="radio"/>	<input type="radio"/>

Al	5 m - 5,7 m	35x30	€/m
----	-------------	-------	-----

<input type="radio"/>	<input type="radio"/>	<input type="radio"/>	<input type="radio"/>
<input type="radio"/>	<input type="radio"/>	<input type="radio"/>	<input type="radio"/>

Al	5 m	35x40	€/m
----	-----	-------	-----

<input type="radio"/>	<input type="radio"/>	<input type="radio"/>	<input type="radio"/>
-----------------------	-----------------------	-----------------------	-----------------------

# KADÍ ELEKTRIC - CREMALLERA ALU

## CARRIL ELECTRIFICADO



CARRIL ELECTRIFICADO + CABLE  
CONEXIÓN A DRIVER (1M)  
VOIE ÉLECTRIFIÉE + CÂBLE DE  
CONNEXION A DRIVER (1M)  
ELECTRIFIED TRACK + CONNECTION  
WIRE TO DRIVER (1M)  
BINARIO ELETRIFICATO + CAVO  
CONNESSIONE DRIVER (1M)  
**4871/259 2.5M**  
**4871/159 1.5M**

Fe	4870-4872 - 4874	€/u
----	------------------	-----

CARRIL ELECTRIFICADO SIN CABLE  
CONEXIÓN A DRIVER (1M)  
**4871/109 1M**

Max. 6A	25mm	€/m
---------	------	-----

CABLE CON MINI-CONECTORES  
230V  
CABLE + MINI PLUG - 230V  
CABLE + MINI PLUG - 230V  
CAVO + MINI PLUG - 230V  
**6015/00B**

Plc	3 m	230 V	€/u
		2,5 A	

**6**

Cable para soldar al carril 4871/109.  
CONEXIÓN CON DRIVER 6010

## GRAPAS



ENGANCHE PARA COLGAR PANELES -  
19MM GROSOR  
CROCHET POUR ACCROCHER  
PANNEAUX - 19MM  
HOOK FOR HANGING PANELS - 19MM  
GANCIO PER APPENDERE PANNELLI  
-19MM  
**4616/034**

Fe	4870-4872 - 4874	€/u
----	------------------	-----

PANELES  
**19MM GROSOR**



ENGANCHE PARA COLGAR PANELES -  
10MM GROSOR  
CROCHET POUR ACCROCHER  
PANNEAUX - 10MM  
HOOK FOR HANGING PANELS -  
10MM  
GANCIO PER APPENDERE PANNELLI  
-10MM  
**4635/034**

Fe	4870-4872 - 4874	€/u
----	------------------	-----

PANELES  
**10MM GROSOR**

**! NUEVO**



CLIPAJE PARA ENCASTRAR PANELES  
FRONTALMENTE  
CLIPPING POUR ADAPTER LES  
PANNEAUX FRONTALEMENT  
CLIPPING TO FIT PANELS FRONTALLY  
CLIPPING PER ADATTARE I PANNELLI  
FRONTALMENTE  
**4607/028**

Fe	4870-4872 - 4874	€/u
----	------------------	-----

PANELES  
**10MM GROSOR**

# KADÍ ELEKTRIC - CREMALLERA ALU

PLÁSTICO  
PLASTIQUE  
PLASTIC  
PLASTICA  
**09**

## CONECTORES



NUEVO CONECTOR PLUG & PLAY, BLANCO  
CONNECTEUR PLUG & PLAY, BLANC  
CONNECTOR PLUG & PLAY, WHITE  
CONNETTORE PLUG & PLAY, BIANCO

84880/NOB  
84880/NON

Pla	3 m	24 W	€/u
		Max. 3A	

**! NUEVO**

## ACCESORIOS COMUNES



Hembra / Female

ENCHUFE + CABLE + DISTRIBUIDOR 6 SALIDAS CON MINI-CONECTORES 230V  
FICHE + CÂBLE + DISTRIBUTEUR 6 SORTIES AVEC MINI-PLUG 230V  
EURO-PLUG + CABLE + DISTRIBUTOR 6 WAYS-BLOCK WITH MINI-PLUG 230V  
SPINA CORRENTE + CAVO + DISTRIBUTORE 6 USCITE CON MINI-PLUG 230V

\*4771/009

Pla	3 m	230 V	€/u
		2,5 A	



CABLE CON MINI-CONECTORES 230V  
CABLE + MINI PLUG - 230V  
CABLE + MINI PLUG - 230V  
CAVO + MINI PLUG - 230V

\*4772/009

Pla	3 m	230 V	€/u
		2,5 A	

## DRIVER



DRIVER + 6 SALIDAS CON MINI-CONECTORES 24V  
DRIVER +DISTRIBUTEUR 6 SORTIES AVEC MINI-PLUG 24V  
DRIVER +DISTRIBUITOR 6 WAYS-BLOCK WITH MINI-PLUG 24V  
DRIVER +DISTRIBUITORE 6 USCITE CON MINI-PLUG 24V

\*4770/009

Pla	3 m	100 W	€/u
		230V>24V	

Hembra / Female  
Macho / Male



DRIVER + 6 SALIDAS CON MINI-CONECTORES 24V  
DRIVER + DISTRIBUTEUR 6 SORTIES AVEC MINI-PLUG 24V  
DRIVER + DISTRIBUTOR 6 WAYS-BLOCK WITH MINI-PLUG 24V  
DRIVER + DISTRIBUTORE 6 USCITE CON MINI-PLUG 24V

\*4769/009

Pla	1/2 M	24 V	€/u
		2,5 A	

# KADÍ ELEKTRIC - CREMALLERA ALU

PLÁSTICO  
PLASTIQUE  
PLASTIC  
PLASTICA  
**09**

## MINI-CONECTORES



CABLE MINI PLUG - ABIERTO 24V  
CABLE MINI PLUG - OVERTE 24V  
CABLE MINI PLUG - OPEN ENDED 24V  
CAVO MINI PLUG - APERTO 24V

4888/009

Pla	400 m	24 V	€/u
		2,5 A	



Hembra / Female

CABLE MINI PLUG - W PLUG 24V  
CABLE MINI PLUG - W PLUG 24V  
CABLE MINI PLUG - W PLUG 24V  
CAVO MINI PLUG -W PLUG 24V

\*4889/009

Pla	400 m	24 V	€/u
		2,5 A	

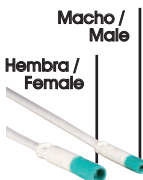

Macho / Male

Hembra / Female

CABLE CON MINI-CONECTORES 24V  
CABLE + MINI PLUG - 24V  
CABLE + MINI PLUG - 24V  
CAVO + MINI PLUG - 24V

\*4767/009 1M  
\*4768/009 2M

Pla	1/2 M	24 V	€/u
		2,5 A	



Hembra / Female

ENCHUFE + CABLE + MINI CONECTOR 230V  
FICHE + CÂBLE + MINI-PLUG 230V  
EURO-PLUG + CABLE + MINI-PLUG 230V  
SPINA CORRENTE + CAVO + MINI-PLUG 230V

\*4773/009

Pla	3 m	230 V	€/u
		2,5 A	

ANTIGUO

NUEVO



El nuevo conector substituirá al antiguo en todas las conexiones una vez agotadas las existencias del antiguo.



6 SALIDAS

DRIVER 100W, 24V / CONECTOR HEMBRA  
CONDUCTEUR 100W, 24V / CONNECTEUR FEMELLE  
DRIVER 100W, 24V / FEMALE CONNECTOR  
DRIVER 100W, 24V / CONNETTORE FEMMINA

6010/009

Pla	24 V 100W	€/u
	15cm	

PLÁSTICO  
PLASTIQUE  
PLASTIC  
PLASTICA  
**09**



CABLE CON MINI-CONECTORES 230V  
CABLE + MINI PLUG - 230V  
CABLE + MINI PLUG - 230V  
CAVO + MINI PLUG - 230V

6015/00B

Pla	3 m	230 V	€/u
		2,5 A	

**! NUEVO**

\* Recomendamos usar vidrios asegurizados o laminados. (NO INCLUIDO)

# KADÍ ELEKTRIC - CREMALLERA ALU

## ESTANTE VIDRIO 3895/1..

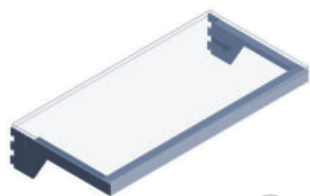

VIDRIO \* NO INCLUIDO

ESTANTE DE VIDRIO CON ILUMINACIÓN FRONTAL  
3895/1..  
**MONTADO**

Étagère en verre avec éclairage avant  
Glass shelf with front lighting  
Ripiano vetro con illuminazione frontale

1M máx. 29 cm

PL. M. ALU. M. ALL. NAT	BLANCO BLANC WHITE BIANCO	NEGRO NOIR BLACK NERO	COLOR COULEUR COLOR COLORE
01	0B	0N	0P

€/u

o o o

# KADÍ ELEKTRIC - CREMALLERA ALU

## ESTANTE VIDRIO 3894/1..

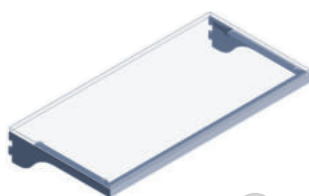

VIDRIO \* NO INCLUIDO

ESTANTE DE VIDRIO CON ILUMINACIÓN CENITAL FRONTAL  
3894/1..  
**MONTADO**

Étagère en verre avec éclairage zenithal frontal  
Glass shelf with frontal zenithal lighting  
Ripiano di vetro con illuminazione zenitale frontale

1M máx. 29 cm

BLANCO BLANC WHITE BIANCO	NEGRO NOIR BLACK NERO	COLOR COULEUR COLOR COLORE
0B	0N	0P

€/u

o o o

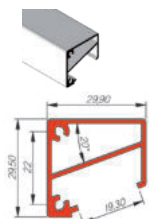

PERFIL ALUMINIO  
PROFIL EN ALUMINIUM  
ALUMINIUM PROFILE  
PROFILO DI ALUMINIO

4744/1..

Al	5 m	30x30	€/m
84602			

o o o o

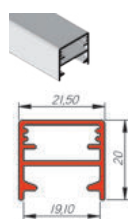

PERFIL ALUMINIO  
PROFIL EN ALUMINIUM  
ALUMINIUM PROFILE  
PROFILO DI ALUMINIO

4748/1..

Al	6 m	21,5x20	€/m
4893			

o o o

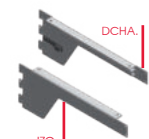

KIT CARTELAS ESTANTE VIDRIO CON ILUMINACIÓN  
KIT SUPPORTS VERRE ILLUMINATION  
GLASS LIGHTING BRACKETS KIT  
KIT MENSOLE VETRO ILLUMINAZIONE

4880/0..

Fe	4744-2556-4890	€/u
292 mm medida útil		

o o o



KIT CARTELAS ESTANTE VIDRIO CON ILUMINACIÓN  
KIT SUPPORTS VERRE ILLUMINATION  
GLASS LIGHTING BRACKETS KIT  
KIT MENSOLE VETRO ILLUMINAZIONE

4891/0..

Fe	4744-2556-4890	€/u
292 mm medida útil		

o o o

Cada cartela tiene 2 taladros para usar 1 perfil 4744  
Kit 2 cartelas: DERECHA (con conector) + IZQUIERDA

Kit 2 cartelas: DERECHA (con conector) + IZQUIERDA

PLÁSTICO PLASTIC PLASTICA

PLÁSTICO PLASTIC PLASTICA



DIFUSOR PLASTICO MATE  
DIFFUSEUR EN PLASTIQUE MAT  
MATT PLASTIC DIFFUSOR  
DIFUSORE PLASTICO OPACO

84602/109

Pla	2 m	4744	€/m
09			

o



DIFUSOR PLASTICO MATE  
DIFFUSEUR EN PLASTIQUE MAT  
MATT PLASTIC DIFFUSOR  
DIFUSORE PLASTICO OPACO

4893/109

Pla	2 m	4748	€/m
09			

o



LED CON MINI-CONECTOR 24V  
BANDE LED AVEC MINI-PLUG 24V  
LED STRIP WITH MINI-PLUG 24V  
STRACIA LED CON MINI-PLUG 24V

4890/109

Pla	1 m	5000 K	€/u
CRI>90 9,6 W 24V			

o

126 diodos (20λ); cortable cada 5,5 cm  
Cable, fil. wire, cavo: 26cm  
Ancho 8mm  
flexible y con cinta adhesiva  
fleible and self-adhesive



LED CON MINI-CONECTOR 24V  
BANDE LED AVEC MINI-PLUG 24V  
LED STRIP WITH MINI-PLUG 24V  
STRACIA LED CON MINI-PLUG 24V

4890/109

126 diodos (20λ); cortable cada 5,5 cm  
Cable, fil. wire, cavo: 26cm  
Ancho 8mm  
flexible y con cinta adhesiva  
fleible and self-adhesive

Pla	1 m	5000 K	€/u
CRI>90 9,6 W 24V			

o



VENTOSA TRANSPARENTE  
VENTOUSE  
SUCITON  
VENTOSA

2556/009

Pla	Ø14 mm	4880	€/u
-----	--------	------	-----

o



VENTOSA TRANSPARENTE  
VENTOUSE  
SUCITON  
VENTOSA

2556/009

Pla	Ø14 mm	4891	€/u
-----	--------	------	-----

o

# KADÍ ELEKTRIC - CREMALLERA ALU

## ESTANTE VIDRIO 3890/1..

\* Recomendamos usar vidrios segurizados o laminados. (NO INCLUIDO)

PL. M.	BLANCO	NEGRO	COLOR
ALU. M.	BLANC	NOIR	COULEUR
ALL. NAT.	WHITE	BLACK	COLOR
	BIANCO	NERO	COLORE
01	0B	0N	0P



VIDRIO \*  
NO INCLUIDO

ESTANTE DE VIDRIO  
RETROILUMINADO  
3890/1..  
**MONTADO**

Étagère en verre extra  
claire rétro-éclairé  
Backlit optical glass shelf  
Ripiano vetro extralight  
retroilluminato

1M máx.  
30  
cm

€/u

# KADÍ ELEKTRIC - CREMALLERA ALU

## ESTANTE VIDRIO 3891/1..

PL. M.	BLANCO	NEGRO	COLOR
ALU. M.	BLANC	NOIR	COULEUR
ALL. NAT.	WHITE	BLACK	COLOR
	BIANCO	NERO	COLORE
01	0B	0N	0P



VIDRIO \*  
NO INCLUIDO

ESTANTE DE  
VIDRIO CON  
ILUMINACIÓN  
FRONTAL  
3891/1..  
**MONTADO**

Étagère en verre avec  
éclairage zénithal frontal  
Glass shelf with frontal  
zenithal lighting  
Ripiano di vetro con  
illuminazione zenitale  
frontale

1M máx.  
30  
cm



junta goma incluida  
joint en caoutchouc  
inclus rubber gasket  
included giuntya di  
gomma inclusa

PERFIL ALUMINIO  
PROFIL LAME  
D'ALUMINIUM  
ALUMINIUM SLATWALL  
PROFILE  
PROFILO DOGATO  
ALLUMINIO

362/1...

Al	5 m	6-8mm	€/m
⊙	361/109		

o o o o

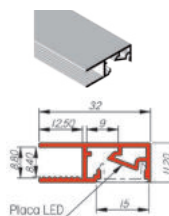

PERFIL ALUMINIO  
PROFIL EN ALUMINIUM  
ALUMINIUM PROFILE  
PROFILO DI ALLUMINIO

4892/1..

Al	5 m	32x11,2	€/m
⊙	4893 -4894		

o o o o



DCHA.

IZQ.

Para perfil 362  
Kit 2 cartelas:  
DERECHA (con  
conector) +  
IZQUIERDA

KIT CARTELAS ESTANTE  
VIDRIO CON  
ILUMINACIÓN  
KIT SUPPORTS VERRE  
ILLUMINATION  
GLASS LIGHTING  
BRACKETS KIT  
KIT MENSOLE VETRO  
ILLUMINAZIONE

386/0..

Fe	362 - 4890	€/u
⊙	68 mm medida útil	

o o o

PLÁSTICO  
PLASTIQUE  
PLASTIC  
PLASTICA

09



DIFUSOR DE PLÁSTICO MATE  
DIFFUSEUR EN PLASTIQUE MAT  
MATT PLASTIC DIFFUSOR  
DIFUSORE PLASTICO OPACO

4893/109

Pla	4892 -4894	€/m
⊙	2 m	

o



KIT 2 TAPAS FINALES LATERALES  
KIT 2 COUVERTURE LATÉRALE FINALE  
KIT 2 LATERAL END CAP  
KIT 2 COPERTURA LATERALE FINALE

4894/00N  
4894/00B

Pla	4892 -4893	€/u
⊙	32x11,2	

o o



126 diodos (20A);  
cortable cada  
5.5 cm  
Cable, fil, wire,  
cavo: 26cm  
Ancho 8mm

flexible y con  
cinta adhesiva  
fleible and  
self-adhesive

LED CON  
MINI-CONECTOR 24V  
BANDE LED AVEC  
MINI-PLUG 24V  
LED STRIP WITH  
MINI-PLUG 24V  
STRACIA LED CON  
MINI-PLUG 24V

4890/109

Pla	1 m	5000 K	€/u
⊙	CRI>90	9,6 W 24V	

o



MINI  
PLUG

flexible y con  
cinta adhesiva  
fleible and  
self-adhesive

30 CM CABLE PLANO ADHESIVO  
30 CM CÂBLE ADHÉSIF PLAT  
30 CM FLAT ADHESIVE CABLE  
30 CM CAVO ADESIVO PIATTO

4895/009

Pla	1 m	24V-2,5A	€/u
-----	-----	----------	-----

o

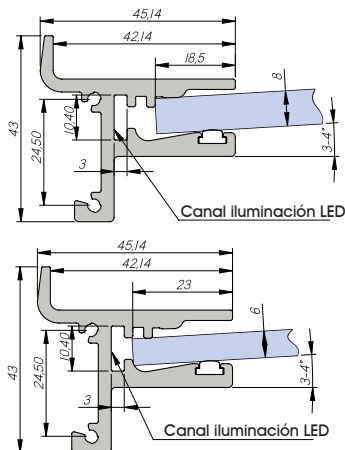

ES • MÁXIMA  
MEDIDA ESTANTE  
RECOMENDADA:  
100 X 30 CM.

FR • Maximum  
recommended  
shelf size: 100 x  
30 cm.

IT • Dimensione  
massima  
raccomandata  
dello scaffale:  
100 x 30 cm.

EN • Taille  
maximale de  
l'étagère  
recommandée:  
100 x 30 cm.

# KADÍ ELEKTRIC - CREMALLERA ALU

## ESTANTE MADERA 3896/1..

\*  **MADERA NO INCLUIDA**

PL. M ALU. M ALU. M ALL. NAT	BLANCO BLANC WHITE BIANCO	NEGRO NOIR BLACK NERO	COLOR COULEUR COLOR COLORE
01	0B	0N	0P

ESTANTE DE MADERA CON ILUMINACIÓN FRONTAL EMPOTRADA Y PERFIL DE ALUMINIO (3971) 3896/1..

**SIN MONTAJE**  
Étagère en bois avec éclairage zénithal monté sur l'étagère  
Wooden shelf with zenithal lighting mounted on the shelf  
Ripiano legno con illuminazione zenitale impotrata nel ripiano

**MADERA NO INCLUIDA**

1M máx.  cm

€/u

# KADÍ ELEKTRIC - CREMALLERA ALU

## ESTANTE MADERA 5370/1..

PL. M ALU. M ALU. M ALL. NAT	BLANCO BLANC WHITE BIANCO	NEGRO NOIR BLACK NERO	COLOR COULEUR COLOR COLORE
01	0B	0N	0P

ESTANTE DE MADERA CON ILUMINACIÓN FRONTAL EMPOTRADA Y PERFIL DE ALUMINIO (3971) 5370/1..

**SIN MONTAJE**  
Étagère en bois avec éclairage zénithal monté sur l'étagère  
Wooden shelf with zenithal lighting mounted on the shelf  
Ripiano legno con illuminazione zenitale impotrata nel ripiano

**MADERA NO INCLUIDA**

1M máx.  cm

€/u

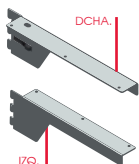

**KIT CARTELAS ESTANTE MADERA CON ILUMINACIÓN**  
KIT SUPPORTS BOIS ILLUMINATION  
WOOD LIGHTING BRACKETS KIT  
KIT MENSOLE LEGNO  
ILLUMINAZIONE

4885/0..

Fe	⊙ 4890	€/u
		350 mm medida útil

Kit 2 cartelas: DERECHA (con conector) + IZQUIERDA



**KIT PERFIL ALUMINIO CON DIFUSOR**  
KIT PROFIL EN ALUMINIUM AVEC DIFFUSEUR  
KIT PROFILO IN ALLUMINIO CON DIFFUSORE

3971/1..

Al		2 m	18x9	€/m
----	---	-----	------	-----

Medidas mecanizado 16 x 6.8 mm

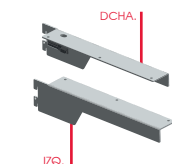

**KIT CARTELAS ESTANTE MADERA CON ILUMINACIÓN**  
KIT SUPPORTS BOIS ILLUMINATION  
WOOD LIGHTING BRACKETS KIT  
KIT MENSOLE LEGNO  
ILLUMINAZIONE

5370/0..

Fe	⊙ 4890	€/u
		290 mm medida útil

Kit 2 cartelas: DERECHA (con conector) + IZQUIERDA



**KIT PERFIL ALUMINIO CON DIFUSOR**  
KIT PROFIL EN ALUMINIUM AVEC DIFFUSEUR  
KIT PROFILO IN ALLUMINIO CON DIFFUSORE

3971/1..

Al		2 m	18x9	€/m
----	---	-----	------	-----

Medidas mecanizado 16 x 6.8 mm

4881/301  
Medidas mecanizado 18 x 6.2 mm

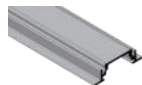

**PERFIL ALUMINIO, DIFUSOR DE PLASTICO MATE, TAPA FINAL, 2 U.**  
PROFIL EN ALUMINIUM, DIFFUSEUR EN PLASTIQUE MAT, EMBOUT, 2 U.  
ALUMINIUM PROFILE, MATT PLASTIC DIFUSOR, END CAP, 2 U.  
PROFILO DI ALLUMINIO, DIFUSORE PLASTICO OPACO, TAPPO DI APRIFESTA, 2 U.

Al		3 m	24x7	€/u
	⊙ 4882			

Pla		2 m		€/u
	⊙ 4892-4894			

Pla	⊙ 4881	€/u
-----	--------	-----

PLÁSTICO PLASTIQUE PLASTICA 09

4882/159



4883/009



4881/301  
4882/159  
4883/009

				o
				o
				o

4881/301  
Medidas mecanizado 18 x 6.2 mm

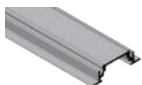

4882/159



4883/009

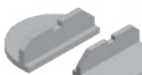

**PERFIL ALUMINIO, DIFUSOR DE PLASTICO MATE, TAPA FINAL, 2 U.**  
PROFIL EN ALUMINIUM, DIFFUSEUR EN PLASTIQUE MAT, EMBOUT, 2 U.  
ALUMINIUM PROFILE, MATT PLASTIC DIFUSOR, END CAP, 2 U.  
PROFILO DI ALLUMINIO, DIFUSORE PLASTICO OPACO, TAPPO DI APRIFESTA, 2 U.

Al		3 m	24x7	€/u
	⊙ 4882			

Pla		2 m		€/u
	⊙ 4892-4894			

Pla	⊙ 4881	€/u
-----	--------	-----

PLÁSTICO PLASTIQUE PLASTICA 09

4881/301  
4882/159  
4883/009

				o
				o
				o

126 diodos (20λ); cortable cada 5.5 cm  
Cable, fil, wire, cavo: 40cm  
Ancho 8 mm  
flexible y con cinta adhesiva  
fleible and self-adhesive

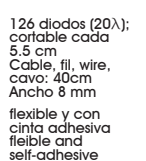

**LED CON MINI-CONECTOR 24V**  
BANDE LED AVEC MINI-PLUG 24V  
LED STRIP WITH MINI-PLUG 24V  
STRACIA LED CON MINI-PLUG 24V

4890/009

Pla		1 m	5000 K	€/u
	⊙ CRI>90	⊙	9,6 W 24V	

126 diodos (20λ); cortable cada 5.5 cm  
Cable, fil, wire, cavo: 40cm  
Ancho 8 mm  
flexible y con cinta adhesiva  
fleible and self-adhesive



**LED CON MINI-CONECTOR 24V**  
BANDE LED AVEC MINI-PLUG 24V  
LED STRIP WITH MINI-PLUG 24V  
STRACIA LED CON MINI-PLUG 24V

4890/009

Pla		1 m	5000 K	€/u
	⊙ CRI>90	⊙	9,6 W 24V	

				o
--	--	--	--	---

# KADÍ ELEKTRIC - CREMALLERA ALU

## BARRA ACCESORIOS FRONTAL 4910/1..

\* Recomendamos usar vidrios segurizados o laminados. (NO INCLUIDO)

PL. M. ALU. M. ALU. M. ALL. NAT	BLANCO BLANC WHITE BIANCO	NEGRO NOIR BLACK NERO	COLOR COULEUR COLOR COLORE
01	0B	0N	0P



Kit compuesto por:  
- Cartelas Ref.4875  
-Tubo rectangular Ref.4900/108  
-LED de 1m

1M máx. 8 cm

BARRA DE CUELQUE PARA ACCESORIOS FRONTALES CON ILUMINACIÓN Y PROTECCIÓN PLÁSTICA

4910/1..

**MONTADO**

Barre de suspension pour accessoires avant avec éclairage  
Hanger bar for front accessories with lighting  
Barra appendiabili per accessori frontal con illuminazione

€/u

# KADÍ ELEKTRIC - CREMALLERA ALU

## BARRA ACCESORIOS FRONTAL 3901/1..

PL. M. ALU. M. ALU. M. ALL. NAT	BLANCO BLANC WHITE BIANCO	NEGRO NOIR BLACK NERO	COLOR COULEUR COLOR COLORE
01	0B	0N	0P

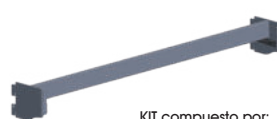

Kit compuesto por:  
- Cartelas Ref.4878  
-Tubo rectangular Ref.4900/108  
-LED de 1m

1M máx. 7 cm

BARRA DE CUELQUE PARA ACCESORIOS FRONTALES CON ILUMINACIÓN Y PROTECCIÓN PLÁSTICA SUPERIOR

4901/1..

**MONTADO**

Barre de suspension pour accessoires avant avec éclairage  
Hanger bar for front accessories with lighting  
Barra appendiabili per accessori frontal con illuminazione

€/u

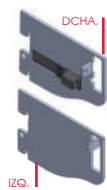

Kit 2 cartelas: DERECHA (con conector) + IZQUIERDA

**KIT CARTELAS BARRA ACCESORIOS**  
KIT SUPPORT BARRÉ ACCESSOIRES  
KIT BRACKET FOR ACCESSORIES ROD  
KIT MENSOLA TUBO PORTA-ACCESSORI

4875/00B

Fe	⊙ 4900	€/u
	81 mm medida útil	



Kit 2 cartelas: DERECHA (con conector) + IZQUIERDA

**KIT CARTELAS BARRA ACCESORIOS**  
KIT SUPPORT BARRÉ ACCESSOIRES  
KIT BRACKET FOR ACCESSORIES ROD  
KIT MENSOLA TUBO PORTA-ACCESSORI

4878/00.

Fe	⊙ 4900	€/u
	68 mm medida útil	

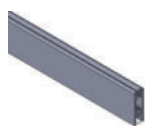

LED no incluido. LED recomendado de 5mm de ancho. Incluye perfil de plástico superior y difusor interior.

**KIT TUBO RECTANGULAR PARA ILUMINACIÓN 30X10MM**  
KIT TUBE RECTANGULAIRE POUR ECLAIRAGE 30X10MM  
KIT RECTANGULAR TUBE FOR LIGHTING 30X10MM  
KIT TUBO RETTANGOLARE PER ILLUMINAZIONE 30X10MM

4900/10.

Al	⊔ 6 m	30x10	€/m
	⊙ 84602		

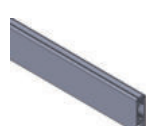

LED no incluido. LED recomendado de 5mm de ancho. Incluye perfil de plástico superior y difusor interior.

**KIT TUBO RECTANGULAR PARA ILUMINACIÓN 30X10MM**  
KIT TUBE RECTANGULAIRE POUR ECLAIRAGE 30X10MM  
KIT RECTANGULAR TUBE FOR LIGHTING 30X10MM  
KIT TUBO RETTANGOLARE PER ILLUMINAZIONE 30X10MM

4900/10.

Al	⊔ 6 m	30x10	€/m
	⊙ 84602		



Para perfil 4900

**TAPA PARA TUBO RECTANGULAR 30X10MM**  
CAPUCHON DE TUBE RECTANGULAIRE 30X10MM  
TUBE CAP RECTANGULAR 30X10MM  
TAPPO DEL TUBO RETTANGOLARE 30X10MM

4904/00.

Fe	92 mm	⊙ 4900	€/u
----	-------	--------	-----



182 diodos (20λ); cortable cada 3,8 cm  
Cable, fil, wire, cavo: 45 mm  
Ancho 5mm

**LED CON MINI-CONECTOR 24V**  
BANDE LED AVEC MINI-PLUG 24V  
LED STRIP WITH MINI-PLUG 24V  
STRACIA LED CON MINI-PLUG 24V

4901/109

PLÁSTICO  
PLASTIQUE  
PLASTIC  
PLASTICA

09

Pla	⊔ 1 m	⚡ 5000 K	€/u
	⊙ CRI>90	⊙ 15,3W 24V	



182 diodos (20λ); cortable cada 3,8 cm  
Cable, fil, wire, cavo: 40cm  
Ancho 5mm

flexible y con cinta adhesiva  
fleible and self-adhesive

**LED CON MINI-CONECTOR 24V**  
BANDE LED AVEC MINI-PLUG 24V  
LED STRIP WITH MINI-PLUG 24V  
STRACIA LED CON MINI-PLUG 24V

4910/109

Pla	⊔ 1 m	⚡ 5000 K	€/u
	⊙ CRI>90	⊙ 15,3W 24V	

PLÁSTICO  
PLASTIQUE  
PLASTIC  
PLASTICA

09

## EJEMPLO DE APLICACIÓN

Barras de accesorios con cuelgue frontal.

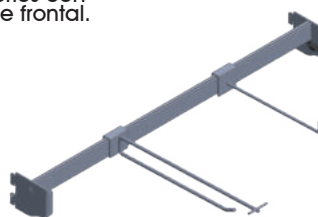

\* Recomendamos usar vidrios segurizados o laminados. (NO INCLUIDO)

# KADÍ ELEKTRIC - CREMALLERA ALU

## PENDERIE 3897/1..



ESTANTE + BARRA DE CUELGUE LATERAL CON ILUMINACIÓN Y PROTECCIÓN PLÁSTICA SUPERIOR  
3897/1..

### MONTADO

Tablette + barre de suspension latérale avec éclairage  
Shelf + side hanging bar with lighting  
Mensola + barra appendiabiti laterale con illuminazione

VIDRIO / MADERA NO INCLUIDO



1M máx. 29 cm

PARA MADERA O VIDRIO



PL. M	BLANCO	NEGRO	COLOR
ALU. M	BLANC	NOIR	COULEUR
ALL. NAT	WHITE	BLACK	COLOR
	BIANCO	NERO	COLORE
01	0B	0N	0P

# KADÍ ELEKTRIC - CREMALLERA ALU

## BARRA CUELGUE LATERAL 3898/1..



BARRA DE CUELGUE LATERAL CON ILUMINACIÓN Y PROTECCIÓN PLÁSTICA SUPERIOR  
3898/1..

### MONTADO

Barre de suspension latérale avec éclairage  
Side hanger bar with lighting  
Barra appendiabiti laterale con illuminazione

1M máx. 29 cm

PL. M	BLANCO	NEGRO	COLOR
ALU. M	BLANC	NOIR	COULEUR
ALL. NAT	WHITE	BLACK	COLOR
	BIANCO	NERO	COLORE
01	0B	0N	0P

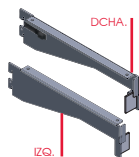

Kit 2 cartelas: DERECHA (con conector) + IZQUIERDA

KIT CARTELAS BARRA CUELGUE CON ESTANTE  
KIT SUPPORT BARRE ACCESSOIRES  
KIT BRACKET FOR ACCESSORIES ROD  
KIT MENSOLA TUBO PORTA-ACCESSORI  
4727/0..

Fe	4900	€/u
	290 mm medida útil	

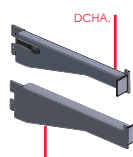

Kit 2 cartelas: DERECHA (con conector) + IZQUIERDA

KIT CARTELAS BARRA ACCESORIOS  
KIT SUPPORT BARRE ACCESSOIRES  
KIT BRACKET FOR ACCESSORIES ROD  
KIT MENSOLA TUBO PORTA-ACCESSORI  
4726/0..

Fe	4900	300 mm	€/u
		290 mm medida útil	



LED no incluido. LED recomendado de 5mm de ancho. Incluye perfil de plástico superior y difusor interior.

TUBO RECTANGULAR PARA ILUMINACIÓN 30X10MM CON PLETINA DE REFUERZO  
KIT TUBE RECTANGULAIRE POUR ECLAIRAGE 30X10MM AVEC PLAQUE DE RENFORT  
KIT RECTANGULAR TUBE FOR LIGHTING 30X10MM WITH REINFORCING PLATE  
KIT TUBO RETTANGOLARE PER ILLUMINAZIONE 30X10MM CON PIASTRA DI RINFORZO  
4900/12.  
CON ALMA DE ACERO INOX

Al	1 m	30x10	€/u
		4901	

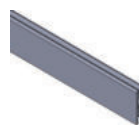

LED no incluido. LED recomendado de 5mm de ancho. Incluye perfil de plástico superior y difusor interior.

TUBO RECTANGULAR PARA ILUMINACIÓN 30X10MM CON PLETINA DE REFUERZO  
KIT TUBE RECTANGULAIRE POUR ECLAIRAGE 30X10MM AVEC PLAQUE DE RENFORT  
KIT RECTANGULAR TUBE FOR LIGHTING 30X10MM WITH REINFORCING PLATE  
KIT TUBO RETTANGOLARE PER ILLUMINAZIONE 30X10MM CON PIASTRA DI RINFORZO  
4900/12.  
CON ALMA DE ACERO INOX

Al	1 m	30x10	€/u
		4901/109	



182 diodos (20λ); cortable cada 3.8 cm  
Cable, fil. wire, cavo: 40cm  
Ancho 5mm  
flexible y con cinta adhesiva  
fleible and self-adhesive

LED CON MINI-CONECTOR 24V  
BANDE LED AVEC MINI-PLUG 24V  
LED STRIP WITH MINI-PLUG 24V  
STRIACIA LED CON MINI-PLUG 24V  
4910/109

Pla	1 m	5000 K	€/u
		CRI>90	15,3W 24V

PLÁSTICO PLASTIQUE PLASTICA 09



182 diodos (20λ); cortable cada 3.8 cm  
Cable, fil. wire, cavo: 40cm  
Ancho 5mm  
flexible y con cinta adhesiva  
fleible and self-adhesive

LED CON MINI-CONECTOR 24V  
BANDE LED AVEC MINI-PLUG 24V  
LED STRIP WITH MINI-PLUG 24V  
STRIACIA LED CON MINI-PLUG 24V  
4910/109

Pla	1 m	5000 K	€/u
		CRI>90	15,3W 24V

PLÁSTICO PLASTIQUE PLASTICA 09



VENTOSA TRANSPARENTE  
VENTOUSE  
SUCITON  
VENTOSA  
2556/009

Pla	14 mm	4726	€/u
-----	-------	------	-----



# KADÍ ELEKTRIC - CREMALLERA ALU

## PERROQUET 4725/0..

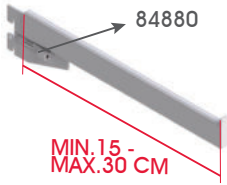

PERROQUET PLANO CON ILUMINACIÓN PARA CUELGUE FRONTAL 4725/0..

### MONTADO

Chien plat avec éclairage pour suspension avant  
Flat doggie with lighting for front hanging  
Cagnolino piatto con illuminazione per sospensione frontale

Fe 300 mm

PL. M	BLANCO	NEGRO	COLOR
ALU. M	BLANC	NOIR	COULEUR
ALL. M	WHITE	BLACK	COLOR
ALL. NAT	BIANCO	NERO	COLORE
01	0B	0N	0P
			€/u

# KADÍ ELEKTRIC - CREMALLERA ALU

## NUEVAS CARTELAS 4636/0..



ESTANTE VOLADO DE MADERA CON ILUMINACIÓN DE GROSOR 19MM

### KIT CARTELAS 4636/1..

#### SIN MONTAJE

Étagère en bois avec éclairage, épaisseur 19 mm  
Wooden shelf with lighting, 19mm thick  
Mensola in legno con illuminazione, spessore 19 mm

MADERA \* NO INCLUIDA

Fe 3971

PL. M	BLANCO	NEGRO	COLOR
ALU. M	BLANC	NOIR	COULEUR
ALL. M	WHITE	BLACK	COLOR
ALL. NAT	BIANCO	NERO	COLORE
01	0B	0N	0P
			€/u



CARTELA DER

Kit 2 cartelas 4636 DER. - Con conector IZQ. - Sin conector



Kit 2 cartelas: DERECHA (con conector) + IZQUIERDA

KIT CARTELAS ESTANTE MADERA CON ILUMINACIÓN KIT SUPPORTS BOIS ILLUMINATION WOOD LIGHTING BRACKETS KIT KIT MENSOLE LEGNO ILLUMINAZIONE 4636/0..

Fe 4890 350 mm medida útil €/u

0 0 0



Medidas mecanizado 16 x 6.8 mm

KIT PERFIL ALUMINIO CON DIFUSOR KIT PROFIL EN ALUMINIUM AVEC DIFFUSEUR KIT PROFILO IN ALLUMINIO CON DIFFUSORE 3971/1..

Al 2 m 18x9 €/m

0



126 diodos (20λ); cortable cada 5.5 cm  
Cable, fil., wire, cavo: 26cm  
Ancho 8mm  
flexible y con cinta adhesiva flexible and self-adhesive

LED CON MINI-CONECTOR 24V BANDE LED AVEC MINI-PLUG 24V LED STRIP WITH MINI-PLUG 24V STRIACIA LED CON MINI-PLUG 24V 4890/109

Pla 1 m 5000 K 9,6 W 24V €/u

PLÁSTICO PLASTIQUE PLASTIC PLASTICA

09

0



NUEVO

# KADÍ - CREMALLERAS

GUÍAS-CREMALLERA EN ALUMINIO - CRÉMALLÈRES EN ALUMINIUM  
RACKS IN ALUMINIUM - PROFILI CREMAGLIERA IN ALLUMINIO

## MEDIDAS CREMALLERAS Y MECANIZACIONES

mesures crémailières et mécanisations  
racks sizes and mechinings  
misure cremagliere e meccanizzazioni

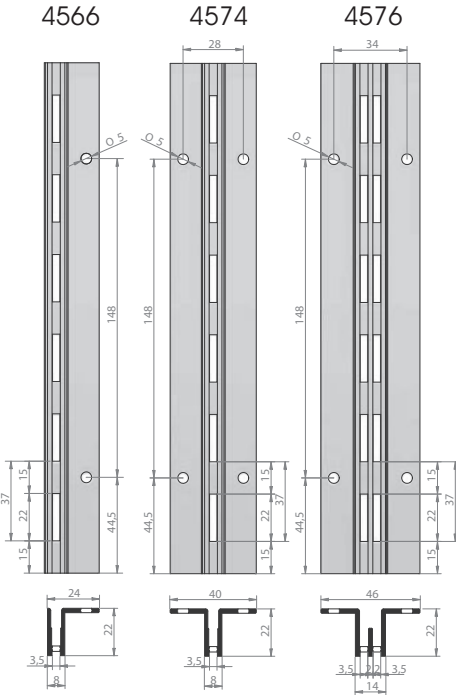

KADÍ OMEGA

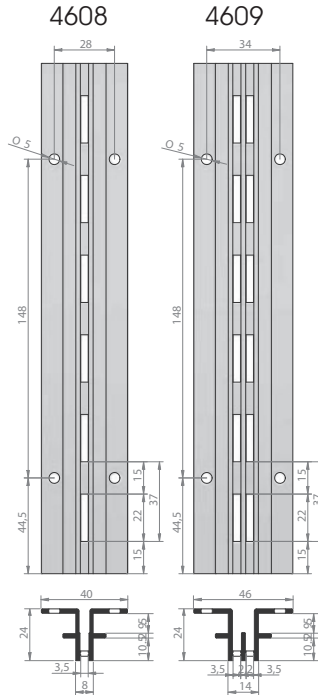

KADÍ ALA

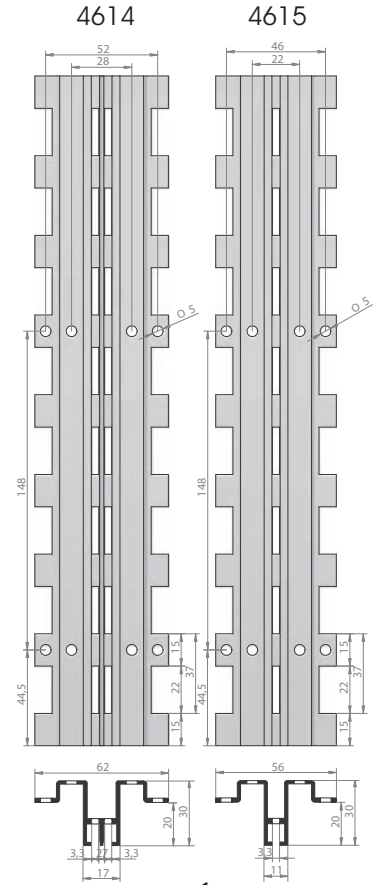

KADÍ DUO

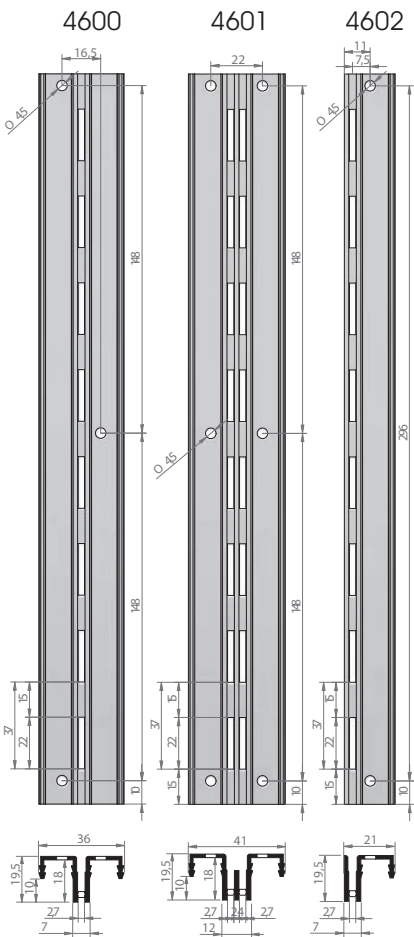

KADÍ CLASSIC

**CREMALLERA EMPOTRABLE FRONTALMENTE**

**NUEVO**

**KADÍ EMPOTRABLE ALUMINIO 4567**

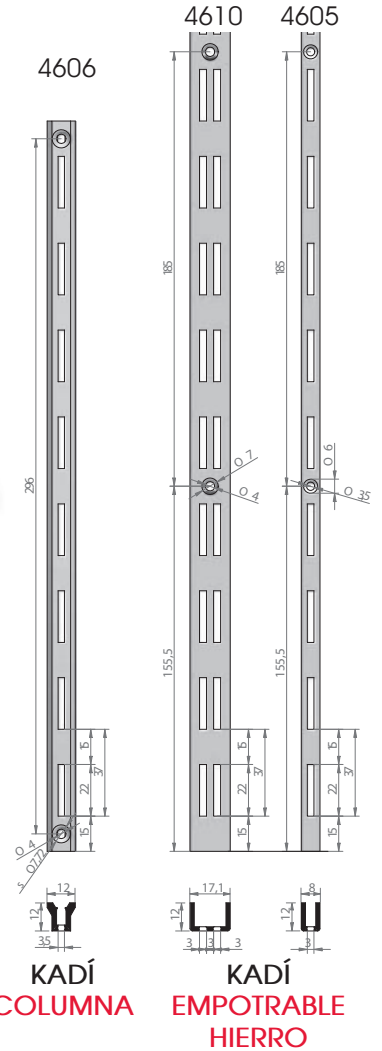

KADÍ COLUMN

KADÍ EMPOTRABLE HIERRO

# KADÍ - CREMALLERAS

GUÍAS-CREMALLERA EN ALUMINIO - CRÉMAILLÈRES EN ALUMINIUM  
RACKS IN ALUMINIUM - PROFILI CREMAGLIERA IN ALLUMINIO

## KADÍ OMEGA

**1** CREMALLERAS FIJADAS A PANEL  
crémaillères fixées à le panneau  
racks fixed to the panel  
cremagliere fissate al pannello

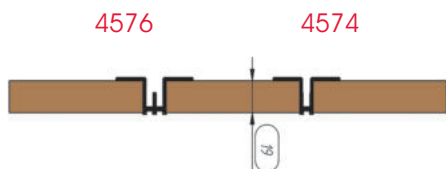
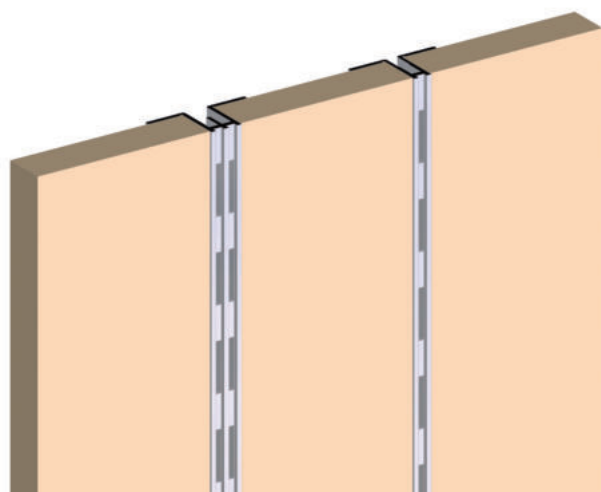

**2** CREMALLERAS EMPOTRADAS CON REMATES 4575 Y 4577  
crémaillères insérées avec cabochones 4575 et 4577  
racks inserted with end-caps 4575 and 4577  
cremagliere inserite da dietro con coprifesta 4575 e 4577

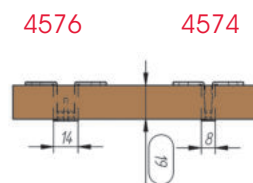
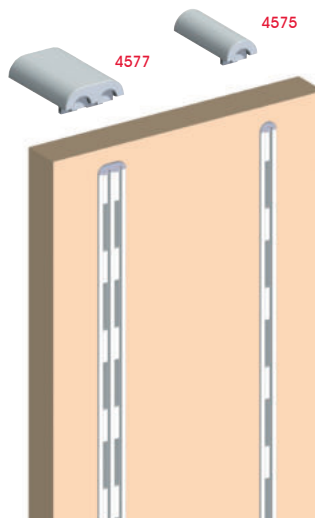

**3** CREMALLERAS FIJADAS DIRECTAMENTE A PARED  
crémaillères fixées directement au mur  
racks fixed directly to the wall  
cremagliere fissate direttamente a parete

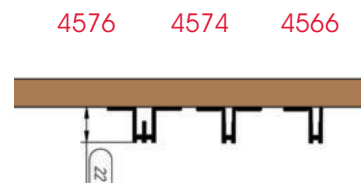
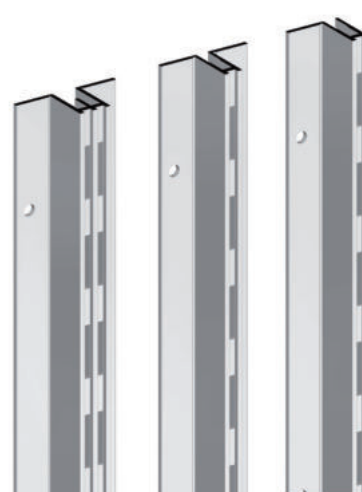

NOTA: También válido para montaje con botones 4780, 4781, 4782.

## KADÍ ALA

**1** ENSAMBLE MACHIHEMBADO  
assemblage rainure-langouette  
tongue-and-groove joint  
unione a incastro

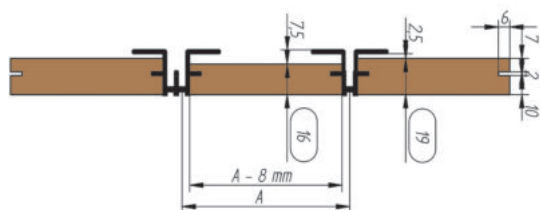
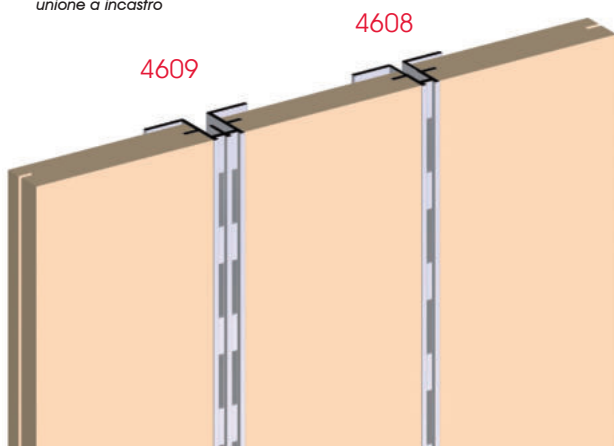

**2** BOTONES 4780, 4781 Y 4782  
crochetes de maintien 4780,  
4781 et 4782  
panel hooks 4780, 4781  
and 4782  
fermapannelli 4780, 4781  
e 4782

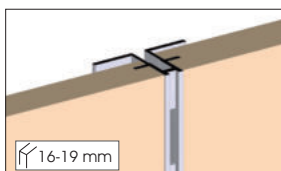
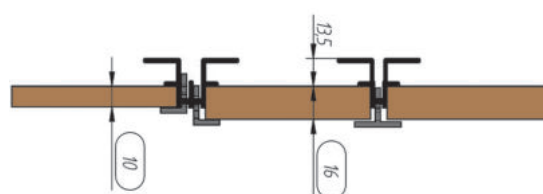
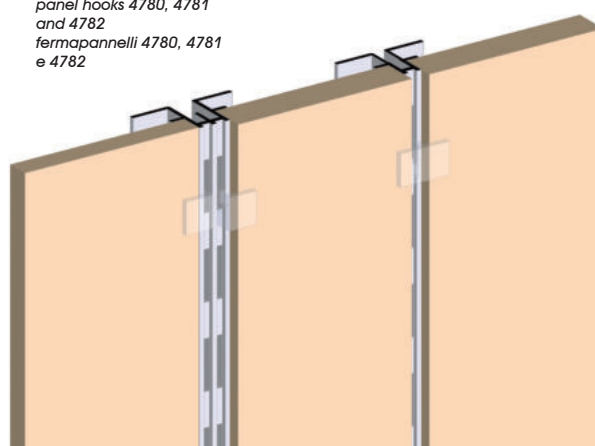

ENSAMBLE CON MADERA DE 16MM O 19MM  
assembler avec du bois de 16 mm ou 19 mm  
assemble with 16mm or 19mm  
assemblare con legno 16mm o 19mm

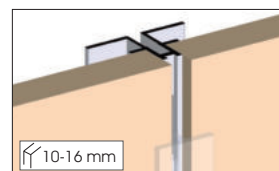

ENSAMBLE CON MADERA DE 10MM O 16MM  
assembler avec du bois de 10 mm ou 16 mm  
assemble with 10mm or 16mm  
assemblare con legno 10mm o 16mm

# KADÍ - CREMALLERAS

GUÍAS-CREMALLERA EN ALUMINIO - CRÉMAILLÈRES EN ALUMINIUM  
RACKS IN ALUMINIUM - PROFILI CREMAGLIERA IN ALLUMINIO

PATENTADO - BREVETÉ - PATENTED - BREVETTATO

## KADÍ CLASSIC

### EJEMPLOS DE PANELADO CON LAS GUÍAS 4600, 4601 Y 4602

Exemples of paneling with racks 4600, 4601 and 4602  
Exemples de panneaux avec des crémailières 4600, 4601 et 4602  
Esempi di montaggio dei pannelli con i profili cremagliera 4600, 4601 e 4602

**1** CON "GRAPA CLIP" 4607  
avec "GRAPA CLIP" 4607  
with "GRAPA CLIP" 4607  
con "GRAPA CLIP" 4607

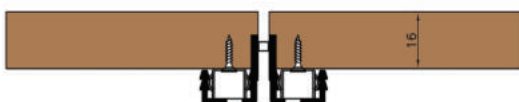
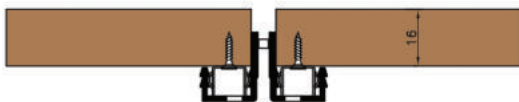
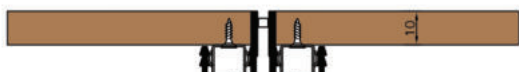
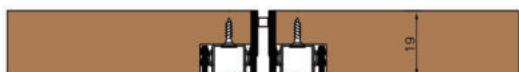
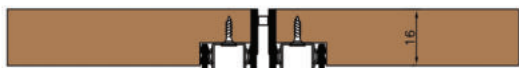

**3** EMPOTRADO SIN GRAPA  
encastré sans clip  
recessed without clip  
incasso senza clip



La serie **Classic** y el **casquillo 4699 no admiten** cartelas con los **ganchos del talón pintados**; el troquel tiene una anchura de 2,7 mm y la cartela pintada un espesor de casi 3 mm. **Alu System solo tiene stock de cartelas con el talón sin pintar.** La parte no pintada nunca queda visible desde el exterior. En caso de precisar los talones pintados consultar con departamento comercial.

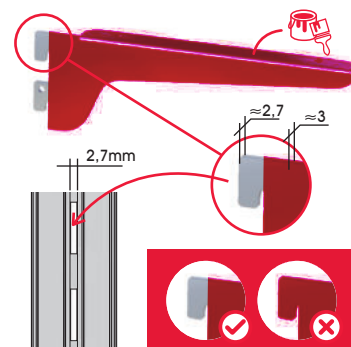

Puede tener algún tipo de oxidación. Alusystem no se hará cargo del posible deterioro.

**2** CON BOTONES 4780 - 4781 - 4782  
avec boutons 4780 - 4781 - 4782  
with buttons 4780 - 4781 - 4782  
con bottoni 4780 - 4781 - 4782

4780



4781



4782

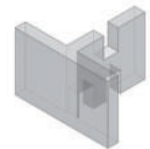

GUÍA VISTA

- con cremalleras 4600, 4601 y 4602  
- panel de 10 mm sin rebajar

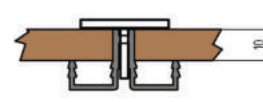

GUÍA OCULTA (6 mm)

- con cremalleras 4600, 4601 y 4602  
- con panel de 16 mm sin rebajar

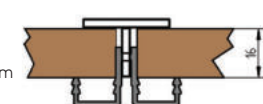

## KADÍ HIERRO EMPOTRABLES

**1** ENSAMBLE  
assemblage rainure-langouette  
tongue-and-groove joint  
unione a incastro

SE ACONSEJAN TORNILLOS AVELLANADOS CON CABEZA PLANA Ø 5,5 mm (ej. DIN7997)

Sont recommandés vis à tête fraisée avec tête plate Ø 5,5 mm (ej. DIN7997)

We recommende countersunk screws with flat head Ø 5,5 mm (ej. DIN7997)

Si consiglano viti svasate con testa piana Ø 5,5 mm (ej. DIN7997)

**4605 Y 4610**

COMPATIBLES CON ACCESORIOS SISTEMA KADÍ  
COMPATIBLE AVEC ACCESSOIRES SYSTEME KADÍ  
COMPATIBLE WITH KADÍ SYSTEM FITTINGS  
COMPATIBILE CON ACCESSORI SISTEMA KADÍ

Disponibile también en aluminio  
REF 4567

4605

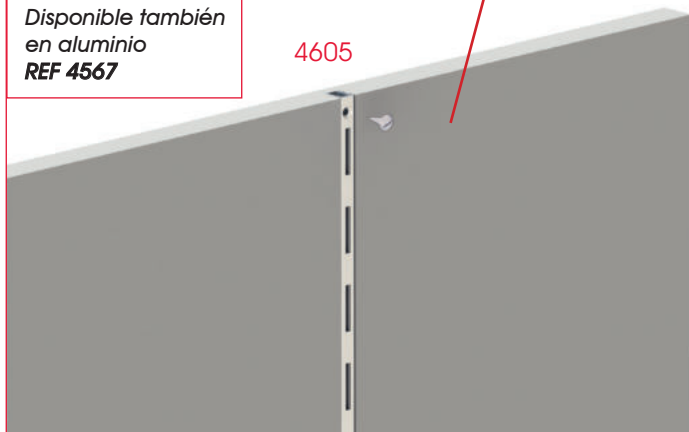

4610

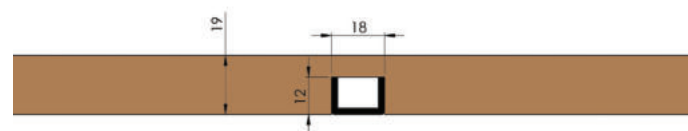
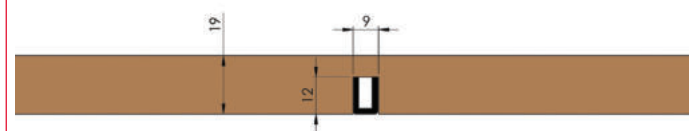
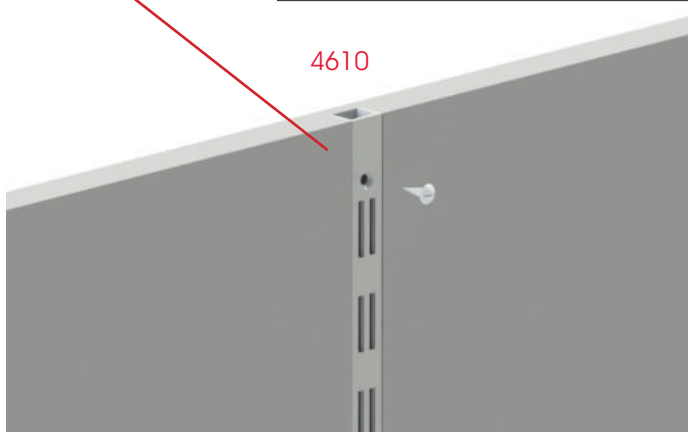

# KADÍ - CREMALLERAS

GUÍAS-CREMALLERA EN ALUMINIO - CRÉMAILLÈRES EN ALUMINIUM  
RACKS IN ALUMINIUM - PROFILI CREMAGLIERA IN ALLUMINIO

PATENTADO - BREVETÉ - PATENTED - BREVETTATO

## 4567 -

### GUÍA CREMALLERA EMPOTRABLE DE ALUMINIO - 1 CANAL

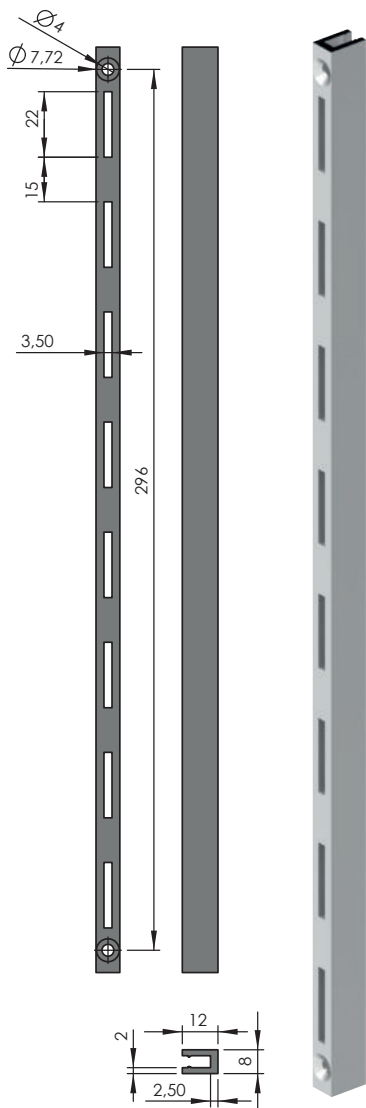

#### Acabados



Aluminio plata mate (01), blanco (0B), negro (0N), color (0P).

Posibilidad de pintar en cualquier RAL.

#### Medidas

Alto de entre ejes de fijación: 296 mm  
Ancho/Profundo: 8 mm X 12 mm  
Longitud de las barras: 5 metros.

#### Atornillado. Tornillos DIN.7997

La guía lleva incorporados unos agujeros avellanados cada 296mm para poder atornillar a la madera con tornillos DIN.7997.



#### Remates finales 84567

Para poder encastrar la guía es necesario crear un fresado a la madera. Los finales de los fresados crean unas terminaciones circulares para los cuales alusystem ofrece unos embellecedores como remates para un acabado de calidad.

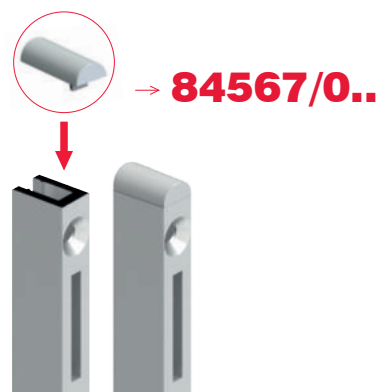

#### Empotrable

El acabado es limpio y mantiene una estética harmónica con la superficie.

#### Accesorios

Compatible con toda la gama de accesorios del sistema Kadí.

#### Paso Superficie

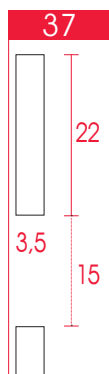

También permite la posibilidad de atornillar encima de una melamina.

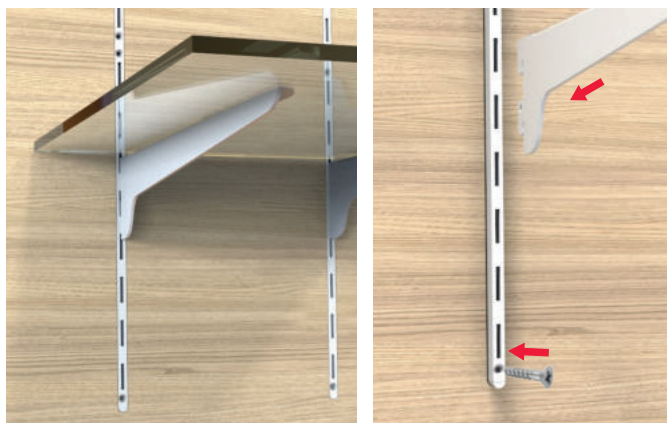

**NUEVO**

# KADÍ - CREMALLERAS

GUÍAS-CREMALLERA EN ALUMINIO - CRÉMAILLÈRES EN ALUMINIUM  
RACKS IN ALUMINIUM - PROFILI CREMAGLIERA IN ALLUMINIO

## KADÍ DUO 4615 y KADÍ DOBLE DUO 4614 EMPOTRADAS EN PANEL

RACKS DUO 4615 AND DOBLE DUO 4614 EMBEDDED IN THE PANEL  
CRÉMAILLÈRES DUO 4615 AND DOBLE DUO 4614 INTÉGRÉS DANS LE PANNEAU  
PROFILI CREMAGLIERA DUO 4615 E DOBLE DUO 4614 INSERITI NEL PANNELLO

### 4615 - KADÍ DUO

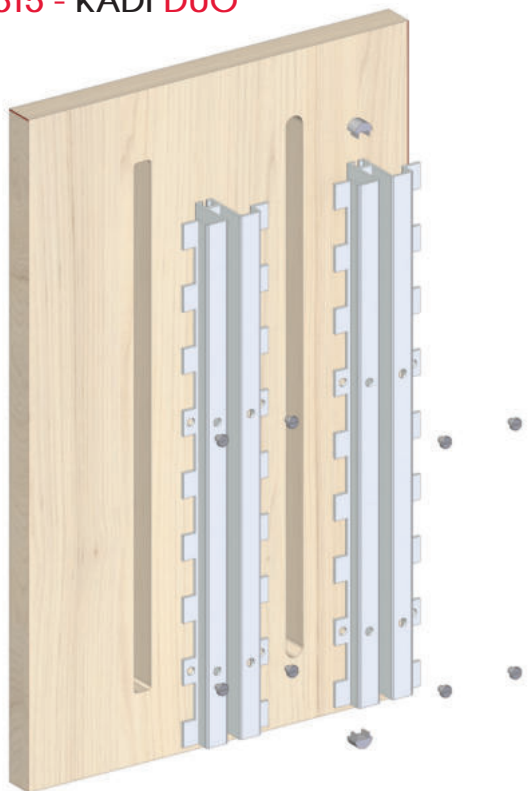

empotrado  
con tapas 4617

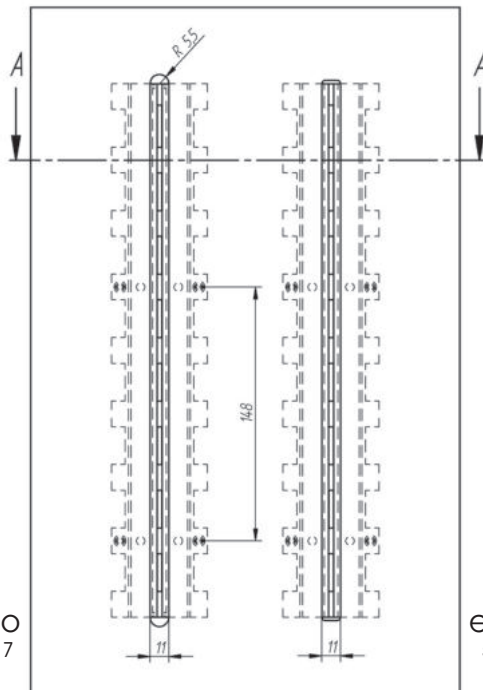

empotrado  
sin tapas 4617

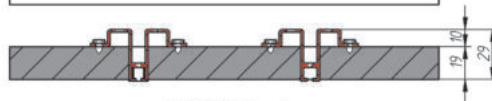

CORTE A-A

### 4614 KADÍ DOBLE DUO



empotrado  
con tapas 4613

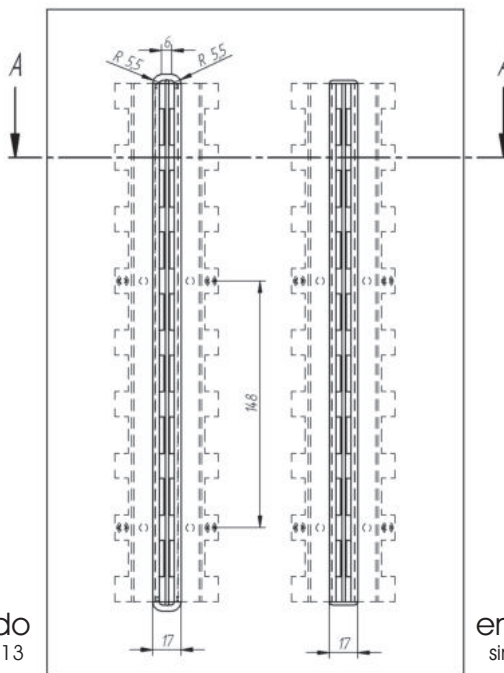

empotrado  
sin tapas 4613

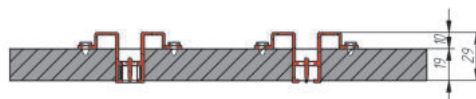

CORTE A-A

# KADÍ - CREMALLERAS

GUÍAS-CREMALLERA EN ALUMINIO - CRÉMAILLÈRES EN ALUMINIUM  
RACKS IN ALUMINIUM - PROFILI CREMAGLIERA IN ALLUMINIO

## KADÍ DUO 4615 y KADÍ DOBLE DUO 4614 PANELES COLGADOS A LAS CREMALLERAS

RACKS DUO 4615 AND DOBLE DUO 4614 PANEL HUNG TO THE RACK  
CRÉMAILLÈRES DUO 4615 AND DOBLE DUO 4614 PANNEAUX ACCROCHÉ A LE CRÉMAILLÈRE  
PROFILI CREMAGLIERA DUO 4615 E DOBLE DUO 4614 PANNELLO APPESO AL PROFILO

ref. 4615 - DUO

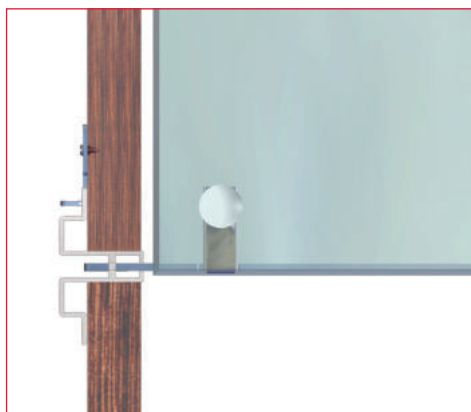

ref. 4614 - DOBLE DUO

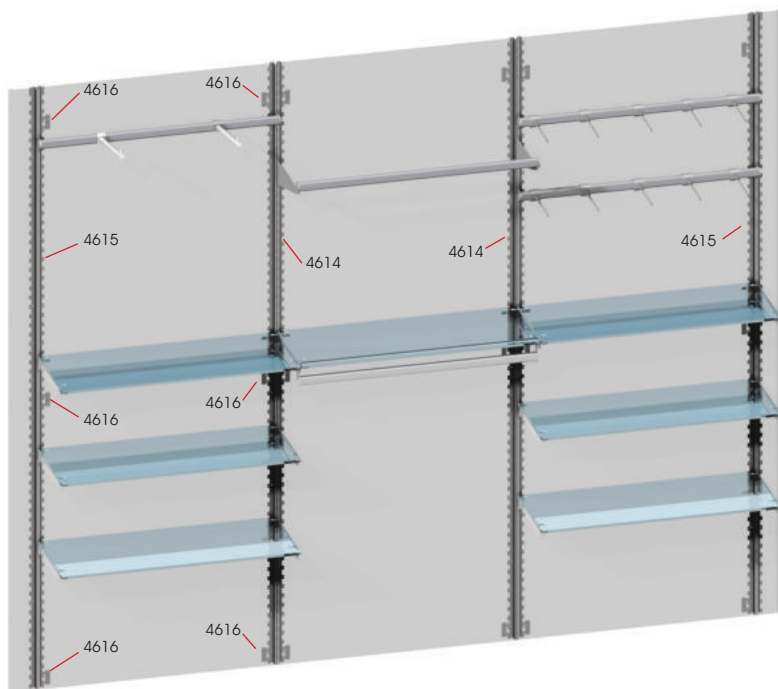
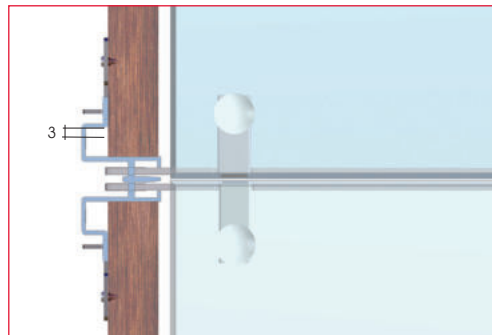

### colocación de los ganchos 4616 Y 4635

- el taladro central del gancho 4616 corresponde al paso de la cremallera: 37 mm.
- utilizar 4 ó 6 ganchos por panel dependiendo de su medida
- la distancia de los ganchos del borde del panel puede variar: se recomienda 36 mm.

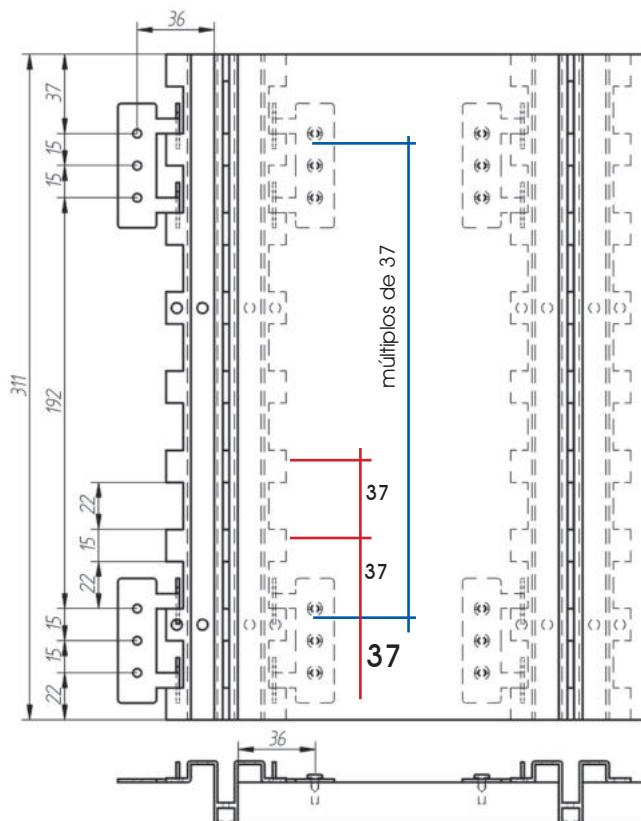
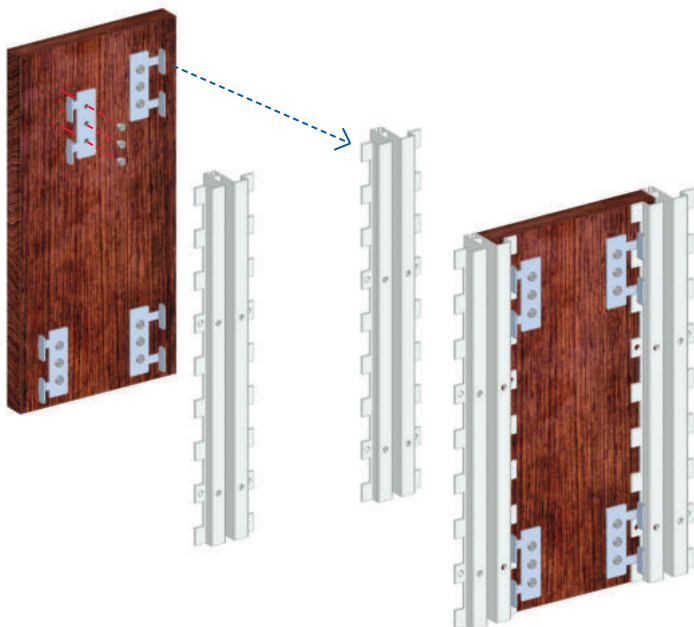



# KADÍ - EMPOTRABLE ALUMINIO

PL. M ALU. M ALL. M ALL. NAT	PL. BR ALU. BR ALL. LUC	BLANCO BLANC WHITE BANCO	NEGRO NOR BLACK NERO	COLOR COULEUR COLOR COLORE
01	02	0B	0N	0P

RAL 9006 = color OP  
metal. OM= 001+50%

# KADÍ - CLASSIC

GUÍAS-CREMALLERA - CRÉMAILLÈRES  
RACKS - PROFILI CREMAGLIERA

PL. BR ALU. BR ALL. LUC	PL. M ALU. M ALL. M ALL. NAT	BLANCO BLANC WHITE BANCO	NEGRO NOR BLACK NERO	COLOR COULEUR COLOR COLORE
02	01	0B	0N	0P

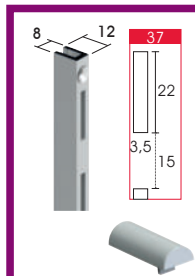

## GUÍA CREMALLERA EMPOTRABLE

GUIDE DE GRILLE ENCASTRÉ  
RECESSED RACK GUIDE  
GUIDA RACK AD INCASSO

4567/1.. 5m  
4567/102 2,5m

REMATE FINAL PARA 4567  
CABOCHON POUR 4567  
END-CAP FOR 4567  
COPRITESTA PER 4567  
84567/0..

Al	5 m	12x8	€/m
----	-----	------	-----

**NUEVO**

# KADÍ - COLUMNA

GUÍAS-CREMALLERA - CRÉMAILLÈRES  
RACKS - PROFILI CREMAGLIERA

PL. M ALU. M ALL. M ALL. NAT	BLANCO BLANC WHITE BANCO	NEGRO NOR BLACK NERO	COLOR COULEUR COLOR COLORE
01	0B	0N	0P

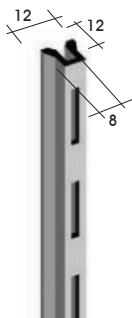

## GUÍA CREMALLERA COLUMNAS

CRÉMAILLÈRE COLONNE  
RACK FOR COLUMNS  
CREMAGLIERA COLONNE

4606/1..



Al	5 m	12x12	€/m
----	-----	-------	-----

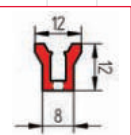

CR. BRILLO CHR. POLI BR. CHR CR. LUC.	32
--	----

Zn	90x30 mm	€/u
----	----------	-----

# KADÍ - \*VÉRTICE

CASQUILLO - INSERT VERTICAL  
VERTICAL SOCKET - BOCCOLA VERTICALE



CASQUILLO VERTICAL  
INSERT VERTICAL  
VERTICAL SOCKET  
BOCCOLA VERTICALE  
\*4699/0..

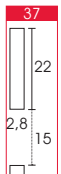

PL. M ALU. M ALL. M ALL. NAT	01
---------------------------------------	----

Al	2 m	∞ 4612	€/u
----	-----	--------	-----

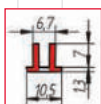

\*4611/2..

# KADÍ - MUEBLES

GUÍAS-CREMALLERA MUEBLES - CRÉMAILLÈRES MOBLES  
RACKS FOR FURNITURE - CREMAGLIERA MOBILI



GUÍA PARA EMPOTRAR  
CRÉMAILLÈRE POUR INCAISSÉ  
RACK TO BE EMBEDDED  
CREMAGLIERA DA INCASSO

Sólo con pestaña 4612  
NO COMPATIBLE CON EL SISTEMA KADÍ  
PAS COMPATIBLE AVEC LE SYSTEME KADÍ  
NOT COMPATIBLE WITH SYSTEM KADÍ  
NON COMPATIBILE CON SISTEMA KADÍ

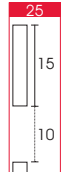

PL. M ALU. M ALL. M ALL. NAT	01
---------------------------------------	----

Al	2 m	∞ 4612	€/u
----	-----	--------	-----

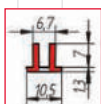

\*4611/2..

Paso cremallera 4611:  
15 abierto 10 cerrado.  
Pas crémaillère 4611:  
15 ouverte 10 fermée.  
Rack 4611 step:  
15 open 10 close  
Passo cremagliera 4611:  
15 aperto 10 chiuso.

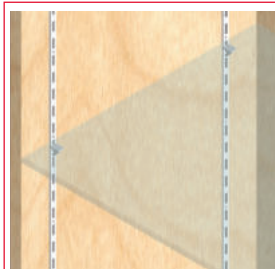

La 4611 se fija en los laterales del mueble y se usa solo con la pestaña 4612  
Le 4611 est fixé sur les côtés de l'armoire et est utilisé uniquement avec le taquet 4612.  
The 4611 is set at the sides of the cabinet and is used only with the tab 4612.  
La 4611 si incassa nei laterali dell'armadio e si usa solo con il supporto 4612.

Al	∞ 4611	€/u
----	--------	-----

APOYO ESTANTE  
TAQUET ÉTAGÈRE  
SHELF SUPPORT  
SUPPORTO MENSOLA  
\*4612/0..



## GUÍA PANELABLE 1 CANAL

CRÉMAILLÈRE SIMPLE PERFORATION  
RACK SINGLE CHANNEL  
CREMAGLIERA FORATURA SEMPLICE

4600/1.. 5m  
4600/142 2.5m

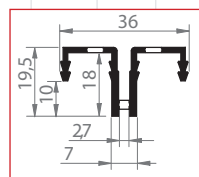
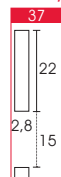

Al	2.5-5m	19,5x36	€/m
----	--------	---------	-----

## GUÍA FINAL PANELABLE 1 CANAL

CRÉMAILLÈRE FINALE SIMPLE PERFORATION  
FINAL RACK SINGLE CHANNEL  
CREMAGLIERA FINALE FORATURA SEMPLICE

4602/1.. 5m  
4602/142 2.5m

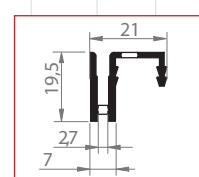
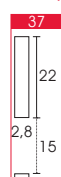

Al	2.5-5m	19,5x21	€/m
----	--------	---------	-----

## GUÍA PANELABLE 2 CANALES

CRÉMAILLÈRE DOUBLE PERFORATION  
RACK DOUBLE CHANNEL  
CREMAGLIERA FORATURA DOPPIA

4601/1.. 5m  
4601/142 2.5m

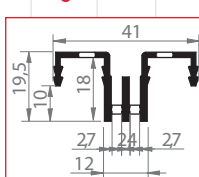
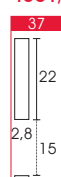

Al	2.5-5m	19,5x41	€/m
----	--------	---------	-----

## TAPA DE ALUMINIO

PROFIL À RECOUVREMENT  
COVER PROFILE  
PROFILO COPERTINA

4603/1..

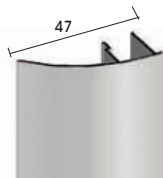

Al	5 m	19,5x47	€/m
----	-----	---------	-----

∞ 4600-4601-4602

Fe	∞ 4600-4603	€/u
----	-------------	-----

TAPA 4603+4600  
CABOCHON 4603+4600  
END-CAP 4603+4600  
COPRITESTA 4603+4600  
4604/0..

NOX SAT INOX SAT S.S.S. INOX SAT	28
---	----

Fe	∞ 4600-4601-4602	€/u
----	------------------	-----

GRAPA PARA COLGAR PANELES  
CROCHET POUR ACCROCHER PANNEAUX  
HOOK TO HANG WOOD PANELS  
GANCIO PER APPENDERE PANNELLI

4607/028



# BOTONES PLÁSTICO PARA PANELADO

BOTÓN IZQUIERDO  
CHROCHET GAUCHE  
DE MAINTIEN  
LEFT PANEL HOOK  
FERMAPANNELLO SINISTRO

4780/009

PLÁSTICO PLASTIQUE PLASTIC PLASTICA	plás	∞ CLASSIC-OMEGA-ALA	€/u
--	------	---------------------	-----

10 - 16 mm

09
----

BOTÓN DERECHA  
CHROCHET DROIT DE MAINTIEN  
RIGHT PANEL HOOK  
FERMAPANNELLO DESTRO

4781/009

BOTÓN CENTRAL.  
CHROCHET DOUBLE DE MAINTIEN  
DOUBLE PANEL HOOK  
FERMAPANNELLO DOPPIO

4782/009





# KADÍ - OMEGA

GUÍAS-CREMALLERA - CRÉMAILLÈRES  
RACKS - PROFILI CREMAGLIERA



POSIBILIDAD DE COLOCAR DIRECTAMENTE A PARED



POSIBILIDAD DE COLOCAR DIRECTAMENTE A PARED



POSIBILIDAD DE COLOCAR DIRECTAMENTE A PARED



# KADÍ - ALA

GUÍAS-CREMALLERA - CRÉMAILLÈRES  
RACKS - PROFILI CREMAGLIERA

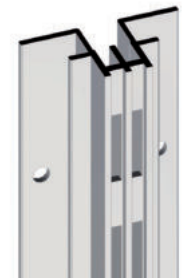

## OMEGA

GUÍA PANELABLE 1 CANAL  
CRÉMAILLÈRE SIMPLE PERFORATION  
RACK SINGLE CHANNEL  
CREMAGLIERA FORATURA SEMPLICE

4574/1..

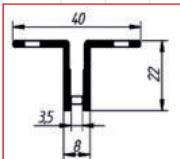
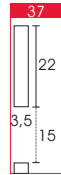

## OMEGA FINAL

GUÍA FINAL PANELABLE 1 CANAL  
CRÉMAILLÈRE FINALE SIMPLE PERFORATION  
FINAL RACK SINGLE CHANNEL  
CREMAGLIERA FINALE FORATURA SEMPLICE

4566/1..

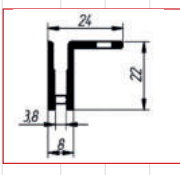
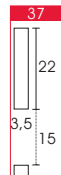

REMATE FINAL CABOCHON  
END-CAP COPRITESTA

4575/009 GRIS

## DOBLE OMEGA

GUÍA PANELABLE 2 CANALES  
CRÉMAILLÈRE DOUBLE PERFORATION  
RACK DOUBLE CHANNEL  
CREMAGLIERA FORATURA DOPPIA

4576/1..

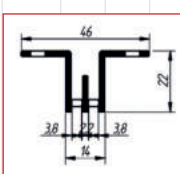
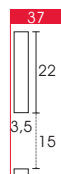

REMATE FINAL DOBLE CABOCHON DOUBLE  
DOUBLE END-CAP COPRITESTA DOPPIO

4577/009

PL. M	BLANCO	NEGRO	COLOR
ALU. M	BLANC	NOIR	COULEUR
ALU. M	WHITE	BLACK	COLOR
ALL. NAT	BIANCO	NERO	COLORE
01	0B	0N	0P
Al	5 m	40x24	€/m

plas	∞	4576	€/u
------	---	------	-----

Al	5 m	24x46	€/m
----	-----	-------	-----

plas	∞	4576	€/u
------	---	------	-----

## DOBLE ALA

GUÍA PANELABLE 2 CANALES  
CRÉMAILLÈRE DOUBLE PERFORATION  
RACK DOUBLE CHANNEL  
CREMAGLIERA FORATURA DOPPIA

4609/1.. doble

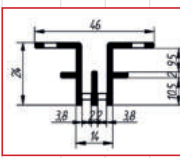
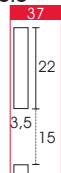

# KADÍ - DUO

GUÍAS-CREMALLERA - CRÉMAILLÈRES  
RACKS - PROFILI CREMAGLIERA

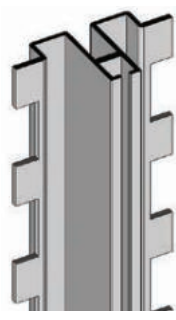

## DUO

GUÍA PANELABLE 1 CANAL  
CRÉMAILLÈRE SIMPLE PERFORATION  
RACK SINGLE CHANNEL  
CREMAGLIERA FORATURA SEMPLICE

4615/1..

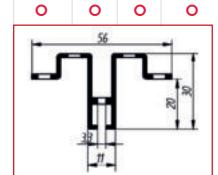

REMATE FINAL CABOCHON  
END-CAP COPRITESTA

4617/0..

## DOBLE DUO

GUÍA PANELABLE 2 CANALES  
CRÉMAILLÈRE DOUBLE PERFORATION  
RACK DOUBLE CHANNEL  
CREMAGLIERA FORATURA DOPPIA

4614/1..

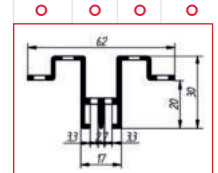
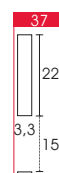

REMATE FINAL CABOCHON  
END-CAP COPRITESTA

4613/0..

GRAPA PARA COLGAR PANELES  
CROCHET POUR ACCROCHER PANNEAUX  
HOOK TO HANG WOOD PANELS  
GANCIO PER APPENDERE PANNELLI

4616/034

PARA MADERA DE GROSOR 19mm

4635/034

PARA MADERA DE GROSOR 10mm

ZINCADO PL. ZINK  
ZINK PL.  
ZINCATO

34

# KADÍ - HIERRO EMPOTRABLES

GUÍAS-CREMALLERA - CRÉMAILLÈRES  
RACKS - PROFILI CREMAGLIERA

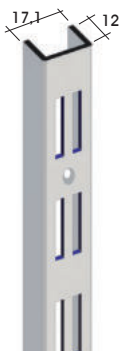

GUÍA EMPOTRABLE 1 CANAL  
CRÉMAILLÈRE SIMPLE PERFORATION  
RACK SINGLE CHANNEL  
CREMAGLIERA FORATURA SEMPLICE

4605/2..

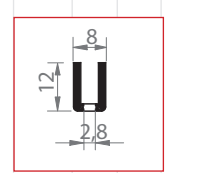

GUÍA EMPOTRABLE 2 CANALES  
CRÉMAILLÈRE DOUBLE PERFORATION  
RACK DOUBLE CHANNEL  
CREMAGLIERA FORATURA DOPPIA

\*4610/2..

POSIBILIDAD DE COLOCAR DIRECTAMENTE A PARED

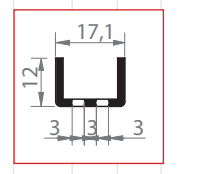

PL. M	BLANCO	NEGRO	COLOR
ALU. M	BLANC	NOIR	COULEUR
ALU. M	WHITE	BLACK	COLOR
ALL. NAT	BIANCO	NERO	COLORE
01	0B	0N	0P
Al	5 m	40x24	€/m

Fe	2.5m	8x12	€/u
----	------	------	-----

Al	5 m	24x46	€/m
----	-----	-------	-----

Fe	2.5m	17,1x12	€/u
----	------	---------	-----

# KADÍ - TUBULAR

ACCESORIOS - ACCESSOIRES  
FITTINGS - ACCESSORI

CR. BRILLO	PLÁSTICO	CR. MATE	BLANCO	NEGRO	COLOR
CR. POLI	PLASTIC	CR. M	BLANC	NOIR	COULEUR
CR. LUC.	PLASTICA	M. CHR	BLANCO	NERO	COLOR
		CR. OPAC	BIANCO	NERO	COLOR
32	09	31	0B	0N	0P

## CARTELAS "TUBULAR" - TUBO 30X10

**CARTELA ESTANTE VIDRO**  
SUPPORT TABLETTES VERRE  
GLASS SHELF BRACKET  
MENSOLA RIPIANO VETRO  
**4583/0.. 28 cm**



**CARTELA SUPPORT BRACKET MENSOLA**  
**4582/0.. 32 cm**



**VENTOSA TRANSPARENTE VENTOUSE SUCTION VENTOSA**  
**2556/009**



**PASADOR ESTANTE MADERA BROCHES À RESSORT PIN WOOD SHELF PERNO RIPIANO LEGNO**  
**358/000**

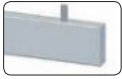

recortable  
recoupable  
shortened  
ritagliabile

**PERROQUET PLANO PENDERIE FRONTAL STRAIGHT ARM APPENDERIA FRONTALE**  
**4587/0.. 35 cm**



recortable  
recoupable  
shortened  
ritagliabile

**PERROQUET PLANO "T" PENDERIE LATERAL "T" LATERAL STRAIGHT ARM "T" APPENDERIA LATERALE "T"**  
**4588/0.. 35 cm**



**PERROQUET PLANO "Z" PENDERIE FRONTAL "Z" STRAIGHT ARM "Z" APPENDERIA FRONTALE "Z"**  
**4589/0.. 35 cm**



**CARTELA + BARRA PENDERIE SUPPORT + BARRE PENDERIE BRACKET + HANGING BAR MENSOLA + APPENDERIA**  
**4584/0.. 32 cm**



**CARTELA BARRA PENDERIE SUPPORT BARRE PENDERIE BRACKET HANGING BAR MENSOLA APPENDERIA**  
**4590/..**



**CARTELA BARRA ACCESORIOS SUPPORT BARRE ACCESSOIRES BRACKT FOR ACCESSORIES ROD MENSOLA TUBO PORTA-ACCESSORI**  
**4591/0..**



Fe	8-10 mm	200x292	€/u
----	---------	---------	-----

Recomendada con cremalleras DUO  
Recommandée avec crémaillères DUO  
Recommended with racks DUO  
Raccomandata con cremagliera DUO

Fe	∞ 2556-358	€/u
----	------------	-----

Ventosas y pasadores no incluidos  
Ventouses et broches NO INCLUS  
Suctions and pins not included  
Ventose e perni non inclusi

plas	∞ 4582-4583-4584	∅ 14	€/u
------	------------------	------	-----

Fe	∞ 4582-4583-4584	∅ 5x40	€/u
----	------------------	--------	-----

Fe	350 mm	€/u
----	--------	-----

Fe	350x600 mm	€/u
----	------------	-----

Fe	350 mm	€/u
----	--------	-----

Fe	∞ 4585(30x10)	320 mm	€/u
----	---------------	--------	-----

Ventosas y pasadores no incluidos  
Ventouses et broches NO INCLUS  
Suctions and pins not included  
Ventose e perni non inclusi

Fe	∞ 4585(30x10)	320 mm	€/u
----	---------------	--------	-----

Fe	∞ 4585(30x10)	60 mm	€/u
----	---------------	-------	-----

# KADÍ - TUBULAR

ACCESORIOS - ACCESSOIRES  
FITTINGS - ACCESSORI

CR. BRILLO	PL. M	CR. MATE	BLANCO	NEGRO	COLOR
CR. POLI	ALU. M	CR. M	BLANC	NOIR	COULEUR
CR. LUC.	ALU. M	M. CHR	BLANCO	NERO	COLOR
	ALL. NAT	CR. OPAC	BIANCO	NERO	COLOR
32	01	31	0B	0N	0P

## CARTELAS "PLANAS" - TUBO 30X10 HIERRO

**CARTELA BARRA PENDERIE SUPPORT BARRE PENDERIE BRACKET HANGING BAR MENSOLA APPENDERIA**  
30x10 mm (4585)



**4648/0..** derecha  
droite/right/dextra  
**4647/0..** izquierda  
gauche/left/sinistra

**CARTELA BARRA ACCESORIOS SUPPORT BARRE ACCESSOIRES BRACKT FOR ACCESSORIES ROD MENSOLA TUBO PORTA-ACCESSORI**

**4580/0..** derecha  
droite/right/dextra  
**4581/0..** izquierda  
gauche/left/sinistra

**TUBO RECTANGULAR TUBE RECTANGULAIRE RECTANGULAR TUBE TUBO RETTANGOLARE**  
**4585/1..**



**TAPA FINAL CON TOPE EMBOUT AVEC RÉTENTION END-CAP WITH STOP COPRIESTA + RETENZIONE**  
**4586/0..**



Fe	∞ 4585(30x10)	320 mm	€/u
----	---------------	--------	-----

Fe	∞ 4585(30x10)	€/u
----	---------------	-----

Fe	∞ 3 m	30x10x1,4	€/m
----	-------	-----------	-----

Fe	∞ 4585	40x10 mm	€/u
----	--------	----------	-----

## CARTELAS "PLANAS" - TUBO 30X10 ALUMINIO

NUEVO



**SET DE 2 CARTELAS LOT DE 2 SUPPORTS SET OF 2 BRACKETS SET DI 2 MENSOLE**  
**4866/0..**



**SET DE 2 CARTELAS LOT DE 2 SUPPORTS SET OF 2 BRACKETS SET DI 2 MENSOLE**  
**4868/0..**



**TUBO RECTANGULAR 30X10MM TUBE RECTANGULAIRE 30X10 RECTANGULAR TUBE 30X10 TUBO RETTANGOLARE 30X10**  
**4900/10.**



Incluye perfil de plástico superior.

**TAPA PARA TUBO 30X10MM CAPUCHON DE TUBE 30X10 TUBE CAP 30X10 TAPPO DEL TUBO 30X10**  
**4904/00.**



Para perfil 4900

Fe	?? mm	∞ 4900	€/u
----	-------	--------	-----

BL	NG	o	o
----	----	---	---

Fe	?? mm	∞ 4900	€/u
----	-------	--------	-----

BL	NG	o	o
----	----	---	---

Al	∞ 6 m	30x10	€/m
----	-------	-------	-----

∞ 84602

BL	NG	o	o
----	----	---	---

Fe	92 mm	∞ 4900	€/u
----	-------	--------	-----

BL	NG	o	o
----	----	---	---

## ACCESORIOS COMUNES 30X10

**PERROQUET PLANO PENDERIE FRONTAL STRAIGHT ARM APPENDERIA FRONTALE**  
**4592/0..**



**PERROQUET INCLINADO PERROQUET INCLINÉE SLOPING ARM APPENDERIA INCLINADA**  
**4593/0..**



**GANCHO CROCHET HOOK BARRETTA**  
**4594/0.. 20 cm**



**GANCHO PORTAPRECIO CROCHET PORTAPRIX HOOK LABEL-HOLDER BARRETTA PORTAPREZZO**  
**4597/0.. 25 cm**



**PORTAPRECIO PORTAPRIX LABELHOLDER PORTAPREZZO**  
**382/009**



Fe	∞ 4585	350 mm	€/u
----	--------	--------	-----

Fe	∞ 4585	400 mm	€/u
----	--------	--------	-----

Fe	∞ 4585	€/u
----	--------	-----

Fe	∞ 4585-382	€/u
----	------------	-----

plas	40x50 mm	€/u
------	----------	-----

PLÁSTICO  
PLASTIC  
PLASTICA  
09

# KADÍ - CARTELAS

ACCESORIOS - ACCESSOIRES  
FITTINGS - ACCESSORI

CR. BRILLO CHR. POLI BR. CHR. CR. LUC.	INOX INOX S.S.S.	SAT SAT SAT	CR. MATE CHR. M M. CHR. CR. OPAC.	BLANCO WHITE BIANCO	NEGRO BLACK NERO	COLOR COULEUR COLOR COLORE
32	28	31	0B	0N	0P	

## CARTELAS ESPECIALES "VIDRIO"

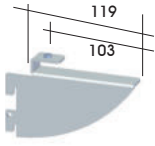

**CARTELA ESTANTE VIDRIO**  
SUPPORT TABLETTE VERRE  
GLASS SHELF BRACKET  
MENSOLA RIPIANO VETRO

4645/0.. derecha  
droite/right/destra

4646/0.. izquierda  
gauche/left/sinistra

Fe	8-10 mm	119 mm	€/u			

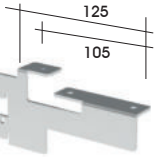

**CARTELA ESTANTE VIDRIO**  
SUPPORT TABLETTE VERRE  
GLASS SHELF BRACKET  
MENSOLA RIPIANO VETRO

4622/0.. derecha  
droite/right/destra

4623/0.. izquierda  
gauche/left/sinistra

Fe	8-10 mm	125 mm	€/u			

## CARTELAS ESPECIALES PARA PHARMA, CREMALLERA DUO Y ELECTRIFICADO. (APTO PARA TODOS LOS SISTEMAS KADÍ)



**CARTELA SUPPORT BRACKET MENSOLA**

5844/... derecha  
droite/right/destra

5845/... izquierda  
gauche/left/sinistra

5846/... doble  
double/double/doppio

Fe	8-10 mm	14,9 cm	€/u			

**! NUEVO**



SE RECOMIENDA ESTANTE DE VIDRIO TEMPLADO DE 30CM DE PROFUNDIDAD

**CARTELA FINAL ANTIVUELCO**  
SUPPORT FINAL ANTIBASCULAMENT  
FINAL BRACKET ANTITIPPING  
MENSOLA FINALE ANTIRIBALTAMENTO

\*4618/3..

Fe	8 mm		€/u			



SE RECOMIENDA ESTANTE DE VIDRIO TEMPLADO DE 30CM DE PROFUNDIDAD

**CARTELA INTERMEDIA ANTIVUELCO**  
SUPPORT INTERMÉDIAIRE ANTIBASCULAMENT  
INTERMEDIATE BRACKET ANTITIPPING  
MENSOLA INTERMEDIA ANTIRIBALTAMENTO

\*4619/3..

Fe	8 mm		€/u			

## CARTELAS ESPECIALES "MADERA"

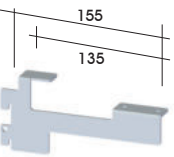

**CARTELA ESTANTE MADERA**  
SUPPORT TABLETTE BOIS  
WOOD SHELF BRACKET  
MENSOLA RIPIANO LEGNO

4620/0.. derecha  
droite/right/destra

4621/0.. izquierda  
gauche/left/sinistra

Fe	19 mm	155 mm	€/u			

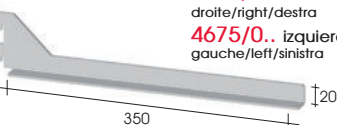

**CARTELA ESTANTE MADERA**  
SUPPORT TABLETTE BOIS  
WOOD SHELF BRACKET  
MENSOLA RIPIANO LEGNO

4676/0.. derecha  
droite/right/destra

4675/0.. izquierda  
gauche/left/sinistra

Fe	19 mm	350 mm	€/u			

# KADÍ - CARTELAS

ACCESORIOS - ACCESSOIRES  
FITTINGS - ACCESSORI

CR. BRILLO CHR. POLI BR. CHR. CR. LUC.	CR. MATE CHR. M M. CHR. CR. OPAC.	PLÁSTICO PLASTIQUE PLASTIC PLASTICA	BLANCO WHITE BIANCO	NEGRO BLACK NERO	COLOR COULEUR COLOR COLORE
32	31	09	0B	0N	0P

## "SILUETTE" PLEGADA PARA VIDRIO Y MADERA



**CARTELA SUPPORT BRACKET MENSOLA**

4692/0.. derecha  
droite/right/destra

4691/0.. izquierda  
gauche/left/sinistra

Fe	23 cm		€/u			



4694/0.. derecha  
droite/right/destra

4693/0.. izquierda  
gauche/left/sinistra

Fe	28 cm		€/u			



**VENTOSA TRANSPARENTE VENTOUSE SUCTION VENTOSA**

2556/009

plac	∞	4691-4692-4693-4694	∅ 14	€/u		

## CARTELAS "GRANDES PESOS" PARA VIDRIO Y MADERA



**CARTELA GRANDES PESOS SUPPORT GRAN POID BRACKET HEAVY WEIGHT MENSOLA GRANDI PESI**

4652/0.. derecha  
droite/right/destra

4653/0.. izquierda  
gauche/left/sinistra

Fe	35 cm		€/u			



**CARTELA INCLINADA 30° SUPPORT INCLINÉE 30° SLOPING BRACKET 30° MENSOLA INCLINATA 30°**

4632/0.. derecha  
droite/right/destra

4633/0.. izquierda  
gauche/left/sinistra

Fe	38 cm		€/u			



**CARTELA GRANDES PESOS SUPPORT GRAN POID BRACKET HEAVY WEIGHT MENSOLA GRANDI PESI**

4654/0.. derecha  
droite/right/destra

4655/0.. izquierda  
gauche/left/sinistra

Fe	42 cm		€/u			



**CARTELA GRANDES PESOS SUPPORT GRAN POID BRACKET HEAVY WEIGHT MENSOLA GRANDI PESI**

4656/0.. derecha  
droite/right/destra

4657/0.. izquierda  
gauche/left/sinistra

Fe	52 cm		€/u			



**VENTOSA TRANSPARENTE VENTOUSE SUCTION VENTOSA**

2556/009

plac	∞	4652-4653-4654-4655	∅ 14	€/u		



**CARTELA SUPPORT BRACKET MENSOLA**

\*4650/0.. derecha  
droite/right/destra

\*4651/0.. izquierda  
gauche/left/sinistra

Fe	30 cm		€/u			

profundidad del estante recomendada = 25-30 cm MAX.

La profundidad de estante recomendado para las cartelas suspendidas de la gama "CARTELAS ESPECIALES VIDRIO" es de 25-30 cm max. La profundidad del estante interfiere directamente en la capacidad y resistencia de aguante de las mismas cartelas y de todo el sistema.

# CAPACIDAD DE CARGA

Loading capacities - Capacités de chargement - Carichi massimi

## PESOS ORIENTATIVOS CARTELAS

		FONDO ESTANTE, DEEPTH SHELF, FOND DE TABLETTE, PROFONDITA RIPIANO					
		hasta 20 cm	hasta 25 cm	hasta 30 cm	hasta 35 cm	hasta 40 cm	hasta 50 cm
GANCHOS CARTELAS HOOKS BRACKETS CROCHET SUPPORTES GANCI MENSOLE	2 ganchos <small>Cartelas empotrables, siluette y tubulares.</small>	90 kg/est.	80 kg/est.	70 kg/est.	60 kg/est.		
	3 ganchos <small>Cartelas empotrables, siluette y tubulares.</small>			80 kg/est.	70 kg/est.	60 kg/est.	
	3 ganchos con pliego <small>Cartelas para grandes pesos.</small>				100 kg/est.	100 kg/est.	90 kg/est.
	2 ganchos con vidrio suspendido o con perfil tipo 362			30 kg/est.	20 kg/est.		

ALUSYSTEM recomienda el uso de vidrio templado para los estantes.

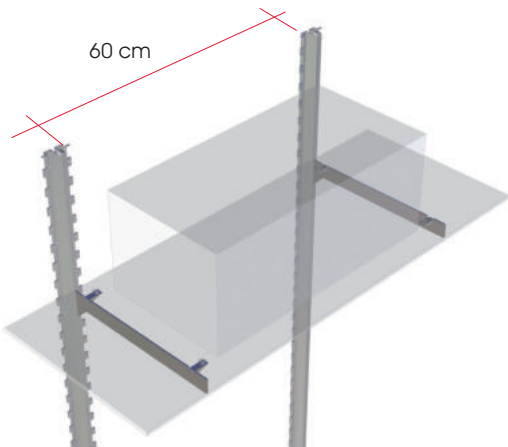

La resistencia de la cartela está determinada por:

1. el número de enganches a la cremallera (2 o 3),
2. la forma de la cartela (plegada más resistente)
3. el largo de la cartela (más corta más peso)

Cuanto más el baricentro del peso se coloca lejos de las guías, mayor es el esfuerzo que tiene que soportar la cartela.

Ejemplo: un peso de 20 kg a 30 cms de la cremallera corresponde a un peso de 40 kg a 15 cms o de 60 kg a 10 cms.

The strength of the bracket is determined by:

1. the number of hooks to the rack (2 or 3),
2. the shape of the bracket (folded more resistant)
3. the length of the bracket (shorter heavier)

The more the centroid of the weight is placed far from the guidelines, the greater the effort you have to put the bracket.

Example: the ability to withstand a weight of 20 kg to 30 cms of the slotted rack corresponds to a weight of 40 kg to 15 cms or 60 kg to 10 cms.

La force du support est déterminé par:

1. le nombre de crochets de la crémaillère (2 ou 3),
2. la forme de la console (pliée plus résistants)
3. la longueur de la console (plus lourde plus courte)

Le plus le centre de gravité de la masse est placée loin de les crémaillères, plus les efforts que doit supporter le support.

Exemple: la capacité à résister le poids de 20 kg à 30 cm de la crémaillère correspond à un poids de 40 kg à 15 cm ou de 60 kg à 10 cm.

La resistenza delle mensole è determinata da:

1. numero di ganchi per il profilo-cremagliera
2. forma delle mensole (le mensole piegate sono più resistenti)
3. la lunghezza delle mensole (più corte più resistenti)

Quanto maggiore è la distanza del baricentro dei carichi dai profili cremagliera tanto maggiore è lo sforzo che le mensole devono sopportare.

Esempio: la capacità di sopportare un peso di 20 kg a 30 cm dal profilo cremagliera corrisponde a 40 kg a 15 cm o di 60 kg a 10 cm.

## PESOS ORIENTATIVOS CREMALLERAS

Cremalleras DUO, Elektric, Omega, Ala y CR (4600 y 4601):

Con un peso de 100 kg repartido entre dos cremalleras no se han observado deformaciones importantes en las mismas.

Con un peso de 120 kg se ha detectado una deformación de 2/3° de la mismas.

No se han detectado roctura con más de 200 kg.

DUO, Elektric, Omega, Ala and CR (4600 and 4601) slotted racks:

With a weight of 100 kg divided between two racks no significant deformation was observed.

With a weight of 120 kg has been detected deformation 2/3°.

No breakage detected more than 200 kg.

Crémaillères DUO, Elektric, Omega, Ala et CR (4600 et 4601):

Avec un poids de 100 kg divisé entre deux racks pas de déformation significative n'a été observée.

Avec un poids de 120 kg a été détectée déformation de 3.2°.

Pas de rupture détecté plus de 200 kg.

Profili cremagliera DUO, Elektric, Omega, Ala e CR (4600 e 4601):

Con un carico di 100 kg ripartito fra due profili cremagliera non si osservano deformazioni importanti.

Con 120 kg si è registrata un'inclinazione del ripiano di 2/3°

Con più di 200 kg non si è arrivati alla rottura dei profili cremagliera.

### 1 estante

- peso distribuido encima del estante
- cremallera fijada a la pared (u otro soporte) en todos los puntos
- Pladur: **¡ATENCIÓN!** en caso de grandes pesos reforzar la pared o anclar a los montantes estructurales

1SELF 2 BRACKETS

- Weight distributed over the shelf

- Rack fixed to the wall (or other support) at all points

- Plasterboard: **ATTENTION!** for large weights to strengthen the wall metal structure and to anchor the racks to structural frames

1 TABLETTE 2 SUPPORTES

- Poids réparti sur le tablette

- Crémaillère fixée à la paroi (ou autre support) à tous les points

- Plaques de plâtre: **ATTENTION!** pour les grands poids de renforcer les montants structurelles du mur et fixées les crémaillères à la structure

1 RIPIANO 2 MENSOLE

- peso distribuito uniformemente sul ripiano

- profili cremagliera fissati alla parete (o ad altri tipi di supporto) in tutti i punti

Cartongesso: **ATTENZIONE!** in caso di grandi pesi, rinforzare le parete e fissare i profili cremagliera ai montanti strutturali

### 2 estantes + cartela intermedia

- **¡ATENCIÓN!** peso soportado por la cartela intermedia = suma del peso de los dos estantes dividido por 2

- **ATTENTION!** weight supported by intermediate gusset = sum of the weight of the two shelves divided by 2

- **ATTENTION!** poids supporté par intermédiaire gousset = somme des poids des deux plateaux divisés par 2

- **ATTENZIONE!** peso sopportato dalla mensola intermedia = somma del peso dei due ripiani divisi per 2

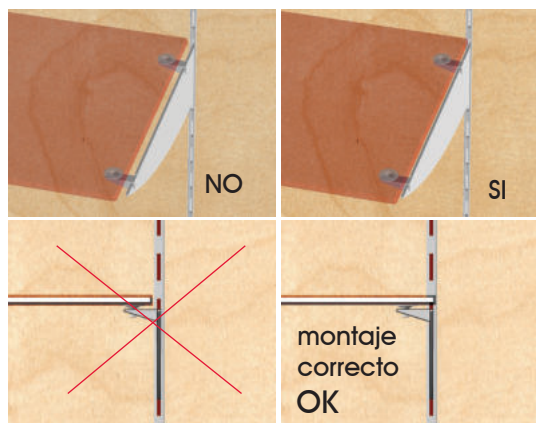
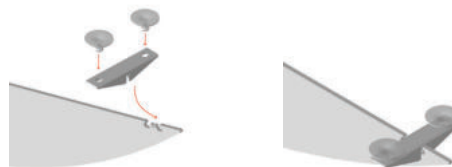





# KADÍ - CARTELAS

ACCESORIOS - ACCESSOIRES  
FITTINGS - ACCESSORI

CR. BRILLO	INOX	SAT	CR. MATE	BLANCO	NEGRO	COLOR
CR. POLI	INOX	SAT	CHR. M	BLANC	NOIR	COULEUR
CR. LUC.	S.S.S.		M. CHR	WHITE	BLACK	COLOR
	INOX	SAT	CR. OPAC	BIANCO	NERO	COLOR
32	28	31	0B	0N	0P	

## CARTELAS "EMPOTRABLE"







	Fe	∅ 4700-4701	€/U
 <b>CARTELA SUPPORT BRACKET MENSOLA</b> 4671			
 <b>4671/0.. 28 cm</b>	○		○
 <b>4672/0.. 33 cm</b>	○		○
 <b>4673/0.. 38 cm</b>	○		○

# KADÍ - CARTELAS

ACCESORIOS - ACCESSOIRES  
FITTINGS - ACCESSORI

CR. BRILLO	INOX	SAT	PLÁSTICO	BLANCO	NEGRO	COLOR
CR. POLI	INOX	SAT	PLASTIQUE	BLANC	NOIR	COULEUR
CR. LUC.	S.S.S.		PLASTIC	WHITE	BLACK	COLOR
	INOX	SAT	PLASTICA	BIANCO	NERO	COLOR
32	28	09	0B	0N	0P	



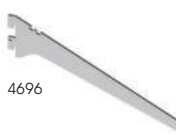

## CARTELAS "SILUETTE"

	Fe	∅ 4700-4701	€/U
 <b>CARTELA SUPPORT BRACKET MENSOLA</b> 4680			
 <b>4680/0.. 14cm</b>	○		○
 <b>4681/0.. 23cm</b>	○		○
 <b>4682/0.. 28cm</b>	○		○
 <b>4683/0.. 33cm</b>	○		○
 <b>4684/0.. 38cm</b>	○		○

## CARTELA "SILUETTE" INCLINADA

	Fe	∅ 4700-4701	€/U
 <b>CARTELA INCLINADA 30° SUPPORT INCLINÉE 30° SLOPPING BRACKET 30° MENSOLA INCLINATA 30°</b> 4696			
<b>4696/0.. 32cm</b>	○		○

## CABALLETES ESTANTES PARA CARTELAS

 <b>ALETA FINAL CAVALIER FINAL FINAL SADDLES CAVALIERE FINALE</b> 4700/0..	Fe	∅ 4702-319-2556	€/U
 <b>ALETA INTERMEDIA CAVALIER DOUBLE BOUBLE SADDLES CAVALIERE DOPPIO</b> 4701/0..	Fe	∅ 4702-319-2556	€/U
 <b>APOYO APPUI SUPPORT APPOGGIO</b> 4702/009	plas	∅9	∅ 4700-4701 €/U
 <b>VENTOSA VENTOUSE SUCTION VENTOSA</b> 319/009	plas	∅20	∅ 4700-4701 €/U
 <b>VENTOSA VENTOUSE SUCTION VENTOSA</b> 2556/009	plas	∅14	∅ 4700-4701 €/U

**CARTELA + BARRA PENDERIE SUPPORT + BARRE PENDERIE BRACKET + HANGING BAR MENSOLA + APPENDERIA**

5790 **5624/0.. derecha** ○ **5625/0.. izquierda** ○

droite/right/destra gauche/left/sinistra

**! NUEVO**

 <b>*4624/0.. derecha</b> *○ <b>*4625/0.. izquierda</b> *○					
 <b>4642/0.. 28 cm</b>				○	○
 <b>4643/0.. 28 cm</b>				○	○

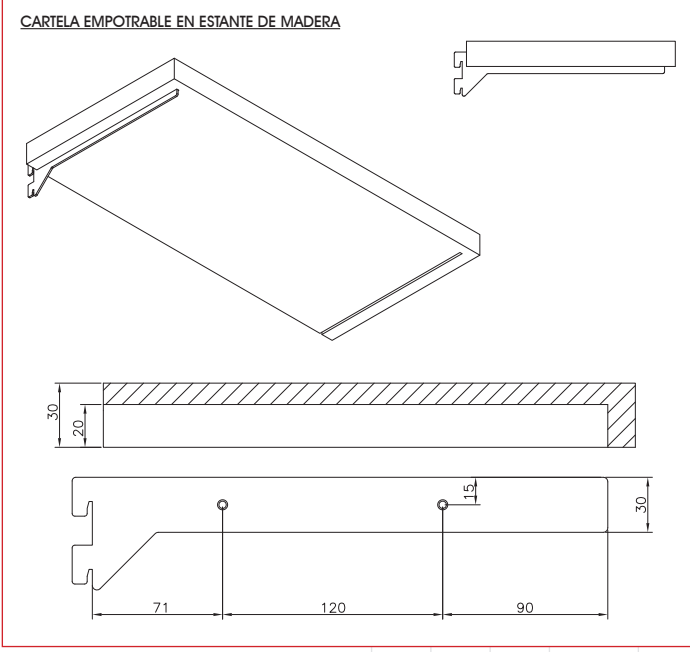

### CARTELA "SILUETTE" SUPPORTS "SILUETTE" "SILUETTE" BRACKETS SERIES MENSOLE "SILUETTE"



**CARTELA FINAL 4700**  
La aleta final 4700 sirven para mano derecha y mano izquierda  
**SUPPORT FINAL 4700**  
Le cavalier final 4700 peut être utilisé pour la main gauche et la main droite.  
**FINAL BRACKET 4700**  
The saddles 4700 can be used for left hand and right hand  
**MENSOLA FINALE 4700**  
Il Cavaliere 4700 si può usare a mano destra y a mano sinistra

estante madera = tornillos  
tablette en bois = vis  
wood shelf = screws  
ripiano di legno = viti

estante vidrio = ventosas  
tablette en bois = ventouses  
wood shelf = suctions  
ripiano di legno = ventose



**CARTELA INTERMEDIA**  
La aleta doble 4701 permite compartir 2 estantes con una sola cartela y una cremallera simple de un sólo troquel.  
**SUPPORT INTERMEDIAIRE**  
Le cavalier double 4701 vous permettent de partager 2 étagères avec un seul support et une crémaillère simple perforation.  
**INTERMEDIATE BRACKET**  
The double saddles allows you to share 2 shelves with a single bracket and a single slot rack.  
**MENSOLA INTERMEDIA**  
Il cavaliere doppio 4701 permette l'uso di 2 ripiani con una sola mensola e con una cremagliera con foratura semplice.

# KADÍ - CARTELAS

ACCESORIOS - ACCESSOIRES  
FITTINGS - ACCESSORI

CR. BRILLO	INOX SAT	CR. MATE	BLANCO	NEGRO	COLOR
CR. POLI	INOX SAT	CR. M	BLANC	NOR	COULEUR
BR. CHR	S.S.S.	M. CHR	WHITE	BLACK	COLOR
CR. LUC.	INOX SAT	CR. OPAC	BLANCO	NERO	COLOR
32	28	31	OB	ON	OP

## CARTELA PASANTE BARRA COLGADORA (36X18)

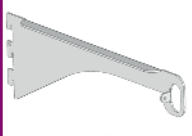
	Fe	32 cm	∞ 4547 (36x18)	€/u
				
CARTELA BARRA PENDERIE SUPPORT BARRE PENDERIE BRACKET HANGING BAR MENSOLA APPENDERIA				
<b>5628/0..</b> derecha	o		o	o
droite/right/destra				
<b>5629/0..</b> izquierda	o		o	o
gauche/left/sinistra				

**! NUEVO**

				
CARGA MEDIA - BAJA				
<b>*4628/0..</b> derecha	o		o	o
droite/right/destra				
<b>*4629/0..</b> izquierda	o		o	o
gauche/left/sinistra				

## CARTELA FINAL BARRA COLGADORA (36X18)

	Fe	32 cm	∞ 4547 (36x18)	€/u
CARTELA BARRA CUELGE SUPPORT DE BARRE DE SUSPENSION HANGING BAR BRACKET STAFFA PER BARRA SOSPESA				
<b>4790/0..</b> derecha	o		*o	o
droite/right/destra				
<b>4791/0..</b> izquierda	o		*o	o
gauche/left/sinistra				

	Fe	32 cm	∞ 4547 (36x18)	€/u
CARTELA BARRA CUELGE SUPPORT DE BARRE DE SUSPENSION HANGING BAR BRACKET STAFFA PER BARRA SOSPESA				
CARGA MEDIA - ALTA				
<b>4799/0..</b> intermedia	o		*o	o
inter./inter./inter.				

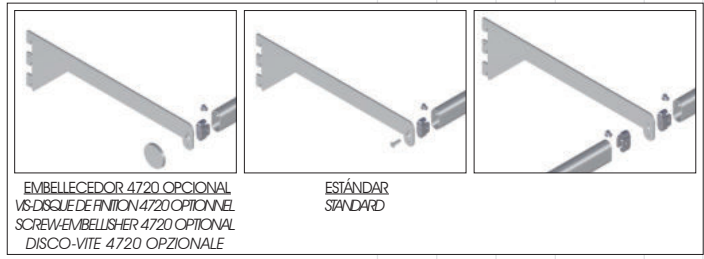

	Fe	32 cm	∞ 4547 (36x18)	€/u
CARTELA BARRA PENDERIE SUPPORT BARRE PENDERIE BRACKET HANGING BAR MENSOLA APPENDERIA				
<b>*4712/032</b> izquierda	*o			
gauche/left/sinistra				
<b>*4710/032</b> derecha	*o			
droite/right/destra				
<b>*4711/032</b> intermedia	*o			
inter./inter./inter.				

EMBELLECEDOR 4720 INCLUIDO  
VIS-DISQUE DE FINITION 4720 INCLUS  
SCREW-EMBELLSHER 4720 INCLUDED  
DISCO-VITE 4720 INLUSO

Tube 4547 for hanging bars and lighting system profile 4745  
Tube 4547 pour console penderie et profile éclairage 4745  
Tubo 4547 per appenderia e profilo illuminazione 4745

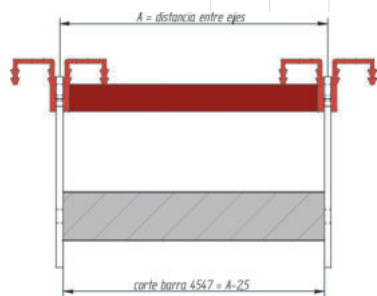

# KADÍ - CARTELAS

ACCESORIOS - ACCESSOIRES  
FITTINGS - ACCESSORI

CR. BRILLO	INOX SAT	CR. MATE	BLANCO	NEGRO	COLOR
CR. POLI	INOX SAT	CR. M	BLANC	NOR	COULEUR
BR. CHR	S.S.S.	M. CHR	WHITE	BLACK	COLOR
CR. LUC.	INOX SAT	CR. OPAC	BLANCO	NERO	COLOR
32	28	31	OB	ON	OP

## CARTELA PASANTE BARRA ACCESORIOS (36X18)

	Fe	∞ 4547(36x18)	43 mm	€/u
CARTELA BARRA ACCESORIOS SUPPORT BARRE ACCESSOIRES BRACKET FOR ACCESSORIES ROD MENSOLA TUBO PORTA-ACCESSORI				
<b>4626/0..</b>	o		*o	o

	Fe	∞ 4547(36x18)	67 mm	€/u
CARTELA BARRA ACCESORIOS SUPPORT BARRE ACCESSOIRES BRACKET FOR ACCESSORIES ROD MENSOLA TUBO PORTA-ACCESSORI				
<b>4627/0..</b>			o	o

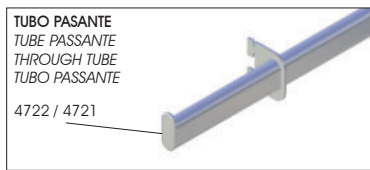

## CARTELA FINAL BARRA ACCESORIOS (36X18)

	Fe	60mm	∞ 4547 (36x18)	€/u
CARTELA BARRA ACCESORIOS SUPPORT BARRE ACCESSOIRES BRACKET FOR ACCESSORIES ROD MENSOLA TUBO PORTA-ACCESSORI				
<b>4716/0..</b> derecha	o		*o	o
droite/right/destra				
<b>4717/0..</b> izquierda	o		*o	o
gauche/left/sinistra				
<b>4715/0..</b> intermedia	o		*o	o
inter./inter./inter.				

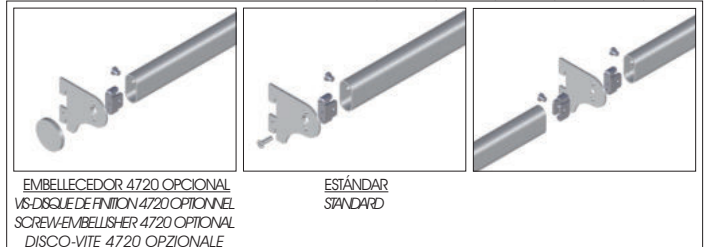



## TUBO OVALADO 36X18

	Fe	3 m	36x18x1,5	€/m
TUBO OVAL 36x18 mm TUBE OVALE 36X18 mm OVAL TUBE 36X18 mm TUBO OVALE 36X18 mm				
<b>4547/1..</b>	o		o	o

	Fe	∅38	∞ 4590-4591/4716-4717	€/u
TORNILLO-EMBELLECEDOR VIS-DISQUE DE FINITION SCREW-EMBELLSHER DISCO-VITE				
<b>4720/0..</b>	o		*o	o

SE ACONSEJA NO UTILIZAR CON CREMALLERAS DOBLE TROQUEL  
RECOMMANDÉ DE NE PAS UTILISER AVEC DES CRÉMAILLÈRES AVEC DOUBLE ERFORATION  
RECOMMENDED NOT TO USE WITH RACKS WITH DOUBLE SLOT CHANNEL  
NON RACCOMANDATO L'USO CON CREMAGLIERE CON FOIRATURA DOPPIA

	Fe	36x18	∞ 4547 (36x18)	€/u
TAPA FINAL EMBOUT END-CAP COPRITESTA				
<b>4721/032</b>	o			
	Zn	46x18	∞ 4547 (36x18)	€/u
TAPA FINAL CON TOPE EMBOUT AVEC RÉTENTION END-CAP WITH STOP COPRITESTA + RETENZIONE				
<b>4722/032</b>	o		*o	o

# KADÍ - CARTELAS

ACCESORIOS - ACCESSOIRES  
FITTINGS - ACCESSORI

CR. BRILLO	PLÁSTICO	CR. MATE	BLANCO	NEGRO	COLOR
CR. POLI	PLASTIQUE	CR. M	BLANC	NOIR	COULEUR
CR. LUC.	PLASTIC	M. CR	WHITE	BLACK	COLOR
	PLASTICA	CR. OPAC	BIANCO	NERO	COLORE
32	09	31	0B	0N	0P

## ACCESORIOS TUBO OVALADO 36X18

	<b>PERROQUET PLANO</b> PENDERIE FRONTAL STRAIGHT ARM APPENDERIA FRONTALE	Fe	∞ 4547	300 mm	€/u
	3019/0..	o		*o	o
	<b>PERROQUET INCLINADO</b> PERROQUET INCLINÉE SLOPING ARM APPENDERIA INCLINADA	Fe	∞ 4547	300 mm	€/u
	3022/0..	o		o	o
	<b>GANCHO</b> CROCHET HOOK BARRETTA	Fe	∞ 4547		€/u
	3014/0.. 25 cm	o		*o	o
	3020/0.. 20 cm	o		*o	o
	3021/0.. 10 cm	o		o	o
	<b>GANCHO PORTAPRECIO</b> CROCHET PORTAPRIX HOOK LABEL-HOLDER BARRETTA PORTAPREZZO	Fe	∞ 4547-382		€/u
	3012/0.. 25 cm	o		*o	o
	<b>PORTAPRECIO</b> PORTAPRIX LABEL-HOLDER PORTAPREZZO	plas	40x50 mm		€/u
	382/009		o		
	<b>BLOQUEO GANCHO</b> BLOCCAGE BROCHE HOOK SECURITY LOCK BLOCCO SICUREZZA GANCIO	plas		∅6 mm	€/u
	373/00N			o	
	<b>BLOQUEO GANCHO DOBLE</b> BLOCCAGE BROCHE DOUBLE DOUBLE HOOK SECURITY LOCK BLOCCO GANCIO DOPPIO	plas		∅6 mm	€/u
	383/00N			o	
	<b>IMÁN ESPECIAL DESBLOQUEO</b> UNLOCK MAGNET UNLOCK MAGNET MAGNETE DI SBLOCCO	plas		373-383/00N	€/u
	384/000			o	

## TUBO OVALADO 30X15

	<b>TUBO OVAL 30x15 mm</b> TUBE OVALE 30X15 mm OVAL TUBE 30X15 mm TUBO OVALE 30X15 mm	Fe	∞ 3 m	30x15x1,5	€/m
	4639/132 100 cm	o			
	<b>TAPA FINAL</b> EMBOUT END-CAP	plas	∞ 4639 (30x15)		€/u
	4640/0..	o		NEGRO	o
	<b>SOPORTE SUPERIOR</b> SUPPORT TUBE HAUTE UPPER TUBE SUPPORT SUPPORTO TUBO ALTO	Zn	∞ 4639 (30x15)		€/u
	1400/032	o			
	<b>SOPORTE LATERAL</b> SUPPORT TUBE LATERAL SIDE TUBE SUPPORT SUPPORTO TUBO LATERALE	Zn	∞ 4639 (30x15)		€/u
	4723/032	o			

# KADÍ - CARTELAS

ACCESORIOS - ACCESSOIRES  
FITTINGS - ACCESSORI

CR. BRILLO	INOX SAT	CR. MATE	BLANCO	NEGRO	COLOR
CR. POLI	INOX SAT	CR. M	BLANC	NOIR	COULEUR
CR. LUC.	S.S.S.	M. CR	WHITE	BLACK	COLOR
	INOX SAT	CR. OPAC	BIANCO	NERO	COLORE
32	28	31	0B	0N	0P

## PERROQUETES

	<b>PERROQUET PLANO</b> PENDERIE FRONTAL STRAIGHT ARM APPENDERIA FRONTALE	Fe	∞ NO "DUO"	∅16 330 mm	€/u
	4705/032	o			
	Sólo cremalleras DUO	Fe	∞ 4614-4615	∅16 330 mm	€/u
	4705/D32	o			
	<b>PERROQUET INCLINADO</b> PERROQUET INCLINÉE SLOPING ARM APPENDERIA INCLINADA	Fe	∞ NO "DUO"	∅16 330 mm	€/u
	4706/032	o			
	Sólo cremalleras DUO	Fe	∞ 4614-4615	∅16 330 mm	€/u
	4706/D32	o			
	<b>PERROQUET PLANO "T"</b> PENDERIE LATERAL "T" LATERAL STRAIGHT ARM "T" APPENDERIA LATERALE "T"	Fe	∞ NO "DUO"	∅25 300X400	€/u
	4708/032	o			
	Sólo cremalleras DUO	Fe	∞ 4614-4615	∅25 300X400	€/u
	4708/D32	o			
	<b>PERROQUET PLANO</b> PENDERIE FRONTAL STRAIGHT ARM APPENDERIA FRONTALE	Fe	∞ NO "DUO"	∅25	€/u
	*4713/0.. 30 cm	o			
	*4714/0.. 20 cm	o			

## SISTEMA PARA CUELQUE DE MUEBLES

	<b>CARTELA MUEBLES</b> SUPPORT POUR MOBILE FURNITURE BRACKET MESNOLA PER MOBILI	Fe	∞ 4600-4601-4602 / 4608-4609 / 4566-4574-4576		€/u
	4730/034			ZINCADO PL. ZINK ZINK PL. ZINCATO	34 o
	<b>CARTELA MUEBLES</b> SUPPORT POUR MOBILE FURNITURE BRACKET MESNOLA PER MOBILI	Fe	∞ 4614-4615		€/u
	4732/034				o
	<b>CARTELA MUEBLES</b> SUPPORT POUR MOBILE FURNITURE BRACKET MESNOLA PER MOBILI	Fe	∞ 4814-4815-4816		€/u
	4733/032	o			

# NUEVO PERFIL 362 PARA SISTEMA KADÍ Y LAMAS

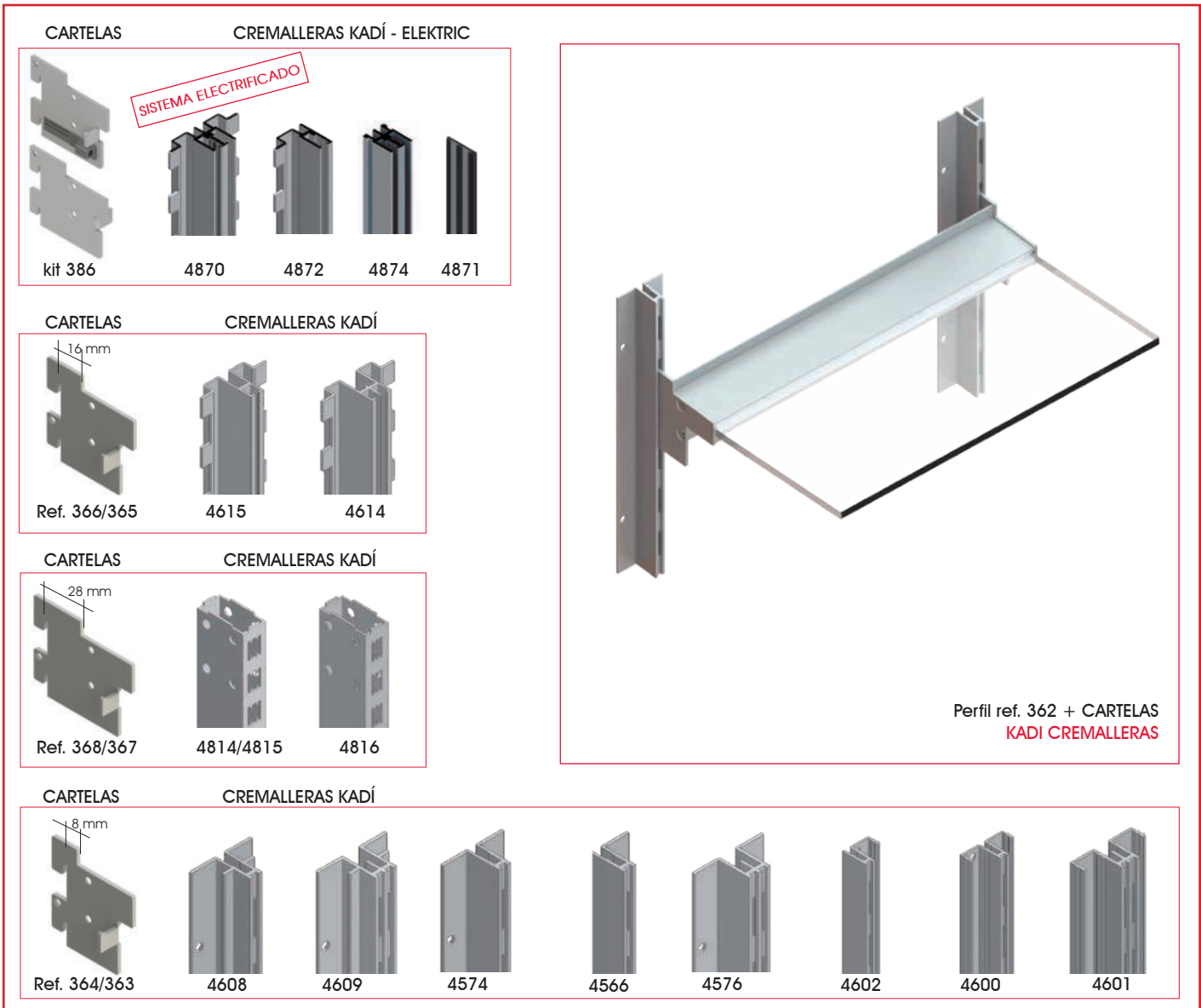
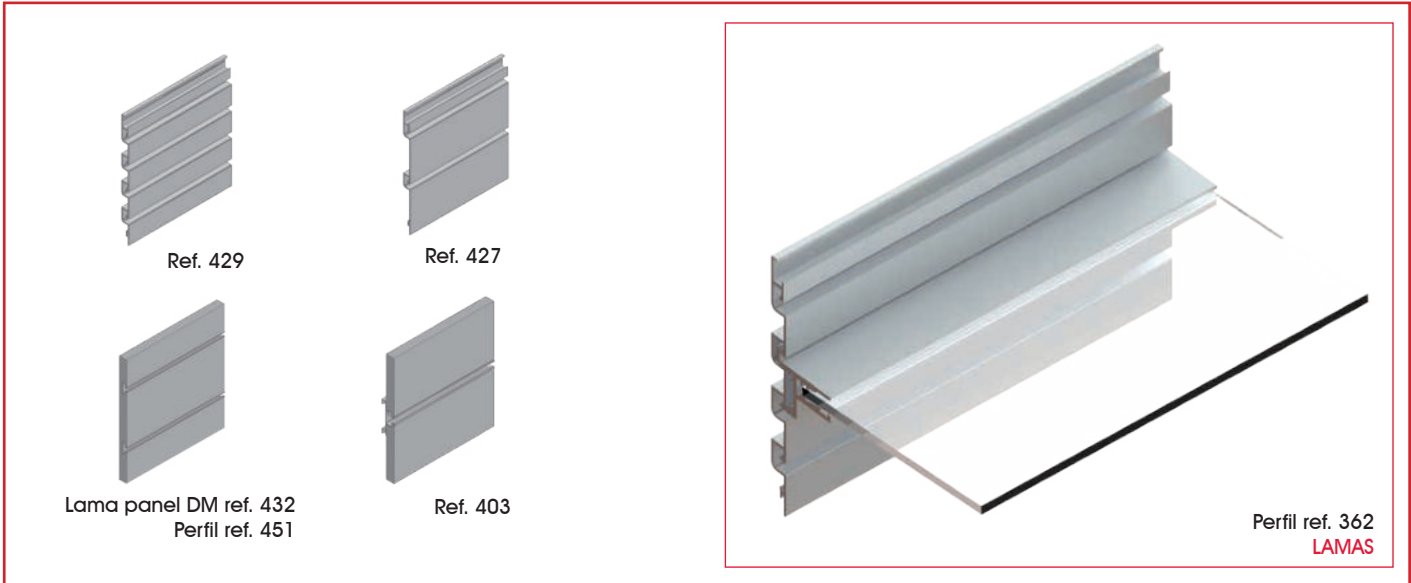

## Perfil aluminio 362

- Admite estante de vidrio de 6 y 8 mm.  
(SE RECOMIENDA VIDRIO DE SEGURIDAD).  
- Admite iluminación LED en el canal del perfil.

Aluminum profile, 362  
- Allows glass shelf 6 and 8 mm thickness.  
(SAFETY GLASS IS RECOMMENDED)  
- Allows LED lighting.

Profil en aluminium 362  
- Permet étagère en verre de 6 et 8 mm d'épaisseur  
(Verre de sécurité est recommandé)  
- Permet l'éclairage LED

Profilo in alluminio, 362  
- Ammette ripiani in vetro di 6 e 8 mm.  
(Si raccomanda l'uso di vetro securizzato)  
- Ammette LEDs.



**PERFIL - 362**

**PERFIL - 362**

PL. M	BLANCO	NEGRO	COLOR
ALU. M	BLANC	NOIR	COULEUR
ALU. M	WHITE	BLACK	COLOR
ALL. NAT	BIANCO	NERO	COLORE
01	0B	0N	0P
Al	6-8 mm	L	5 m
∞ 361/109			

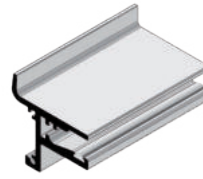
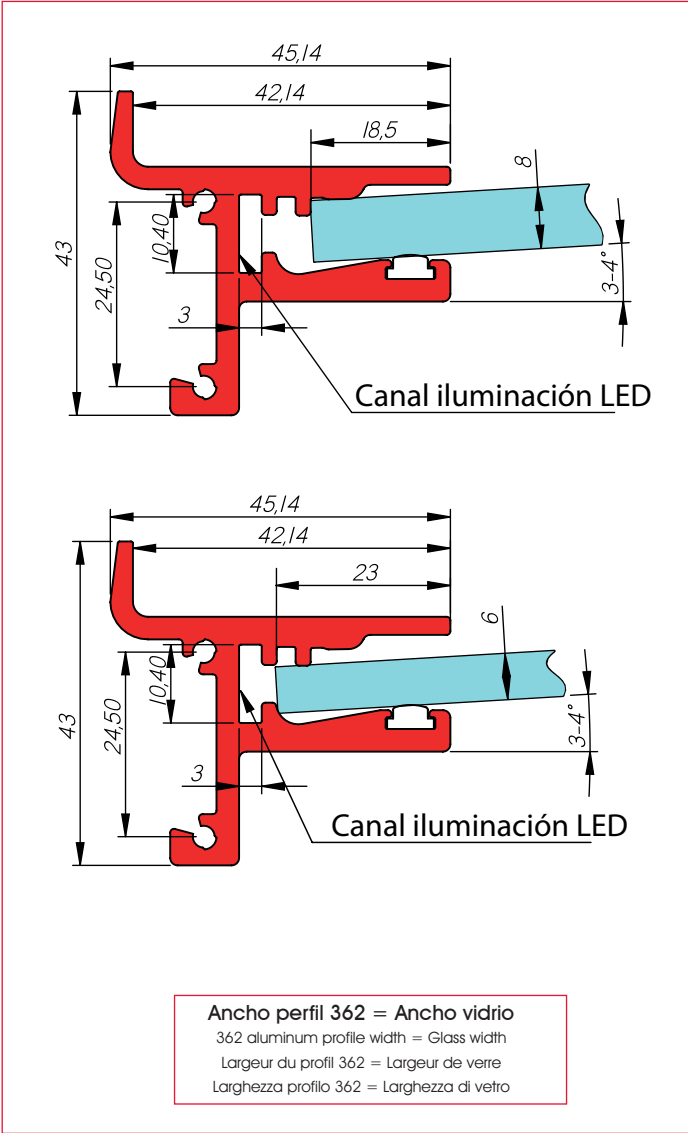

Junta goma incluida  
joint en caoutchouc inclus  
rubber gasket included  
giunta di gomma inclusa

PERFIL ALUMINIO.  
PROFIL LAME D'ALUMINIUM  
ALUMINIUM SLATWALL PROFILE  
PROFILO DOGATO ALLUMINIO  
**362/1..**

BLANCO	NEGRO	COLOR
BLANC	NOIR	COULEUR
WHITE	BLACK	COLOR
BIANCO	NERO	COLORE
0B	0N	0P
Fe	∞ 362	€/u

**KADÍ - CARTELAS**



CARTELA OMEGA / ALA / CLASSIC  
SUPPORT OMEGA / ALA / CLASSIC  
OMEGA / ALA / CLASSIC BRACKET  
MENSOLA OMEGA / ALA  
**364/0..** derecha  
droite/right/destra  
**363/0..** izquierda  
gauche/left/sinistra

CARGA MEDIA - BAJA



CARTELA DUO  
SUPPORT DUO  
DUO BRACKET  
MENSOLA DUO  
**366/0..** derecha  
droite/right/destra  
**365/0..** izquierda  
gauche/left/sinistra

CARGA MEDIA - BAJA

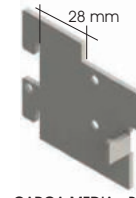

CARTELA PHARMA / PHARMA DUO  
SUPPORT PHARMA / PHARMA DUO  
PHARMA / PHARMA DUO BRACKET  
MENSOLA PHARMA / PHARMA DUO  
**368/0..** derecha  
droite/right/destra  
**367/0..** izquierda  
gauche/left/sinistra

CARGA MEDIA - BAJA

- Peso max. admitido según tipo de montaje, naturaleza del soporte (pared o mueble), vidrio y número de tornillos de fijación.
  - La inclinación del estante puede variar según la carga.
  - **Máxima carga para estante vidrio: 25 kg/ml.**
  - **Máxima medida estante recomendada: 100 x 30 cm.**
- Max. admitted weight depending on assembly type, on nature of the support (wall or furniture), glass and number of screws used.
- Allows LED lighting.
  - The shelf inclination may vary depending on the load.
  - **Máx. weight for shelf glass shelf: 50 kg / ml.**
  - **Maximum recommended shelf size: 100 x 30 cm.**
- Max. poids admis en fonction du type de montage, la nature du support (mur ou un meuble), le verre et le nombre de vis utilisées.
- Permet l'éclairage LED.
  - L'inclinaison de l'étagère peut varier en fonction de la charge.
  - **Poids maximum pour étagère en verre: 50 kg / ml.**
  - **Taille maximale de l'étagère recommandée: 100 x 30 cm.**
- Peso massimo ammesso a seconda del tipo di montaggio, del tipo di supporto (parete o mobile), vetro o legno e del numero di viti di fissaggio.
- Ammette LEDs.
  - L'inclinazione del ripiano può variare a seconda del peso.
  - **Peso massimo de ripiano di vetro: 50 kg/ml.**
  - **Dimensione massima raccomandata dello scaffale: 100 x 30 cm.**



# KADÍ - COLUMNAS

COLUMNAS EN ALUMINIO - COLONNE EN ALUMINIUM  
COLUMNS IN ALUMINIUM - COLONNE IN ALLUMINIO

PL. M	BLANCO	NEGRO	COLOR
ALU. M	BLANC	NOR	COULEUR
ALU. M	WHITE	BLACK	COLOR
ALL. NAT	BIANCO	NERO	COLORE
01	0B	0N	0P

## VERONA

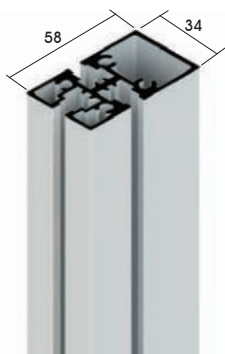

PERFIL ALUMINIO 3 CANALES  
PROFIL EN ALUMINIUM 3 FENTES  
ALUMINIUM PROFIL 3 SLOTS  
PROFILO D'ALLUMINIO 3 CANALI  
4520/1..

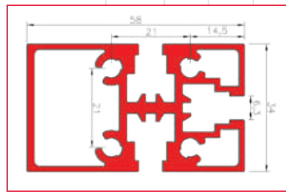

Al	6 m	∞	4606	€/m
----	-----	---	------	-----

--	--	--	--	--

TAPA EMBELLECEDORA  
EMBOUT  
END-CAP  
COPRITESTA  
4521/0..

Fe	∞	4520	€/u
----	---	------	-----

BASE FIJACIÓN SUELO  
BASE FIXATION SOL  
BASE  
BASE FISSAGGIO SUOLO  
4522/0..

Fe	∞	4520	€/u
----	---	------	-----

## BILBO

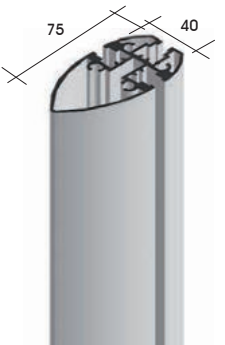

PERFIL ALUMINIO 3 CANALES  
PROFIL EN ALUMINIUM 3 FENTES  
ALUMINIUM PROFIL 3 SLOTS  
PROFILO D'ALLUMINIO 3 CANALI  
4510/1..

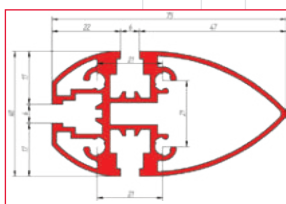

PRECIO COLOR = 9006

Al	6 m	∞	4606	€/m
----	-----	---	------	-----

--	--	--	--	--

TAPA EMBELLECEDORA  
EMBOUT  
END-CAP  
COPRITESTA  
4511/0..

Fe	∞	4510	€/u
----	---	------	-----

BASE FIJACIÓN SUELO  
BASE FIXATION SOL  
BASE  
BASE FISSAGGIO SUOLO  
4512/0..

Fe	∞	4510	€/u
----	---	------	-----

## MILAN

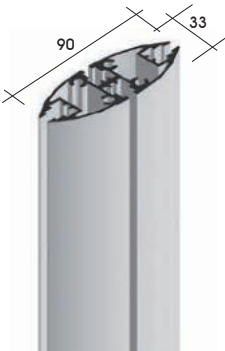

PERFIL ALUMINIO 3 CANALES  
PROFIL EN ALUMINIUM 3 FENTES  
ALUMINIUM PROFIL 3 SLOTS  
PROFILO D'ALLUMINIO 3 CANALI  
4505/1..

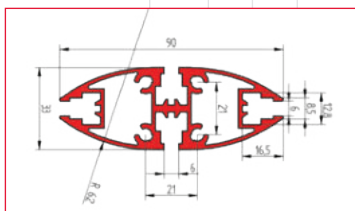

Al	6 m	∞	4606	€/m
----	-----	---	------	-----

--	--	--	--	--

TAPA EMBELLECEDORA  
EMBOUT  
END-CAP  
COPRITESTA  
4506/0..

Fe	∞	4505	€/u
----	---	------	-----

BASE FIJACIÓN SUELO  
BASE FIXATION SOL  
BASE  
BASE FISSAGGIO SUOLO  
4507/0..

Fe	∞	4505	€/u
----	---	------	-----

# KADÍ - COLUMNAS

COLUMNAS EN ALUMINIO - COLONNE EN ALUMINIUM  
COLUMNS IN ALUMINIUM - COLONNE IN ALLUMINIO

PL. M	BLANCO	NEGRO	COLOR
ALU. M	BLANC	NOR	COULEUR
ALU. M	WHITE	BLACK	COLOR
ALL. NAT	BIANCO	NERO	COLORE
01	0B	0N	0P

## CREMALLERA PARA COLUMNAS

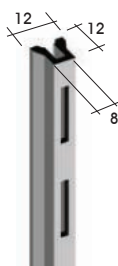

GUÍA CREMALLERA COLUMNAS  
CRÉMAILLÈRE COLONNE  
RACK FOR COLUMN  
CREMAGLIERA COLUMNES  
4606/1..

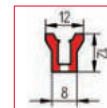

TORNILLO X GUÍA 4606  
VIS FIXATION PROFIL 4606  
SCREW x PROFIL 4606  
VITE FISSAGGIO PROFILO 4606  
4530/000

Al	5 m	12x12	€/m
	∞	4505-4510-4520	

--	--	--	--

TORNILLO ACCESORIOS  
VIS FIXATION ACCESSOIRES  
SCREW x ACCESSORIES  
VITE FISSAGGIO ACCESSORI  
4531/000

Fe	∞	4606	€/u
----	---	------	-----

Fe	∞	4522-4512-4507	€/u
----	---	----------------	-----

--	--	--	--

## MÓDULOS PARED CON COLUMNAS

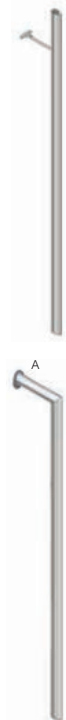

KIT PARED CON BRAZO TELESCÓPICO  
KIT MUR AVEC FIXATION TÉLESCOPIQUE  
KIT WALL WITH TELESCOPIC CONNECTION  
KIT PARETE CON FISSAGGIO TELESCOPICO

- 1 columnas hasta 3 m
- 2 cremalleras 2,5 m (4606/101)
- 1 tapas sup.
- 1 base inf.
- 1 brazo a pared (4545/032)
- 3 cortes

4572/M01	4505 Milán	○
4572/B01	4510 Bilbo	○
4572/V01	4520 Verona	○

KIT PARED CON INGLETE  
KIT MUR AVEC ONGLET  
KIT MUR WITH MITRE JOINT  
KIT A PARETE CON TAGLIO 45°

- 1 columna A+B max. = 3 m
- 2 cremalleras 2,5 m (4606/101)
- 1 base inf.
- 1 anclaje a pared (4544)
- 2 escuadras (4543)
- 4 cortes

4573/M01	4505 Milán	○
4573/B01	4510 Bilbo	○
4573/V01	4520 Verona	○

## GÓNDOLAS CON COLUMNAS



KIT GÓNDOLA 1º MÓDULO  
KIT GONDOLA 1ERE MODULE  
KIT 1ST GONDOLA MODUL  
KIT GONDOLA 1º MODULO

- 2 columnas 1,5 mt
- 4 cremalleras 1,5 mt 4606/101
- 2 tapas
- 4 pies 4559/032
- 2 traveseros 4535/101
- 4 grapas 4539
- 8 cortes

4570/M01	4505 Milán	○
4570/B01	4510 Bilbo	○
4570/V01	4520 Verona	○

KIT GÓNDOLA 2º MÓDULOS  
KIT GONDOLA 2EME MODULE  
KIT 1ND GONDOLA MODUL  
KIT GONDOLA 2º MODULO

- 1 columnas 1,5 mt
- 2 cremalleras 1,5 mt 4606/101
- 1 tapas
- 2 pies 4559/032
- 2 traveseros 4535
- 4 grapas 4539
- 5 cortes

4571/M01	4505 Milán	○
4571/B01	4510 Bilbo	○
4571/V01	4520 Verona	○

max.: 1,5 m - <-> 1 m
-----------------------

max.: 1,5 m - <-> 1 m
-----------------------

# KADÍ - COLUMNAS

COLUMNAS EN ALUMINIO - COLONNE EN ALUMINIUM  
COLUMNS IN ALUMINIUM - COLONNE IN ALLUMINIO

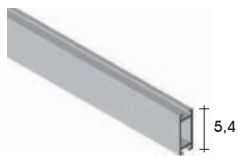

PERFIL TRAVESERO DOBLE CANAL  
PROFIL TRAVERSE DOUBLE FENTE  
PROFILE DOUBLE SLOT  
PROFILO TRAVERSA DOPPIA CANALE  
**4535/1..**



GALGA PARA GRAPAS 4539 Y 4540  
OUTIL POUR LES MONTAGE DES  
JOINTS 4539 ET 4540  
MOUNTING TOOL FOR THE JOINTS  
4539 AND 4540  
UTENSILE MONTAGGIO RACCORDI  
4539 E 4540  
**4538/000**



GRAPA UNIÓN 4535 CON COLUMNAS  
SIN CREMALLERA 4606  
JOINT DIRECTE 4535 AVEC COLONNES  
SANS CRÉMAILLÈRE 4606  
DIRECT JOINT 4535 WITH COLUMNS  
WITHOUT RACK 4606  
RACCORDO DIRETTO 4535 CON  
COLONNE SENZA CREMAGUERA 4606  
**4539/000**

## MONTAJE GRAPAS 4539 Y 4540 CON EL PERFIL 4535

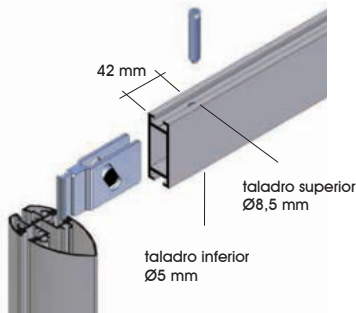

NIVELADOR SUPERIOR  
VÉRIN SUPÉRIEUR  
UPPER LEVEL  
LIVELLATORE SUPERIORE  
**4541/0..**



NIVELADOR INFERIOR  
VÉRIN INFÉRIEUR  
LOWER LEVEL  
LIVELLATORE INFERIORE  
**4542/0..**



ESCUADRA PARA INGLETE A 90°  
EQUERRE POUR JONCTIONS 90°  
FIXING JOINT 90°  
SQUADRA UNIONI A 90°  
**4543/034**



ENGANCHE A PARED  
PLAQUE DE FIXATION MURALE  
WALL PLATE CONNECTION  
PLACA FISSAGGIO A PARETE  
**4544/0..**

PL. M	BLANCO	NEGRO	COLOR
ALL. M	BLANC	NOIR	COULEUR
ALL. M	WHITE	BLACK	COLOR
ALL. NAT	BIANCO	NERO	COLORE
01	0B	0N	0P

Al	5 m	54x20	€/m
○	○	○	○
Fe	∞ 4535		€/u
○			
Fe	∞ 4535-4505-4510-4520		€/u
○			
Fe	∞ 4505-4510-4520		€/u
○		○	○
Fe	∞ 4505-4510-4520		€/u
○		○	○
Fe	∞ 4505-4510-4520		€/u
○			
Fe	∞ 4505-4510-4520		€/u
○			
Fe	∞ 4505-4510-4520		€/u
○			
Fe	∞ 4505-4510-4520		€/u
○		○	○

# KADÍ - COLUMNAS

COLUMNAS EN ALUMINIO - COLONNE EN ALUMINIUM  
COLUMNS IN ALUMINIUM - COLONNE IN ALLUMINIO

## COMPLEMENTOS "COLUMNAS"



BRAZO PARED TELESCÓPICO  
FIXATION TÉLESCOPIQUE MUR  
WALL TELESCOPIC CONNECTION  
FISSAGGIO TELESCOPICO A PARETE  
**4545/0..**

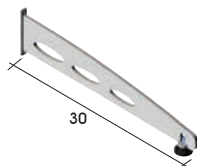

PIE GÓNDOLA O AUTOPORTANTE  
PIED GONDOLA OU AUTOPORTANT  
FOOT GONDOLA OR SELF-SUPPORTING  
PIEDE GONDOLA O AUTOPORTANTE  
**4559/0.. 30 cm**  
NIVELADOR INCLUIDO  
VÉRIN INCLUSO  
LEVEL INCLUDED  
LIVELLATORE INCLUSO



BASE REDONDA  
BASE CIRCULAIRE  
ROUND BASE  
BASE CIRCOLARE  
**4565/0..**

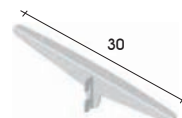

CARTELA CENTRAL  
SUPPORT CROCHET CENTRAL  
BRACKET WITH CENTRAL HOOK  
MENSOLA INCASTRO CENTRALE  
**4631/0.. 30 cm**



SOPORTE TUBO OVAL 4547  
SUPPORT TUBE PENDERIE 4547  
HANGING TUBE 4547 SUPPORT  
SUPPORTO TUBO APPENDERIA 4547  
**4546/0..**



TUBO OVAL 36x18 mm  
TUBE OVALE 36X18 mm  
OVAL TUBE 36X18 mm  
TUBO OVALE 36X18 mm  
**4547/1..**

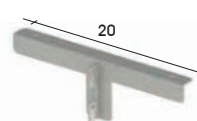

CARTELA CENTRAL  
SUPPORT CROCHET CENTRAL  
BRACKET WITH CENTRAL HOOK  
MENSOLA INCASTRO CENTRALE  
**4630/0..**



SOPORTE TUBO RECTANGULAR 4585  
SUPPORT TUBE RECTANGULAIRE 4585  
SUPPORT TUBE RECTANGULAR 4585  
SUPPORTO TUBO RETTANGOLARE 4585  
**4634/0..**



TUBO RECTANGULAR  
TUBE RECTANGULAIRE  
RECTANGULAR TUBE  
TUBO RETTANGOLARE  
**4585/1...**



PERROQUET PLANO  
PENDERIE FRONTAL  
STRAIGHT ARM  
APPENDERIA FRONTALE  
**4592/0..**



PERROQUET INCLINADO  
PENDERIE INCLINÉE  
SLOPING ARM  
APPENDERIA INCLINADA  
**4593/0..**

CR. BRILLO	BLANCO	NEGRO	COLOR
CR. POLI	BLANC	NOIR	COULEUR
BR. CHR	WHITE	BLACK	COLOR
CR. LUC.	BIANCO	NERO	COLORE
32	0B	0N	0P

Fe	∞ 4505-4510-4520	€/u
Fe	∞ 4505-4510-4520	M8 €/u
○		○
Fe	∞ 4505-4510-4520	∅395 €/u
○		○
Fe	∞ 4505-4510-4520+4606	€/u
○		○
Fe	∞ 4505-4510-4520+4606	€/u
○	∞ 4547 (36x18mm)	
○		○
Fe	∞ 3 m	36x18x1,5 €/m
○		○
Fe	∞ 4505-4510-4520+4606	€/u
Fe	∞ 4585	€/u
Fe	∞ 3 m	30x10x1,4 €/m
○		○
Fe	∞ 4585	350 mm €/u
○		○
Fe	∞ 4585	400 mm €/u
○		○

CR. MATE	CR. BRILLO	BLANCO	NEGRO	COLOR
CHR. M	CR. POLI	BLANC	NOIR	COULEUR
M. CHR	BR. CHR	WHITE	BLACK	COLOR
CR. OPAC	CR. LUC.	BIANCO	NERO	COLORE
31	32	0B	0N	0P

# KADÍ ELEKTRIC - PHARMA



## KADÍ ELEKTRIC - PHARMA



ESCANEA ESTE QR  
PARA VER TODAS  
LAS IMÁGENES DEL  
SISTEMA PHARMA



## KADÍ PHARMA ELEKTRIC

Ejemplos orientativos  
de distintas posibilidades,  
distribuciones y  
aplicaciones

# KADÍ ELEKTRIC - PHARMA

## EXPLOSIONADO GENERAL

### MONTAJE EN SERIE



Colocar las cremalleras ELECTRIFICADAS EN LADO DERECHO de cada panel

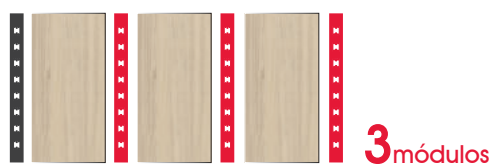

REF: 4786 + 4862 (CARRIL ELEKTRIC)

Tubos electrificados

Solo los orificios izquierdos (representados en rojo) están electrificados.

REF: 4786

Tubos sin carril eléctrico

**1** Cremallera electrificada 1 o 2 caras

1C REF: 4786 +4862

2C REF: 4787 +4863

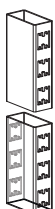

**2** Cremallera sin carril eléctrico 1 o 2 caras

1C REF: 4786  
2C REF: 4787

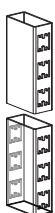

**3** Grapas para colgar paneles

2 posibles modelos:



**4** Tirantes



**5** Pies autoportantes



**6** Paneles (Propuesta de material)



**7** Accesorios

Personalizable:

- Estantes
- Barras
- Letreros

# KADÍ ELEKTRIC - PHARMA

## MONTAJE ELECTRICO

HASTA X6 PANELES ► X1

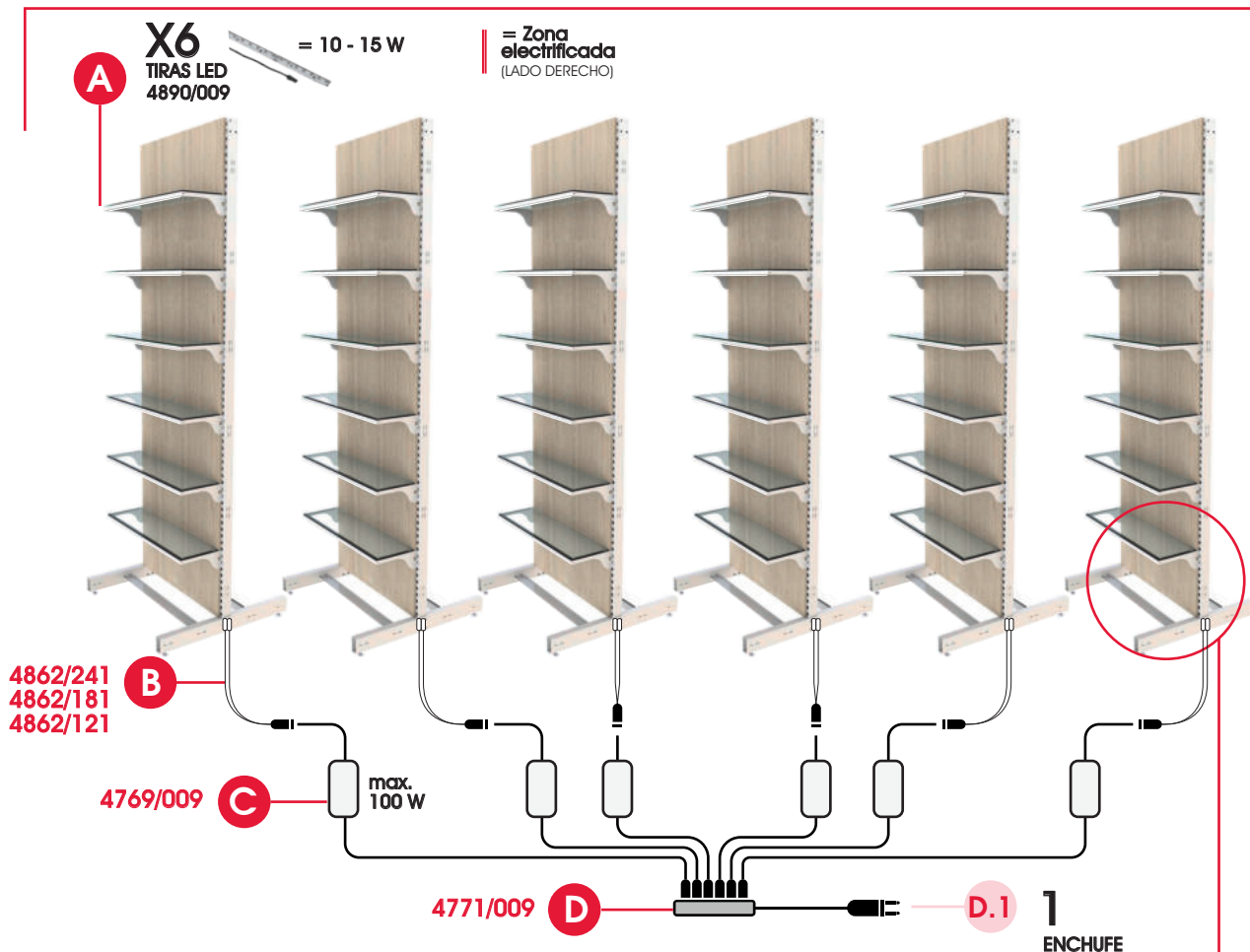

- A** Tiras LED (6 ud. por transformador)
- B** Cable con mini conector  
LONGITUD DEL CABLE - 1M
- C** Transformador (Cada panel debe llevar su transformador)
- D** Regleta de distribución
- D.1** Enchufe

- ES** • El carril electrificado lleva soldado el cable de conexión en la parte inferior. En el caso de prescindir de este conector Gesis, prestar atención a la polaridad de los cables para el correcto funcionamiento de la nueva conexión.
- FR** • La voie életrifiée porte le câble de connexion au conducteur en bas. En cas de suppression avec ce connecteur Gesis, faites attention à la polarité des câbles pour le bon fonctionnement de la nouvelle connexion.
- EN** • The electrified track carries the connection cable to the driver at the bottom. In the case of dispensing with this connector Gesis, pay attention to the polarity of the cables for the correct functioning of the new connection.
- IT** • Il binario elettrificato ha il cavo di connessione al driver saldato nella parte inferiore. Nel caso di prescindere del connettore Gesis, controllare la polarità dei cavi per assicurare il corretto funzionamento della nuova connessione.

Cualquier manipulación invalida la garantía del fabricante

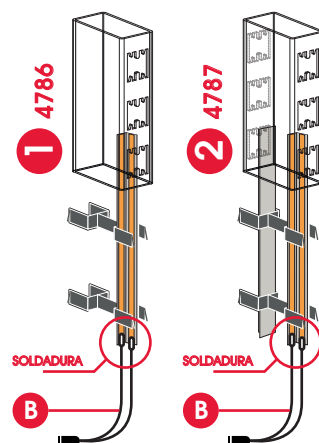

# KADÍ ELEKTRIC - PHARMA

## MONTAJE DE LOS PLAFONES A LAS CREMALLERAS

### CARACTERÍSTICAS DEL SISTEMA

- Compatible con la mayoría de accesorios del sistema Kadí
- Módulos de 512, 730 y 820 mm entre ejes de columna
- Posibilidad de regular altura de estantes independientemente.
- Sistema modular que permite la combinación de 3 soluciones:

### SYSTEM FEATURES

- Compatible with most Kadí system accessories
- Modules 512, 730 and 820 mm column between axes
- Possibility to adapt height of independent shelves
- Modular system that allows the combination of 3 solutions:

### CARATTERISTICHE DEL SISTEMA

- Compatibile con la maggior parte degli accessori del sistema Kadí
- Moduli di 512, 730 e 820 mm fra assi dei montanti
- Possibilità di altezza regolari di mensole indipendenti
- sistema modulare che permette la combinazione di 3 soluzioni:

### CARATTERISTICHE DU SYSTÈME

- Compatible avec la plupart des accessoires Kadí
- Modules de 512, 730 et 820 mm empattement colonne
- Possibilité de hauteur régulière des étagères indépendantes
- Système modulaire qui permet la combinaison de 3 solutions:

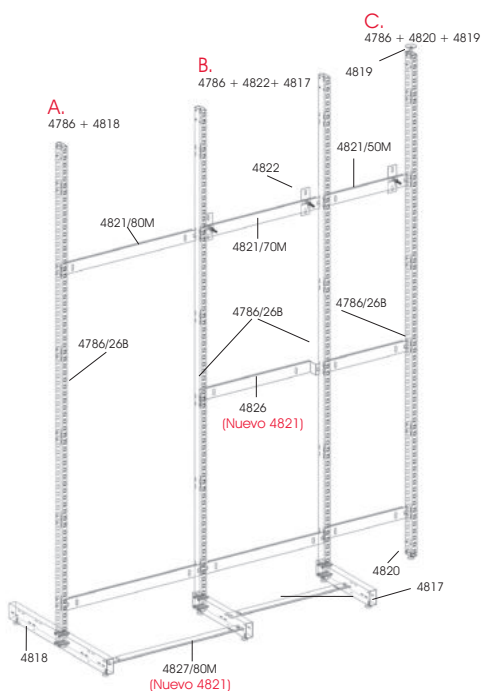

Solución GÓNDOLA  
Solution GONDOLA  
Solution GONDOLA  
soluzione GONDOLA

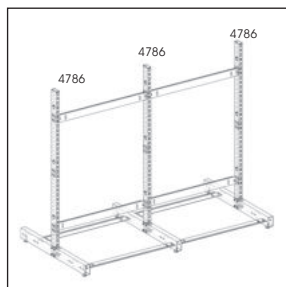

### Solución GÓNDOLA ó PARED DIVISORIA

Solution GONDOLA ou PARI SEPARATRICE  
Solution GONDOLA or PARTITION WALL  
soluzione GONDOLA o parete divisoria

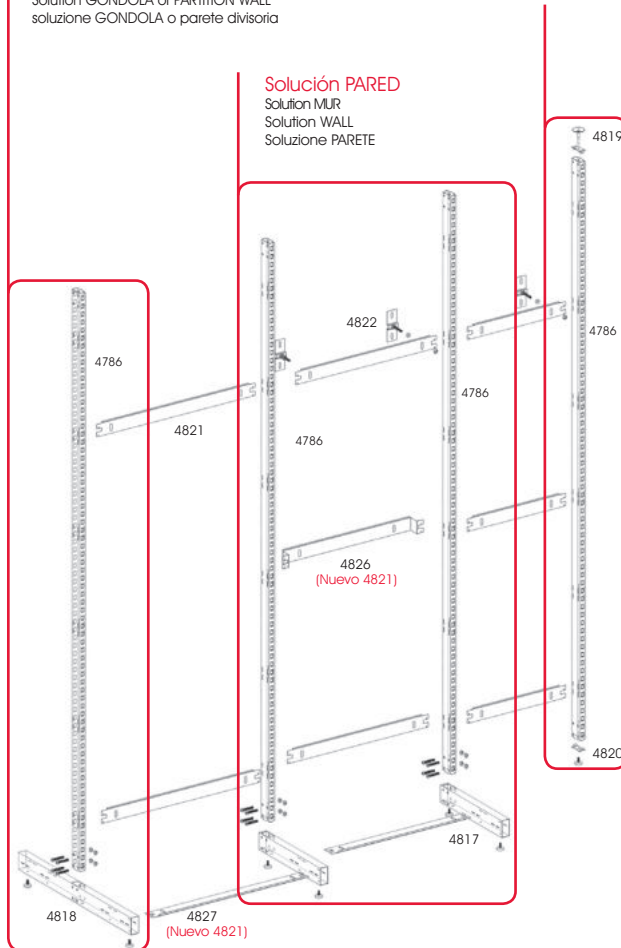

### Solución PARED

Solution MUR  
Solution WALL  
Soluzione PARETE

### Solución TECHO-SUELO

Solution SOL-PLAFOND  
Solution CEILING-FLOOR  
Soluzione SUOLO-SOFFITTO

### 4821 TIRANTES EN PLANO DIFERENTES

El uso de tirantes de unión en planos diferentes confiere más estabilidad a la góndola.

La utilisation de tirants dans de planes différents donne plus de stabilité à la gondole.

The use of rods spacer in different planes gives more stability to the gondola.

L'impiego di tiranti su piani differenti conferisce maggiore stabilità alla gondola.

### 4827 TIRANTE PARA PIES

NUEVOS TIRANTES 4821 (APTOS PARA PIES Y MONTANTES)

El uso de tirantes de unión en planos diferentes confiere más estabilidad a la góndola.

La utilisation de tirants dans la base donne plus de stabilité à la gondole.

The use of rods spacer in the base gives more stability to the gondola.

L'impiego di tiranti nella base conferisce maggiore stabilità alla gondola.



# KADÍ ELEKTRIC - PHARMA

## MEDIDAS PARA CORTE DE MADERA

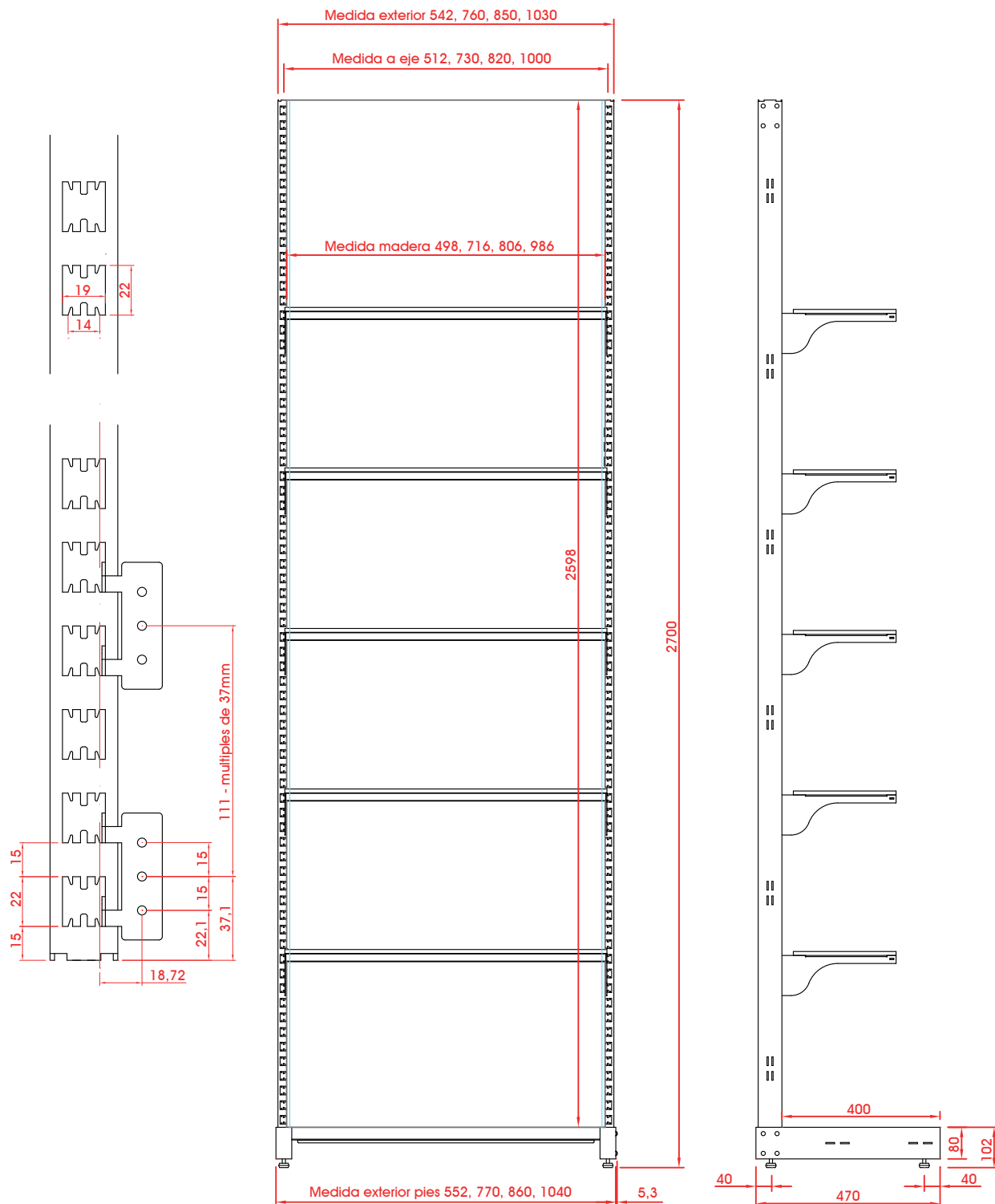

## KADÍ ELEKTRIC - PHARMA

## KADÍ PHARMA

Para paneles de máx. 16mm

Pour les panneaux max. 16mm

For max panels 16mm

Per pannelli massimi 16mm

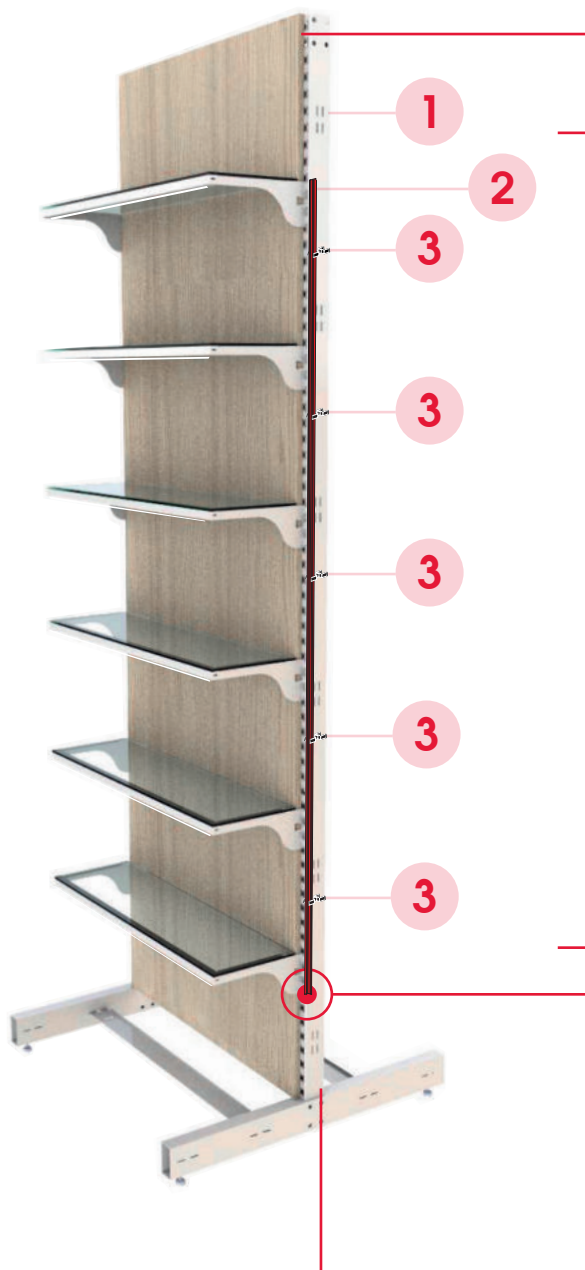

## 3 Grapas de plástico



- Las grapas deben ir repartidas de manera equitativa
- Colocar entre 4 y 8 grapas dependiendo de la medida.

- Tanto el tubo Pharma ( 1 ) como el carril electrificado ( 2 ) se pueden adaptar a cualquier medida. Posibilidad de cortar.

## INICIO DEL CARRIL ELECTRIFICADO

## 4 Tope inferior

El tope inferior puede colocarse en cualquier orificio de la cremallera

Creará el inicio del carril electrificado

El carril queda apoyado al tope

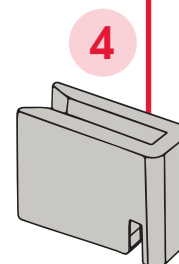
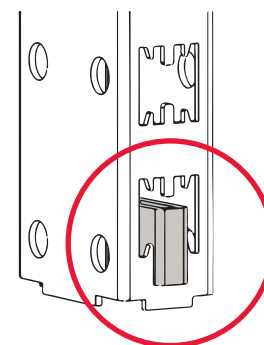

Orificio de salida del cable eléctrico por la parte trasera inferior del tubo.



# KADÍ ELEKTRIC - PHARMA

## TUBO PHARMA ELECTRIFICADO

**1** Tubo Pharma 60x30

**2** Carril eléctrico

**3** Grapas de plástico

**4** Tope inferior

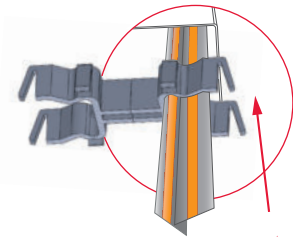

Insertar el carril eléctrico acorde con la dirección de grapas.

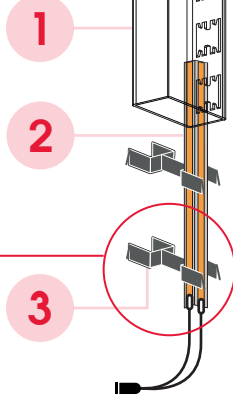

### CREMALLERA ELECTRIFICADA 1 CARA

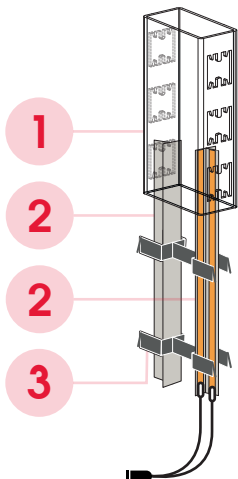
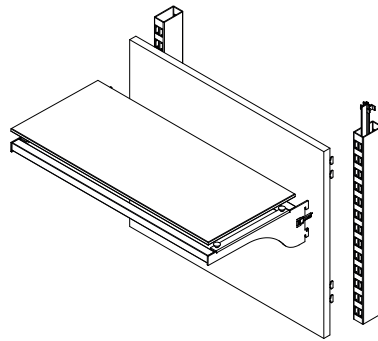

### CREMALLERA ELECTRIFICADA 2 CARAS

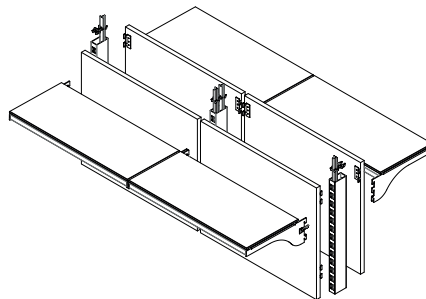

**5** Conector

COMPATIBLE KADÍ PRIMO



**6** Grapas de fijación para el conector



## COLOCACIÓN DEL CONECTOR

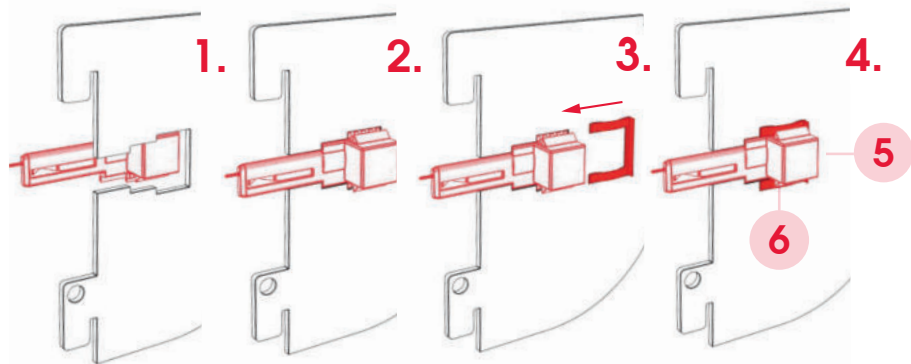

# KADÍ ELEKTRIC - PHARMA

## ACCESORIOS PHARMA

-  Vidrio
-  Madera
-  Diferentes materiales y acabados

### ESTANTES

#### CARGA LIGERA



6890..



NUEVO

6891..



NUEVO

#### CARGA MEDIA



#### CARGA ALTA



5894..



NUEVO

5896..



NUEVO

5895..



NUEVO

### BARRAS

#### CARGA LIGERA



#### CARGA MEDIA



5898..



NUEVO

5901..



NUEVO

5897..



NUEVO

### PORTA ROTULOS

#### CARGA LIGERA



5391



NUEVO

# KADÍ ELEKTRIC - PHARMA

## TABLA DE PESOS

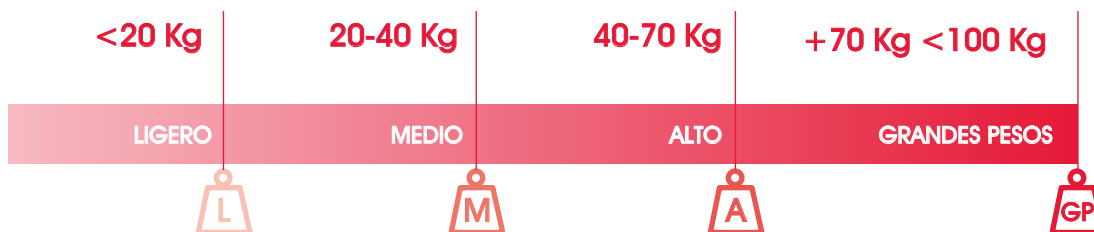

## COMPORTAMIENTO DE CARGA



\* La inclinación puede variar dependiendo del peso y la flexibilidad del aluminio.

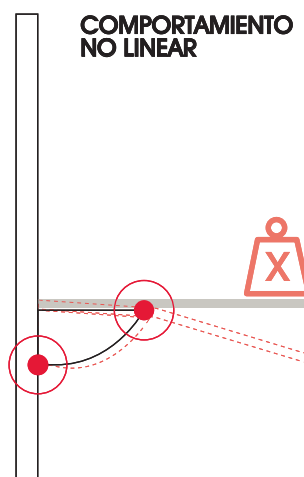
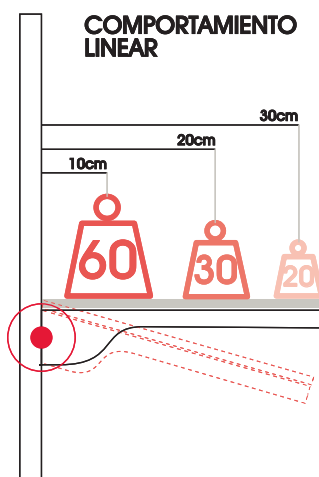

**AL ENCAJAR SE ENCIENDE**



## PLUG & PLAY

Con el sistema PLUG & PLAY el montaje de los módulos de carga resulta fácil, rápido y muy práctico, ya que solo encajando las cartelas a las cremalleras, el circuito eléctrico queda totalmente conectado y el LED encendido.

- FÁCIL
- RÁPIDO
- PRÁCTICO





# KADÍ ELEKTRIC - PHARMA

## CREMALLERAS



**COLUMNA TROQUELADA  
1 CARA**  
COLONNE PERFORATION SIMPLE  
1 CÔTÉ  
UPRIGHT SINGLE SLOT CHANNEL  
1 SIDE  
TUBO PERFORAZIONE SEMPLICE  
1 LATO

**4786/26B 2678MM**

Fe 60x30x2mm €/u

ZINCADO PL. ZINK  
BLANCO ZINK PL.  
WHITE ZINCATO  
BLANCO

**34 0B**

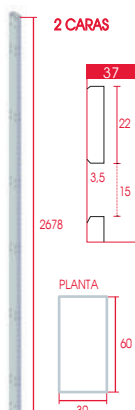

**COLUMNA TROQUELADA  
2 CARAS**  
COLONNE PERFORATION SIMPLE  
2 CÔTÉS  
UPRIGHT SINGLE SLOT CHANNEL  
2 SIDES  
PIANTANA PERFORAZIONE  
SINGOLA 2 LATI

**4787/26B 2678MM  
4787/16B 1337MM**

Fe 60x30x2mm €/u

## GRAPAS



**ANCLAJES PANELES MADERA**  
CROCHET PANNEAUX EN BOIS  
HOOK WOOD PANELS  
GANCIO PER PANNELLI IN LEGNO

**4823/034**

Fe 4814 - 4815 €/u



**ANCLAJES METACRILATO Y  
VIDRIO**  
SUPPORT MÉTHACRYLATE ET  
VERRE  
METHACRYLATE AND GLASS  
SUPPORT  
SUPPORTOPPER PLEXIGLAS E  
VETRO

**4824/034**

Fe 6-8mm €/u

# KADÍ ELEKTRIC - PHARMA

## KITS CARRIL ELECTRIFICADO

PL. M  
ALU. M  
ALU. M  
ALL. NAT

**01**

### KIT 1 CARA



**KIT PERFIL DE ALUMINIO  
ELECTRIFICADO A UNA CARA  
CON GRAPAS DE PLASTICO**  
KIT PROFILÉ ALUMINIUM  
ÉLECTRIFIÉ D'UN CÔTÉ AVEC DES  
AGRAFES EN PLASTIQUE  
KIT ALUMINIUM PROFILE  
ELECTRIFIED ON ONE SIDE WITH  
PLASTIC STAPLES  
KIT PROFILO IN ALLUMINIO  
ELETTRIFICATO SU UN LATO CON  
GRAFFE IN PLASTICA

**4862/241 240 CM**  
**4862/181 180 CM**  
**4862/121 120 CM**

Fe 55x26mm €/m

### Nº COMPONENTES/MEDIDA

MEDIDA	240 cm	180 cm	120 cm
<b>Grapas</b>	X8 uds	X6 uds	X4 uds
<b>Carril electrificado</b>	1 carril de 240	1 carril de 180	1 carril de 120
<b>Tope inferior</b>	X1 ud	X1 ud	X1 ud
<b>Conector Gesis</b>	X1 ud	X1 ud	X1 ud

### KIT 2 CARAS



**KIT PERFIL DE ALUMINIO  
ELECTRIFICADO CON GRAPAS  
DE PLASTICO**  
KIT PROFILÉ ALUMINIUM  
ÉLECTRIFIÉ DOUBLE FACE AVEC  
CLIPS EN PLASTIQUE  
KIT DOUBLE-SIDED ELECTRIFIED  
ALUMINIUM PROFILE WITH  
PLASTIC CLIPS  
KIT PROFILO IN ALLUMINIO  
ELETTRIFICATO BIFACCIALE CON  
CLIPS IN PLASTICA

**4863/241 240 CM**  
**4863/181 180 CM**  
**4863/121 120 CM**

Fe 55x26mm €/m

### Nº COMPONENTES/MEDIDA

MEDIDA	240 cm	180 cm	120 cm
<b>Grapas</b>	X8 uds	X6 uds	X4 uds
<b>Carril electrificado</b>	2 carriles de 240	2 carriles de 180	2 carriles de 120
<b>Tope inferior</b>	X2 uds	X2 uds	X2 uds
<b>Conector Gesis</b>	X2 uds	X2 uds	X2 uds

# KADÍ ELEKTRIC - PHARMA

## MINI-CONECTORES



**CABLE MINI PLUG - ABIERTO 24V**  
CABLE MINI PLUG - OVERTE 24V  
CABLE MINI PLUG - OPEN ENDED 24V  
CAVO MINI PLUG - APERTO 24V  
**4888/009**

Pla	400 mm	€/u
	⚡ 24V 2,5A	



**CABLE MINI PLUG - W PLUG 24V**  
CABLE MINI PLUG - W PLUG 24V  
CABLE MINI PLUG - W PLUG 24V  
CAVO MINI PLUG - W PLUG 24V  
**\*4889/009**

Pla	400 mm	€/u
	⚡ 24V 2,5A	

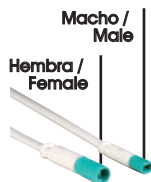

**CABLE CON MINI-CONECTORES 24V**  
CABLE + MINI PLUG - 24V  
CABLE + MINI PLUG - 24V  
CAVO + MINI PLUG - 24V  
**\*4767/009 1M**  
**\*4768/009 2M**

Pla	1/2M	€/u
	⚡ 24V 2,5A	



**ENCHUFE + CABLE + MINI CONECTOR 230V**  
FICHE + CABLE + MINI-PLUG 230V  
EURO-PLUG + CABLE + MINI-PLUG 230V  
SPINA CORRENTE + CAVO + MINI-PLUG 230V  
**\*4773/009**

Pla	3M	€/u
	⚡ 24V 2,5A	

ANTIGUO



NUEVO



El nuevo conector substituirá al antiguo en todas las conexiones una vez agotadas las existencias del antiguo.

## DRIVER



**DRIVER + 6 SALIDAS CON MINI-CONECTORES 24V**  
DRIVER + DISTRIBUTEUR 6 SORTIES AVEC MINI-PLUG 24V  
DRIVER + DISTRIBUTOR 6 WAYS-BLOCK WITH MINI-PLUG 24V  
DRIVER + DISTRIBUTORE 6 USCITE CON MINI-PLUG 24V  
**\*4770/009**

Pla	3 m	⚡ 100 W	€/u
		230V > 24V	

Hembra / Female



**DRIVER + 6 SALIDAS CON MINI-CONECTORES 24V**  
DRIVER + DISTRIBUTEUR 6 SORTIES AVEC MINI-PLUG 24V  
DRIVER + DISTRIBUTOR 6 WAYS-BLOCK WITH MINI-PLUG 24V  
DRIVER + DISTRIBUTORE 6 USCITE CON MINI-PLUG 24V  
**\*4769/009**

Pla	1/2 M	⚡ 24 V	€/u
		2,5 A	

# KADÍ ELEKTRIC - PHARMA

## ACCESORIOS COMUNES



**ENCHUFE + CABLE + DISTRIBUIDOR 6 SALIDAS CON MINI-CONECTORES 230V**  
FICHE + CÂBLE + DISTRIBUTEUR 6 SORTIES AVEC MINI-PLUG 230V  
EURO-PLUG + CABLE + DISTRIBUTOR 6 WAYS-BLOCK WITH MINI-PLUG 230V  
SPINA CORRENTE + CAVO + DISTRIBUTORE 6 USCITE CON MINI-PLUG 230V  
**\*4771/009**

Pla	3M	€/u
	⚡ 230V 2,5A	



**CABLE CON MINI-CONECTORES 230V**  
CABLE + MINI PLUG - 230V  
CABLE + MINI PLUG - 230V  
CAVO + MINI PLUG - 230V  
**\*4772/009**

Pla	3M	€/u
	⚡ 230V 2,5A	

## CONECTORES



### COMPATIBLE KADÍ PRIMO

**CONECTOR PLUG & PLAY, BLANCO / NEGRO**  
CONNECTEUR PLUG & PLAY, BLANC / NOIR  
CONNECTOR PLUG & PLAY, WHITE / BLACK  
CONNETTORE PLUG & PLAY, BIANCO / NERO  
**84864/00B**  
**84864/00N**

Pla	1 m	CE IP20	€/u
		⚡ 24V max.3A	

+ incluye grapa

o

o

6 SALIDAS

**DRIVER 100W, 24V / CONECTOR HEMBRA**  
CONDUCTEUR 100W, 24V / CONNECTEUR FEMELLE  
DRIVER 100W, 24V / FEMALE CONNECTOR  
DRIVER 100W, 24V / CONNETTORE FEMMINA  
**6010/009**

Pla	⚡ 24V 100W	€/u
	15cm	

PLÁSTICO PLASTIQUE PLASTIC PLASTICA  
**09**

o

**CABLE CON MINI-CONECTORES 230V**  
CABLE + MINI PLUG - 230V  
CABLE + MINI PLUG - 230V  
CAVO + MINI PLUG - 230V  
**6015/00B**

Pla	3 m	⚡ 230 V	€/u
		2,5 A	

o

!

## NUEVO

# KADÍ ELEKTRIC - PHARMA

## PIES Y ANCLAJES



**PIE AUTOPORTANTE A PARED**  
 PIED AUTOPORTANT MUR  
 SELF-SUPPORTING FOOD  
 BASE AUTOPORTANTE A PARETE  
**4817/00B**

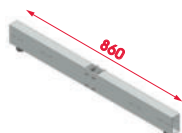

**PIE AUTOPORTANTE GÓNDOLA**  
 PIED GONDOLA  
 GONDOLA FOOD  
 BASE GONDOLA  
**4818/00B**



**ANCLAJE TECHO-SUELO**  
 VÉRIN SUPÉRIEUR  
 UPPER LEVEL  
 LIVELLATORE SUPERIORE  
**4819/00B**



**BASE COLUMNA**  
 VÉRIN INFÉRIEUR  
 LOWER LEVEL  
 LIVELLATORE INFERIORE  
**4820/00B**



**KIT DE Z CON RUEDA DE ALTA RESISTENCIA**  
 KIT Z AVEC ROUE ROBUSTE  
 Z KIT WITH HEAVY DUTY WHEEL  
 Z KIT CON RUOTA PER SERVIZIO PESANTE  
**4818/ROB**



**FIJACIÓN TIRANTES A PARED**  
 PATTES DE FIXATION  
 ROD-SPACER WALL SUPPORT  
 FISSAGIO TIRANTI A PARED  
**4822/00B**

BLANCO  
 BLANC  
 WHITE  
 BIANCO  
**0B**

# KADÍ ELEKTRIC - PHARMA

## TIRANTES

BLANCO  
 BLANC  
 WHITE  
 BIANCO  
**0B**

Fe 80x40x2mm €/u

○

Fe 80x40x2mm €/u

○

Fe 60x30x3mm €/u

○

Fe 60x30x3mm €/u

○

Fe 80x40x2mm €/u

○

Fe 80x40x2mm €/u

○

**TIRANTES DISTANCIADORES**  
 TIRANT-ESPACEMENT  
 ROD-SPACER  
 TIRANTE-DISTANZIATORE

**4821/50B** EJE 512 MM ○  
**4821/60B** EJE 670 MM ○  
**4821/70B** EJE 730 MM ○  
**4821/80B** EJE 820 MM ○  
**4821/10B** EJE 1000 MM ○

**P: PARED (DIST. ENTRE COLUMNAS)**  
**S: SUELO (DIST. ENTRE PIES)**

**NUEVO DISEÑO**  
 MISMO TIRANTE PARA MONTANTES Y PIES

!

NUEVO



**TIRANTE (ILUMINACIÓN)**  
 TIRANT-ESPACEMENT (ÉCLAIRAGE)  
 ROD-SPACER (LIGHTING)  
 TIRANTE (ILLUMINAZIONE)  
**\*4826/70B** EJE 730 MM ○  
**\*4826/80B** EJE 820 MM ○

Fe €/u



**TIRANTE ENTRE PIES**  
 TIRANT-ESPACEMENT ENTRE LE PIED  
 ROD-SPACER BETWEEN FEET  
 TIRANTE FRA BASI MONTANTI  
**\*4827/50B** EJE 512 MM ○  
**\*4827/60B** EJE 650 MM ○

Fe €/u



**TIRANTE TELESCÓPICO**  
 TIRANT TELESCOPIQUE  
 TELESCOPIC ROD-SPACER  
 TIRANTE TELESCOPICO  
**4840/00B** ○

Fe €/u

## JUNTAS Y TAPA



**EMPALMADOR COLUMNA**  
 JOINT COLONNES  
 COLUMNS JOINT  
 GIUNZIONE PIANTANE  
**4825/00B** ○

Fe 90X50 mm €/u

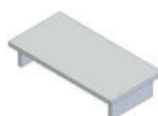

**TAPA COLUMNA**  
 BOUCHON  
 END-CAP UPRIGHT  
 COPRITESTA PIANTANA  
**4828/00B** ○

Fe 60X30 mm €/u



\*  MADERA NO INCLUIDA

# KADÍ ELEKTRIC - PHARMA

## PORTA RÓTULOS 5391/1..

COMPATIBLE KADÍ PRIMO



MATERIAL RÓTULO \*  NO INCLUIDO

CARTELA CON CONECTOR PARA LETREROS CON ILUMINACIÓN 5391/0..

SIN MONTAJE

Placard avec connecteur pour enseignes lumineuses. Placard with connector for illuminated signs. Cartello con connettore per insegne luminose.

1M máx.  7 cm

Fe  72 mm medida útil

BLANCO BLANC WHITE BIANCO	NEGRO NOIR BLACK NERO	COLOR COULEUR COLOR COLORE
OB	ON	OP

€/u

# KADÍ ELEKTRIC - PHARMA

## ESTANTE MADERA 5896/1..

COMPATIBLE KADÍ PRIMO



MADERA \*  NO INCLUIDA

ESTANTE DE MADERA CON ILUMINACIÓN FRONTAL EMPOTRADA Y PERFIL DE ALUMINIO 5896/1..

SIN MONTAJE

Étagère en bois avec éclairage zenithal monté sur l'étagère. Wooden shelf with zenithal lighting mounted on the shelf. Ripiano legno con illuminazione zenitale impiantata nel ripiano.

1M máx.  28 cm

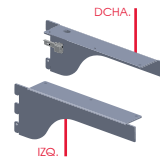

PL. M ALU. M ALU. M ALL. NAT.	BLANCO BLANC WHITE BIANCO	NEGRO NOIR BLACK NERO	COLOR COULEUR COLOR COLORE
01	OB	ON	OP

€/u



Kit 2 cartelas: DERECHA (con conector) + IZQUIERDA

KIT CARTELAS ESTANTE MADERA CON ILUMINACIÓN. KIT SUPPORTS BOIS ILLUMINATION. WOOD LIGHTING BRACKETS KIT. KIT MENSOLE LEGNO ILLUMINAZIONE. 5381/0..

Fe  4890  282 mm medida útil



Medidas mecanizado 16 x 6.8 mm

KIT PERFIL ALUMINIO CON DIFUSOR. KIT PROFIL EN ALUMINIUM AVEC DIFFUSEUR. KIT PROFILO IN ALLUMINIO CON DIFFUSORE. 3971/1..

Al  2M 18x9mm €/m

PLÁSTICO PLASTIC PLASTIC PLASTICA 09



4882/159

PERFIL ALUMINIO. DIFUSOR DE PLÁSTICO MATE. TAPA FINAL. 2 U. PROFIL EN ALUMINIUM. DIFFUSEUR EN PLASTIQUE MAT. EMBOU, 2 U. ALUMINIUM PROFILE. MATT PLASTIC DIFFUSOR. END CAP. 2 U. PROFILO DI ALLUMINIO. DIFUSORE PLASTICO OPACO. TAPPO DI APRIFESTA. 2 U.

Al  3 m 24x7 €/u

 4882

Pla  2 m €/u

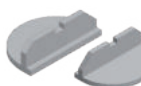

 4892-4894

Pla  4881 €/u



4883/009

LED CON MINI-CONECTOR 24V. BANDE LED AVEC MINI-PLUG 24V. LED STRIP WITH MINI-PLUG 24V. STRIACIA LED CON MINI-PLUG 24V. 4890/009

Pla  1 m  5000 K €/u

 CRI > 90  9,6 W 24V

126 diodos (20λ); cortable cada 5,5 cm. Cable, fil, wire, cavo: 40cm. Ancho 8 mm. flexible y con cinta adhesiva. feible and self-adhesive.

\*  Recomendamos usar vidrios segurizados o laminados. (NO INCLUIDO)

# KADÍ ELEKTRIC - PHARMA

## ESTANTE VIDRIO 5895/1..

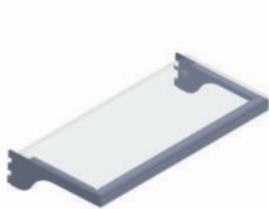

ESTANTE DE VIDRIO CON ILUMINACIÓN FRONTAL 5895/1.. MONTADO

Étagère en verre avec éclairage avant  
Glass shelf with front lighting  
Ripiano vetro con illuminazione frontale

VIDRIO \* NO INCLUIDO 

1M máx. 29 cm

PARA MADERA O VIDRIO



€/u

PL. M	BLANCO	NEGRO	COLOR
ALU. M	BANC	NOR	COULEUR
ALU. M	WHITE	BLACK	COLOR
ALL. NAT	BANCO	NERO	COLORE
01	0B	0N	0P

# KADÍ ELEKTRIC - PHARMA

## ESTANTE VIDRIO 5894/1..



ESTANTE DE VIDRIO CON ILUMINACIÓN CENTRAL FRONTAL 5894/1.. MONTADO

Étagère en verre avec éclairage zenithal frontal  
Glass shelf with frontal zenithal lighting  
Ripiano di vetro con illuminazione zenitale frontale

VIDRIO \* NO INCLUIDO 

1M máx. 27 cm

PARA MADERA O VIDRIO



€/u

PLÁSTICO	BLANCO	NEGRO	COLOR
PLASTIC	BANC	NOR	COULEUR
PLASTICA	WHITE	BLACK	COLOR
	BANCO	NERO	COLORE
09	0B	0N	0P

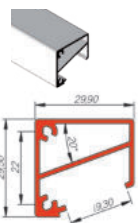

PERFIL ALUMINIO PROFIL EN ALUMINIUM ALUMINIUM PROFILE PROFILO DI ALUMINIO 4744/1..

Al	5 m	30x30	€/m
Ⓞ 84602			

o o o o

Pla	2 m	Ⓞ 4744	€/m
-----	-----	--------	-----

PLÁSTICO	BLANCO	NEGRO	COLOR
PLASTIC	BANC	NOR	COULEUR
PLASTICA	WHITE	BLACK	COLOR
	BANCO	NERO	COLORE
09	0B	0N	0P

o



DIFUSOR PLÁSTICO MATE DIFFUSEUR EN PLASTIQUE MAT MATT PLASTIC DIFUSOR DIFUSORE PLÁSTICO OPACO 84602/109

PLÁSTICO	BLANCO	NEGRO	COLOR
PLASTIC	BANC	NOR	COULEUR
PLASTICA	WHITE	BLACK	COLOR
	BANCO	NERO	COLORE
09	0B	0N	0P

o

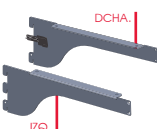

KIT CARTELAS ESTANTE VIDRIO CON ILUMINACIÓN KIT SUPPORTS VERRE ILLUMINATION GLASS LIGHTING BRACKETS KIT KIT MENSOLE VETRO ILLUMINAZIONE 3862/0..

Fe	Ⓞ 4744-2556-4890	€/u
292 mm medida útil		

o o o

Cada cartela tiene 2 taladros para usar 1 perfil 4744  
Kit 2 cartelas: DERECHA (con conector) + IZQUIERDA

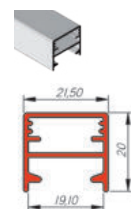

PERFIL ALUMINIO PROFIL EN ALUMINIUM ALUMINIUM PROFILE PROFILO DI ALUMINIO 4748/1..

Al	6 m	21,5x20	€/m
Ⓞ 4893			

o o o

Pla	Ⓞ 4892 - 4894	€/m
-----	---------------	-----

PLÁSTICO	BLANCO	NEGRO	COLOR
PLASTIC	BANC	NOR	COULEUR
PLASTICA	WHITE	BLACK	COLOR
	BANCO	NERO	COLORE
09	0B	0N	0P

o



DIFUSOR PLÁSTICO MATE DIFFUSEUR EN PLASTIQUE MAT MATT PLASTIC DIFUSOR DIFUSORE PLÁSTICO OPACO 4893/109

PLÁSTICO	BLANCO	NEGRO	COLOR
PLASTIC	BANC	NOR	COULEUR
PLASTICA	WHITE	BLACK	COLOR
	BANCO	NERO	COLORE
09	0B	0N	0P

o

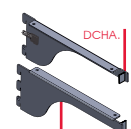

KIT CARTELAS ESTANTE VIDRIO CON ILUMINACIÓN KIT SUPPORTS VERRE ILLUMINATION GLASS LIGHTING BRACKETS KIT KIT MENSOLE VETRO ILLUMINAZIONE 5385/0..

Fe	Ⓞ 4744-2556-4890	€/u
270 mm medida útil		

o o o

Kit 2 cartelas: DERECHA (con conector) + IZQUIERDA



126 diodos (20λ); cortable cada 5,5 cm  
Cable, fil, wire, cavo: 26cm  
Ancho 8mm

flexible y con cinta adhesiva flexible and self-adhesive

LED CON MINI-CONECTOR 24V BANDE LED AVEC MINI-PLUG 24V LED STRIP WITH MINI-PLUG 24V STRIACIA LED CON MINI-PLUG 24V 4890/109

Pla	1 m	⚡ 5000 K	€/u
Ⓞ CRI>90 Ⓢ 9,6 W 24V			

o



126 diodos (20λ); cortable cada 5,5 cm  
Cable, fil, wire, cavo: 26cm  
Ancho 8mm

flexible y con cinta adhesiva flexible and self-adhesive

LED CON MINI-CONECTOR 24V BANDE LED AVEC MINI-PLUG 24V LED STRIP WITH MINI-PLUG 24V STRIACIA LED CON MINI-PLUG 24V 4890/109

Pla	1 m	⚡ 5000 K	€/u
Ⓞ CRI>90 Ⓢ 9,6 W 24V			

o



VENTOSA TRANSPARENTE VENTOUSE SUCITON VENTOSA 2556/009

Pla	∅14 mm	Ⓞ 4880	€/u
-----	--------	--------	-----

o



VENTOSA TRANSPARENTE VENTOUSE SUCITON VENTOSA 2556/009

Pla	∅14 mm	Ⓞ 4880	€/u
-----	--------	--------	-----

o

# KADÍ ELEKTRIC - PHARMA

## ESTANTE VIDRIO 6890/1..

\*  Recomendamos usar vidrios segurizados o laminados. (NO INCLUIDO)

PL. M	BLANCO	NEGRO	COLOR
ALU. M	BLANC	NOIR	COULEUR
ALU. M	WHITE	BLACK	COLOR
ALL. NAT	BIANCO	NERO	COLORE
01	0B	0N	0P



ESTANTE DE VIDRIO RETROILUMINADO 6890/1..

**MONTADO**

Étagère en verre extra claire rétro-éclairé  
Backlit optical glass shelf  
Ripiano vetro extralight retroilluminato

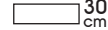
1M máx.  30 cm

**VIDRIO \* NO INCLUIDO** 

€/u

# KADÍ ELEKTRIC - PHARMA

## ESTANTE VIDRIO 6891/1..

PL. M	BLANCO	NEGRO	COLOR
ALU. M	BLANC	NOIR	COULEUR
ALU. M	WHITE	BLACK	COLOR
ALL. NAT	BIANCO	NERO	COLORE
01	0B	0N	0P



ESTANTE DE VIDRIO CON ILUMINACIÓN FRONTAL 6891/1..

**MONTADO**

Étagère en verre avec éclairage zénithal frontal  
Glass shelf with frontal zenithal lighting  
Ripiano di vetro con illuminazione zenitale frontale

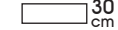
1M máx.  30 cm



**VIDRIO \* NO INCLUIDO** 

€/u



Junta goma incluida  
Joint en caoutchouc inclus  
rubber gasket included  
giunta di gomma inclusa

PERFIL ALUMINIO PROFIL LAME D'ALUMINIUM ALUMINIUM SLATWALL PROFILE PROFILO DOGATO ALLUMINIO 362/1...

Al	 5 m	 6-8mm	€/m
	Ⓞ 361/109		

o o o o

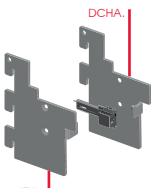

Con perfil 362  
Kit 2 cartelas: DERECHA (con conector) + IZQUIERDA

KIT CARTELAS ESTANTE VIDRIO CON ILUMINACIÓN KIT SUPPORTS VERRE ILLUMINATION GLASS LIGHTING BRACKETS KIT KIT MENSOLE VETRO ILLUMINAZIONE 6860/0..

Fe	Ⓞ 362 - 4890	€/u
	 68,5mm medida útil	



o o o



126 diodos (20λ); cortable cada 5.5 cm  
Cable, fil, wire, cavo: 26cm  
Ancho 8mm

flexible y con cinta adhesiva  
flexible and self-adhesive

LED CON MINI-CONECTOR 24V BANDE LED AVEC MINI-PLUG 24V LED STRIP WITH MINI-PLUG 24V STRIACIA LED CON MINI-PLUG 24V 4890/109

Pla	 1 m	 5000 K	€/u
	Ⓞ CRI>90 Ⓞ 9,6 W 24V		

o

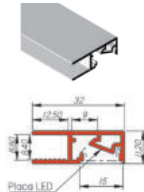

PERFIL ALUMINIO PROFIL EN ALUMINIUM ALUMINIUM PROFILE PROFILO DI ALLUMINIO 4892/1..

Al	 5 m	32x11,2	€/m
	Ⓞ 4893 -4894		

o o o o



DIFUSOR DE PLÁSTICO MATE DIFFUSEUR EN PLASTIQUE MAT MATT PLASTIC DIFUSOR DIFUSORE PLASTICO OPACO 4893/109

Pla	Ⓞ 4892 -4894	€/m
	 2 m	

o



KIT TAPAS FINALES LATERALES COUVERTURE LATÉRALE FINALE LATERAL END CAP COPERTURA LATERALE FINALE 4894/0..



Pla	32x11,2 mm	€/u
	Ⓞ 4892	

o o



flexible y con cinta adhesiva  
flexible and self-adhesive

30 CM CABLE PLANO ADHESIVO 30 CM CÂBLE ADHÉSIF PLAT 30 CM FLAT ADHESIVE CABLE 30 CM CAVO ADESIVO PIATTO 4895/009

Pla	 300 mm	€/u
	 24V-2,5A	

o

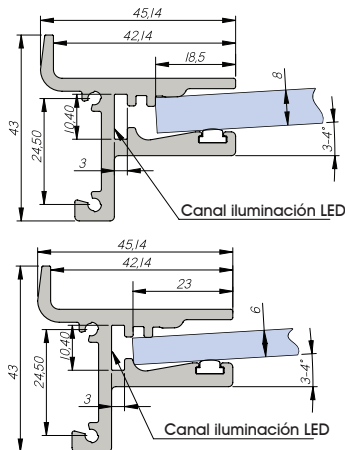

**ES** • MÁXIMA MEDIDA ESTANTE RECOMENDADA: 100 X 30 CM.

**FR** • Maximum recommended shelf size: 100 x 30 cm.

**IT** • Dimensione massima raccomandata dello scaffale: 100 x 30 cm.

**EN** • Taille maximale de l'étagère recommandée: 100 x 30 cm.

# KADÍ ELEKTRIC - PHARMA

## PENDERIE 5897/1..

KIT compuesto por:  
- Cartelas Ref.5382  
-Tubo rectangular Ref.4900/12B  
-LED de 1m



VIDRIO / MADERA NO INCLUIDO

ESTANTE + BARRA DE CUELGUE LATERAL CON ILUMINACIÓN Y PROTECCIÓN PLÁSTICA SUPERIOR 5897/1..

### MONTADO

Tablette + barre de suspension laterale avec éclairage  
Shelf + side hanging bar with lighting  
Mensola + barra appendiabiti laterale con illuminazione

1M máx. 29 cm

PARA MADERA O VIDRIO

PLÁSTICO PLASTIQUE PLASTICA	BLANCO BLANC WHITE BIANCO	NEGRO NOIR BLACK NERO	COLOR COULEUR COLOR COLORE
09	0B	0N	0P

€/u

# KADÍ ELEKTRIC - PHARMA

## BARRA CUELGUE LAT.5898/1..

KIT compuesto por:  
- Cartelas Ref.5383  
-Tubo rectangular Ref.4900/12B  
-LED de 1m



BARRA DE CUELGUE LATERAL CON ILUMINACIÓN Y PROTECCIÓN PLÁSTICA SUPERIOR 5898/1..

### MONTADO

Barre de suspension laterale avec éclairage  
Side hanger bar with lighting  
Barra appendiabiti laterale con illuminazione

1M máx. 29 cm

PL. M ALL. M ALL. M ALL. NAT	BLANCO BLANC WHITE BIANCO	NEGRO NOIR BLACK NERO	COLOR COULEUR COLOR COLORE
01	0B	0N	0P

€/u

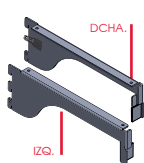

Kit 2 cartelas: DERECHA (con conector) + IZQUIERDA

KIT CARTELAS BARRA ACCESORIOS  
KIT SUPPORT BARRE ACCESSOIRES  
KIT BRACKET FOR ACCESSORIES ROD  
KIT MENSOLA TUBO PORTA-ACCESSORI 5382/00.

Fe	⊘ 4900	€/u
290 mm medida útil		

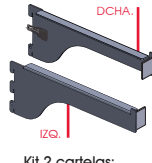

Kit 2 cartelas: DERECHA (con conector) + IZQUIERDA

KIT CARTELAS BARRA ACCESORIOS  
KIT SUPPORT BARRE ACCESSOIRES  
KIT BRACKET FOR ACCESSORIES ROD  
KIT MENSOLA TUBO PORTA-ACCESSORI 5383/00.

Fe	⊘ 4900	€/u
290 mm medida útil		

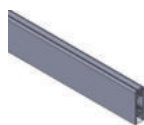

LED no incluido. LED recomendado de 5mm de ancho. Incluye perfil de plástico superior y difusor interior.

TUBO RECTANGULAR PARA ILUMINACIÓN 30X10MM CON PLETINA DE REFUERZO  
KIT TUBE RECTANGULAIRE POUR ECLAIRAGE 30X10MM AVEC PLAQUE DE RENFORT  
KIT RECTANGULAR TUBE FOR LIGHTING 30X10MM WITH REINFORCING PLATE  
KIT TUBO RETTANGOLARE PER ILLUMINAZIONE 30X10MM CON PIASTRA DI RINFORZO 4900/12.  
CON ALMA DE ACERO INOX

Al	⊔ 1 m	30x10	€/u
⊘ 4901			

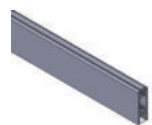

LED no incluido. LED recomendado de 5mm de ancho. Incluye perfil de plástico superior y difusor interior.

TUBO RECTANGULAR PARA ILUMINACIÓN 30X10MM CON PLETINA DE REFUERZO  
KIT TUBE RECTANGULAIRE POUR ECLAIRAGE 30X10MM AVEC PLAQUE DE RENFORT  
KIT RECTANGULAR TUBE FOR LIGHTING 30X10MM WITH REINFORCING PLATE  
KIT TUBO RETTANGOLARE PER ILLUMINAZIONE 30X10MM CON PIASTRA DI RINFORZO 4900/12.  
CON ALMA DE ACERO INOX

Al	⊔ 1 m	30x10	€/u
⊘ 4901			



182 diodos (20λ); cortable cada 3.8 cm  
Cable, fil. wire, cavo: 40cm  
Ancho 5mm

flexible y con cinta adhesiva flexible and self-adhesive

LED CON MINI-CONECTOR 24V  
BANDE LED AVEC MINI-PLUG 24V  
LED STRIP WITH MINI-PLUG 24V  
STRACIA LED CON MINI-PLUG 24V 4910/109

Pla	⊔ 1 m	5000 K	€/u
⊘ CRI > 90 15,3W 24V			

PLÁSTICO PLASTIQUE PLASTICA 09



182 diodos (20λ); cortable cada 3.8 cm  
Cable, fil. wire, cavo: 40cm  
Ancho 5mm

flexible y con cinta adhesiva flexible and self-adhesive

LED CON MINI-CONECTOR 24V  
BANDE LED AVEC MINI-PLUG 24V  
LED STRIP WITH MINI-PLUG 24V  
STRACIA LED CON MINI-PLUG 24V 4910/109

Pla	⊔ 1 m	5000 K	€/u
⊘ CRI > 90 15,3W 24V			

PLÁSTICO PLASTIQUE PLASTICA 09



VENTOSA TRANSPARENTE VENTOUSE SUCITON VENTOSA 2556/009

Pla	⊘ 14 mm	⊘ 4880	€/u
-----	---------	--------	-----

# KADÍ ELEKTRIC - PHARMA

## BARRA ACCES. FR. 5901/1..

KIT compuesto por:  
- Cartelas Ref. 5380  
-Tubo rectangular  
Ref.4900/12B  
-LED de 1m



**BARRA DE CUELQUE PARA  
ACCESORIOS FRONTALES  
CON ILUMINACIÓN Y  
PROTECCIÓN PLÁSTICA  
SUPERIOR**  
**5901/1..**

**MONTADO**

Barre de suspension pour  
accessoires avant avec  
éclairage  
Hanger bar for front  
accessories with lighting  
Barra appendibili per  
accessori frontali con  
illuminazione

1M máx.  
7  
cm

PL. M	BLANCO	NEGRO	COLOR
ALU. M	BLANC	NOR	COULEUR
ALU. M	WHITE	BLACK	COLOR
ALL. NAT	BANCO	NERO	COLORE
01	0B	0N	0P
			€/u
	○	○	○
			€/u
	○	○	○
			€/m
	○	○	○
			€/u
	○	○	○

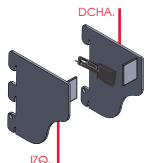

Kit de 2  
cartelas:  
DERECHA (con  
conector) +  
IZQUIERDA

**KIT CARTELAS BARRA  
ACCESORIOS**  
KIT SUPPORT BARRE  
ACCESSOIRES  
KIT BRACKET FOR  
ACCESSORIES ROD  
KIT MENSOLA TUBO  
PORTA-ACCESSORI

**5380/0..**

Fe 4900 71 mm medida útil €/u

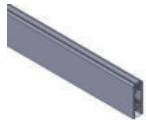

LED no incluido.  
LED  
recomendado de  
5mm de ancho.  
Incluye perfil de  
plastico superior y  
difusor interior.

**KIT TUBO RECTANGULAR  
PARA ILUMINACIÓN  
30X10MM**  
KIT TUBE RECTANGULAIRE  
POUR ECLAIRAGE  
30X10MM  
KIT RECTANGULAR TUBE  
FOR LIGHTING 30X10MM  
KIT TUBO RETTANGOLARE  
PER ILLUMINAZIONE  
30X10MM

**4900/10.**

Al 6 m 30x10 €/m  
4901



182 diodos (20λ);  
cortable cada  
3,8 cm  
Cable, fil. wire,  
cavo: 45 mm  
Ancho 5mm  
flexible y con  
cinta adhesiva  
flexible and  
self-adhesive

**LED CON  
MINI-CONECTOR 24V**  
BANDE LED AVEC  
MINI-PLUG 24V  
LED STRIP WITH  
MINI-PLUG 24V  
STRACIA LED CON  
MINI-PLUG 24V

**4901/109**

Pla 1 m 5000 K €/u  
CRI > 90 15,3W 24V

PLÁSTICO  
PLASTIQUE  
PLASTIC  
PLASTICA  
**09**

## EJEMPLO DE APLICACIÓN

Barras de  
accesorios con  
cuelgue frontal.

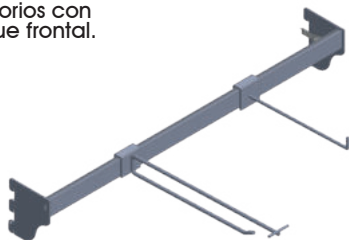

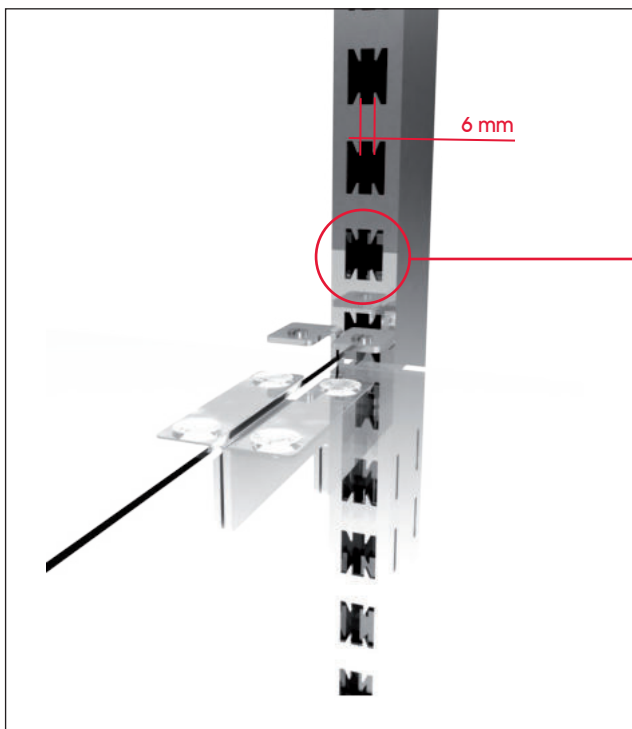
**KADÍ - PHARMA DUO**AUTOPORTANTE - AUTOPORTANT  
SEL-SUPPORTING - AUTOPORTANTE

6 mm

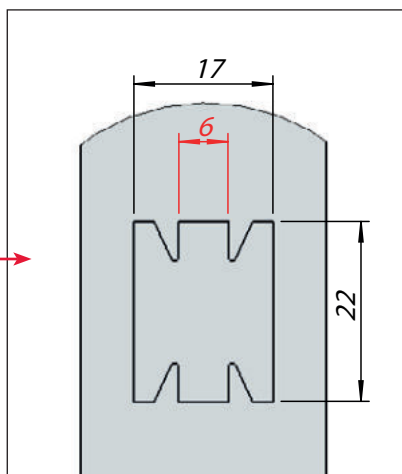

-Con un troquel más ancho.  
-Posibilidad de dos cartelas  
en el mismo alojamiento.

-Avec une mort plus large.

-Possibilité de deux cartes  
dans le même perforation

-With a wider die.

-Possibility to put two brack-  
ets in the same slot.

-Con un dado più ampio.  
-Possibilità di due mensole  
nella stessa asola.

Con la columna PHARMA DUO se pueden usar dos cartelas en un mismo troquel y poder configurar distintas alturas de estantes entre columnas.

Avec la colonne PHARMA DUO, vous pouvez utiliser deux cartes dans la même matrice et vous pouvez configurer différentes hauteurs entre étagères entre colonnes.

With the PHARMA DUO column you can use two brackets in the same die and configure different heights of shelves between columns.

Con la colonna PHARMA DUO è possibile utilizzare due mensole nella stessa asola e regolare i ripiani individualmente.

# KADÍ - PHARMA DUO

AUTOPORTANTE - AUTOPORTANT  
SEL-SUPPORTING - AUTOPORTANTE

## CARACTERÍSTICAS DEL SISTEMA

- Compatible con la mayoría de accesorios del sistema Kadí
- Módulos de 512, 730 y 820 mm entre ejes de columna
- Posibilidad de regular altura de estantes independientemente.
- Sistema modular que permite la combinación de 3 soluciones:

## CARACTÉRISTIQUES DU SYSTÈME

- Compatible avec la plupart des accessoires Kadí
- Modules de 512, 730 et 820 mm empattement colonne
- Possibilité de hauteur régulière des étagères indépendantes
- Système modulaire qui permet la combinaison de 3 solutions:

## SYSTEM FEATURES

- Compatible with most Kadí system accessories
- Modules 512, 730 and 820 mm column between axes
- Possibility to adapt height of independent shelves
- Modular system that allows the combination of 3 solutions:

## CARATTERISTICHE DEL SISTEMA

- Compatibile con la maggior parte degli accessori del sistema Kadí
- Moduli di 512, 730 e 820 mm fra assi dei montanti
- Possibilità di altezze regolari di mensole indipendenti
- sistema modulare che permette la combinazione di 3 soluzioni:

## Solución TECHO-SUELO

Solution SOL-PLAFOND  
Solution CEILING-FLOOR  
Soluzione SUOLO-SOFFITTO

## Solución PARED

Solution MUR  
Solution WALL  
Soluzione PARETE

## Solución GÓNDOLA ó PARED DIVISORIA

Solution GONDOLA ou PARIÓI SÉPARATRICE  
Solution GONDOLA or PARTITION WALL  
soluzione GONDOLA o parete divisoria

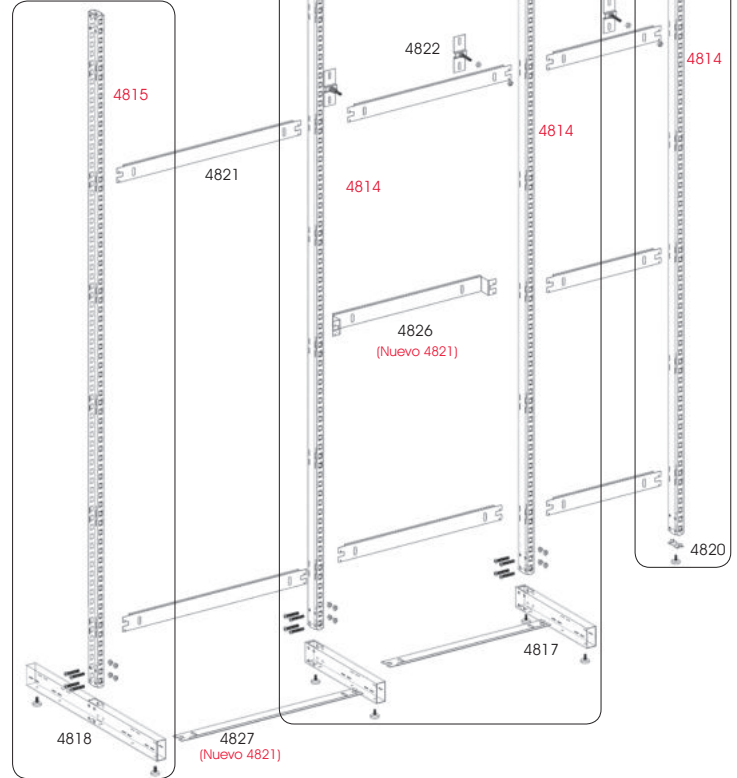
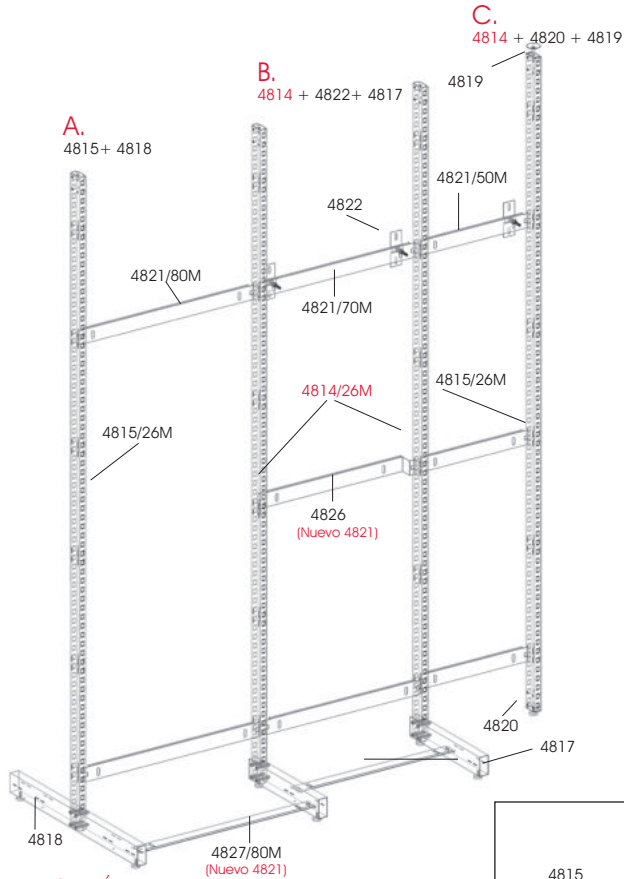

## Solución GÓNDOLA

Solution GONDOLA  
Solution GONDOLA  
soluzione GONDOLA

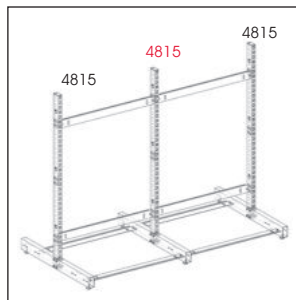

## 4821 TIRANTES EN PLANO DIFERENTES NUEVOS TIRANTES 4821 (APTOS PARA PIES Y MONTANTES)

El uso de tirantes de unión en planos diferentes confiere más estabilidad a la góndola.

La utilisation de tirants dans de planes différents donne plus de stabilité à la gondole

The use of rods spacer in different planes gives more stability to the gondola.

L'impiego di tiranti su piani differenti conferisce maggiore stabilità alla gondola.

## 4827 TIRANTE PARA PIES

El uso de tirantes de unión en planos diferentes confiere más estabilidad a la góndola.

La utilisation de tirants dans la base donne plus de stabilité à la gondole

The use of rods spacer in the base gives more stability to the gondola.

L'impiego di tiranti nella base conferisce maggiore stabilità alla gondola.

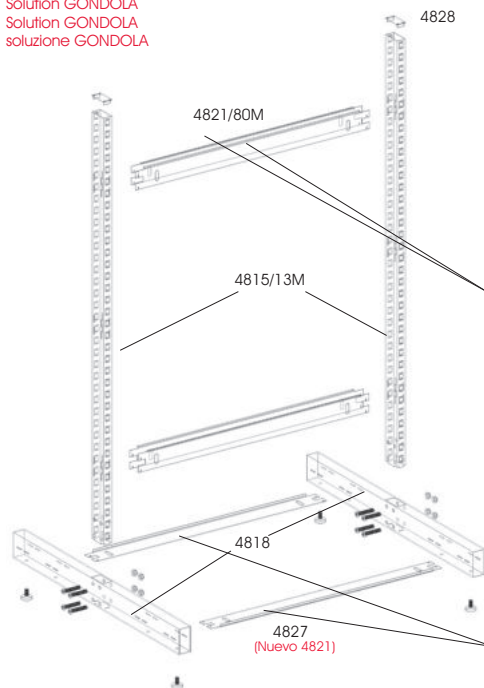

## Solución ELECTRIFICADO

Solution ÉLECTRIFIÉE  
Solution ELECTRIFIED  
Soluzione ELETRIFICATA







# KADÍ - PHARMA DUO

AUTOPORTANTE - AUTOPORTANT  
SEL-SUPPORTING - AUTOPORTANTE

GRIS 7035	BLANCO	NEGRO	COLOR
GRIS 7035	BLANC	NOIR	COULEUR
GRIS 7035	WHITE	BLACK	COLOR
GRIGIO 7035	BIANCO	NERO	COLORE
OM	OB	ON	OP

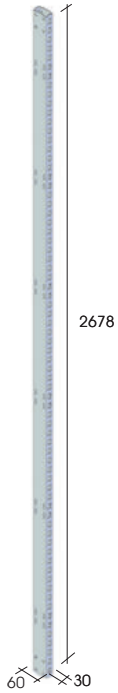

**COLUMNA TROQUELADA 2 CARAS**  
COLONNE PERFORATION SIMPLE 2 CÔTES  
UPRIGHT SINGLE SLOT CHANNEL 2 SIDES  
PIANTANA PERFORAZIONE SINGOLA 2 LATI  
**4815/26B** 2678 mm

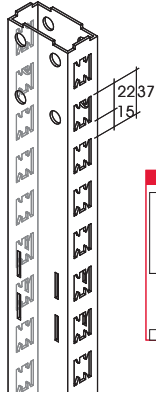

Fe	60x30x2 mm	€/u
----	------------	-----

# KADÍ - PHARMA DUO

AUTOPORTANTE - AUTOPORTANT  
SEL-SUPPORTING - AUTOPORTANTE

GRIS 7035	BLANCO	NEGRO	ZINCADO
GRIS 7035	BLANC	NOIR	PL. ZNK
GRIS 7035	WHITE	BLACK	ZNK PL.
GRIGIO 7035	BIANCO	NERO	ZINCATO
OM	OB	ON	34



**COLUMNA TROQUELADA 1 CARA**  
COLONNE PERFORATION SIMPLE 1CÔTÉ  
UPRIGHT SINGLE SLOT CHANNEL 1 SIDE  
TUBO PERFORAZIONE SEMPLICE 1 LATO  
**4814/26B** 2678 mm

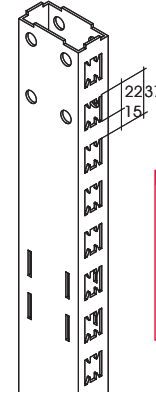

Fe	60x30x2 mm	€/u
----	------------	-----

**COLUMNA TROQUELADA 2 CARAS**  
COLONNE PERFORATION SIMPLE 2 CÔTES  
UPRIGHT SINGLE SLOT CHANNEL 2 SIDES  
PIANTANA PERFORAZIONE SINGOLA 2 LATI  
**4815/13B** 1337 mm

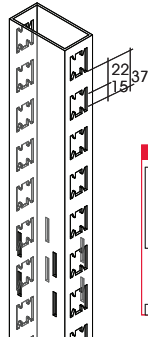
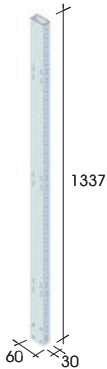

Fe	60x30x2 mm	€/u
----	------------	-----

	GRUESOS PANELES		
	10 mm	16 mm	19 mm
4645-4646	S	N	N
4620-4621	S	N	N
4622-4623	S	N	N
4626	S	N	N
4652-4653	S	S	S
4654-4655	S	N	N
4656-4657	S	N	N
4705	N	N	N
4706	N	N	N
4708	N	N	N
4715-4716	S	S	S
4717	S	S	S
4730	N	N	N
4731	N	N	N
4732	S	N	N
4733	S	S	S
serie TUBULARES	N	N	N
4618	S	S	S
4619	S	S	S
4680	S	S	S
4681	S	S	S
4682	S	S	S
4683	S	S	S
4684	S	S	S
4695	S	S	S
4696	S	S	S
4691-4692	S	S	S
4693-4694	S	S	S
4844-4845	S	S	S
4846-4847	S	S	S
5844	S	S	S
5845	S	S	S
5846	S	S	S

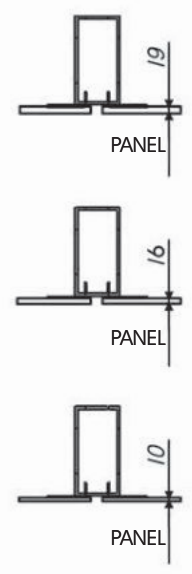

**ANCLAJES PANELES MADERA**  
CROCHET PANNEAUX EN BOIS  
HOOK WOOD PANELS  
GANCHO PER PANNELLI IN LEGNO  
**4823/034**



Fe	∞ 4814-4815	€/u
----	-------------	-----

**ANCLAJES METACRILATO Y VIDRIO**  
SUPPORT METHACRYLATE ET VERRE  
METHACRYLATE AND GLASS SUPPORT  
SUPPORTO PER PLEXIGLAS E VETRO  
**4824/034**



Fe	max.8 mm	€/u
----	----------	-----

Utilizar las cartelas con panel adecuado.  
Utilisez le supports avec un panneau approprié.  
USE the adequated bracket for the thickness panel  
Utilizzare la mensola con pannello idoneo.

# KADÍ - PHARMA DUO

AUTOPORTANTE - AUTOPORTANT  
SEL-SUPPORTING - AUTOPORTANTE

GRIS 7035	BLANCO 7035	NEGRO 7035	COLOR 7035
GRAS 7035	BLANC 7035	NOR 7035	COULEUR 7035
GREY 7035	WHITE 7035	BLACK 7035	COLOR 7035
GRIGIO 7035	BIANCO 7035	NERO 7035	COLORE 7035
OM	OB	ON	OP

Fe	80x40x2 mm	€/u
----	------------	-----

--	--	--	--

Fe	80x40x2 mm	€/u
----	------------	-----

--	--	--	--

Fe	60x30x3 mm M8	€/u
----	---------------	-----

--	--	--	--

Fe	60x30x3 mm M8	€/u
----	---------------	-----

--	--	--	--

Fe	40Kg	M10	€/u
----	------	-----	-----

--	--	--	--

--	--	--	--

--	--	--	--

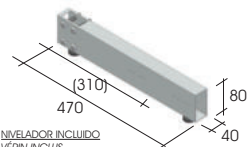

PIE AUTOPORTANTE A PARED  
PIED AUTOPORTANT MUR  
SELF-SUPPORTING FOOT  
BASE AUTOPORTANTE A PARETE  
**4817/00B**

NIVELADOR INCLUIDO  
VERIN INCLUS  
LEVEL INCLUDED  
LIVELLATORE INCLUSO

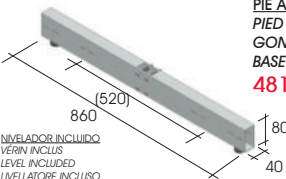

PIE AUTOPORTANTE GÓNDOLA  
PIED GONDOLA  
GONDOLA FOOT  
BASE GONDOLA  
**4818/00B**

NIVELADOR INCLUIDO  
VERIN INCLUS  
LEVEL INCLUDED  
LIVELLATORE INCLUSO



ANCLAJE TECHO-SUELO  
VERIN SUPÉRIEUR  
UPPER LEVEL  
LIVELLATORE SUPERIORE  
**4819/00B**



BASE COLUMNA  
VERIN INFÉRIEUR  
LOWER LEVEL  
LIVELLATORE INFERIORE  
**4820/00B**



KIT DE Z CON RUEDA DE  
ALTA RESISTENCIA  
KIT Z AVEC ROUE ROBUSTE  
Z KIT WITH HEAVY DUTY WHEEL  
Z KIT CON RUOTA PER SERVIZIO PESANTE  
**4818/ROB**

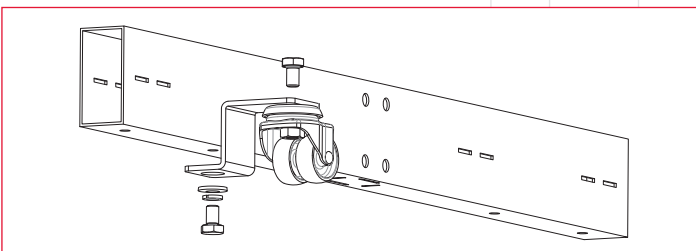

# KADÍ - PHARMA DUO

AUTOPORTANTE - AUTOPORTANT  
SEL-SUPPORTING - AUTOPORTANTE

CR.BRILLO	BLANCO	NEGRO	ZINCADO
CR.POLI	BLANC	NOR	PL. ZINK
BR.CH	WHITE	BLACK	ZINK PL.
CR.LL.C.	BIANCO	NERO	ZINCATO
32	OB	ON	34

Fe		€/u
----	--	-----

--	--	--	--

Fe		€/u
----	--	-----

--	--	--	--

Fe		€/u
----	--	-----

--	--	--	--

Fe		€/u
----	--	-----

--	--	--	--

Fe		€/u
----	--	-----

--	--	--	--

Fe	M10	€/u
----	-----	-----

--	--	--	--

Fe	60x30 mm	€/u
----	----------	-----

--	--	--	--

--	--	--	--

--	--	--	--

Fe	60mm	∞ 4547 (36x18)	€/u
----	------	----------------	-----

--	--	--	--

Fe	60mm	∞ 4547 (36x18)	€/u
----	------	----------------	-----

--	--	--	--

--	--	--	--

Fe	3 m	36x18x1,5	€/m
----	-----	-----------	-----

--	--	--	--

--	--	--	--

Fe	∞ 4547-382		€/u
----	------------	--	-----

--	--	--	--

--	--	--	--

--	--	--	--

Fe	54,5 <-> 100 cm	€/u
----	-----------------	-----

--	--	--	--

Fe	40x50 mm		€/u
----	----------	--	-----

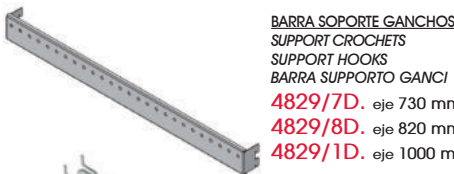

BARRA SOPORTE GANCHOS  
SUPPORT CROCHETS  
SUPPORT HOOKS  
BARRA SUPPORTO GANCI  
**4829/7D.** eje 730 mm  
**4829/8D.** eje 820 mm  
**4829/1D.** eje 1000 mm

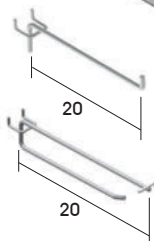

GANCHO  
CROCHET  
HOOK  
BARRETTA  
**445/X..** 20 cm

GANCHO PORTAPRECIO  
CROCHET PORTAPRIX  
HOOK LABEL-HOLDER  
BARRETTA PORTAPREZZO  
**447/X..** 20 cm

PORTAPRECIO  
PORTAPRIX  
LABELHOLDER  
PORTAPREZZO  
**382/009**

CARTELA PARA COLGAR MUEBLES  
SUPPORT POUR MOBILE  
FURNITURE BRACKET  
MESNOLA PER MOBILI  
**4733/032**

EMPALMADO COLUMNA  
JOINT COLONNES  
COLUMNS JOINT  
GIUNZIONE PIANTANE  
**4825/00B**

TAPA COLUMNA  
BOUCHON  
END-CAP UPRIGHT  
COPRITESTA PIANTANA  
**4828/00B**

# KADÍ - PHARMA DUO

## CARTELA FINAL BARRA ACCESORIOS (36X18)

CARTELA BARRA ACCESORIOS  
SUPPORT BARRA ACCESSORIES  
BRACKET FOR ACCESSORIES ROD  
MENSOLA TUBO PORTA ACCESSORI  
**4716/0..** derecha  
droite/right/destra  
**4717/0..** izquierda  
gauche/left/sinistra

CARTELA BARRA ACCESORIOS  
SUPPORT BARRA ACCESSORIES  
BRACKET FOR ACCESSORIES ROD  
MENSOLA TUBO PORTA ACCESSORI  
**4715/0..** intermedia  
inter./inter./inter.

## TUBO OVALADO 36X18

TUBO OVAL 36x18 mm  
TUBE OVALE 36x18 mm  
OVAL TUBE 36x18 mm  
TUBO OVALE 36x18 mm  
**4547/1..**

GANCHO PORTAPRECIO  
CROCHET PORTAPRIX  
HOOK LABEL-HOLDER  
BARRETTA PORTAPREZZO  
**3012/0..** 25 cm

PORTAPRECIO  
PORTAPRIX  
LABELHOLDER  
PORTAPREZZO  
**382/009**



TIRANTES DISTANCIADORES  
TIRANT-ESPACEMENT  
ROD-SPACER  
TIRANTE-DISTANZIATORE  
**4821/50B** eje 512 mm  
**4821/60B** eje 670 mm  
**4821/70B** eje 730 mm  
**4821/80B** eje 820 mm  
**4821/10B** eje 1000 mm

NUEVO DISEÑO  
MISMO TIRANTE  
PARA MONTANTES  
Y PIES

**! NUEVO**



FIJACIÓN TIRANTES A PARED  
PATTES DE FIXATION  
ROD-SPACER WALL SUPPORT  
FISSAGIO TIRANTI A PARED  
**4822/00B**



TIRANTE (ILUMINACIÓN)  
TIRANT-ESPACEMENT (ÉCLAIRAGE)  
ROD-SPACER (LIGHTING)  
TIRANTE (ILLUMINAZIONE)  
**\*4826/70B** eje 730 mm  
**\*4826/80B** eje 820 mm



TIRANTE ENTRE PIES  
TIRANT-ESPACEMENT ENTRE LE PIED  
ROD-SPACER BETWEEN FEET  
TIRANTE FRA BASI MONTANTI  
**\*4827/50B** eje 512 mm  
**\*4827/70B** eje 730 mm

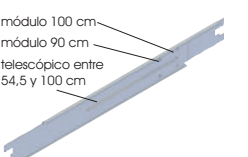

TIRANTES TELESCÓPICO  
TIRANT TELESCOPIQUE  
TELESCOPIC ROD-SPACER  
TIRANTE TELESCOPICO  
**4840/00B**

# KADÍ - PHARMA

AUTOPORTANTE - AUTOPORTANT  
SEL-SUPPORTING - AUTOPORTANTE

CR. BRILLO	INOX	SAT	CR. MATE	BLANCO	NEGRO	COLOR
CH-R, POLI	INOX	SAT	CH-R, M	BLANC	NOIR	COULEUR
CR. CH-R	S.S.S.	INOX	M. CHR	WHITE	BLACK	COLOR
CR. ILLC.	INOX	SAT	CR. CPAC	BLANCO	NERO	COLORE
32	28	31	0B	0N	0P	

CR. BRILLO	CR. MATE	BLANCO	NEGRO	COLOR
CH-R, POLI	CH-R, M	BLANC	NOIR	COULEUR
CR. CH-R	M. CHR	WHITE	BLACK	COLOR
CR. ILLC.	CR. CPAC	BLANCO	NERO	COLORE
32	31	0B	0N	0P



**CARTELA FINAL ANTIVUELCO**  
SUPPORT FINAL ANTIBASCULAMENT  
FINAL BRACKET ANTITIPPING  
MENSOLA FINALE ANTRIBALTAMENTO  
**\*4618/3..** \*o \*o

Fe	8 mm		€/u
----	------	--	-----

SE RECOMIENDA ESTANTE DE VIDRIO TEMPLADO DE 30CM DE PROFUNDIDAD



**CARTELA INTERMEDIA ANTIVUELCO**  
SUPPORT INTERMÉDIAIRE ANTIBASCULAMENT  
INTERMEDIATE BRACKET ANTITIPPING  
MENSOLA INTERMEDIA ANTRIBALTAMENTO  
**\*4619/3..** \*o \*o

Fe	8 mm		€/u
----	------	--	-----

SE RECOMIENDA ESTANTE DE VIDRIO TEMPLADO DE 30CM DE PROFUNDIDAD

## CARTELA "SILUETTE"



**CARTELA SUPPORT BRACKET MENSOLA**

Fe	8 mm		€/u
----	------	--	-----

4680-4681-4682

**4680/0..** 14cm o o o  
**4681/0..** 23cm o o o  
**4682/0..** 28cm o o o  
**4683/0..** 33cm o o o  
**4684/0..** 38cm o o o



4683-4684

## CARTELA "SILUETTE" INCLINADA



**CARTELA INCLINADA 30°**  
SUPPORT INCLINÉE 30°  
SLOPPING BRACKET 30°  
MENSOLA INCLINATA 30°  
**4696/0..** 32cm o o o

Fe	∞ 4700-4701		€/u
----	-------------	--	-----

## CABALLETES ESTANTES PARA CARTELAS



**ALETA FINAL CAVALIER FINAL FINAL SADDLES CAVALIERE FINALE**  
**4700/0..** o o o

Fe	∞ 4702-319-2556		€/u
----	-----------------	--	-----



**ALETA INTERMEDIA CAVALIER DOUBLE BOUBLE SADDLES CAVALIERE DOPPIO**  
**4701/0..** o o o

Fe	∞ 4702-319-2556		€/u
----	-----------------	--	-----



**APOYO APPUI SUPPORT APPOGGIO**  
**4702/009** o

plas	∅9	∞ 4700-4701	€/u
------	----	-------------	-----



**VENTOSA VENTOUSE SUCTION VENTOSA**  
**319/009** o

plas	∅20	∞ 4700-4701	€/u
------	-----	-------------	-----



**VENTOSA VENTOUSE SUCTION VENTOSA**  
**2556/009** o

plas	∅14	∞ 4700-4701	€/u
------	-----	-------------	-----

**ESTANTES DE VIDRIO 8 mm**  
support verre 8 mm recommandée  
recommended 8mm glass bracket  
mensola per vetro 8 mm consigliata



**ESTANTES DE MADERA O VIDRIO**  
supports verre/bois recommandée  
recommended glass/wood brackets  
mensola per vetro/legno consigliate



# KADÍ - PHARMA DUO

**CARTELAS ESPECIALES PARA PHARMA, CREMALLERA DUO Y ELECTRIFICADO. (APTO PARA TODOS LOS SISTEMAS KADÍ)**



**CARTELA SUPPORT BRACKET MENSOLA**  
**5844/...** derecha droite/right/destra o o o  
**5845/...** izquierda gauche/left/sinistra o o o  
**5846/...** doble double/double/doppio o o o

Fe	8-10 mm	14,9 cm	€/u
----	---------	---------	-----

**! NUEVO**

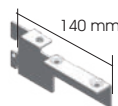

**CARTELA DERECHA SUPPORT DROITE RIGHT BRACKET MENSOLA DESTRA**  
**\*4844/0..** \*o \*o

Fe	8-10 mm	140 mm	€/u
----	---------	--------	-----

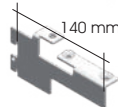

**CARTELA IZQUIERDA SUPPORT GAUCHE LEFT BRACKET MENSOLA SINISTRA**  
**\*4845/0..** \*o \*o

Fe	8-10 mm	140 mm	€/u
----	---------	--------	-----

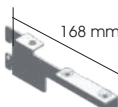

**CARTELA DERECHA SUPPORT DROITE RIGHT BRACKET MENSOLA DESTRA**  
**\*4846/0..** \*o \*o

Fe	8-10 mm	168 mm	€/u
----	---------	--------	-----

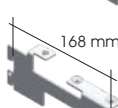

**CARTELA IZQUIERDA SUPPORT GAUCHE LEFT BRACKET MENSOLA SINISTRA**  
**\*4847/0..** \*o \*o

Fe	8-10 mm	168 mm	€/u
----	---------	--------	-----

## "SILUETTE" PLEGADA



**CARTELA SUPPORT BRACKET MENSOLA**  
**4692/0..** derecha droite/right/destra o o o  
**4691/0..** izquierda gauche/left/sinistra o o o

Fe	23 cm		€/u
----	-------	--	-----



**4694/0..** derecha droite/right/destra o o o  
**4693/0..** izquierda gauche/left/sinistra o o o

Fe	28 cm		€/u
----	-------	--	-----

## CARTELAS "GRANDES PESOS"



**CARTELA GRANDES PESOS SUPPORT GRAN POID BRACKET HEAVY WEIGHT MENSOLA GRANDI PESI**  
**4652/0..** derecha droite/right/destra o o o  
**4653/0..** izquierda gauche/left/sinistra o o o

Fe	35 cm		€/u
----	-------	--	-----

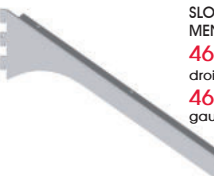

**CARTELA INCLINADA 30° SUPPORT INCLINÉE 30° SLOPPING BRACKET 30° MENSOLA INCLINATA 30°**  
**4632/0..** derecha droite/right/destra o o o  
**4633/0..** izquierda gauche/left/sinistra o o o

Fe	38 cm		€/u
----	-------	--	-----



La profundidad de estante recomendado para las cartelas suspendidas de la gama "CARTELAS ESPECIALES VIDRIO" es de **25-30 cm max.**  
La profundidad del estante interfiere directamente en la capacidad y resistencia de aguante de las mismas cartelas y de todo el sistema.



## KADÍ - PHARMA

AUTOPORTANTE - AUTOPORTANT  
SEL-SUPPORTING - AUTOPORTANTE

GRIS 7035	BLANCO	NEGRO	CR. BRILLO
GRIS 7035	BLANC	NOR	CR. POLI
GREY 7035	WHITE	BLACK	BR. CR
GRIGIO 7035	BIANCO	NERO	CR. LUC.
OM	OB	ON	32

inox  
s.s. €/u



ANCLAJE MULTILAMA A TIRANTE 4821  
FIXATION MULTILAMA-TIRANT 4821  
MULTILAMA-ROD SPACER 4821 JOINT  
AGGANGIO MULTILAMA-TIRANTE 4821  
4838/000

## MULTILAMA

MULTILAMA aluminio  
regata cada 12,5 mm

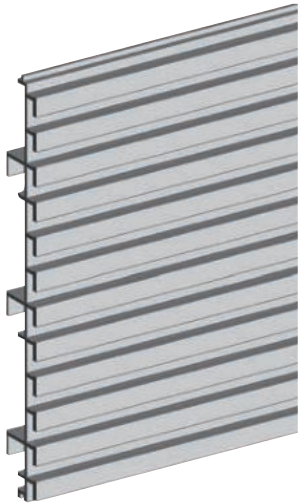

MULTILAMA ALUMINIO  
12 CANALES (12,5 MM)  
PROFIL LAMIE D'ALUMINIUM  
12 rainures chaque 12,5 mm  
ALUMINIUM SLATWALL PROFILE  
12 Slots every 12,5 mm  
PROFILO DOGATO ALLUMINIO  
12 ranure ogni 12,5 mm  
401/1..

BLANCO	NEGRO	COLOR	PL. M
BLANC	NOR	COULEUR	ALU. M
WHITE	BLACK	COLOR	ALU. M
BIANCO	NERO	COLORE	ALL. NAT
OB	ON	OP	O1

Al 5 m ∞ 400 €/m

ZINCADO  
PL. ZINK  
ZINK PL.  
ZINCATO  
34

## KADÍ - PHARMA+MULTILAMA

AUTOPORTANTE - AUTOPORTANT  
SEL-SUPPORTING - AUTOPORTANTE

Solución con MULTILAMA  
Solution avec MULTILAMA  
Solution with MULTILAMA  
Soluzione con MULTILAMA

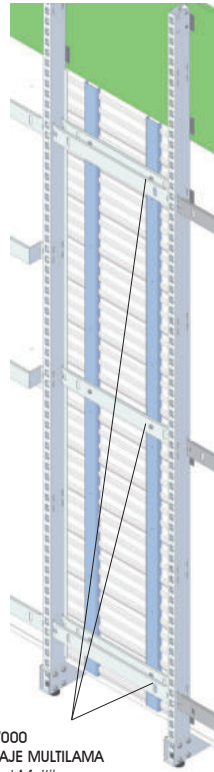

4838/000  
ANCLAJE MULTILAMA  
support Multilama  
support Multilama  
supporto multilama

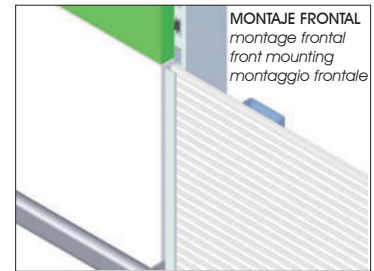

MONTAJE FRONTAL  
montage frontal  
front mounting  
montaggio frontale

1650/1..  
REMATE ÁNGULO 15X15  
profil lateral de finition  
lateral finishing profile  
profilo laterale di finitura

1651/1..  
REMATE ÁNGULO 20X20  
profil lateral de finition  
lateral finishing profile  
profilo laterale di finitura

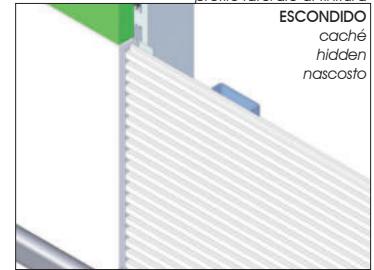

ESCONDIDO  
caché  
hidden  
nascosto

## Guía pared MULTILAMA



CREMALLERA PARED  
PARA PERFILES 401, 403  
CRÉMAILLÈRE MUR  
Avec profils 403 et 401  
WALL RACK  
for profiles 403 y 401  
CREMAGLIERA PARETE  
con profili 403 e 401  
400/334

Al 3 m ∞ 401-403 €/m

4838/000  
ANCLAJE MULTILAMA  
support Multilama  
support Multilama  
supporto Multilama

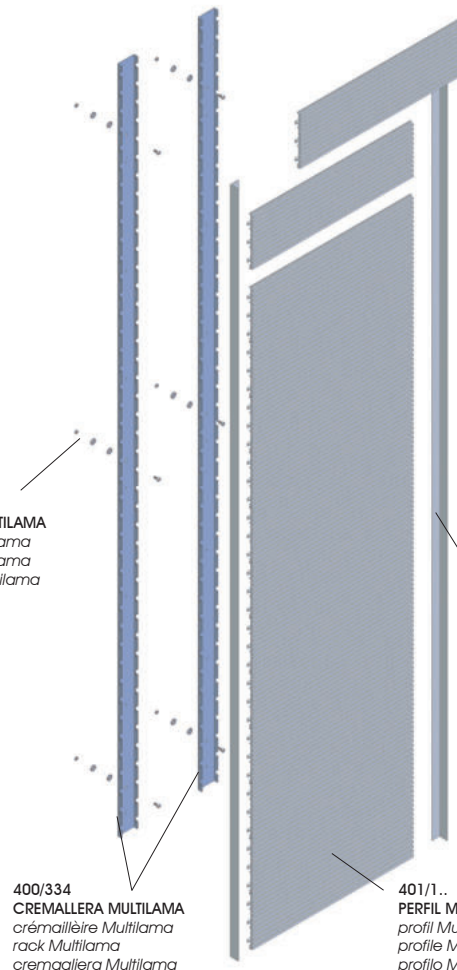

1651/1.. Ó  
1650/1..

400/334  
CREMALLERA MULTILAMA  
crémailleire Multilama  
rack Multilama  
cremagliera Multilama

401/1..  
PERFIL MULTILAMA  
profil Multilama  
profile Multilama  
profilo Multilama

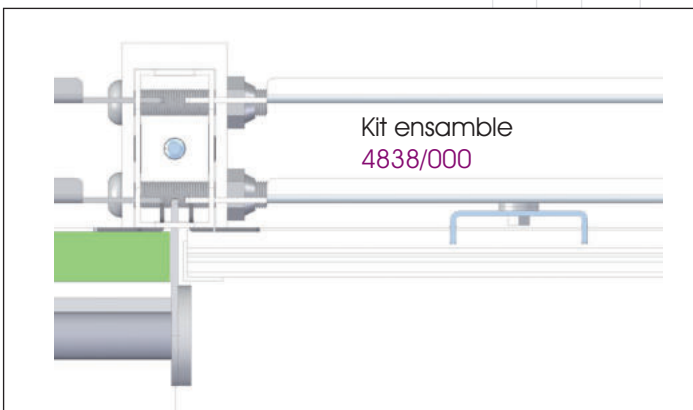

Kit ensamble  
4838/000

# SEPARADORES Y PORTAPRECIOS

## SEPARADORES CON DISPENSADOR DE PRODUCTO

SÉPARATEURS ET PUSSEURS  
DEVIDERS AND PUSHERS  
SEPARATORI E PUSHERS

PLÁSTICO  
PLASTIQUE  
PLASTIC  
PLASTICA

**09**



SEPARADOR FINAL IZQUIERDA ESTANTE 30 cm  
SÉPARATEUR EXTRÉMITÉ GAUCHE TABLETTE 30 cm  
LEFT SIDE SHELF DIVIDER SHELF 30 cm  
SEPARATORE ESTREMITÀ SINISTRA RIPIANO 30 cm  
**4833/009** transp.

plas 285mm €/u

○



SEPARADOR FINAL DERECHA ESTANTE 30 cm  
SÉPARATEUR EXTRÉMITÉ DROITE TABLETTE 30 cm  
RIGHT SIDE SHELF DIVIDER SHELF 30 cm  
SEPARATORE ESTREMITÀ DESTRA RIPIANO 30 cm  
**4834/009** transp.

plas 285mm €/u

○



SEPARADOR INTERMEDIO ESTANTE 30 cm  
SÉPARATEUR CENTRAL TABLETTE 30 cm  
CENTRE SHELF DIVIDER SHELF 30 cm  
SEPARATORE CENTRALE RIPIANO 30 cm  
**4835/009** transp.

plas 285mm €/u

○

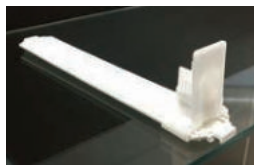

DISPENSADOR CON MUELLE ESTANTE 30 cm  
DISTRIBUTEUR À PRESSION DE PRODUIT TABLETTE 30 cm  
PUSHER SHELF 30 cm  
DISTRIButore A PRESSIONE RIPIANO 30 cm  
**4836/009**

plas 285mm €/u

○



GUÍA POSTERIOR ADHESIVA  
GUIDE DERRIÈRE ADHÉSIF  
ADESIVE BACK GUIDE  
GUIDA POSTERIORE ADESIVA  
**4832/109** transp.

plas 1m  
39 mm €/m

○

## PORTAPRECIOS PARA VIDRIO Y MADERA

TITULAIRE DE PRIX POUR VERRE ET BOIS  
PRICE HOLDER FOR GLASS AND WOOD  
DETENTORE DEL PREZZO PER VETRO E LEGNO

PLÁSTICO  
PLASTIQUE  
PLASTIC  
PLASTICA

**09**



GUÍA FRONTAL ESTANTE DE VIDRIO  
GUIDE FRONTAL ÉTAGÈRE EN VERRE  
FRONT GLASS SHELF GUIDE  
GUIDA FRONTALE RIPIANO IN VETRO  
**4830/109** transp.

plas 1m  
6-10 mm  
38 mm €/m

○

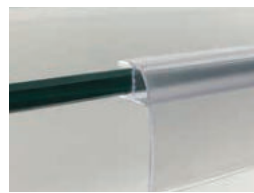

GUÍA FRONTAL ESTANTE DE VIDRIO  
GUIDE FRONTAL ÉTAGÈRE EN VERRE  
FRONT GLASS SHELF GUIDE  
GUIDA FRONTALE RIPIANO IN VETRO  
**4837/109** transp.

plas 1m  
6-10 mm  
28 mm €/m

○



GUÍA FRONTAL ESTANTE DE VIDRIO  
GUIDE FRONTAL ÉTAGÈRE EN VERRE  
FRONT GLASS SHELF GUIDE  
GUIDA FRONTALE RIPIANO IN VETRO  
**4848/109** transp.

plas 1m  
10 mm  
38 mm €/m

○

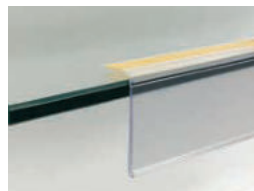

GUÍA FRONTAL ESTANTE DE VIDRIO/MADERA  
GUIDE FRONTAL ÉTAGÈRE EN VERRE/BOIS  
FRONT GLASS/WOOD SHELF GUIDE  
GUIDA FRONTALE RIPIANO IN VETRO/LEGNO  
**4849/109** transp.

plas 1m  
40 mm €/m

○



GUÍA FRONTAL ADHESIVA ESTANTE DE MADERA  
GUIDE FRONTAL ADHÉSIF ÉTAGÈRE EN BOIS  
ADHESIVE FRONT WOOD SHELF GUIDE  
GUIDA FRONTALE ADESIVA RIPIANO IN LEGNO  
PLÁSTICO TRANSPARENTE  
**4831/109** transp.

plas 1m  
26 mm €/m

○

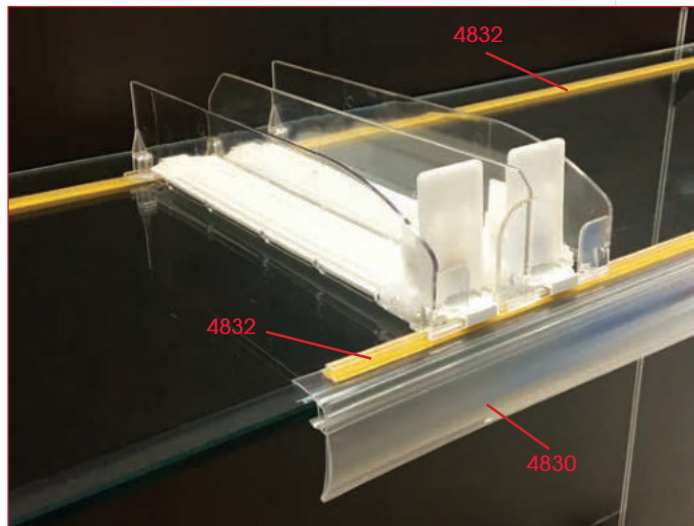
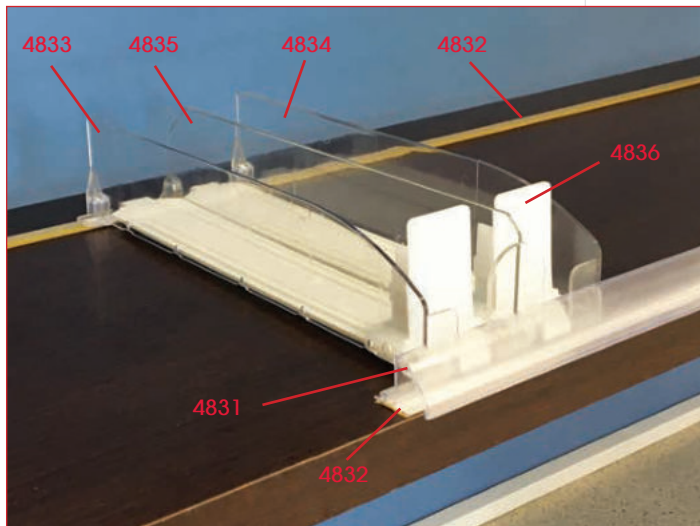

## KADÍ ELEKTRIC - PRIMO 25X25



## KADÍ ELEKTRIC - PRIMO 25X25



ESCANEA ESTE QR  
PARA VER TODAS  
LAS IMÁGENES DEL  
SISTEMA PRIMO



## KADÍ PRIMO ELEKTRIC

Ejemplos orientativos  
de distintas posibilidades,  
distribuciones y  
aplicaciones

# KADÍ ELEKTRIC - PRIMO 25X25

## EXPLOSIONADO GENERAL

### MONTAJE EN SERIE

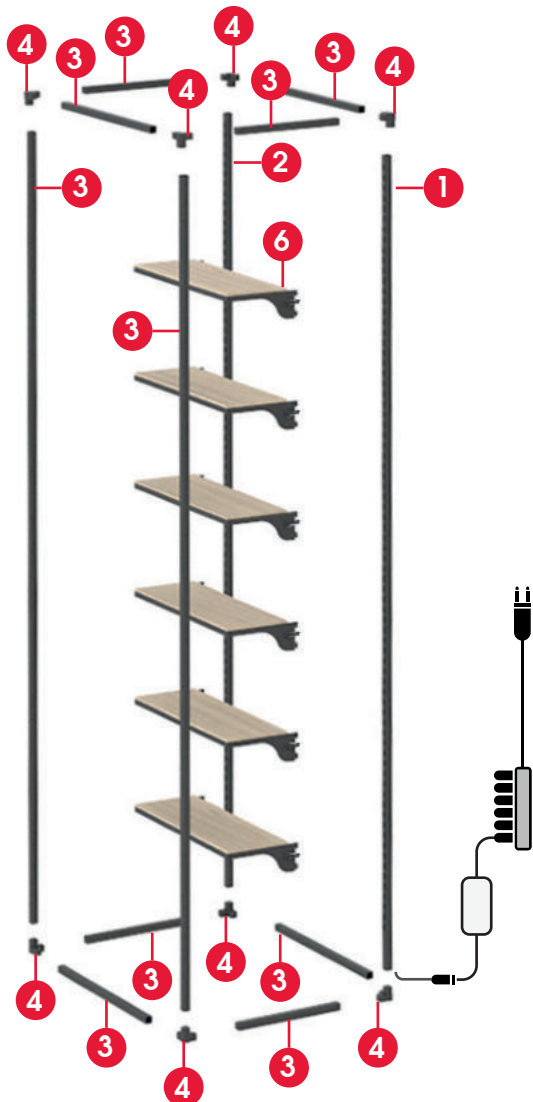

Colocar las cremalleras ELECTRIFICADAS EN LADO DERECHO de cada panel

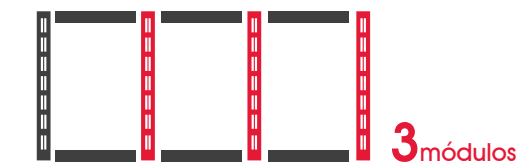
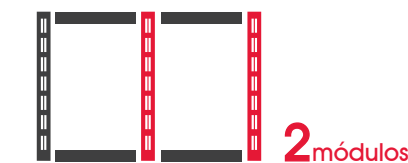

REF: 3960  
+ 3961 (CARRIL ELECTRIC)

Tubos electrificados

Solo los orificios izquierdos (representados en rojo) están electrificados.

REF: 3960

Tubos sin carril eléctrico

**1** Tubo primo electrificado - 1 cara

REF: 3960  
+3961



**2** Tubo primo troquelado 25x25

REF: 3960



**3** Tubo sin troquelar 25x25

REF: 3910



**4** Nudos



NUEVOS NUDOS

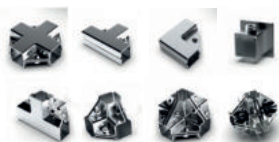

**5** Tapones

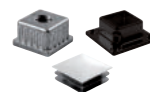

**6** Accesorios

- Personalizable:
- Estantes
  - Barras
  - Perroquets



# KADÍ ELEKTRIC - PRIMO 25X25

## MONTAJE ELECTRICO

HASTA X6 PANELES ▶ X1 

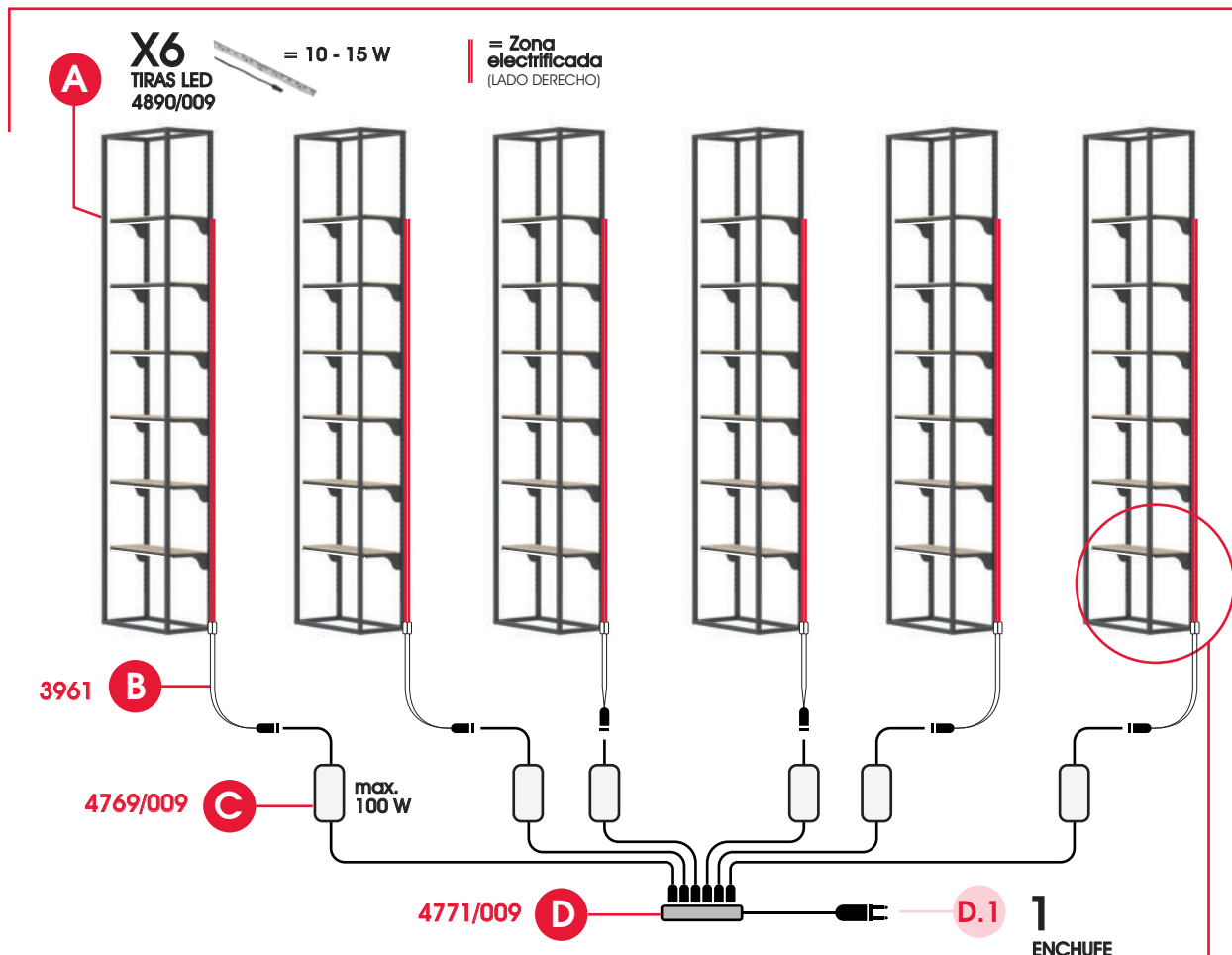

- A** Tiras LED  
(6 uds. por transformador)
- B** Cable con mini conector  
**LONGITUD DEL CABLE - 1M**
- C** Transformador  
(Cada panel debe llevar su transformador)
- D** Regleta de distribución
- D.1** Enchufe

- ES** • El carril electrificado lleva soldado el cable de conexión en la parte inferior. En el caso de prescindir de este conector Gesis, prestar atención a la polaridad de los cables para el correcto funcionamiento de la nueva conexión.
- FR** • La voie électrifiée porte le câble de connexion au conducteur en bas. En cas de suppression avec ce connecteur Gesis, faites attention à la polarité des câbles pour le bon fonctionnement de la nouvelle connexion.
- EN** • The electrified track carries the connection cable to the driver at the bottom. In the case of dispensing with this connector Gesis, pay attention to the polarity of the cables for the correct functioning of the new connection.
- IT** • Il binario elettrificato ha il cavo di connessione al driver saldato nella parte inferiore. Nel caso di prescindere del connettore Gesis, controllare la polarità dei cavi per assicurare il corretto funzionamento della nuova connessione.

**Cualquier manipulación invalida la garantía del fabricante**

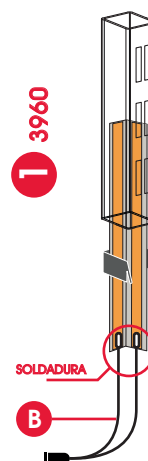

# KADÍ ELEKTRIC - PRIMO 25X25

## KADÍ PRIMO

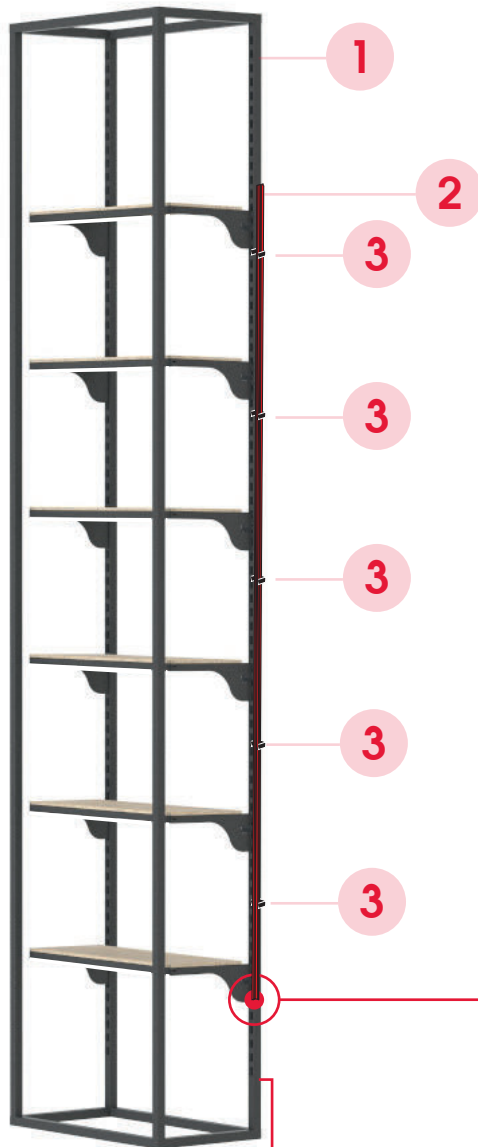

### 3 Grapas de plástico



- Las grapas deben ir repartidas de manera equitativa
- Colocar entre 4 y 8 grapas dependiendo de la medida.

- Tanto el tubo Primo ( 1 ) como el carril electrificado ( 2 ) se pueden adaptar a cualquier medida. Posibilidad de cortar.

### INICIO DEL CARRIL ELECTRIFICADO

### 4 Tope inferior

El tope inferior puede colocarse en cualquier orificio de la cremallera

Crea el inicio del carril electrificado

El carril queda apoyado al tope

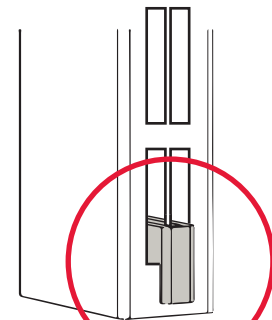

4

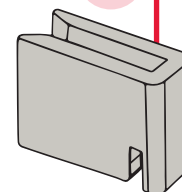

Crear un corte para la salida del cable eléctrico

Tener en cuenta el tipo de unión o nudo que se utilizará para que el orificio no interseccione con la pieza interior

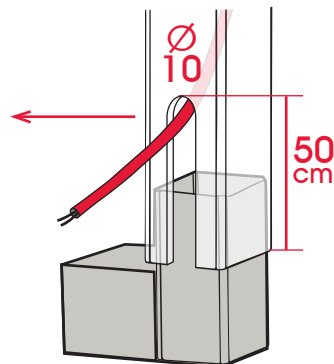

# KADÍ ELEKTRIC - PRIMO 25X25

## TUBO PRIMO ELECTRIFICADO

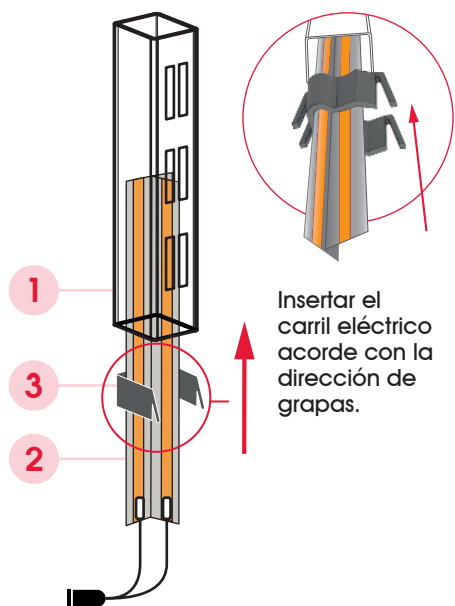

1 Tubo Primo 25x25x1,2



2 Carril eléctrico



3 Grapas de plástico



4 Tope inferior



## COLOCACIÓN DEL CONECTOR

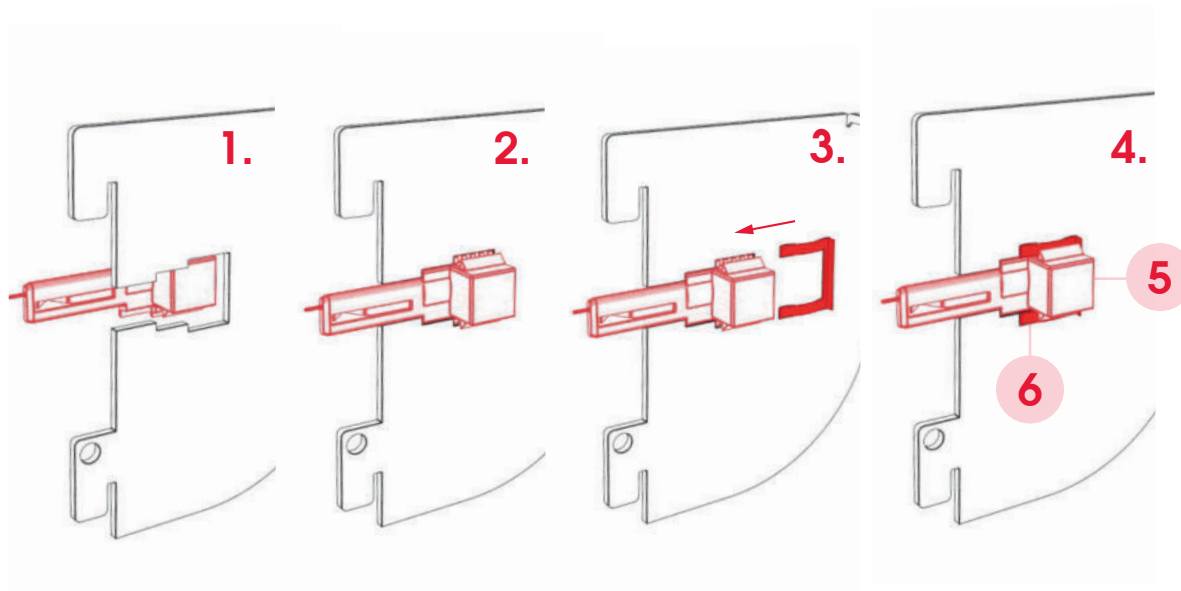

5 Conector

COMPATIBLE  
KADÍ PHARMA

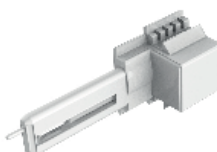

6 Grapas de fijación para el conector



# KADÍ ELEKTRIC - PRIMO 25X25

## ACCESORIOS PRIMO

-  Vidrio
-  Madera
-  Diferentes materiales y acabados

### ESTANTES

#### CARGA LIGERA



5890..



**NUEVO**

5891..



**NUEVO**

#### CARGA MEDIA



#### CARGA ALTA



5894..



**NUEVO**

5896..



**NUEVO**

5895..

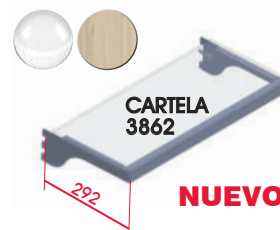

**NUEVO**

### BARRAS

#### CARGA LIGERA



#### CARGA MEDIA



5898..



**NUEVO**

5901..



**NUEVO**

5897..



**NUEVO**

### PORTA ROTULOS

#### CARGA LIGERA



5391



**NUEVO**

# KADÍ ELEKTRIC - PRIMO 25X25

## TABLA DE PESOS

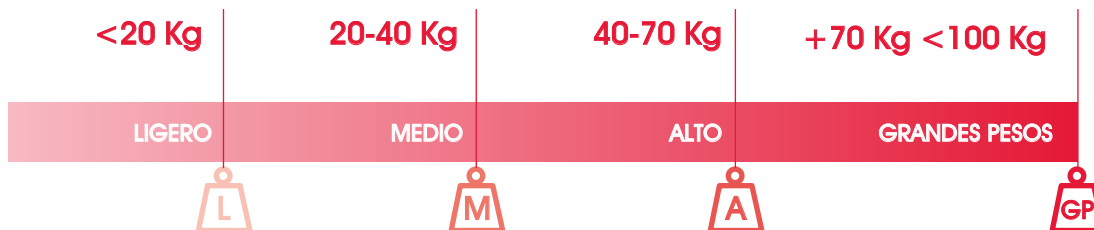

## COMPORTAMIENTO DE CARGA

● Puntos conflictivos de carga

\* La inclinación puede variar dependiendo del peso y la flexibilidad del aluminio.

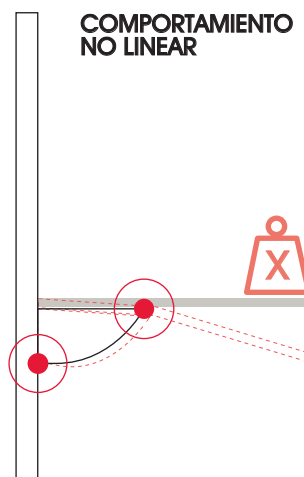
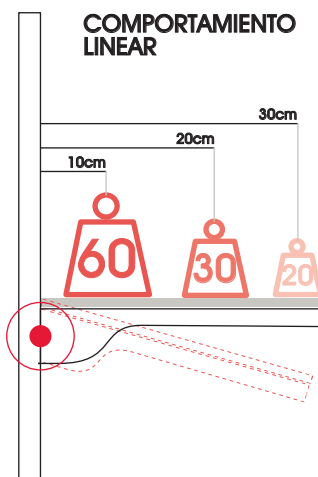

## AL ENCAJAR SE ENCIENDE

Con el sistema PLUG & PLAY el montaje de los módulos de carga resulta fácil, rápido y muy práctico, ya que solo encajando las cartelas a las cremalleras, el circuito eléctrico queda totalmente conectado y el LED encendido.

- FÁCIL
- RÁPIDO
- PRÁCTICO

## PLUG & PLAY



PLÁSTICO  
PLASTIQUE  
PLASTIC  
PLASTICA  
09

# KADÍ ELEKTRIC - PRIMO 25X25

## CREMALLERAS

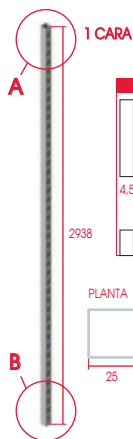

**TUBO 25X25X1.2 TROQUELADO**  
1 CARA  
TUBE PERFORATION SIMPLE  
1 CÔTÉ  
TUBE SINGLE SLOT CHANNEL  
1 SIDE  
TUBO PERFORAZIONE SINGOLA  
1 LATI  
3960/3.. 2938 MM

Fe 25x25x1,2mm €/u

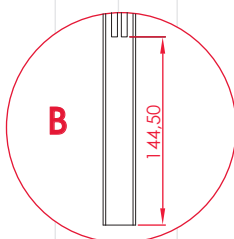
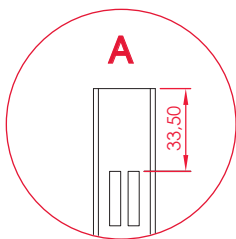
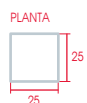
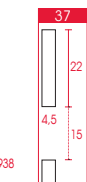

# KADÍ ELEKTRIC - PRIMO 25X25

## CONECTORES

### COMPATIBLE KADÍ PHARMA



+ incluye grapa



+ incluye grapa



CONNECTOR PLUG & PLAY,  
BLANCO  
CONNECTEUR PLUG & PLAY,  
BLANC  
CONNECTOR PLUG & PLAY,  
WHITE  
CONNETTORE PLUG & PLAY,  
BIANCO  
**84864/00B**

Pla ⚡ 24V max.3A €/u  
CE IP20

CONNECTOR PLUG & PLAY,  
NEGRO  
CONNECTEUR PLUG & PLAY,  
NOIR  
CONNECTOR PLUG & PLAY,  
BLACK  
CONNETTORE PLUG & PLAY,  
NERO  
**84864/00N**

Pla ⚡ 24V max.3A €/u  
CE IP20

## KIT CARRIL ELECTRIFICADO

### KIT 1CARA



**KIT PERFIL DE ALUMINIO ELECTRIFICADO A UNA CARA CON GRAPAS DE PLÁSTICO**  
KIT PROFILÉ ALUMINIUM ÉLECTRIFIÉ D'UN CÔTÉ AVEC DES AGRAFES EN PLASTIQUE  
KIT ALUMINUM PROFILE ELECTRIFIED ON ONE SIDE WITH PLASTIC STAPLES  
KIT PROFILO IN ALLUMINIO ELETRIFICATO SU UN LATO CON GRAFFE IN PLASTICA  
3961/241 240 CM  
3961/181 180 CM  
3961/121 120 CM

Al 22x13 mm €/u

### Nº COMPONENTES/MEDIDA

MEDIDA	240 cm	180 cm	120 cm
Grapas	X8 uds	X6 uds	X4 uds
Carril electrificado	1 carril de 240	1 carril de 180	1 carril de 120
Tope inferior	X1 ud	X1 ud	X1 ud
Conector Gesis	X1 ud	X1 ud	X1 ud

# KADÍ ELEKTRIC - PRIMO 25X25

## MINI-CONECTORES



**CABLE MINI PLUG - ABIERTO 24V**  
 CABLE MINI PLUG - OVERTE 24V  
 CABLE MINI PLUG - OPEN ENDED 24V  
 CAVO MINI PLUG - APERTO 24V  
**4888/009**

Pla	400 mm	€/u
	⚡ 24V 2,5A	



**CABLE MINI PLUG - W PLUG 24V**  
 CABLE MINI PLUG - W PLUG 24V  
 CABLE MINI PLUG - W PLUG 24V  
 CAVO MINI PLUG - W PLUG 24V  
**\*4889/009**

Pla	400 mm	€/u
	⚡ 24V 2,5A	

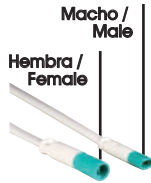

**CABLE CON MINI - CONECTORES 24V**  
 CABLE + MINI PLUG - 24V  
 CABLE + MINI PLUG - 24V  
 CAVO + MINI PLUG - 24V  
**\*4767/009 1M**  
**\*4768/009 2M**

Pla	1/2M	€/u
	⚡ 24V 2,5A	



**ENCHUFE + CABLE + MINI CONECTOR 230V**  
 FICHE + CABLE + MINI-PLUG 230V  
 EURO-PLUG + CABLE + MINI-PLUG 230V  
 SPINA CORRENTE + CAVO + MINI-PLUG 230V  
**\*4773/009**

Pla	3M	€/u
	⚡ 230V 2,5A	

ANTIGUO



NUEVO



El nuevo conector substituirá al antiguo en todas las conexiones una vez agotadas las existencias del antiguo.

## DRIVER



**DRIVER + 6 SALIDAS CON MINI-CONECTORES 24V**  
 DRIVER + DISTRIBUTEUR 6 SORTIES AVEC MINI-PLUG 24V  
 DRIVER + DISTRIBUTOR 6 WAYS-BLOCK WITH MINI-PLUG 24V  
 DRIVER + DISTRIBUTORE 6 USCITE CON MINI-PLUG 24V  
**\*4770/009**

Pla	3 m	⚡ 100 W	€/u
		230V > 24V	

Hembra / Female



**DRIVER + 6 SALIDAS CON MINI - CONECTORES 24V**  
 DRIVER + DISTRIBUTEUR 6 SORTIES AVEC MINI-PLUG 24V  
 DRIVER + DISTRIBUTOR 6 WAYS-BLOCK WITH MINI-PLUG 24V  
 DRIVER + DISTRIBUTORE 6 USCITE CON MINI-PLUG 24V  
**\*4769/009**

Pla	1/2 M	⚡ 24 V	€/u
		2,5 A	

# KADÍ ELEKTRIC - PRIMO 25X25

## MINI-CONECTORES

\* Hasta agotar existencias



**ENCHUFE + CABLE + DISTRIBUIDOR 6 SALIDAS CON MINI-CONECTORES 230V**  
 FICHE + CABLE + DISTRIBUTEUR 6 SORTIES AVEC MINI-PLUG 230V  
 EURO-PLUG + CABLE + DISTRIBUTOR 6 WAYS-BLOCK WITH MINI-PLUG 230V  
 SPINA CORRENTE + CAVO + DISTRIBUTORE 6 USCITE CON MINI-PLUG 230V  
**\*4771/009**

Pla	3M	€/u
	⚡ 230V 2,5A	



**CABLE CON MINI-CONECTORES 230V**  
 CABLE + MINI PLUG - 230V  
 CABLE + MINI PLUG - 230V  
 CAVO + MINI PLUG - 230V  
**\*4772/009**

Pla	3M	€/u
	⚡ 230V 2,5A	

## ACCESORIO CONECTOR

### KIT LUZ CENITAL



**Cartela X1**  
**Conector X1**

**KIT ACCESORIO CONECTOR DE PLÁSTICO PARA ILUMINACIÓN CENITAL**  
 KIT D'ACCESSOIRES DE CONNECTEUR EN PLASTIQUE POUR ÉCLAIRAGE AÉRIEN  
 PLASTIC CONNECTOR ACCESSORY KIT FOR OVERHEAD LIGHTING  
 KIT ACCESSORI CONNETTORE IN PLASTICA PER ILLUMINAZIONE AMBIENTALE  
**5330/010**

Pla		€/u
-----	--	-----

### Ejemplo de aplicación:

La pieza actúa como soporte del conector el cual da conexión a la luz superior, permitiendo iluminar los plafones superiores de la estructura.

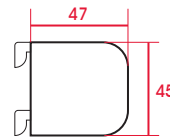

**DRIVER + 6 SALIDAS CON MINI-CONECTORES 24V**  
 DRIVER + DISTRIBUTEUR 6 SORTIES AVEC MINI-PLUG 24V  
 DRIVER + DISTRIBUTOR 6 WAYS-BLOCK WITH MINI-PLUG 24V  
 DRIVER + DISTRIBUTORE 6 USCITE CON MINI-PLUG 24V  
**\*4770/009**

Pla	3 m	⚡ 100 W	€/u
		230V > 24V	

Hembra / Female



**DRIVER + 6 SALIDAS CON MINI - CONECTORES 24V**  
 DRIVER + DISTRIBUTEUR 6 SORTIES AVEC MINI-PLUG 24V  
 DRIVER + DISTRIBUTOR 6 WAYS-BLOCK WITH MINI-PLUG 24V  
 DRIVER + DISTRIBUTORE 6 USCITE CON MINI-PLUG 24V  
**\*4769/009**

Pla	1/2 M	⚡ 24 V	€/u
		2,5 A	

**DRIVER 100W, 24V / CONECTOR HEMBRA CONDUCTEUR 100W, 24V / CONNECTEUR FEMELLE DRIVER 100W, 24V / FEMALE CONNECTOR DRIVER 100W, 24V / CONNETTORE FEMMINA**  
**6010/009**

6 SALIDAS

Pla	⚡ 24V 100W	€/u
	15cm	

PLÁSTICO PLASTIQUE PLASTIC PLASTICA  
09

---

**CABLE CON MINI-CONECTORES 230V**  
 CABLE + MINI PLUG - 230V  
 CABLE + MINI PLUG - 230V  
 CAVO + MINI PLUG - 230V  
**6015/00B**

Pla	3 m	⚡ 230 V	€/u
		2,5 A	

!

## NUEVO

# KADI - PRIMO NUDOS PRESIÓN

CR. BRLO CH. POI BR. CHR CR. LLC.	BLANCO BLANC WHITE BIANCO	NEGRO NOIR BLACK NERO	COLOR COULEUR COLOR COLORE
32	OB	ON	OP



**NUDO 3 VIAS**  
JOINT À 3 VOIES  
3 WAY JOINT  
GIUNTO 3 VIE  
3900/0..

Zn	25x25 mm	€/u
----	----------	-----

<input type="radio"/>	<input type="radio"/>	<input type="radio"/>
-----------------------	-----------------------	-----------------------



**NUDO 3 VIAS + ROSCAMI10**  
JOINT À 3 VOIES + TROU M10  
3 WAY JOINT + M10 HOLE  
GIUNTO 3 VIE + FORO M10  
3901/0..

Zn	25x25mm	€/u
----	---------	-----

<input type="radio"/>	<input type="radio"/>	<input type="radio"/>
-----------------------	-----------------------	-----------------------



**NUDO 4 VIAS**  
JOINT À 4 VOIES  
4 WAY JOINT  
GIUNTO 4 VIE  
3902/0..

Zn	25x25 mm	€/u
----	----------	-----

<input type="radio"/>	<input type="radio"/>	<input type="radio"/>
-----------------------	-----------------------	-----------------------



**NUDO 4 VIAS + ROSCAMI10**  
JOINT À 4 VOIES + TROU M10  
4 WAY JOINT + M10 HOLE  
GIUNTO 4 VIE + FORO M10  
3903/0..

Zn	25x25mm M10	€/u
----	-------------	-----

<input type="radio"/>	<input type="radio"/>	<input type="radio"/>
-----------------------	-----------------------	-----------------------



**NUDO 5 VIAS**  
JOINT À 5 VOIES  
5 WAY JOINT  
GIUNTO 5 VIE  
3904/0..

Zn	25x25mm	€/u
----	---------	-----

<input type="radio"/>	<input type="radio"/>	<input type="radio"/>
-----------------------	-----------------------	-----------------------



**NUDO 3 VIAS "T"**  
JOINT À 3 VOIES "T"  
"T" 3 WAY JOINT  
GIUNTO 3 VIE "T"  
3907/0..

Zn	20x20mm	€/u
----	---------	-----

<input type="radio"/>	<input type="radio"/>	<input type="radio"/>
-----------------------	-----------------------	-----------------------



**NUDO 2 VIAS**  
JOINT À 2 VOIES  
2 WAY JOINT  
GIUNTO 2 VIE  
3905/0..

Zn	25x25mm	€/u
----	---------	-----

<input type="radio"/>	<input type="radio"/>	<input type="radio"/>
-----------------------	-----------------------	-----------------------

# ACCESORIOS PARA TUBO 25X25

CR.NEGRO

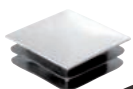

PL.NEGRO

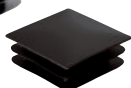

**TAPÓN TUBO 25X25**  
EMBOUT  
END-CAP  
COPRITESTA  
3911/032

Fe	25x25 mm	€/u
----	----------	-----

<input type="radio"/>	<input type="radio"/>	
-----------------------	-----------------------	--

PL.NEGRO



**TAPÓN M10 TUBO 20X20**  
EMBOUT with M10 hole  
EMBOUT avec m10 trou  
COPRITESTA con foro M10  
3912/000

Zn	25x25 mm M10	€/u
----	--------------	-----

<input type="radio"/>		
-----------------------	--	--



**ANCLAJE TUBO 25X25**  
FIXATION TUBE  
TUBO FIXING  
FISSAGGIO TUBO  
3929/032

Zn	25x25 mm	€/u
----	----------	-----

<input type="radio"/>	<input type="radio"/>	<input type="radio"/>
-----------------------	-----------------------	-----------------------

# KADI - PRIMO NUDOS BRIDA

CR. BRLO CH. POI BR. CHR CR. LLC.	BLANCO BLANC WHITE BIANCO	NEGRO NOIR BLACK NERO	COLOR COULEUR COLOR COLORE
32	OB	ON	OP



**NUDO 3 VIAS**  
JOINT À 3 VOIES  
3 WAY JOINT  
GIUNTO 3 VIE  
3980/0..

Zn	25x25 mm	€/u
----	----------	-----

<input type="radio"/>	<input type="radio"/>	<input type="radio"/>
-----------------------	-----------------------	-----------------------



**NUDO 4 VIAS**  
JOINT À 4 VOIES  
4 WAY JOINT  
GIUNTO 4 VIE  
3982/0..

Zn	25x25 mm	€/u
----	----------	-----

<input type="radio"/>	<input type="radio"/>	<input type="radio"/>
-----------------------	-----------------------	-----------------------



**NUDO 4 VIAS**  
JOINT À 4 VOIES  
4 WAY JOINT  
GIUNTO 4 VIE  
3988/0..

Zn	25x25 mm	€/u
----	----------	-----

<input type="radio"/>	<input type="radio"/>	<input type="radio"/>
-----------------------	-----------------------	-----------------------



**NUDO 5 VIAS**  
JOINT À 5 VOIES  
5 WAY JOINT  
GIUNTO 5 VIE  
3984/0..

Zn	25x25mm	€/u
----	---------	-----

<input type="radio"/>	<input type="radio"/>	<input type="radio"/>
-----------------------	-----------------------	-----------------------



**NUDO 6 VIAS**  
JOINT À 6 VOIES  
6 WAY JOINT  
GIUNTO 6 VIE  
3986/0..

Zn	25x25mm	€/u
----	---------	-----

<input type="radio"/>	<input type="radio"/>	<input type="radio"/>
-----------------------	-----------------------	-----------------------



**NUDO 3 VIAS "T"**  
JOINT À 3 VOIES "T"  
"T" 3 WAY JOINT  
GIUNTO 3 VIE "T"  
3987/0..

Zn	20x20mm	€/u
----	---------	-----

<input type="radio"/>	<input type="radio"/>	<input type="radio"/>
-----------------------	-----------------------	-----------------------



**NUDO 2 VIAS**  
JOINT À 2 VOIES  
2 WAY JOINT  
GIUNTO 2 VIE  
3985/0..

Zn	25x25mm	€/u
----	---------	-----

<input type="radio"/>	<input type="radio"/>	<input type="radio"/>
-----------------------	-----------------------	-----------------------



**TUBO 25X25 mm**  
TUBE 25X25 mm  
TUBE 25x25 mm  
TUBO 25x25 mm  
3989/0..

Fe	25x25x1,2	€/u
----	-----------	-----

<input type="radio"/>	<input type="radio"/>	<input type="radio"/>
-----------------------	-----------------------	-----------------------

**! NUEVO**

# TUBO 25X25



**TUBO 25X25 mm**  
TUBE 25X25 mm  
TUBE 25x25 mm  
TUBO 25x25 mm  
3910/3..

Fe	L 3 m	25x25x1,2	€/u
----	-------	-----------	-----

<input type="radio"/>	<input type="radio"/>	<input type="radio"/>
-----------------------	-----------------------	-----------------------



\*  MADERA NO INCLUIDA

# KADÍ ELEKTRIC - PRIMO 25X25

## PORTA RÓTULOS 5391/1..

COMPATIBLE  
KADÍ PRIMO



MATERIAL RÓTULO \*  NO INCLUIDO

CARTELA CON CONECTOR  
PARA LETREROS CON  
ILUMINACIÓN  
5391/0..

SIN MONTAJE

Placard avec  
connecteur pour  
enseignes lumineuses.  
Placard with connector  
for illuminated signs.  
Cartello con connettore  
per insegne luminose.

1M máx.  
7 cm

Fe  72 mm medida útil

€/u

BLANCO BLANC WHITE BIANCO	NEGRO NOR BLACK NERO	COLOR COULEUR COLOR COLORE
OB	ON	OP

# KADÍ ELEKTRIC - PRIMO 25X25

## ESTANTE MADERA 5896/1..

COMPATIBLE  
KADÍ PRIMO



MADERA \*  NO INCLUIDA

ESTANTE DE MADERA  
CON ILUMINACIÓN  
FRONTAL EMPOTRADA  
Y PERFIL DE ALUMINIO  
5896/1..

SIN MONTAJE

Étagère en bois avec  
éclairage zenithal monté sur  
l'étagère  
Wooden shelf with zenithal  
lighting mounted on the shelf  
Ripiano legno con  
illuminazione zenitale  
impotrata nel ripiano

1M máx.  
28 cm

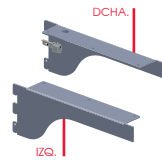

€/u

PL. M ALU. M ALU. M ALL. NAT.	BLANCO BLANC WHITE BIANCO	NEGRO NOR BLACK NERO	COLOR COULEUR COLOR COLORE
01	OB	ON	OP



Kit 2 cartelas:  
DERECHA (con  
conector) +  
IZQUIERDA

KIT CARTELAS ESTANTE MADERA  
CON ILUMINACIÓN  
KIT SUPPORTS BOIS ILLUMINATION  
WOOD LIGHTING BRACKETS KIT  
KIT MENSOLE LEGNO  
ILLUMINAZIONE  
5381/0..

Fe  4890  282 mm medida útil

o o o



Medidas  
mecanizado  
16 x 6.8 mm

KIT PERFIL ALUMINIO CON  
DIFUSOR  
KIT PROFIL EN ALUMINIUM  
AVEC DIFFUSEUR  
KIT PROFILO IN ALLUMINIO  
CON DIFFUSORE  
3971/1..

Al  2M 18x9mm €/m

o

4881/301  
Medidas  
mecanizado  
18 x 6.2 mm





PERFIL ALUMINIO,  
DIFUSOR DE PLÁSTICO  
MATE, TAPA FINAL, 2 U.

PROFIL EN ALUMINIUM,  
DIFFUSEUR EN PLASTIQUE  
MAT, EMBOUT, 2 U.  
ALUMINIUM PROFILE, MATT  
PLASTIC DIFFUSOR, END CAP,  
2 U.

PROFILO DI ALLUMINIO,  
DIFUSORE PLASTICO OPACO,  
TAPPO DI APRIFESTA, 2 U.

Al  3 m 24x7 €/u

Pla  2 m  4882 €/u

Pla  4892-4894 €/u

Pla  4881 €/u



4881/301  
4882/159  
4883/009

o o o



126 diodos (20λ);  
cortable cada  
5.5 cm  
Cable, fil. wire,  
cavo: 40cm  
Ancho 8 mm  
flexible y con  
cinta adhesiva  
fleible and  
self-adhesive

LED CON MINI-CONECTOR  
24V  
BANDE LED AVEC MINI-PLUG  
24V  
LED STRIP WITH MINI-PLUG  
24V  
STRIACIA LED CON  
MINI-PLUG 24V  
4890/009

Pla  1 m  5000 K €/u

 CRI > 90  9,6 W 24V

o

o

o

o

o

o

o

# KADÍ ELEKTRIC - PRIMO 25X25

## ESTANTE VIDRIO 5895/1..

**ESTANTE DE VIDRIO CON ILUMINACIÓN FRONTAL 5895/1.. MONTADO**

Étagère en verre avec éclairage avant  
Glass shelf with front lighting  
Ripiano vetro con illuminazione frontale

1M máx. 29 cm

VIDRIO \* NO INCLUIDO

PL. M. ALU. M. ALL. NAT	BLANCO WHITE BIANCO	NEGRO NOIR BLACK NERO	COLOR COULEUR COLOR COLORE
01	0B	0N	0P

PARA MADERA O VIDRIO

# KADÍ ELEKTRIC - PRIMO 25X25

## ESTANTE VIDRIO 5894/1..

**ESTANTE DE VIDRIO CON ILUMINACIÓN CENTRAL FRONTAL 5894/1.. MONTADO**

Étagère en verre avec éclairage zenithal frontal  
Glass shelf with frontal zenithal lighting  
Ripiano di vetro con illuminazione zenitale frontale

1M máx. 27 cm

VIDRIO \* NO INCLUIDO

PLÁSTICO PLASTIQUE PLASTIC PLASTICA	BLANCO WHITE BIANCO	NEGRO NOIR BLACK NERO	COLOR COULEUR COLOR COLORE
09	0B	0N	0P

PARA MADERA O VIDRIO

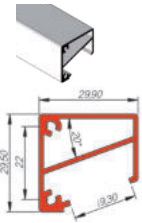

**PERFIL ALUMINIO PROFIL EN ALUMINIUM ALUMINIUM PROFILE PROFILO DI ALUMINIO 4744/1..**

Al	5 m	30x30	€/m
Ⓞ	84602		

Pla	2 m	Ⓞ <th>4744</th> <th>€/m</th>	4744	€/m



**DIFUSOR PLÁSTICO MATE DIFFUSEUR EN PLASTIQUE MAT MATT PLASTIC DIFFUSOR DIFUSORE PLASTICO OPACO 84602/109**

PLÁSTICO PLASTIQUE PLASTIC PLASTICA	09

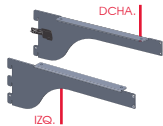

**KIT CARTELAS ESTANTE VIDRIO CON ILUMINACIÓN KIT SUPPORTS VERRE ILLUMINATION GLASS LIGHTING BRACKETS KIT KIT MENSOLE VETRO ILLUMINAZIONE 3862/0..**

Fe	Ⓞ <th>4744-2556-4890</th> <th>€/u</th>	4744-2556-4890	€/u

292 mm medida útil

Cada cartela tiene 2 tornillos para usar 1 perfil 4744  
Kit 2 cartelas: DERECHA (con conector) + IZQUIERDA



126 diodos (20λ); cortable cada 5.5 cm  
Cable, fil. wire, cavo: 26cm Ancho 8mm  
flexible y con cinta adhesiva flexible and self-adhesive

**LED CON MINI-CONECTOR 24V BANDE LED AVEC MINI-PLUG 24V LED STRIP WITH MINI-PLUG 24V STRIACIA LED CON MINI-PLUG 24V 4890/109**

Pla	1 m	⚡	5000 K	€/u

Ⓞ CRI>90 Ⓞ 9,6 W 24V

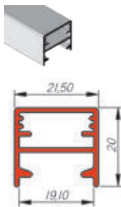

**PERFIL ALUMINIO PROFIL EN ALUMINIUM ALUMINIUM PROFILE PROFILO DI ALUMINIO 4748/1..**

Al	6 m	21,5x20	€/m
Ⓞ	4893		

Pla	Ⓞ <th>4892 - 4894</th> <th>€/m</th>	4892 - 4894	€/m

2 m



**DIFUSOR PLÁSTICO MATE DIFFUSEUR EN PLASTIQUE MAT MATT PLASTIC DIFFUSOR DIFUSORE PLASTICO OPACO 4893/109**

Pla	Ⓞ <th>4892 - 4894</th> <th>€/m</th>	4892 - 4894	€/m

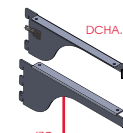

**KIT CARTELAS ESTANTE VIDRIO CON ILUMINACIÓN KIT SUPPORTS VERRE ILLUMINATION GLASS LIGHTING BRACKETS KIT KIT MENSOLE VETRO ILLUMINAZIONE 5385/0..**

Fe	Ⓞ <th>4744-2556-4890</th> <th>€/u</th>	4744-2556-4890	€/u

270 mm medida útil

Kit 2 cartelas: DERECHA (con conector) + IZQUIERDA



126 diodos (20λ); cortable cada 5.5 cm  
Cable, fil. wire, cavo: 26cm Ancho 8mm  
flexible y con cinta adhesiva flexible and self-adhesive

**LED CON MINI-CONECTOR 24V BANDE LED AVEC MINI-PLUG 24V LED STRIP WITH MINI-PLUG 24V STRIACIA LED CON MINI-PLUG 24V 4890/109**

Pla	1 m	⚡	5000 K	€/u

Ⓞ CRI>90 Ⓞ 9,6 W 24V



**VENTOSA TRANSPARENTE VENTOUSE SUCITON VENTOSA 2556/009**

Pla	Ⓞ <th>14 mm</th> <th>Ⓞ <th>4880</th> <th>€/u</th> </th>	14 mm	Ⓞ <th>4880</th> <th>€/u</th>	4880	€/u

# KADÍ ELEKTRIC - PRIMO 25X25

## ESTANTE VIDRIO 5890/1..

\*  Recomendamos usar vidrios segurizados o laminados. (NO INCLUIDO)

PL. M	BLANCO	NEGRO	COLOR
ALU. M	BLANC	NOIR	COULEUR
ALU. M	WHITE	BLACK	COLOR
ALL. NAT	BIANCO	NERO	COLOR
01	0B	0N	0P



ESTANTE DE VIDRIO RETROILUMINADO 5890/1..

**MONTADO**

Étagère en verre extra claire rétro-éclairé  
Blacklit optical glass shelf  
Ripiano vetro extralight retroilluminato

1M máx.  30 cm

**VIDRIO \* NO INCLUIDO** 

€/u

# KADÍ ELEKTRIC - PRIMO 25X25

## ESTANTE VIDRIO 6891/1..

PL. M	BLANCO	NEGRO	COLOR
ALU. M	BLANC	NOIR	COULEUR
ALU. M	WHITE	BLACK	COLOR
ALL. NAT	BIANCO	NERO	COLOR
01	0B	0N	0P



ESTANTE DE VIDRIO CON ILUMINACIÓN FRONTAL 5891/1..

**MONTADO**

Étagère en verre avec éclairage zénithal frontal  
Glass shelf with frontal zenithal lighting  
Ripiano di vetro con illuminazione zenitale frontale

1M máx.  30 cm

**VIDRIO \* NO INCLUIDO** 



€/u



Junta goma incluida  
joint en caoutchouc inclus  
rubber gasket included  
giunta di gomma inclusa

PERFIL ALUMINIO PROFIL LAME D'ALUMINIUM ALUMINIUM SLATWALL PROFILE PROFILO DOGATO ALLUMINIO

362/1...

Al	 5 m	 6-8mm	€/m
	⊙ 361/109		

o o o o



PERFIL ALUMINIO PROFIL EN ALUMINIUM ALUMINIUM PROFILE PROFILO DI ALLUMINIO

4892/1..

Al	 5 m	32x11,2	€/m
	⊙ 4893 -4894		

o o o o



Placa LED

DIFUSOR DE PLÁSTICO MATE DIFFUSEUR EN PLASTIQUE MAT MATT PLASTIC DIFFUSOR DIFUSORE PLASTICO OPACO

4893/109

Pla	⊙ 4892 -4894	€/m
	2 m	

o

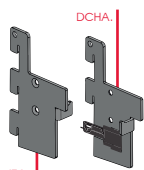

IZQ.

Con perfil 362  
Kit 2 cartelas:  
DERECHA (con  
conector) +  
IZQUIERDA

KIT CARTELAS ESTANTE VIDRIO CON ILUMINACIÓN KIT SUPPORTS VERRE ILLUMINATION GLASS LIGHTING BRACKETS KIT KIT MENSOLE VETRO ILLUMINAZIONE

5384/0..

Fe	⊙ 362 - 4890	€/u
	53 mm medida útil	

o o o o



KIT TAPAS FINALES LATERALES COUVERTURE LATÉRALE FINALE LATERAL END CAP COPERTURA LATERALE FINALE

4894/0..

Pla	32x11,2 mm	€/u
	⊙ 4892	

o o



126 diodos (20λ);  
cortable cada  
5,5 cm  
Cable, fil. wire,  
cavo: 26cm  
Ancho 8mm

flexible y con  
cinta adhesiva  
fleible and  
self-adhesive

LED CON MINI-CONECTOR 24V BANDE LED AVEC MINI-PLUG 24V LED STRIP WITH MINI-PLUG 24V STRIACIA LED CON MINI-PLUG 24V

4890/109

Pla	 1 m	$\zeta$ 5000 K	€/u
	⊙ CRI>90	⊙ 9,6 W 24V	

PLÁSTICO PLASTIQUE PLASTICA 09

o



MINI PLUG

flexible y con cinta  
adhesiva  
fleible and  
self-adhesive

30 CM CABLE PLANO ADHESIVO 30 CM CÂBLE ADHÉSIF PLAT 30 CM FLAT ADHESIVE CABLE 30 CM CAVO ADESIVO PIATTO

4895/009

Pla	 300 mm	€/u
	$\zeta$ 24V-2,5A	

o

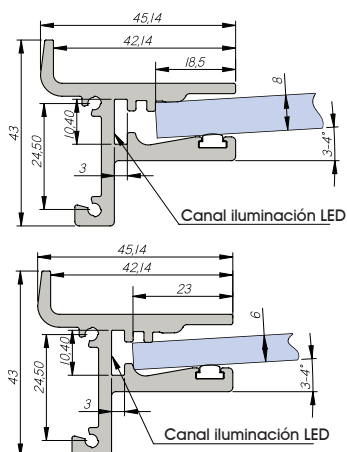

ES • MÁXIMA MEDIDA ESTANTE RECOMENDADA: 100 X 30 CM.

FR • Maximum recommended shelf size: 100 x 30 cm.

IT • Dimensione massima raccomandata dello scaffale: 100 x 30 cm.

EN • Taille maximale de l'étagère recommandée: 100 x 30 cm.

\*  MADERA NO INCLUIDA

# KADÍ ELEKTRIC - PRIMO 25X25

## PENDERIE 5897/1..

KIT compuesto por:  
- Cartelas Ref.5382  
-Tubo rectangular Ref.4900/12B  
-LED de 1m



VIDRIO / MADERA NO INCLUIDO



ESTANTE + BARRA DE CUELGUE LATERAL CON ILUMINACIÓN Y PROTECCIÓN PLÁSTICA SUPERIOR 5897/1..

### MONTADO

Tablette + barre de suspension laterale avec éclairage  
Shelf + side hanging bar with lighting  
Mensola + barra appendiabiti laterale con illuminazione

1M máx. 29 cm

PARA MADERA O VIDRIO



PLÁSTICO PLASTIQUE PLASTICA	BLANCO BLANC WHITE	NEGRO NOIR BLACK NERO	COLOR COULEUR COLOR COLORE
09	0B	0N	0P

€/u

# KADÍ ELEKTRIC - PRIMO 25X25

## BARRA CUELGUE LAT.5898/1..

KIT compuesto por:  
- Cartelas Ref.5383  
-Tubo rectangular Ref.4900/12B  
-LED de 1m



BARRA DE CUELGUE LATERAL CON ILUMINACIÓN Y PROTECCIÓN PLÁSTICA SUPERIOR 5898/1..

### MONTADO

Barre de suspension laterale avec éclairage  
Side hanger bar with lighting  
Barra appendiabiti laterale con illuminazione

1M máx. 29 cm

€/u

PL M ALU. M ALL. NAT	BLANCO BLANC WHITE	NEGRO NOIR BLACK NERO	COLOR COULEUR COLOR COLORE
01	0B	0N	0P

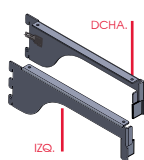

DCHA.

IZQ.

Kit 2 cartelas: DERECHA (con conector) + IZQUIERDA

KIT CARTELAS BARRA ACCESORIOS  
KIT SUPPORT BARRE ACCESSOIRES  
KIT BRACKET FOR ACCESSORIES ROD  
KIT MENSOLA TUBO PORTA-ACCESSORI 5382/00.

Fe	⊙ 4900	€/u
	290 mm medida útil	

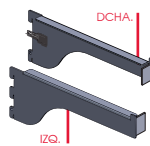

DCHA.

IZQ.

Kit 2 cartelas: DERECHA (con conector) + IZQUIERDA

KIT CARTELAS BARRA ACCESORIOS  
KIT SUPPORT BARRE ACCESSOIRES  
KIT BRACKET FOR ACCESSORIES ROD  
KIT MENSOLA TUBO PORTA-ACCESSORI 5383/00.

Fe	⊙ 4900	€/u
	290 mm medida útil	

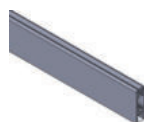

LED no incluido. LED recomendado de 5mm de ancho. Incluye perfil de plástico superior y difusor interior.

TUBO RECTANGULAR PARA ILUMINACIÓN 30X10MM CON PLETINA DE REFUERZO  
KIT TUBE RECTANGULAIRE POUR ECLAIRAGE 30X10MM AVEC PLAQUE DE RENFORT  
KIT RECTANGULAR TUBE FOR LIGHTING 30X10MM WITH REINFORCING PLATE  
KIT TUBO RETTANGOLARE PER ILLUMINAZIONE 30X10MM CON PIASTRA DI RINFORZO 4900/12.  
CON ALMA DE ACERO INOX

Al	⊔ 1 m	30x10	€/u
	⊙ 4901		



LED no incluido. LED recomendado de 5mm de ancho. Incluye perfil de plástico superior y difusor interior.

TUBO RECTANGULAR PARA ILUMINACIÓN 30X10MM CON PLETINA DE REFUERZO  
KIT TUBE RECTANGULAIRE POUR ECLAIRAGE 30X10MM AVEC PLAQUE DE RENFORT  
KIT RECTANGULAR TUBE FOR LIGHTING 30X10MM WITH REINFORCING PLATE  
KIT TUBO RETTANGOLARE PER ILLUMINAZIONE 30X10MM CON PIASTRA DI RINFORZO 4900/12.  
CON ALMA DE ACERO INOX

Al	⊔ 1 m	30x10	€/u
	⊙ 4901		



182 diodos (20λ); cortable cada 3.8 cm  
Cable, fil. wire, cavo: 40cm  
Ancho 5mm  
flexible y con cinta adhesiva flexible and self-adhesive

LED CON MINI-CONECTOR 24V  
BANDE LED AVEC MINI-PLUG 24V  
LED STRIP WITH MINI-PLUG 24V  
STRACIA LED CON MINI-PLUG 24V 4910/109

Pla	⊔ 1 m	⚡ 5000 K	€/u
	⊙ CRI>90	⊙ 15,3W 24V	



182 diodos (20λ); cortable cada 3.8 cm  
Cable, fil. wire, cavo: 40cm  
Ancho 5mm  
flexible y con cinta adhesiva flexible and self-adhesive

LED CON MINI-CONECTOR 24V  
BANDE LED AVEC MINI-PLUG 24V  
LED STRIP WITH MINI-PLUG 24V  
STRACIA LED CON MINI-PLUG 24V 4910/109

Pla	⊔ 1 m	⚡ 5000 K	€/u
	⊙ CRI>90	⊙ 15,3W 24V	

PLÁSTICO PLASTIQUE PLASTICA 09



VENTOSA TRANSPARENTE VENTOUSE SUCITON VENTOSA 2556/009

Pla	⊙ 14 mm	⊙ 4880	€/u
-----	---------	--------	-----

# KADÍ ELEKTRIC - PRIMO 25X25

## BARRA ACCES. FR. 5901/1..

KIT compuesto por:  
- Cartelas Ref.5380  
-Tubo rectangular  
Ref.4900/128  
-LED de 1m



**BARRA DE CUELGUE PARA  
ACCESORIOS FRONTALES  
CON ILUMINACIÓN Y  
PROTECCIÓN PLÁSTICA  
SUPERIOR**  
**5901/1..**

**MONTADO**

Barre de suspension pour  
accessoires avant avec  
éclairage  
Hanger bar for front  
accessories with lighting  
Barra appendibili per  
accessori frontali per  
illuminazione

1M máx.  
7 cm

PL. M	BLANCO	NEGRO	COLOR
ALU. M	BLANC	NOIR	COULEUR
ALU. M	WHITE	BLACK	COLOR
ALL. NAT	BIANCO	NERO	COLORE
01	0B	0N	0P

€/u

○ ○ ○

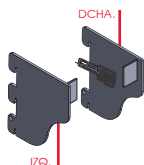

Kit de 2  
cartelas:  
DERECHA (con  
conector) +  
IZQUIERDA

**KIT CARTELAS BARRA  
ACCESORIOS**  
**KIT SUPPORT BARRE  
ACCESOIRES**  
**KIT BRACKET FOR  
ACCESSORIES ROD**  
**KIT MENSOLA TUBO  
PORTA-ACCESSORI**  
**5380/0..**

Fe 4900 71 mm medida útil €/u

○ ○ ○

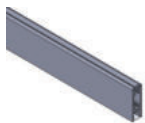

LED no incluido.  
LED  
recomendado de  
5mm de ancho.  
Incluye perfil de  
plastico superior y  
difusor interior.

**KIT TUBO RECTANGULAR  
PARA ILUMINACIÓN  
30X10MM**  
**KIT TUBE RECTANGULAIRE  
POUR ECLAIRAGE  
30X10MM**  
**KIT RECTANGULAR TUBE  
FOR LIGHTING 30X10MM**  
**KIT TUBO RETTANGOLARE  
PER ILLUMINAZIONE  
30X10MM**  
**4900/10.**

Al 6 m 30x10 €/m  
4901

○ ○ ○



182 diodos (20λ);  
cortable cada  
3,8 cm  
Cable, fil. wire,  
cavo: 45 mm  
Ancho 5mm  
flexible y con  
cinta adhesiva  
fleible and  
self-adhesive

**LED CON  
MINI-CONNECTOR 24V**  
**BANDE LED AVEC  
MINI-PLUG 24V**  
**LED STRIP WITH  
MINI-PLUG 24V**  
**STRACIA LED CON  
MINI-PLUG 24V**  
**4901/109**

Pla 1 m 5000 K €/u  
CRI > 90 15,3W 24V

PLÁSTICO  
PLASTIQUE  
PLASTICA

09

○

## EJEMPLO DE APLICACIÓN

Barras de  
accesorios con  
cuelgue frontal.

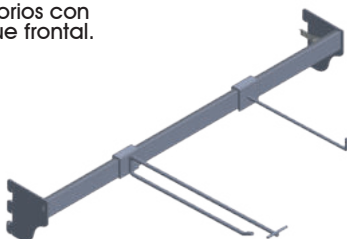

**KADÍ - PRIMO 25X25****KADÍ - PRIMO****TUBO TROQUELADO 25X25 MM**

KADÍ PRIMO es un sistema modular para crear todo tipo de muebles en tubo de hierro 25x25 mm.  
Sistema compatible con cartelas y accesorios Kadí.

Kadí Primo est un système modulaire pour créer toutes sortes de meubles en tubes 25x25 mm.  
Système compatible avec les supports et accessoires Kadí.

Kadí Primo is a modular system to create all kinds of furniture in iron 25x25 mm tube.  
System compatible with Kadí brackets and accessories.

KADÍ PRIMO è un sistema modulare per creare tutti i tipi di mobili in tubo di ferro 25x25 mm.  
Sistema compatibile con mensole e accessori Kadí.

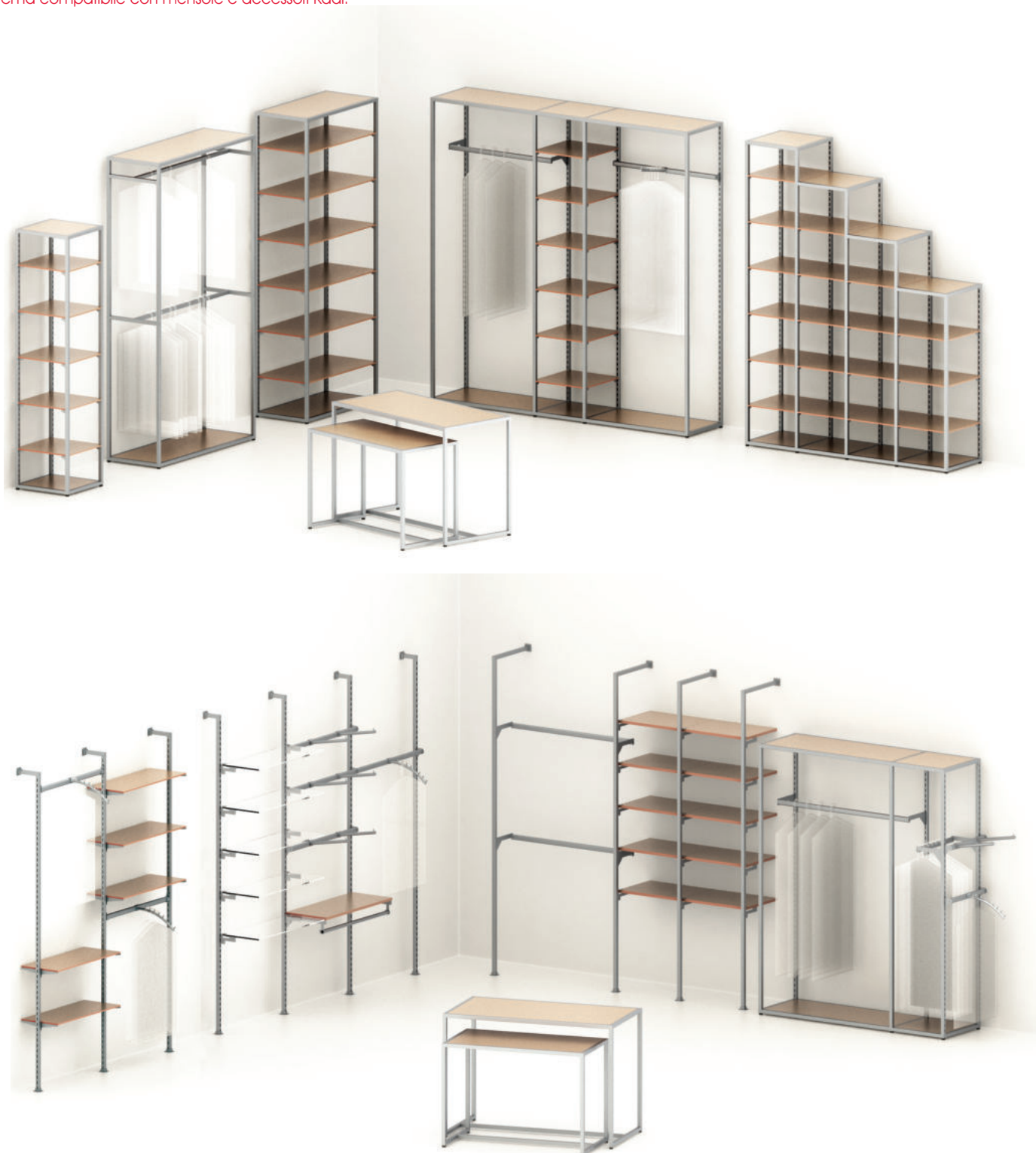

# KADI - PRIMO 25X25

# KADI - PRIMO 25X25

CR. BRILLO	BLANCO	NEGRO	COLOR
CR. POLI	BLANC	NOR	COULEUR
CR. CHR	WHITE	BLACK	COLOR
CR. ILLC.	BAVCO	NERO	COLORE
<b>32</b>	<b>OB</b>	<b>ON</b>	<b>OP</b>

Fe	25x25x1,2 mm	€/u
----	--------------	-----

		○	○

Fe	25x25x1,2 mm	€/u
----	--------------	-----

		○	○

Fe	25x25x1,2 mm	€/u
----	--------------	-----

		○	○
		○	○

Fe		€/u
----	--	-----

		○	○
		○	○

SISTEMA KADÍ-PRIMO: COMPATIBLE CON ACCESORIOS SISTEMA KADÍ

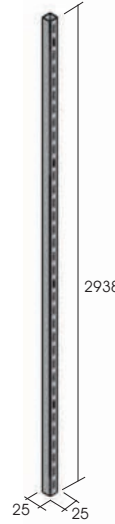

**TUBO 25X25 TROQUELADO 1 CARA**  
TUBE PERFORATION SIMPLE 1 CÔTE  
TUBE SINGLE SLOT CHANNEL 1 SIDE  
TUBO PERFORAZIONE SINGOLA 1 LATI  
**3943/3.. 2938 mm**

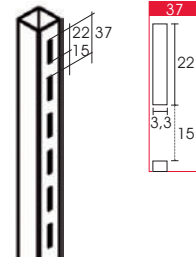

**TUBO 25X25 DOBLE TROQUELADO 1 CARA**  
TUBE PERFORATION DOUBLE 1 CÔTE  
TUBE DOUBLE SLOT CHANNEL 1 SIDE  
TUBO PERFORAZIONE DOPPIA 1 LATO  
**3945/3.. 2938 mm**

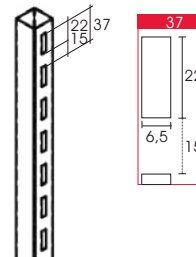

**TUBO 25X25 TROQUELADO 2 CARAS**  
TUBE PERFORATION SIMPLE 2 CÔTES  
TUBE SINGLE SLOT CHANNEL 2 SIDES  
TUBO PERFORAZIONE SINGOLA 2 LATI  
**3944/3.. 2938 mm**

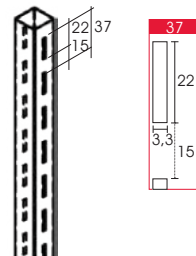

**APOYO ESTANTE**  
TAGUET ÉTAGÈRE  
SHELF SUPPORT  
SUPPORTO MENSOLO  
**3914/0..** derecha  
droite/right/destra  
**3913/0..** izquierda  
gauche/left/sinistra

# KADI - PRIMO NUDOS PRESIÓN

CR. BRILLO CH.R. POLI BR. CHR CR. ILLC.	BLANCO BLANC WHITE BIANCO	NEGRO NOR BLACK NERO	COLOR COULEUR COLOR COLORE
32	OB	ON	OP



NUDO 3 VIAS  
JOINT À 3 VOIES  
3 WAY JOINT  
GIUNTO 3 VIE  
3900/0..

Zn	25x25 mm	€/u
----	----------	-----

<input type="radio"/>	<input type="radio"/>	<input type="radio"/>
-----------------------	-----------------------	-----------------------



NUDO 3 VIAS + ROSCAMI0  
JOINT À 3 VOIES + TROU M10  
3 WAY JOINT + M10 HOLE  
GIUNTO 3 VIE + FORO M10  
3901/0..

Zn	25x25mm	€/u
----	---------	-----

<input type="radio"/>	<input type="radio"/>	<input type="radio"/>
-----------------------	-----------------------	-----------------------



NUDO 4 VIAS  
JOINT À 4 VOIES  
4 WAY JOINT  
GIUNTO 4 VIE  
3902/0..

Zn	25x25 mm	€/u
----	----------	-----

<input type="radio"/>	<input type="radio"/>	<input type="radio"/>
-----------------------	-----------------------	-----------------------



NUDO 4 VIAS + ROSCAMI0  
JOINT À 4 VOIES + TROU M10  
4 WAY JOINT + M10 HOLE  
GIUNTO 4 VIE + FORO M10  
3903/0..

Zn	25x25mm M10	€/u
----	-------------	-----

<input type="radio"/>	<input type="radio"/>	<input type="radio"/>
-----------------------	-----------------------	-----------------------



NUDO 5 VIAS  
JOINT À 5 VOIES  
5 WAY JOINT  
GIUNTO 5 VIE  
3904/0..

Zn	25x25mm	€/u
----	---------	-----

<input type="radio"/>	<input type="radio"/>	<input type="radio"/>
-----------------------	-----------------------	-----------------------



NUDO 3 VIAS "T"  
JOINT À 3 VOIES "T"  
"T" 3 WAY JOINT  
GIUNTO 3 VIE "T"  
3907/0..

Zn	20x20mm	€/u
----	---------	-----

<input type="radio"/>	<input type="radio"/>	<input type="radio"/>
-----------------------	-----------------------	-----------------------



NUDO 2 VIAS  
JOINT À 2 VOIES  
2 WAY JOINT  
GIUNTO 2 VIE  
3905/0..

Zn	25x25mm	€/u
----	---------	-----

<input type="radio"/>	<input type="radio"/>	<input type="radio"/>
-----------------------	-----------------------	-----------------------

## ACCESORIOS PARA TUBO 25X25

CR. NEGRO



PL. NEGRO

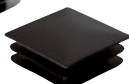

TAPÓN TUBO 25X25  
EMBOUT  
END-CAP  
COPRITESTA  
3911/032

Fe	25x25 mm	€/u
----	----------	-----

PL. NEGRO

<input type="radio"/>	<input type="radio"/>
-----------------------	-----------------------

PL. NEGRO



TAPÓN M10 TUBO 20X20  
END-CAP with M10 hole  
EMBOUT avec m10 trou  
COPRITESTA con foro M10  
3912/000

Zn	25x25 mm M10	€/u
----	--------------	-----

PL. NEGRO

<input type="radio"/>
-----------------------



ANCLAJE TUBO 25X25  
FIXATION TUBE  
TUBO FIXING  
FISSAGGIO TUBO  
3929/032

Zn	25x25 mm	€/u
----	----------	-----

<input type="radio"/>	<input type="radio"/>	<input type="radio"/>
-----------------------	-----------------------	-----------------------

# KADI - PRIMO NUDOS BRIDA

CR. BRILLO CH.R. POLI BR. CHR CR. ILLC.	BLANCO BLANC WHITE BIANCO	NEGRO NOR BLACK NERO	COLOR COULEUR COLOR COLORE
32	OB	ON	OP



NUDO 3 VIAS  
JOINT À 3 VOIES  
3 WAY JOINT  
GIUNTO 3 VIE  
3980/0..

Zn	25x25 mm	€/u
----	----------	-----

<input type="radio"/>	<input type="radio"/>	<input type="radio"/>
-----------------------	-----------------------	-----------------------



NUDO 4 VIAS  
JOINT À 4 VOIES  
4 WAY JOINT  
GIUNTO 4 VIE  
3982/0..

Zn	25x25 mm	€/u
----	----------	-----

<input type="radio"/>	<input type="radio"/>	<input type="radio"/>
-----------------------	-----------------------	-----------------------



NUDO 4 VIAS  
JOINT À 4 VOIES  
4 WAY JOINT  
GIUNTO 4 VIE  
3988/0..

Zn	25x25 mm	€/u
----	----------	-----

<input type="radio"/>	<input type="radio"/>	<input type="radio"/>
-----------------------	-----------------------	-----------------------



NUDO 5 VIAS  
JOINT À 5 VOIES  
5 WAY JOINT  
GIUNTO 5 VIE  
3984/0..

Zn	25x25mm	€/u
----	---------	-----

<input type="radio"/>	<input type="radio"/>	<input type="radio"/>
-----------------------	-----------------------	-----------------------



NUDO 6 VIAS  
JOINT À 6 VOIES  
6 WAY JOINT  
GIUNTO 6 VIE  
3986/0..

Zn	25x25mm	€/u
----	---------	-----

<input type="radio"/>	<input type="radio"/>	<input type="radio"/>
-----------------------	-----------------------	-----------------------



NUDO 3 VIAS "T"  
JOINT À 3 VOIES "T"  
"T" 3 WAY JOINT  
GIUNTO 3 VIE "T"  
3987/0..

Zn	20x20mm	€/u
----	---------	-----

<input type="radio"/>	<input type="radio"/>	<input type="radio"/>
-----------------------	-----------------------	-----------------------



NUDO 2 VIAS  
JOINT À 2 VOIES  
2 WAY JOINT  
GIUNTO 2 VIE  
3985/0..

Zn	25x25mm	€/u
----	---------	-----

<input type="radio"/>	<input type="radio"/>	<input type="radio"/>
-----------------------	-----------------------	-----------------------



TUBO 25X25 mm  
TUBE 25X25 mm  
TUBE 25x25 mm  
TUBO 25x25 mm  
3989/0..

Fe	25x25x1,2	€/u
----	-----------	-----

<input type="radio"/>	<input type="radio"/>	<input type="radio"/>
-----------------------	-----------------------	-----------------------

**! NUEVO**

## TUBO 25X25



TUBO 25X25 mm  
TUBE 25X25 mm  
TUBE 25x25 mm  
TUBO 25x25 mm  
3910/3..

Fe	L 3 m	25x25x1,2	€/u
----	-------	-----------	-----

<input type="radio"/>	<input type="radio"/>	<input type="radio"/>
-----------------------	-----------------------	-----------------------



# KADI - PRIMO 25X25

CR. BRILLO CHR. POLI BR. CHR CR. ILLUC.	CR. MATE CHR. M M. CHR CR. OPAC	BLANCO BLANC WHITE BIANCO	NEGRO NOIR BLACK NERO	COLOR COULEUR COLOR COLORE
32	31	0B	0N	0P

## CARTELA FINAL BARRA ACCESORIOS (36X18)

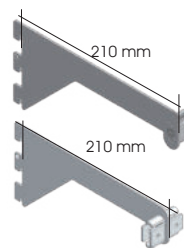

**CARTELA BARRA PENDERIE**  
SUPPORT BARRE PENDERIE  
BRACKET HANGING BAR  
MENSOLA APPENDERIA

210 mm

210 mm

**3946/0..** derecha  
droite/right/destra

**3947/0..** izquierda  
gauche/left/sinistra

**3948/0..** intermedia  
inter./inter./inter.

Fe	210 mm	∞ 4547	€/u



**CARTELA BARRA ACCESORIOS**  
SUPPORT BARRE ACCESSOIRES  
BRACKET FOR ACCESSORIES ROD  
MENSOLA TUBO PORTA-ACCESSORI

**4716/0..** derecha  
droite/right/destra

**4717/0..** izquierda  
gauche/left/sinistra

Fe	60mm	∞ 4547 (36x18)	€/u



**CARTELA BARRA ACCESORIOS**  
SUPPORT BARRE ACCESSOIRES  
BRACKET FOR ACCESSORIES ROD  
MENSOLA TUBO PORTA-ACCESSORI

**4715/0..** intermedia  
inter./inter./inter.

--	--	--	--



**TUBO OVAL 36x18 mm**  
TUBE OVALE 36x18 mm  
OVAL TUBE 36x18 mm  
TUBO OVALE 36x18 mm

**4547/1..**

Fe	3 m	36x18x1,5	€/m



**PERROQUET PLANO**  
PENDERIE FRONTAL  
STRAIGHT ARM  
APPENDERIA FRONTALE

**3019/0..**

Fe	∞ 4547	300 mm	€/u



**PERROQUET INCLINADO**  
PENDERIE INCLINÉE  
SLOPING ARM  
APPENDERIA INCLINADA

**3022/0..**

Fe	∞ 4547	300 mm	€/u



**GANCHO CROCHET**  
HOOK  
BARRETTA

**3014/0..** 25 cm

**3020/0..** 20 cm

**3021/0..** 10 cm

Fe	∞ 4547	€/u



**GANCHO PORTAPRECIO**  
CROCHET PORTAPRIX  
HOOK LABEL-HOLDER  
BARRETTA PORTAPREZZO

**3012/0..** 25 cm

Fe	∞ 4547-382	€/u



**PORTAPRECIO**  
PORTAPRIX  
LABELHOLDER  
PORTAPREZZO

**382/009**

plac	40x50 mm	€/u



**CARTELA CENTRAL**  
SUPPORT CROCHET CENTRAL  
BRACKET WITH CENTRAL HOOK  
MENSOLA INCASTRO CENTRALE

30

**4631/0..** 30 cm

Fe	∞ 3944	€/u



**SOPORTE TUBO OVAL 4547**  
SUPPORT TUBE PENDERIE 4547  
HANGING TUBE 4547 SUPPORT  
SUPPORTO TUBO APPENDERIA 4547

**4546/0..**

Fe	∞ 4547 (36x18mm)	∞ 3944	€/u

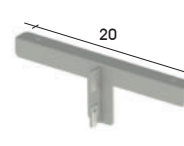

**CARTELA CENTRAL**  
SUPPORT CROCHET CENTRAL  
BRACKET WITH CENTRAL HOOK  
MENSOLA INCASTRO CENTRALE

20

**4630/0..** 30 cm

Fe	∞ 4505-4510+4606	€/u

# KADI PRIMO 25X25

CR. BRILLO CHR. POLI BR. CHR CR. ILLUC.	INOX SAT INOX SAT S.S.S.	CR. MATE CHR. M M. CHR CR. OPAC	BLANCO BLANC WHITE BIANCO	NEGRO NOIR BLACK NERO	COLOR COULEUR COLOR COLORE
32	28	31	0B	0N	0P

## CARTELAS "PLANAS" - TUBO 30X10

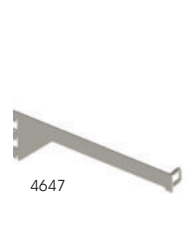

**CARTELA BARRA PENDERIE**  
SUPPORT BARRE PENDERIE  
BRACKET HANGING BAR  
MENSOLA APPENDERIA

30x10 mm (4585)

**4648/0..** derecha  
droite/right/destra

**4647/0..** izquierda  
gauche/left/sinistra

Fe	∞ 4585(30x10)	320 mm	€/u



**CARTELA BARRA ACCESORIOS**  
SUPPORT BARRE ACCESSOIRES  
BRACKET FOR ACCESSORIES ROD  
MENSOLA TUBO PORTA-ACCESSORI

**4580/0..** derecha  
droite/right/destra

**4581/0..** izquierda  
gauche/left/sinistra

Fe	∞ 4585(30x10)	€/u



**SOPORTE TUBO RECTANGULAR 4585**  
SUPPORT TUBE RECTANGULAIRE 4585  
SUPPORT TUBE RECTANGULAR 4585  
SUPPORTO TUBO RETTANGOLARE 4585

**4634/0..**

Fe	∞ 4585	€/u



**TUBO RECTANGULAR**  
TUBE RECTANGULAIRE  
RECTANGULAR TUBE  
TUBO RETTANGOLARE

**4585/1..**

Fe	3 m	30x10x1,4	€/m



**TAPA FINAL CON TOPE**  
EMBOUT AVEC RÉTENTION  
END-CAP WITH STOP  
COPRITESTA + RETENZIONE

**4586/0..**

Fe	∞ 4585	40x10 mm	€/u



**PERROQUET PLANO**  
PENDERIE FRONTAL  
STRAIGHT ARM  
APPENDERIA FRONTALE

**4592/0..**

Fe	∞ 4585	350 mm	€/u



**PERROQUET INCLINADO**  
PENDERIE INCLINÉE  
SLOPING ARM  
APPENDERIA INCLINADA

**4593/0..**

Fe	∞ 4585	400 mm	€/u



**GANCHO CROCHET**  
HOOK  
BARRETTA

**4594/0..** 20 cm

Fe	∞ 4585	€/u



**GANCHO PORTAPRECIO**  
CROCHET PORTAPRIX  
HOOK LABEL-HOLDER  
BARRETTA PORTAPREZZO

**4597/0..** 25 cm

Fe	∞ 4585-382	€/u



**PORTAPRECIO**  
PORTAPRIX  
LABELHOLDER  
PORTAPREZZO

**382/009**

plac	40x50 mm	€/u



# KADI - PRIMO

## EJEMPLOS DE MONTAJE

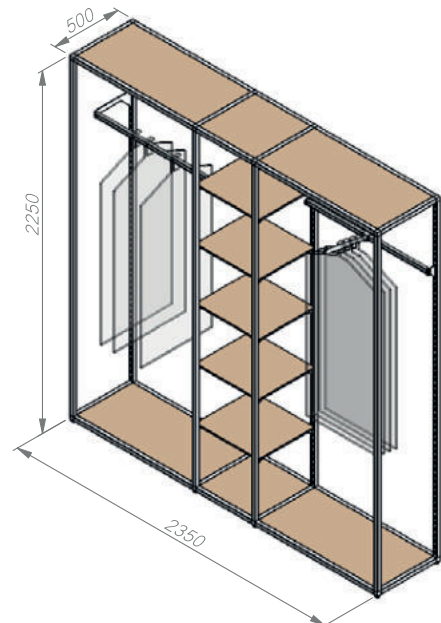
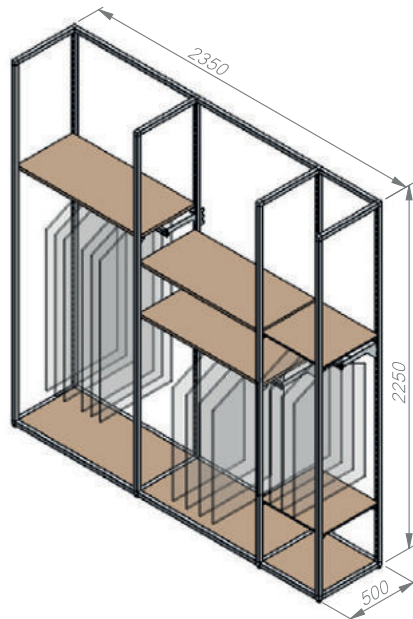
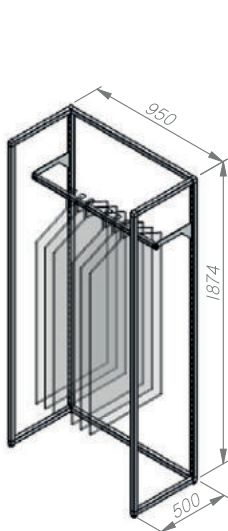
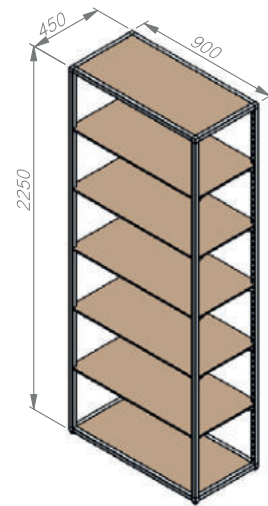
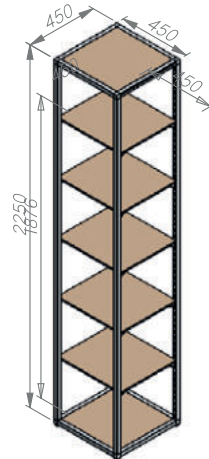
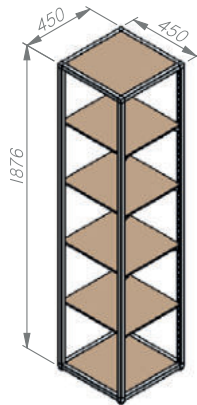
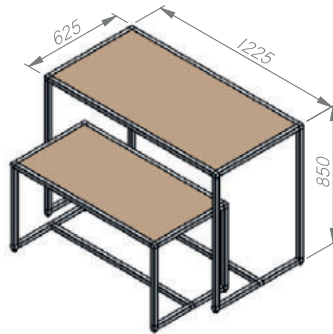
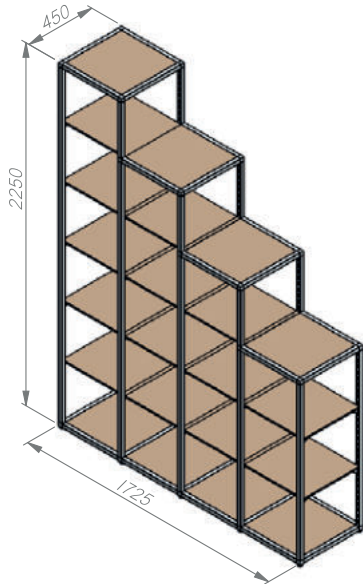

# KADI - PRIMO NUDOS BRIDA

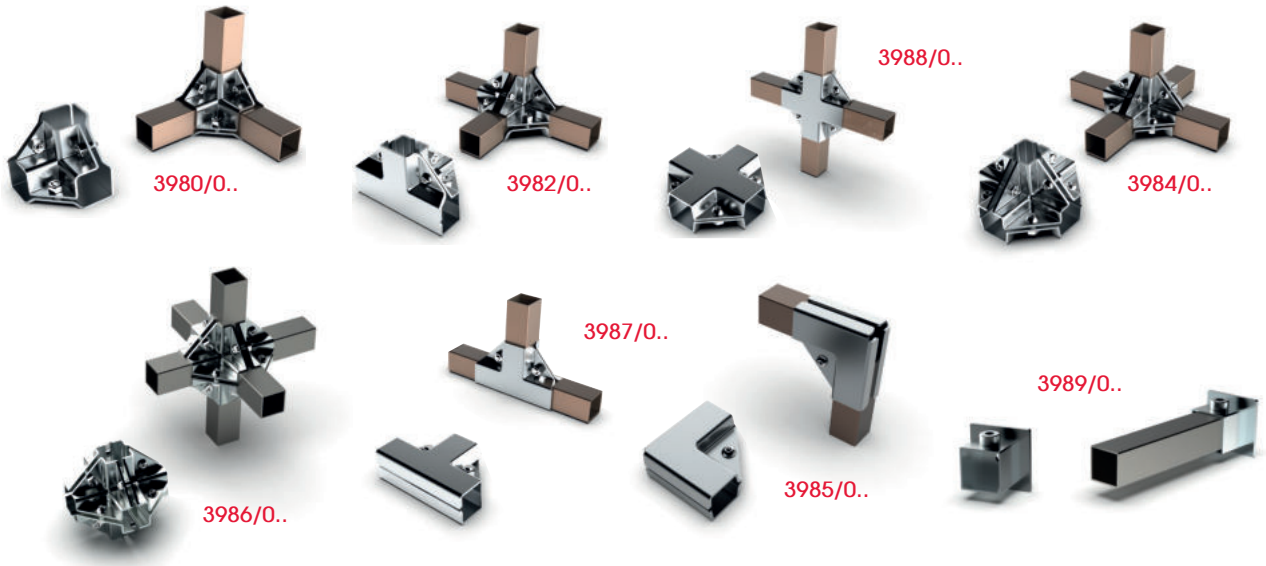



## INSTAL - ÍNDEX

### EASY LIGHT

#### Sistemas de iluminación de muebles

<b>1- MAGNETIC LED</b>	<b>89</b>
Carril electrificado con lámparas LED imantadas	
<b>2- EASY</b>	<b>91</b>
Sistema universal de carriles electrificados y conectores para electrificar cualquier mueble	
<b>3- VARIO</b>	<b>93</b>
Sistema de iluminación empotrado para muebles	

## EASY LIGHT - MAGNETIC LED



## NUEVO / ILUMINACIÓN

## MAGNETIC LED

## SISTEMA DE ILUMINACIÓN

- Sistema de riel de suministro eléctrico para módulos de iluminación combinables con imán, perfecto para estantes, gabinetes, escaparates, etc.
- Múltiples métodos y ángulos de instalación (adhesivado, atornillado, encastrado, etc).
- Tamaño pequeño, acabado integrado y apto para espacios estrechos.
- Fácil instalación.
- Sistema de vía de alimentación eléctrica fácilmente conectable. Con diferentes módulos de iluminación combinables.

## CARRIL

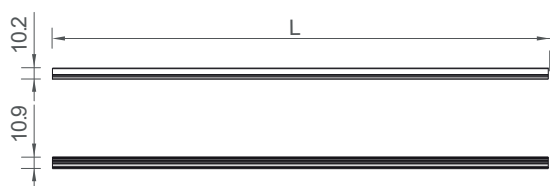

## SPOT LIGHT

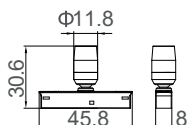

## STRIP LIGHT

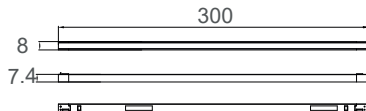

- 2** Instalación a 45° - invisible  
(Método de instalación:  
Clips o cinta adhesiva)

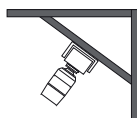

- 2** Instalación a 90° - invisible  
(Método de instalación:  
Clips)

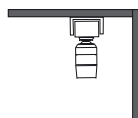

Los dos métodos anteriores se ajustan a la vitrina y al escaparate

- 3** Instalación montada en superficie  
(Método de instalación:  
Clips o cinta adhesiva)

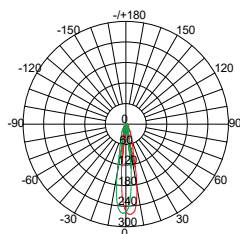
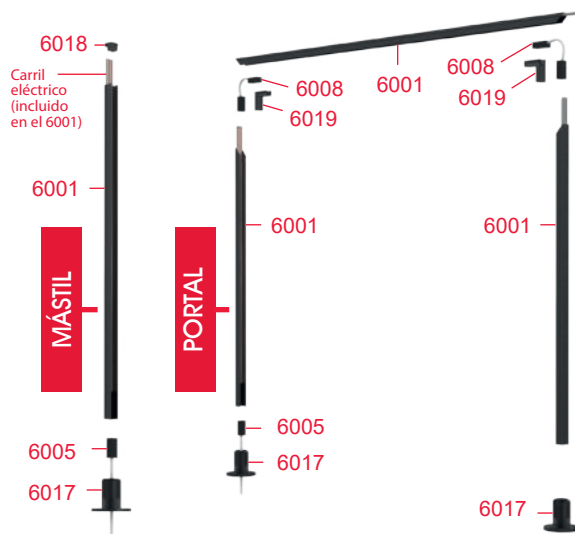
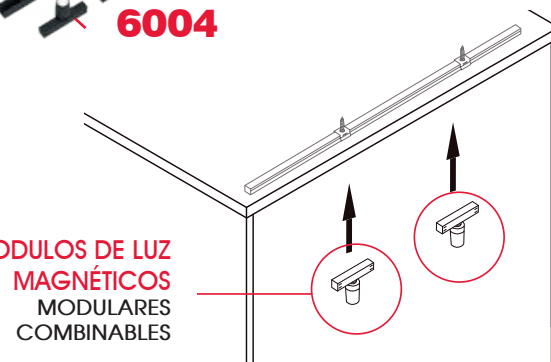

## INTENSIDAD LUMINOSA

MODULOS DE LUZ  
MAGNÉTICOS  
MODULARES  
COMBINABLES

## ESPECIFICACIONES

	CARRIL	LUZ FOCAL	LUZ LINEAR
TAMAÑO:	Lx10.2x10.9mm (Longitud opcional)	30.6x11.8mm	300x8x8.5mm
ENTRADA NOMINAL:	/	24V DC	24V DC
FUERZA:	/	0.6W	3.5W
FLUJO LUMINOSO (TYP@4000K):	/	38lm	266lm
RA:	/	90	90
EFICIENCIA:	/	67lm/W	75lm/W
IP:	20	20	20
COLOR:	Negro	Negro	Negro
CCT:	/	4000K	4000K
INSTALACIÓN:	Clips / Cinta adh.	Magnética	Magnética

# EASY LIGHT - MAGNETIC LED

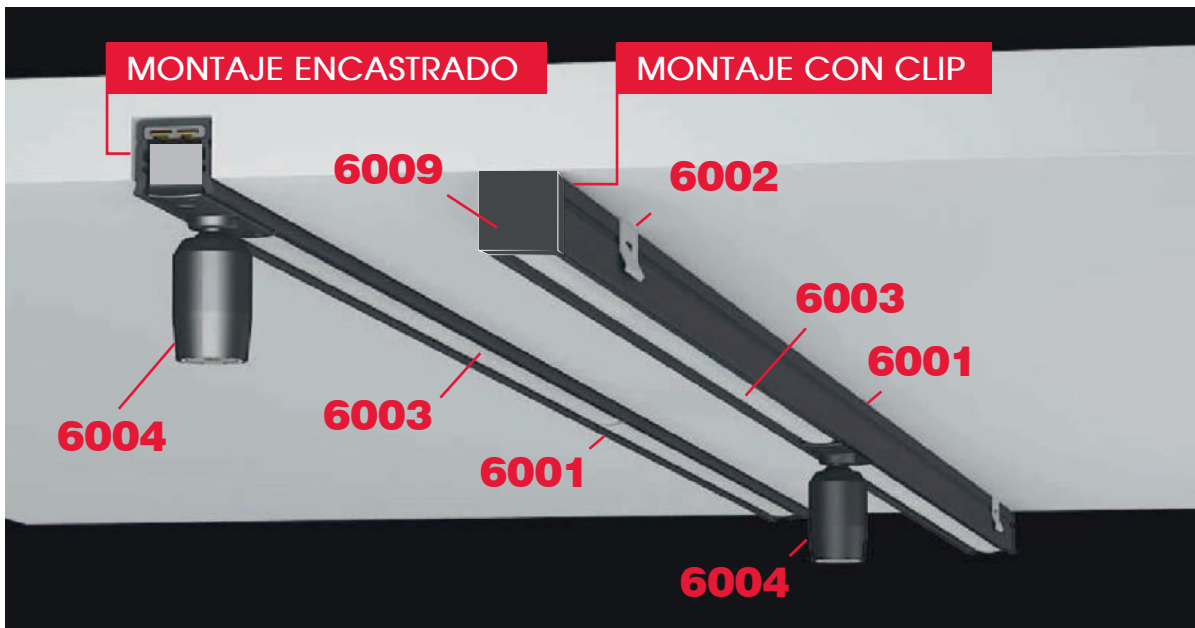

## MAGNETIC LED

INOX SAT NEGRO  
INOX SAT INOR  
S.S.S. BLACK  
INOX SAT NERO

28 ON

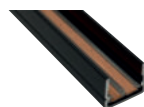

MAGNÉTICO

CARRIL ELECTRIFICADO  
MAGNÉTICO  
RAIL ÉLECTRIFIÉ MAGNÉTIQUE  
MAGNETIC ELECTRIFIED RAIL  
BINARIO ELETRIFICATO  
MAGNETICO  
6001/20N

2 m €/u

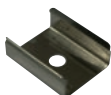

CLIP PARA FIJACIÓN  
CLIP DE FIXATION  
FIXING CLIP  
CLIP DI FISSAGGIO  
6002/028

6001-6012 €/u

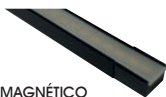

MAGNÉTICO

LED ILUMINACIÓN LINEAR  
ÉCLAIRAGE LINÉAIRE À DEL  
LED LINEAR LIGHTING  
ILLUMINAZIONE LINEARE A LED  
6003/00N

4000 K 3,5 W 24V €/u  
30 cm



MAGNÉTICO

MÓDULO DE ILUMINACIÓN FOCAL  
MODULE PLEINS FEUX  
SPOTLIGHT MODULE  
MODULO FARETTO  
6004/00N

4000 K 0,8 W 24V €/u  
30 cm

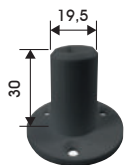

Posibilidad de encastrar (taladro: Ø20mm)

BASE (FORMATO VERTICAL)  
BASE (FORMAT VERTICAL)  
BASE (VERTICAL FORMAT)  
BASE (FORMATO VERTICALE)  
6017/00N

Plata 19,5mm €/u



TAPA DE CARRIL (6001)  
COUVERCLE DE RAIL (6001)  
RAIL COVER (6001)  
COPRIBINARIO (6001)  
6018/00N

Plata €/u



UNIÓN 90°  
UNION 90°  
90° UNION  
UNIONE 90°  
6019/00N

Plata €/u

## MAGNETIC LED

NEGRO  
INOR  
BLACK  
NERO

ON



MAGNÉTICO

CONECTOR MAGNÉTICO  
CARRIL-DRIVER  
CONNECTEUR MAGNÉTIQUE RAIL-DRIVER  
MAGNETIC CONNECTOR RAIL-DRIVER  
CONNETTORE MAGNETICO RAIL-DRIVER  
6005/00N

Plata 2A €/u  
150cm



MAGNÉTICO

CONECTOR MAGNÉTICO  
CARRIL-CONECTOR CARTELAS KADÍ  
CONNECTEUR MAGNÉTIQUE  
RAIL-CONNECTEUR SUPPORT KADI  
MAGNETIC CONNECTOR  
RAIL-CONNECTOR KADI BRACKET  
CONNETTORE MAGNETICO BINARIO  
- CONNETTORE MENSOLA KADI  
6006/00N

Plata 2A €/u  
40cm



MAGNÉTICO

CONECTOR MAGNÉTICO  
CARRIL-LED UNIVERSAL  
CONNECTEUR MAGNÉTIQUE  
RAIL-LED UNIVERSAL  
MAGNETIC CONNECTOR  
RAIL-UNIVERSAL LED  
CONNETTORE MAGNETICO  
BINARIO-UNIVERSALE LED  
6007/00N

Plata 2A €/u  
40cm



MAGNÉTICO

CONECTOR MAGNÉTICO  
CARRIL-CARRIL  
CONNECTEUR MAGNÉTIQUE  
RAIL-RAIL  
MAGNETIC CONNECTOR  
RAIL-RAIL  
CONNETTORE MAGNETICO BINARIO  
- BINARIO  
6008/00N

Plata 2A €/u  
4 cm



6 SALIDAS

DRIVER 100W, 24V /  
CONECTOR HEMBRA  
CONDUCTEUR 100W, 24V /  
CONNECTEUR FEMELLE  
DRIVER 100W, 24V /  
FEMALE CONNECTOR  
DRIVER 100W, 24V /  
CONNETTORE FEMMINA  
6010/009

Plata 24V 100W €/u  
15cm

PLÁSTICO  
PLASTIQUE  
PLASTIC  
PLASTICA

09

## EASY LIGHT - EASY



## NUEVO / ILUMINACIÓN

## EASY

## CARRIL

- Sistema de riel de suministro eléctrico para módulos de iluminación combinables con imán, perfecto para estantes, gabinetes, escaparates, etc.
- Múltiples métodos y ángulos de instalación (adhesivado, atornillado, encastrado, etc).
- Tamaño pequeño, acabado integrado y apto para espacios estrechos.
- Fácil instalación.
- Sistema de vía de alimentación eléctrica fácilmente conectable. Con diferentes módulos de iluminación combinables.

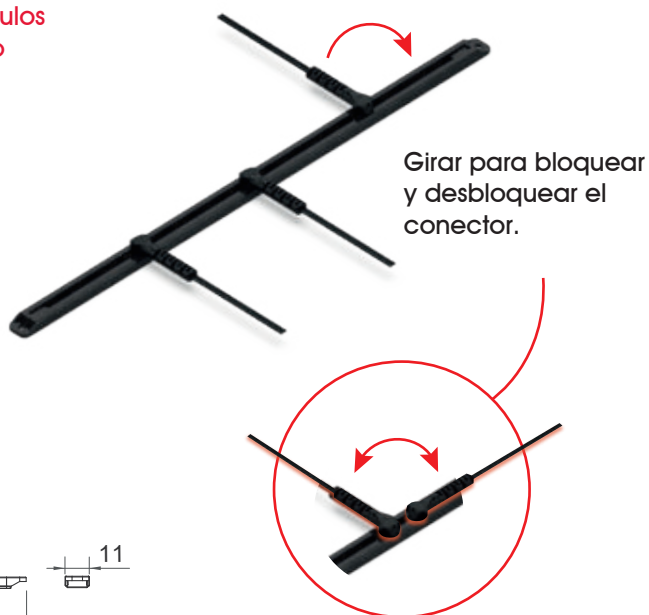

## CARRIL

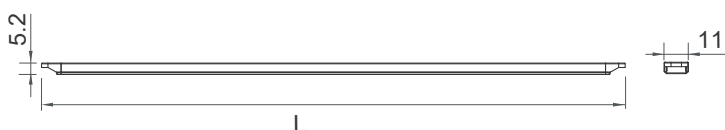

## CABLE

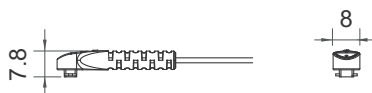

LONGITUD:	Lx11x5.2mm
CABLE DE ENTRADA:	22# AWG UL 2468 CABLE
INPUT:	8A
CABLE DE SALIDA:	22# AWG UL 2468 CABLE
OUTPUT:	3A
MAX. LONGITUD:	2500mm
INSTALACIÓN:	Montaje Magnético, Montaje con Tornillos, Adhesivado
COLOR:	Blanco / Negro

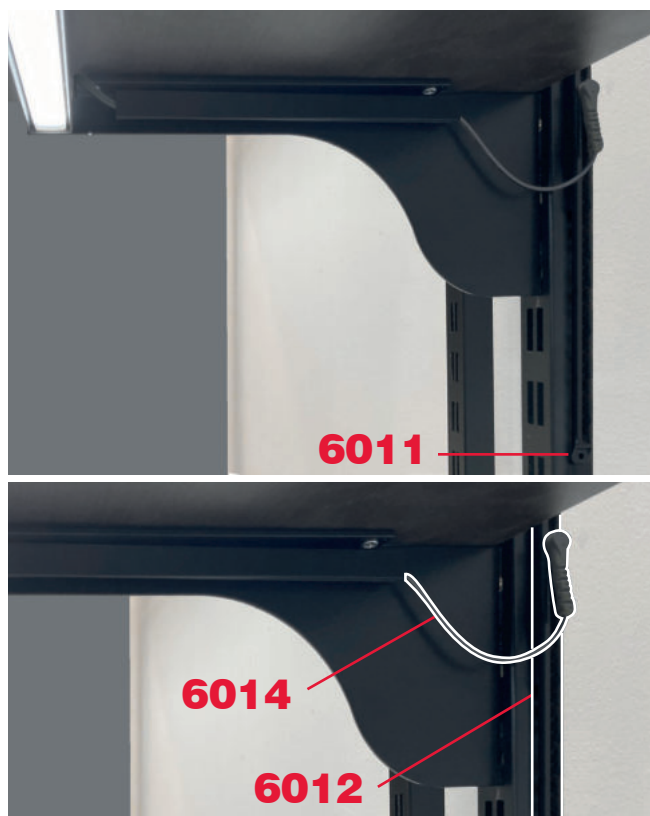



# EASY LIGHT - EASY



## EASY



**CARRIL ELECTRIFICADO**  
RAIL ÉLECTRIFIÉ  
ELECTRIFIED RAIL  
BINARIO ELETRIFICATO  
**6012/25.**



(X2 u.)

**TAPÓN FINAL**  
BOUCHON D'EXTRÉMITÉ  
END PLUG  
TAPPO FINE  
**6011/0..**



MAGNÉTICO

**CINTA MAGNÉTICA ADHESIVA**  
RUBAN MAGNÉTIQUE ADHÉSIF  
ADHESIVE MAGNETIC TAPE  
NASTRO MAGNETICO ADESIVO  
**6012/000 50M**  
**6012/100 1M**



**CINTA ADHESIVA DOBLE CARA**  
RUBAN MAGNÉTIQUE ADHÉSIF  
ADHESIVE MAGNETIC TAPE  
NASTRO MAGNETICO ADESIVO  
**6012/009**



126 diodos (20λ); cortable cada 5.5 cm  
Cable: fil, wire, cavo: 40cm  
Ancho 8 mm  
flexible y con cinta adhesiva flexible and self-adhesive

**LED CON MINI-CONECTOR 24V**  
BANDE LED AVEC MINI-PLUG 24V  
LED STRIP WITH MINI-PLUG 24V  
STRIACIA LED CON MINI-PLUG 24V  
**4890/009**

BLANCO BLANC WHITE BIANCO	NEGRO NOIR BLACK NERO
OB	ON

2,5 m 24V €/u

o o

€/u

o o

PLÁSTICO  
PLASTIQUE  
PLASTIC  
PLASTICA

09

€/u

o

€/m

o

€/u

consultar

1 m 5000 K €/u

CRI > 90 9,6 W 24V

o

## EASY

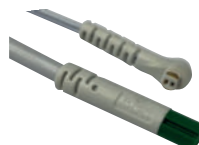

**CONECTOR CARRIL-DRIVER /**  
CONECTOR SEGURIDAD ALUSYSTEM  
CONNECTEUR RAIL-DRIVER /  
CONNECTEUR SÉCURITÉ DU ALUSYSTEM  
CONNECTOR RAIL-DRIVER /  
CONNECTOR ALUSYSTEM SECURITY  
CONNETTORE RAIL-DRIVER /  
CONNETTORE LA SICUREZZA ALUSYSTEM  
**6013/0..**



**CONECTOR CARRIL-LED / HEMBRA**  
CONNECTEUR RAIL-LED / FEMELLE  
RAIL-LED CONNECTOR / FEMALE  
CONNETTORE RAIL-LED / FEMMINA  
**6014/0..**



**CABLE CONEXIÓN DRIVER**  
PARA SOLDAR  
MODULE PLEINS FEUX  
SPOTLIGHT MODULE  
MODULO FARETTO  
**6015/00B**



6 SALIDAS

**DRIVER 100W, 24V /**  
CONECTOR HEMBRA  
CONDUCTEUR 100W, 24V /  
CONNECTEUR FEMELLE  
DRIVER 100W, 24V /  
FEMALE CONNECTOR  
DRIVER 100W, 24V /  
CONNETTORE FEMMINA  
**6010/009**

BLANCO BLANC WHITE BIANCO	NEGRO NOIR BLACK NERO
OB	ON

Placa 24V €/u

1M

o o

Placa 24V €/u

10cm

o o

Placa 1M €/u

o

Placa 24V 100W €/u

PLÁSTICO  
PLASTIQUE  
PLASTIC  
PLASTICA

09

o

# SISTEMA - VARIO

## SISTEMA ILUMINACIÓN PARA MUEBLES DE MADERA

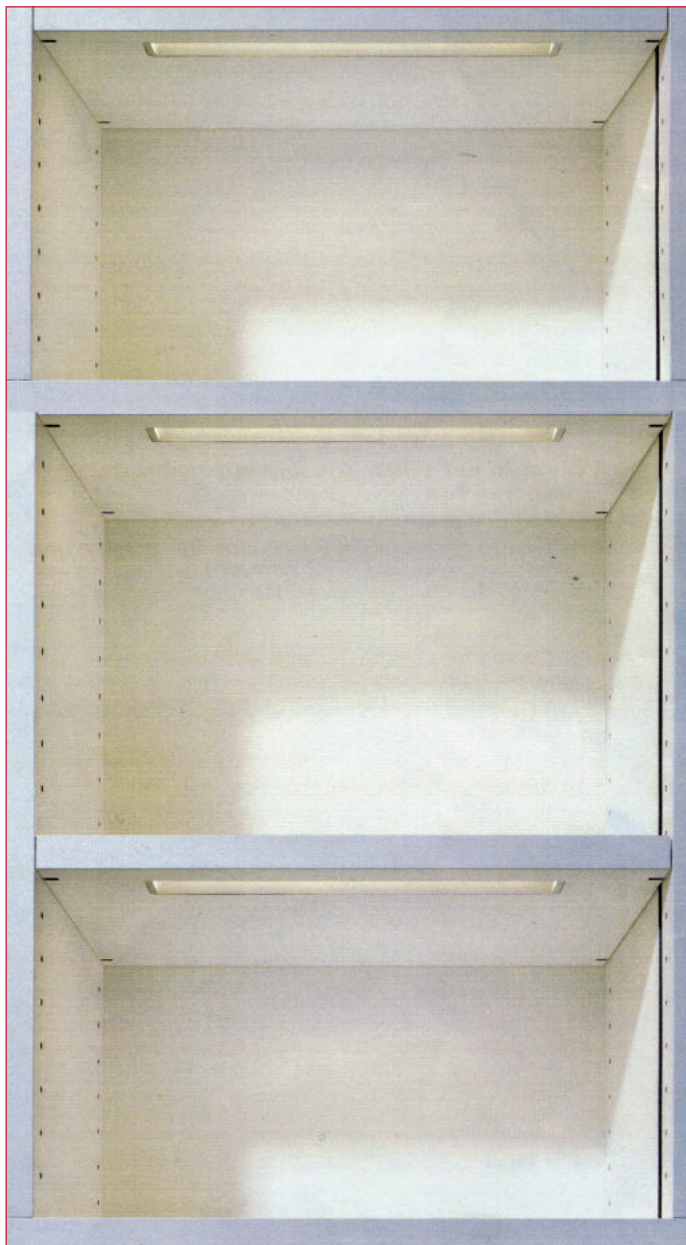
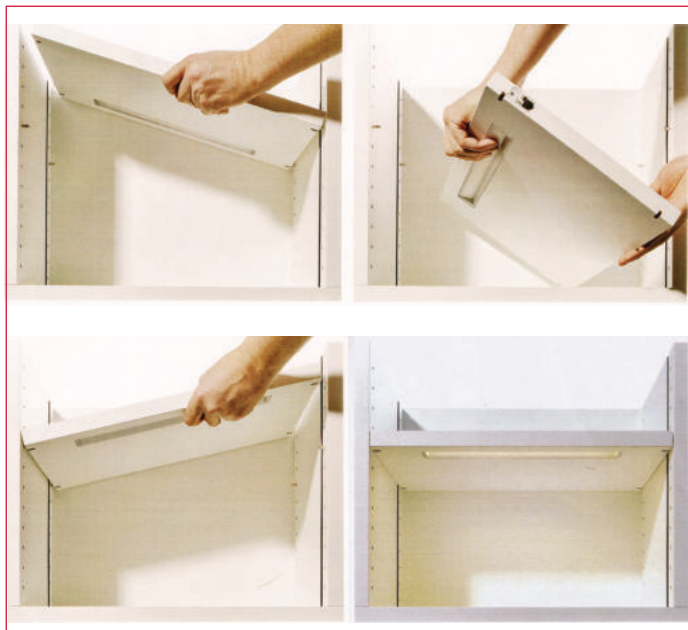

VARIO es una nueva solución de iluminación para la electrificación de estanterías de madera.

- Los estantes pueden colocarse de manera fácil a cualquier altura sin preocuparse de la conexión eléctrica.

- Grosor mínimo estante: 22 mm

- 24 V

VARIO est une nouvelle solution d'éclairage pour l'électrification des étagères en bois.

- Les étagères peuvent être situées facilement à n'importe quelle hauteur indépendamment de la connexion électrique.

- Épaisseur min. étage: 22 mm

- 24V

VARIO is a new lighting solution for wood shelves electrification.

- Shelves can be placed easily at any height without worrying about the electrical connections.

- Minimum shelf thickness: 22 mm

- 24V

VARIO è una nuova soluzione di illuminazione per l'elettificazione di scaffalature in legno.

- Le mensole possono essere posizionate facilmente a qualsiasi altezza senza preoccuparsi delle connessioni elettriche.

- Spessore min. ripiano: 22 mm

- 24 V

# SISTEMA-VARIO

PLÁSTICO  
PLASTIQUE  
PLASTIC  
PLASTICA  
09

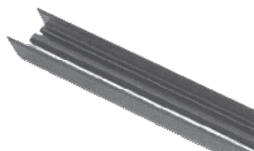

plas	3000 mm	24V - máx 6A	€/u
------	---------	--------------	-----

CARRIL ELECTRIFICADO  
RAIL D'ALIMENTATION 24V  
POWER RAIL 24V  
BINARIO ELETRIFICATO 24V  
**\*4805/309**

\*o

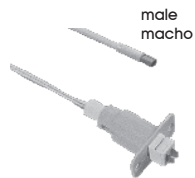

male  
macho

plas	400 mm	24V - máx 6A	€/u
------	--------	--------------	-----

CONECTOR ALIMENTACIÓN CARRIL - DRIVER  
ALIMENTACION DE CONECTOR RAIL - DRIVER  
FEEDER CONNECTOR TRACK - DRIVER  
CONNETTORE BINARIO ELETRIFICATO - DRIVER  
**\*4807/049**

\*o

UNO POR CARRIL

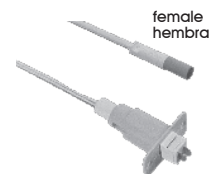

female  
hembra

plas	100 mm	24V - máx 6A	€/u
------	--------	--------------	-----

CONECTOR LED A CARRIL ELECTRIFICADO  
LED CONECTOR A RAIL D'ALIMENTATION  
LED CONNECTOR TO POWER RAIL  
CONNETTORE LED A BINARIO ELETRIFICATO  
**\*4806/109**

\*o

UNO POR ESTANTE



macho  
male



Al	CRI >85	9W - 24V	€/u
----	---------	----------	-----

4000 K

PERFIL ALUMINIO + LED  
ALUMINIUM PROFIL + LED  
ALUMINIUM PROFILE + LED  
ALLUMINIO PROFILO + LED  
**\*4809/089** 862 mm

\*o

plas	3 m	100W - 230V > 24V	€/u
------	-----	-------------------	-----

DRIVER + 6 SALIDAS CON  
MINI-CONECTORES 24V  
DRIVER + DISTRIBUTEUR 6 SORTIES  
AVEC MINI-PLUG 24V  
DRIVER + DISTRIBUTOR 6 WAYS-BLOCK  
WITH MINI-PLUG 24V  
DRIVER + DISTRIBUTORE 6 USCITE  
CON MINI-PLUG 24V  
**\*4770/009**

\*o

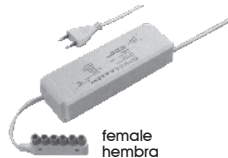

female  
hembra

plas	1,5 m	50W - 230V > 24V	€/u
------	-------	------------------	-----

DRIVER + 6 SALIDAS CON  
MINI-CONECTORES 24V  
DRIVER + DISTRIBUTEUR 6 SORTIES  
AVEC MINI-PLUG 24V  
DRIVER + DISTRIBUTOR 6 WAYS-BLOCK  
WITH MINI-PLUG 24V  
DRIVER + DISTRIBUTORE 6 USCITE  
CON MINI-PLUG 24V  
**\*4769/009**

\*o



female  
hembra  
male  
macho

plas	3 m	230V - 2,5 A	€/u
------	-----	--------------	-----

ENCHUFE + CABLE + MINI-CONECTOR 230V  
FICHE + CÂBLE + MINI-PLUG 230V  
EURO-PLUG + CABLE + MINI-PLUG 230V  
SPINA CORRENTE + CAVO + MINI-PLUG 230V  
**\*4773/009**

\*o



female  
hembra

plas	3 m	230V - 2,5 A	€/u
------	-----	--------------	-----

ENCHUFE + CAVO + DISTRIBUIDOR 6 SALIDAS  
CON MINI-CONECTORES 230V  
FICHE + CÂBLE + DISTRIBUTEUR 6 SORTIES  
AVEC MINI-PLUG 230V  
EURO-PLUG + CABLE + DISTRIBUTOR 6 WAYS-BLOCK  
WITH MINI-PLUG 230V  
SPINA-CORRENTE + DISTRIBUTORE 6 USCITE  
CON MINI-PLUG 230V  
**\*4771/009**

\*o



female  
hembra

# SISTEMA-VARIO

COMPRANDO EL SISTEMA COMPLETO DESDE EL ENCHUFE HASTA EL LED 4809:  
- 2 AÑOS DE GARANTIA  
- DESCUENTO ADICIONAL DEL 30%

El sistema completo no precisa certificado de instalación de baja tensión

## MONTAJE SISTEMA VARIO

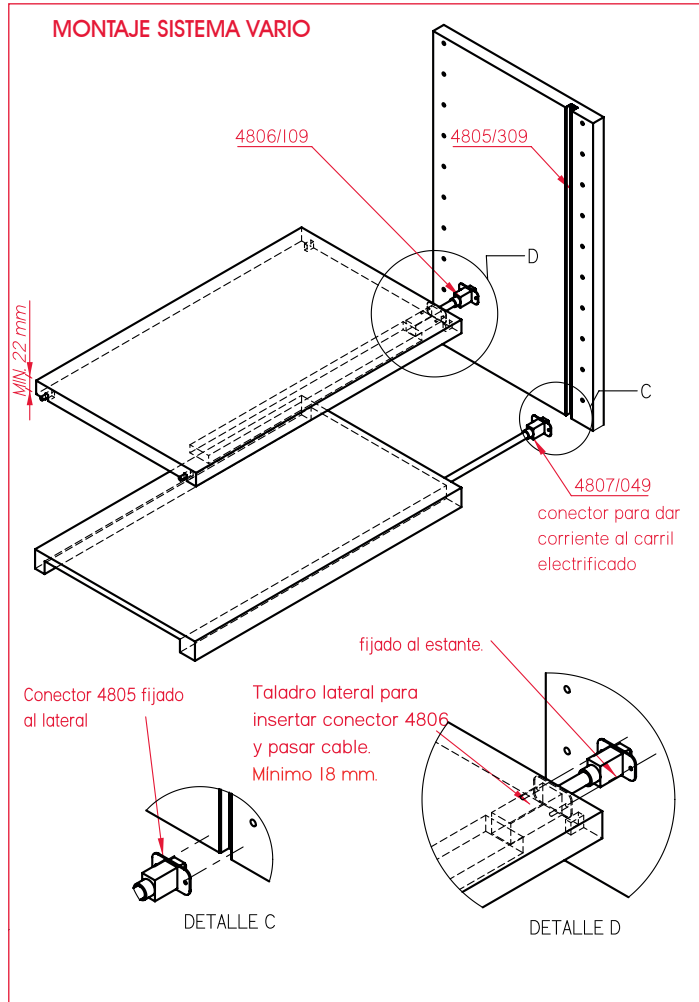

## DIMENSIONES REF. 4806 Y 4807

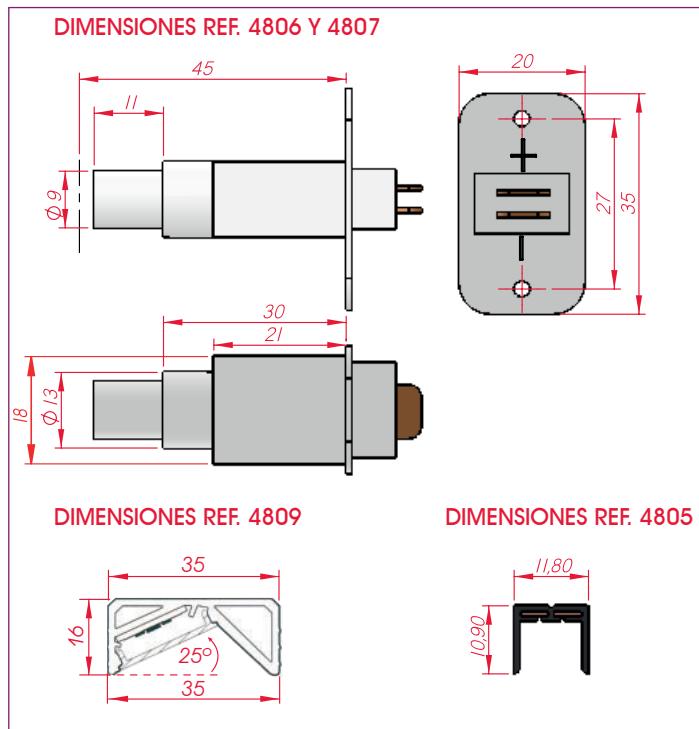



## INSTAL - ÍNDEX

### LAMAS

Sistema de organización horizontal de estanterías basado, con perfiles horizontales y accesorios comunes

1- PERFILES Y ACCESORIOS OCULTOS	97
2- LAMAS "DM"	103
3- LAMAS "ALUMINIO"	104
4- ACCESORIOS PARA LAMAS	105
5- PARALELO Ranura para accesorios 5/8 mm	107
6- OPTI 3 Ranura para accesorios 3 mm	109

## SISTEMA

## LAMAS



## Accesorios para perfil invisible 361

Accessoires pour le profil INVISIBLE 361

Fittings for the INVISIBLE profile 361

Accessori per il Profilo INVISIBLE 361

# SISTEMA LAMAS

## PANELES Y PERFILES

PANNEAUX ET PROFILS  
PANELS AND PROFILES  
PANNELLI E PROFILI

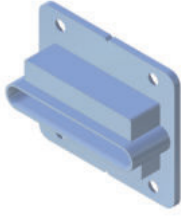

Casquillo LAMAS  
ref. 359

Insert LAMAS  
LAMAS socket  
Boccola LAMAS



Lamas INVISIBLE  
ref. 361

Profil INVISIBLE  
INVISIBLE profile  
Profilo INVISIBLE

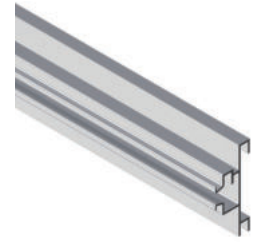

Lamas INVISIBLE+cremallera  
ref. 403 + ref. 400

Profil INVISIBLE + crémaillère  
INVISIBLE profile + rack  
Profilo INVISIBLE + cremagliera

### COMPATIBLES CON:

COMPATIBLE AVEC :  
COMPATIBLE WITH:  
COMPATIBLE CON:

#### STOCK ALU SYSTEM

1. accesorios hierro  
accessoires en fer, iron fittings, accessori di ferro
2. accesorios aluminio  
accessoires aluminium, aluminium fittings,  
accessori alluminio
3. accesorios plástico  
accessoires plastique, plastic fittings, accessori  
plastica

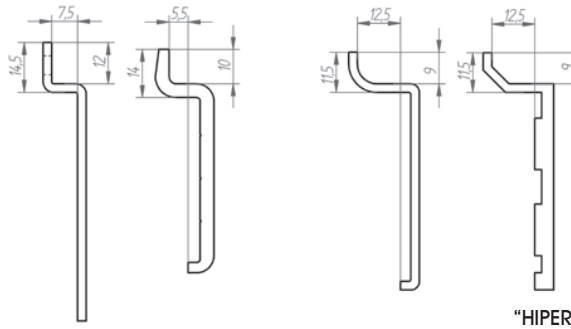

### COMPATIBLES CON:

COMPATIBLE AVEC :  
COMPATIBLE WITH:  
COMPATIBLE CON:

accesorios "HIPER" (no stock)  
accessoires "HIPER", "HIPER" fittings, accessori "HIPER"



Lamas "DM" ref. 477-432

Panneau rainuré MDF avec profils  
slatwall panel MDF with profiles  
Pannello dogato MDF con profili

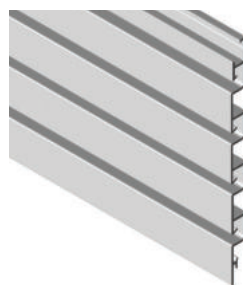

Lama aluminio ref. 429

Profil LAME D'ALUMINIUM  
ALUMINIUM SLATWALL profile  
Profilo DOGATO DI ALLUMINIO

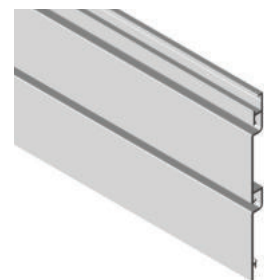

Lama aluminio ref. 427

Profil LAME D'ALUMINIUM  
ALUMINIUM SLATWALL profile  
Profilo DOGATO DI ALLUMINIO



Perfil para "DM" ref. 450

Profil d'aluminium x panneau rainuré  
aluminium profile x slatwall panel  
Profilo di alluminio x pannello dogato

### COMPATIBLES CON:

COMPATIBLE AVEC :  
COMPATIBLE WITH:  
COMPATIBLE CON:

#### STOCK ALU SYSTEM

1. accesorios hierro  
accessoires en fer, iron fittings, accessori di ferro
- ⊕ 2. accesorios aluminio  
accessoires aluminium, aluminium fittings,  
accessori alluminio
3. accesorios plástico  
accessoires plastique, plastic fittings, accessori  
plastica

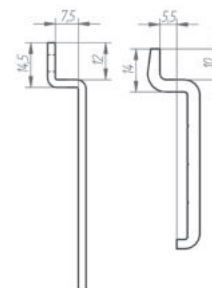

# SISTEMA LAMAS 361

## LAMA ALUMINIO INVISIBLE 361

- Admite estante de vidrio de 6 y 8 mm
- SE RECOMIENDA VIDRIO DE SEGURIDAD
- Sistema machihembrado
- Peso max. admitido según tipo de montaje:  
Estante vidrio 8 mm: 50 kg/ml  
Estante vidrio 6 mm: 25 kg/ml
- Accesorios: 20 kg/u. ó peso max. admitido por cada accesorio (si inferior a 20 kg)
- Admite iluminación LED en el canal del perfil
- Compatibles con accesorios estándar de Lamas (admite accesorios tipo "Hiper") y accesorios especiales 361

## LAMA aluminium INVISIBLE 361

- Permet étagère en verre de 6 et 8 mm d'épaisseur
- Verre de sécurité est recommandé
- montage panneau à emboîtement
- Max. poids admis en fonction du type de montage:  
Étagère en verre de 8mm: 50 kg / ml  
Étagère en verre de 6mm: 6 mm 25 kg / ml
- Accessoires: 20 kg / u. ou poids max. approprié pour chaque accessoire (si moins de 20 kg)
- Permet l'éclairage LED
- Compatible avec les accessoires standards (Lamas et raccords spéciaux tels que "Hiper") et accessoires spéciaux 361

## LAMA aluminium INVISIBLE 361

- Allows glass shelf 6 and 8 mm thick
- Safety glass is recommended
- Socket joint or panel fitting from behind.
- Max. admitted weight depending on assembly type:  
8 mm glass shelf: 50 kg / ml  
6 mm glass shelf: 25 kg / ml
- Accessories: 20 kg / u. weight or max. suitable for each accessory (if less than 20 kg)
- Allows LED lighting
- Compatible with standard accessories Lamas (and special fittings such as "Hiper") and special fittings 361 series

## LAMA alluminio INVISIBLE 361

- ammette ripiani in vetro di 6 e 8 mm
- Si raccomanda l'uso di vetro sicurizzato
- Sistema incastro
- Peso massimo ammesso a seconda del tipo di montaggio:  
Ripiano di vetro 8 mm: 50 kg/ml  
Ripiano di vetro 6 mm: 25 kg/ml
- Accessori: 20 kg/u. o peso massimo ammesso per cadauno (se inferiore a 20 kg).
- Ammette LEDs
- Compatibile con accessori standard Lamas (e accessori speciali tipo "Hiper") e accessori speciali 361



### Montaje a pared

Montage mural  
Wall mounting  
Montaggio a parete

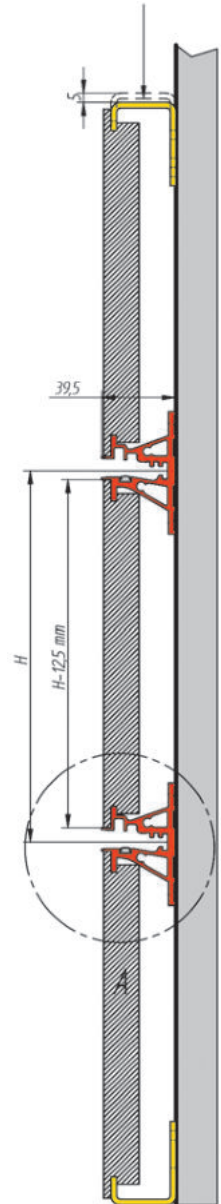
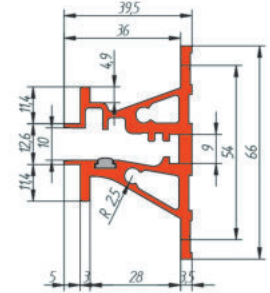
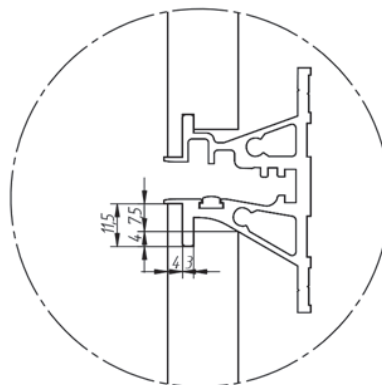
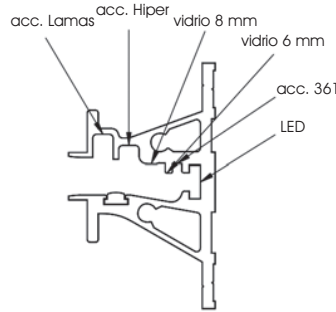



# LAMAS - 361

BLANCO BLANC WHITE BIANCO	NEGRO NOIR BLACK NERO	COLOR COULEUR COLOR COLORE	PL. M ALU. M ALL. NAT
OB	ON	OP	01

## LAMAS "INVISIBLE"

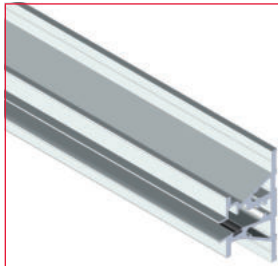

LAMA ALUMINIO  
PROFIL D'ALUMINIUM  
ALUMINIUM PROFILE  
PROFILO DI ALLUMINIO

COMPATIBLE CON:  
ACC. ESTÁNDAR LAMAS  
ACC. ESPECIALES HIPER.  
ACC. 361  
361/1..

Al	5 m	6/8 mm	€/m
----	-----	--------	-----

○	○	○	○
---	---	---	---



SOPORTE PANEL INFERIOR/SUPERIOR  
SUPPORT BOIS INFÉRIEUR / SUPÉRIEUR  
WOOD SUPPORT LOWER / UPPER  
SUPPORTO PANNELLO LEGNO  
INFERIORE / SUPERIORE  
370/00B

Fe	45x35x40	€/u
----	----------	-----

○		
---	--	--

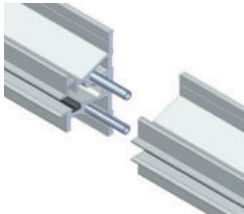

PASADOR UNIÓN PERFILES Ø5 mm  
BROUCHE À RESSORT Ø 5 mm  
BOLT JOINING PROFILES Ø 5 mm  
PERNO A MOLLA Ø 5 mm  
358/000

Fe	600x380 mm	∅ 361	€/u
----	------------	-------	-----

		○
--	--	---

### Estantes de vidrio

se recomienda vidrio templado

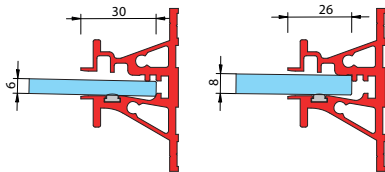

### Accesorios LAMAS    Accesorios HIPER    Accesorios 361

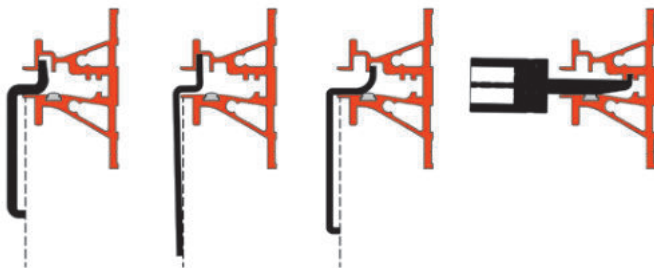

# LAMAS - 361

ACCESORIOS 361 - ACCESSOIRES 361  
FITTINGS 361 - ACCESSORI 361

CR. BRILLO CHR. POLI BR. CHR CR. LUC.	INOX BR INOX POLI PSS INOX LUC	CR. MATE CHR. M M. CHR CR. OPAC	BLANCO BLANC WHITE BIANCO	NEGRO NOIR BLACK NERO	COLOR COULEUR COLOR COLORE
32	22	31	OB	ON	OP

## ACCESORIOS LAMAS "INVISIBLE"

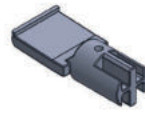

SUPPORTO ACCESORIOS  
SUPPORT ACCESSOIRES  
ACCESSOIRES SUPPORT  
SUPPORTO ACCESSORI  
300/022

inox s.s.	para tubo Ø25x1,5 mm	€/u
-----------	----------------------	-----

○		
---	--	--



CARTELA  
SUPPORT  
BRACKET  
MENSOLA  
305/0..

Fe	∅ 361	350 mm	€/u
----	-------	--------	-----

		○
--	--	---



GANCHO  
CROCHET  
HOOK  
GANCIO  
\*306/0..

Fe	∅ 361	200 mm	€/u
----	-------	--------	-----

		*○
--	--	----



PERROQUET PLANO  
PENDERIE FRONTAL  
STRAIGHT ARM  
APPENDERIA FRONTALE  
301/031 250 mm  
309/031 350 mm

Fe	∅ 361		€/u
----	-------	--	-----

		○
--	--	---



PERROQUET PLANO "S"  
PENDERIE FRONTAL "S"  
STRAIGHT ARM "S"  
APPENDERIA FRONTALE "S"  
307/0..

Fe	∅ 361	350 mm	€/u
----	-------	--------	-----

		○
--	--	---



PERROQUET INCLINADO  
PERRQUET INCLINÉE  
SLOPING ARM  
APPENDERIA INCLINADA  
302/0..

Fe	∅ 361	400 mm	€/u
----	-------	--------	-----

		○
--	--	---



CARTELA + BARRA PENDERIE  
SUPPORT + BARRE PENDERIE  
BRACKET + HANGING BAR  
MENSOLA + APPENDERIA  
303/0..

Fe	∅ 361 - 4547	350 mm	€/u
----	--------------	--------	-----

		○
--	--	---



CARTELA BARRA PENDERIE  
SUPPORT BARRE PENDERIE  
BRACKET HANGING BAR  
MENSOLA APPENDERIA  
304/0..

Fe	∅ 361 - 4547	320 mm	€/u
----	--------------	--------	-----

		○
--	--	---



TUBO OVAL 36x18 mm  
TUBE OVALE 36X18 mm  
OVAL TUBE 36X18 mm  
TUBO OVALE 36X18 mm  
4547/10P

Fe	1 m	36x18x1,5	€/m
----	-----	-----------	-----

		○
--	--	---



TAPA FINAL CON TOPE  
EMBOUT AVEC RÉTENTION  
END-CAP WITH STOP  
COPRITESTA + RETENZIONE  
\*4722/0..

Zn	46x18	∅ 4547 (36x18)	€/u
----	-------	----------------	-----

		*○
--	--	----

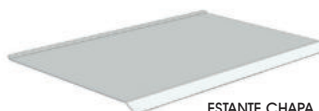

ESTANTE CHAPA  
TABLETTE EN MÉTAL  
METAL SHELF  
RIPIANO METALLICO  
371/00M

Fe	600x380 mm	∅ 361	€/u
----	------------	-------	-----

RAL 9006

		○
--	--	---

# LAMAS - CASQUILLO

BLANCO	NEGRO	COLOR	CR. MATE
BLANC	NOIR	COULEUR	CHR. M
WHITE	BLACK	COLOR	M. CHR
BIANCO	NERO	COLORE	CR. OPAC
OB	ON	OP	31

## CASQUILLO LAMAS

Zn	69x11	19 mm	€/u
----	-------	-------	-----

**CASQUILLO EMPOTRABLE**  
Para paneles de 19 mm  
Compatibles con los  
accesorios estandar  
de Alu System y accesorios  
especiales HIPER

**INSERT "LAMAS"**  
Bois 19 mm  
Compatible avec:  
Acc standard Lamas  
Acc. spécial Hiper

**"LAMAS" SOCKET TO INSERT**  
Wood 19 mm  
Compatible with:  
Acc Lamas Standard  
Acc. Hiper Special

**BOCCOLA "LAMAS" A INSERTO**  
Pannelli 19 mm  
Compatibile con:  
Acc. standard Lamas  
Acc speciali Hiper  
**359/031**

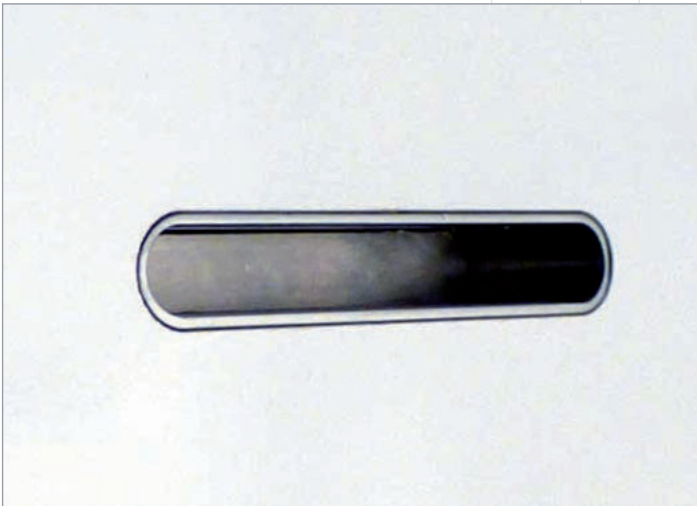
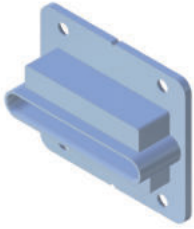

# LAMAS - CASQUILLO

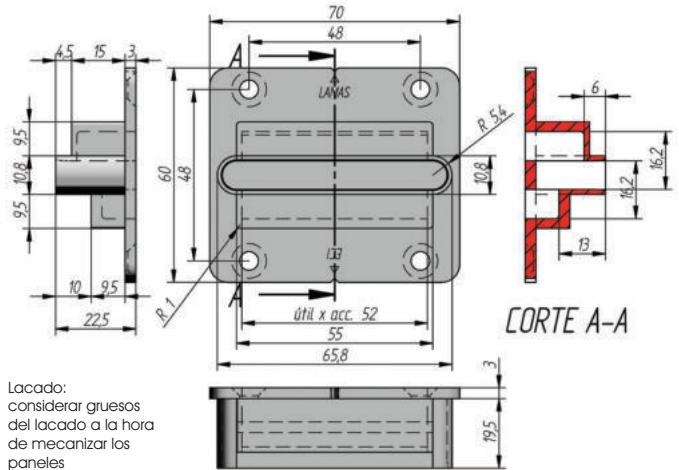

Lacado:  
considerar gruesos  
del lacado a la hora  
de mecanizar los  
paneles

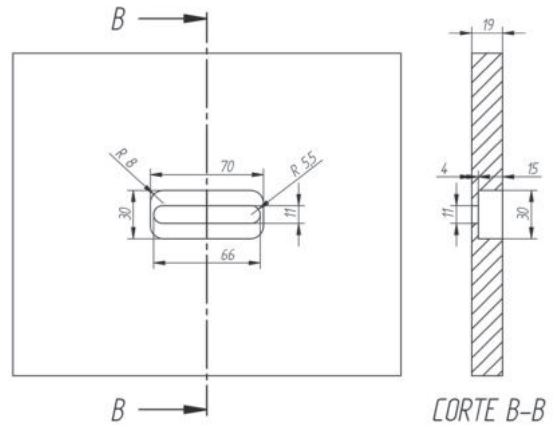

Accesorios de hierro LAMAS  
Steel fittings LAMAS  
Accessoires LAMAS acier  
Accessori di acciaio LAMAS



### MONTAJE CASQUILLO CON ACCESORIOS ESTÁNDAR "ALU SYSTEM"

MONTAGE ACCESSOIRE STAND-  
ARD "ALU SYSTEM"  
ASSEMBLY FOR STANDARD AC-  
CESSORY "ALU SYSTEM"  
MONTAGGIO PER ACCESSORI  
STANDARD "ALU SYSTEM"



### MONTAJE CASQUILLO CON ACCESORIOS ESPECIALES "HIPER"

MONTAGE ACCESSOIRE SPECIAL  
"HIPER"  
ASSEMBLY FOR SPECIAL AC-  
CESSORY "HIPER"  
MONTAGGIO PER ACCESSORI  
SPECIALI "HIPER"

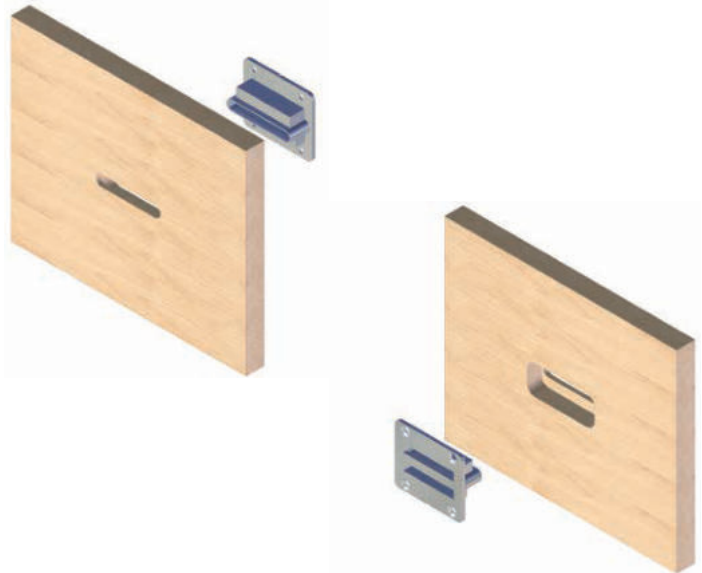

# LAMAS - ALUMINIO

BLANCO	NEGRO	COLOR	PL. M
BLANC	NOR	COULEUR	ALU. M
WHITE	BLACK	COLOR	ALU. M
BIANCO	NERO	COLORE	ALL. NAT
OB	ON	OP	01

## LAMAS "INVISIBLE" 403 INSTALACIÓN CON CREMALLERA

SISTEMA MACHIEMBRADO compatible con accesorios estándar de "Lamas" y especiales "Hiper"

SOCKET JOINT SYSTEM compatible with standard accessories "Lamas" and special accessories "Hiper"

SYSTÈME EMBOÏTEMENT compatible avec les accessoires standard "Lamas" et accessoires spéciaux "Hiper"

SISTEMA A INCASTRO compatible con accessori standard "Lamas" e con accessori speciali "Hiper"

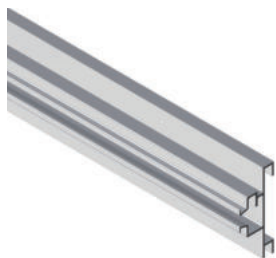

LAMA ALUMINIO CON CREMALLERA REF. 400  
MADERA: 10-16 mm compatible con: acc. estándar Lamas Acc. especiales "HIPER"

PROFIL D'ALUMINIUM "LAMAS" POUR CRÉMAILLÈRE REF. 400 Bois 10-16 mm Compatible avec: Acc standard Lamas Acc. spécial Hiper

ALUMINIUM PROFILE "LAMAS" WITH RACK REF. 400 Wood 10-16 mm Compatible with: Acc Lamas Standard Acc. Hiper Special

PROFLO DI ALLUMINIO "LAMAS" CON CREMAGLIERA REF. 400 Legno 10-16 mm Compattibile con: Acc. standard Lamas Acc speciali Hiper

403/1..

CREMALLERA PARED PARA PERFILES 401.. 403

CRÉMAILLÈRE MUR Avec profils 403 et 401 WALL RACK for profils 403 y 401 CREMAGLIERA PARETE con profili 403 e 401 400/334

Al		5 m	178x12,5	€/m
----	--	-----	----------	-----

Al		3 m	∅ 401-403	€/m
----	--	-----	-----------	-----

ZINCADO  
PL. ZINK  
ZINK PL.  
ZINCATO

34

○

# LAMAS - ALUMINIO

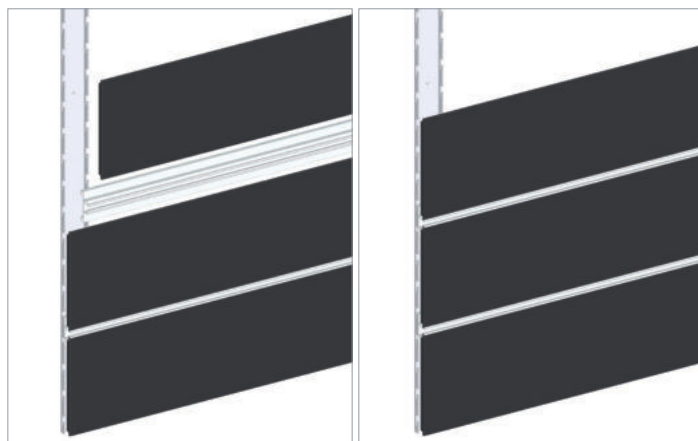
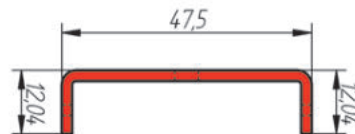
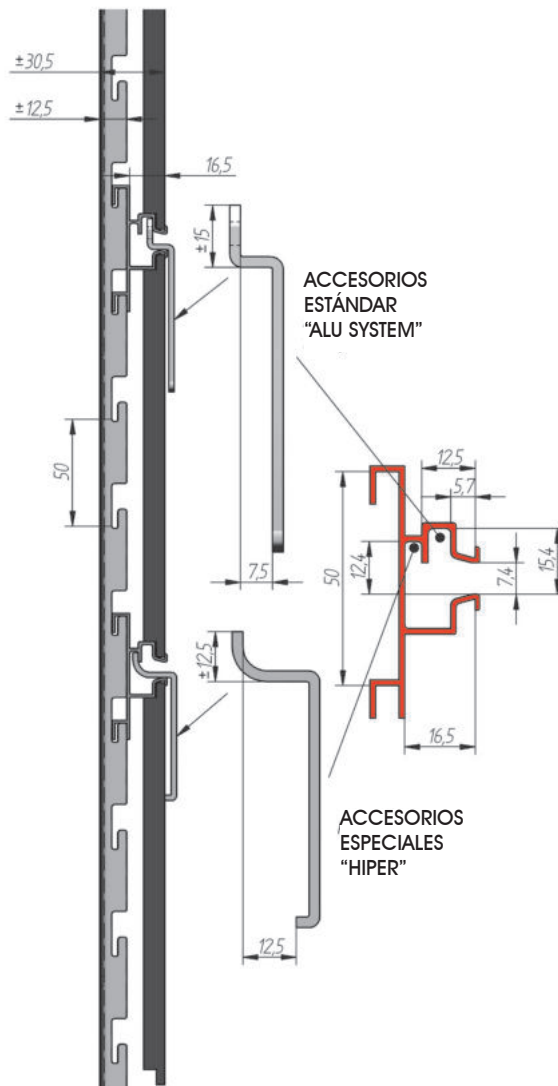

# LAMAS - DM

BLANCO	NEGRO	COLOR	PL. M
BLANC	NOIR	COULEUR	ALU. M
WHITE	BLACK	COLOR	ALU. M
BIANCO	NERO	COLORE	ALL. NAT
OB	ON	OP	O1

## LAMAS "DM"

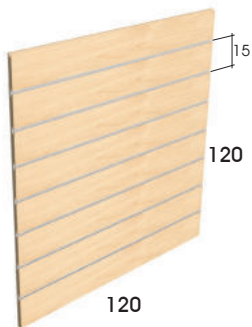

**LAMA PANEL DM**  
regata cada 15 cm.  
con perfil de aluminio "L" incluido

**PANNEAU RAINURÉ MDF**  
Fraisé 15 cm  
Profils en aluminium "L" inclus

**SLATWALL PANEL MDF**  
Milled: 15 cm  
Aluminium "L" profiles included

**PANNELLO DOGATO MDF**  
Fresato: 15 cm  
Profili "L" di alluminio inclusi

HAYA, hêtre, beech, acero  
BLANCO, blanc, white, bianco  
**477/12.** Asia  
**432/12.** EU

DM	120x120	18 mm	€/u
----	---------	-------	-----

- 
- otros colores consultar cantidad mínima 50 u.

# LAMAS - DM

**LAMA "DM" 120x120 cm**  
Regata cada 15 cm  
con perfil de aluminio

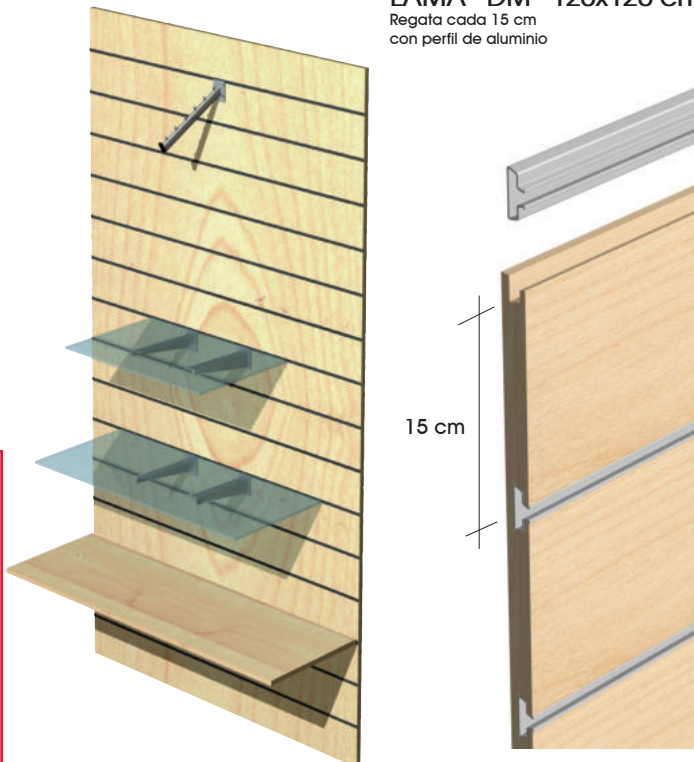

15 cm

**PASO 1**

Fresca 450/F01

**PASO 2**

Fresca 450/F00

**SE RECOMIENDA UTILIZAR AMBAS PARA PROLONGAR EL CICLO DE VIDA DE LA FRESA**

UTILIZADAS CORRECTAMENTE SU CICLO DE VIDA SE PUEDE DUPLICAR

FRESA "T" 170 mm FRAISE EN "T" 170 mm "T" MILL 170 mm FRESA A "T" 170 mm <b>450/F00</b>	Al	3,6 m	€/m	<input type="radio"/>
FRESA DIÁMETRO Ø8 FRAISE DIAMÈTRE Ø8 CUTTER DIAMETER Ø8 DIAMETRO FRESA Ø8 <b>450/F01</b>	Al	3,6 m	€/m	<input type="radio"/>

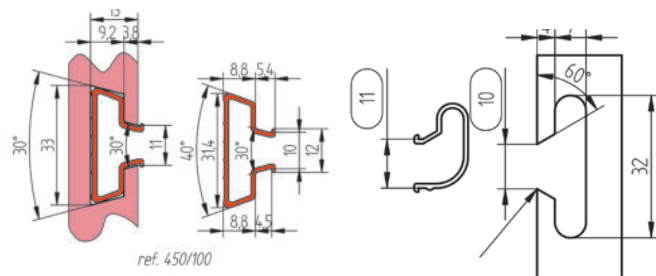

Las LAMAS tienen el terminal fresado para panelado continuo de paredes. La combinación de 2 LAMAS permite obtener una sola superficie de 2,4 x 1,2 m con 15 ranuras de aluminio, una cada 15 cm.

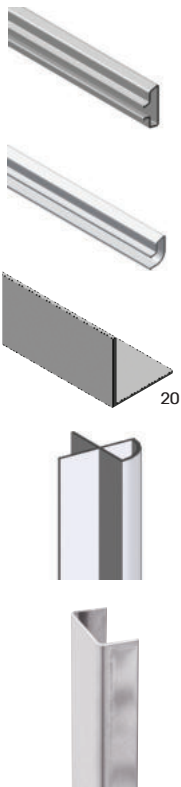
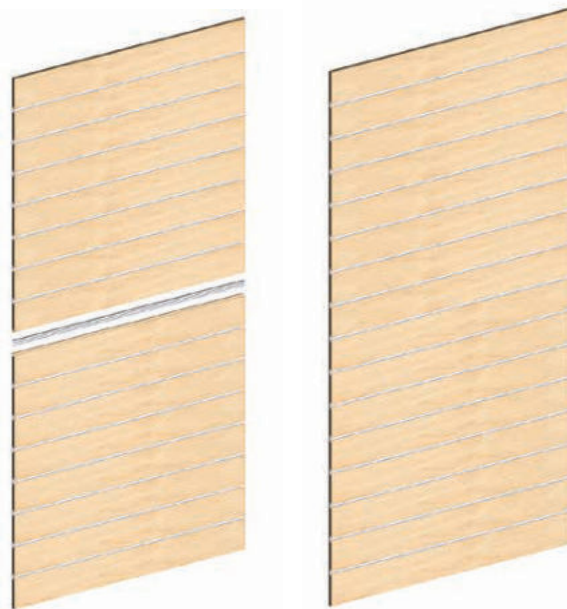

PERFIL DE ALUMINIO "T" PROFIL D'ALUMINIUM "T" ALUMINIUM PROFILE "T" PROFILO DI ALLUMINIO "T" <b>450/100 BRUTO</b>	Al	3,6 m	€/m	<input type="radio"/>
PERFIL DE ALUMINIO "L" PROFIL D'ALUMINIUM "L" ALUMINIUM PROFILE "L" PROFILO DI ALLUMINIO "L" <b>451/120 BRUTO</b>	Al	1,2 m	€/u	<input type="radio"/>
ÁNGULO 20x20 mm PROFIL EN "L" 20X20 PROFIL "L" SHAPE 20X20 PROFILO ANGOLARE 20X20 <b>1651/1..</b>	Al	5 m	€/m	<input type="radio"/> <input type="radio"/> <input type="radio"/> <input type="radio"/>
PERFIL ESQUINERO PROFIL ANGULAIRE ANGULAR PROFIL PROFILO ANGOLARE <b>*421/1..</b>	Al	2,4 m	€/m	<input type="radio"/> <input type="radio"/> <input type="radio"/>
PERFIL LATERAL "U" INOX PROFIL FINAL "U" INOX END PROFIL "U" INOX PROFILO TERMINALE "U" INOX <b>*4378/122</b>	inox s.s.	2,4 m	10x23x10x1 €/m	<input type="radio"/>

INOX BR  
INOX POLI  
P.S.S.  
INOX LUC  
**22**

# LAMAS - ALUMINIO

BLANCO	NEGRO	COLOR	PL. M
BLANC	NOR	COULEUR	ALU. M
WHITE	BLACK	COLOR	ALU. M
Bianco	Nero	COLORE	ALL. NAT
OB	ON	OP	01

# LAMAS - ALUMINIO

## LAMAS DE ALUMINIO

**LAMA aluminio regata cada 75 mm**  
Rainure chaque 75 mm - Slot every 75 mm - Slot ogni 75 mm

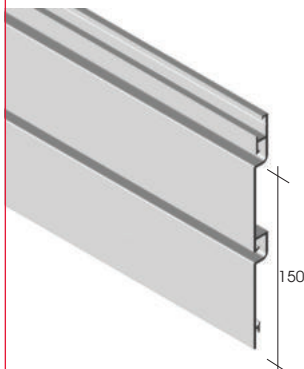

LAMA ALUMINIO "LISA"  
REGATA CADA 75 mm  
PROFIL LAME D'ALUMINIUM  
Rainure chaque 75 mm  
ALUMINIUM SLATWALL PROFILE  
Slot every 75 mm  
PROFILO DOGATO ALLUMINIO  
Slot ogni 75 mm  
427/1..

Al	5 m	178x12,5	€/m
----	-----	----------	-----

○ ○ ○ ○

**LAS LAMAS 427 Y 429 SE PUEDEN INTERCALAR ENTRE SI**  
LES PROFILS 427 ET 429 PEUVENT ÊTRE INTERCALÉES ENTRE EUX  
THE PROFILES 427 AND 429 CAN BE INTERSPERSED BETWEEN THEM  
I PROFILI 427 E 429 POSSONO ESSERE INTERVALLATI TRA LORO

**LAMA aluminio regata cada 37,5 mm**  
Rainure chaque 37,5 mm - Slot every 37,5 mm - Slot ogni 37,5 mm

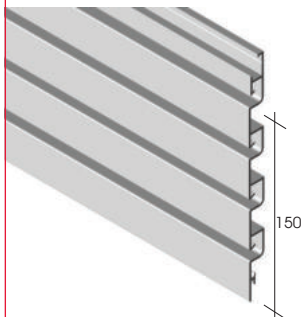

LAMA ALUMINIO.  
REGATA CADA 37,5 mm  
PROFIL LAME D'ALUMINIUM  
Rainure chaque 37,5 mm  
ALUMINIUM SLATWALL PROFILE  
Slot every 37,5 mm  
PROFILO DOGATO ALLUMINIO  
Slot ogni 37,5 mm  
429/1..

Al	5 m	178x12,5	€/m
----	-----	----------	-----

○ ○ ○ ○

**LAS LAMAS 427 Y 429 SE PUEDEN INTERCALAR ENTRE SI**  
LES PROFILS 427 ET 429 PEUVENT ÊTRE INTERCALÉES ENTRE EUX  
THE PROFILES 427 AND 429 CAN BE INTERSPERSED BETWEEN THEM  
I PROFILI 427 E 429 POSSONO ESSERE INTERVALLATI TRA LORO

## REMATES Y SOPORTES



REMATE SUPERIOR  
PARA 427 Y 429  
PROFIL SUPÉRIEUR DE FINITION  
Pour 427 and 429  
FINISHING UPPER PROFILE  
For 427 and 429  
PROFILO SUPERIORE DI FINITURA  
Per 427 e 429  
426/1..

Al	5 m	30x12,5	€/m
----	-----	---------	-----

○ ○ ○ ○

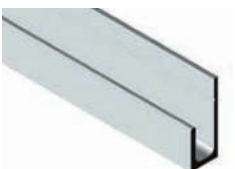

PERFIL SOPORTE INFERIOR  
PARA 427 Y 429  
PROFIL INFÉRIEUR DE SUPPORT  
Pour 427 and 429  
LOWER SUPPORT PROFILE  
For 427 and 429  
PROFILO INFERIORE DI SUPPORTO  
Per 427 e 429  
424/1..

Al	5 m	28x11	€/m
----	-----	-------	-----

○ ○ ○ ○

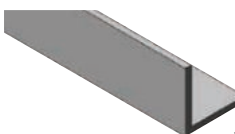

ÁNGULO 15x15 mm  
PROFIL EN "L" 15X15  
PROFIL "L" SHAPE 15X15  
PROFILO ANGOLARE 15X15  
1650/1..

Al	6,4 m	15x15x1,5	€/m
----	-------	-----------	-----

○ ○ ○ ○

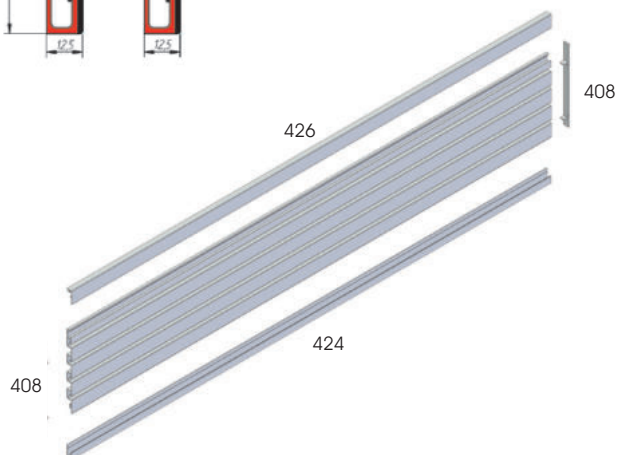
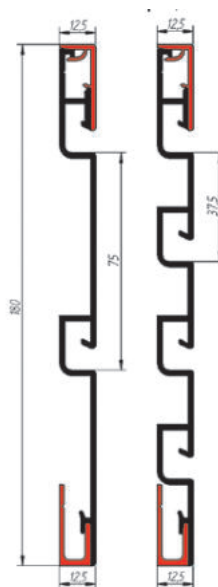
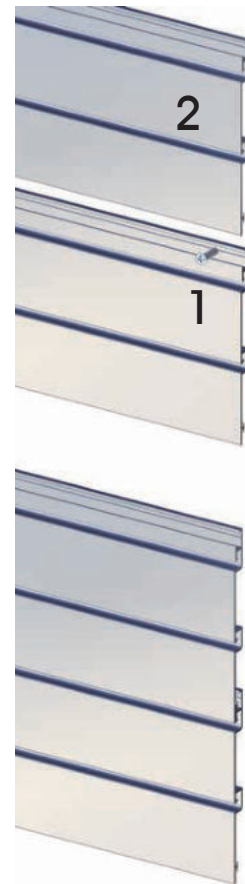
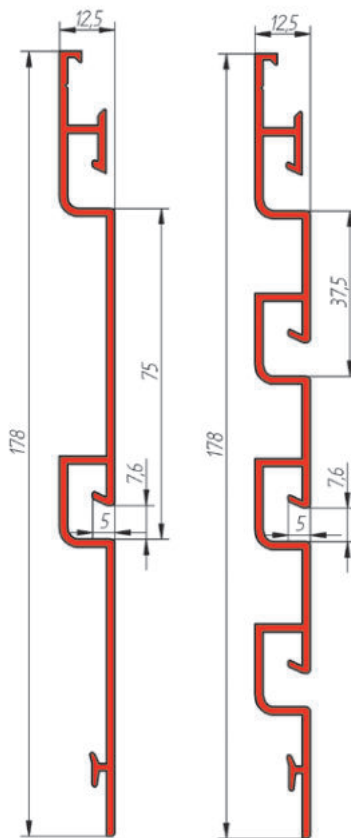



# LAMAS - ACCESORIOS

ACCESORIOS HIERRO - ACCESSOIRES EN FER  
IRON FITTINGS - ACCESSORI FERRO

CR. BRILLO CH. POLI BR. CHR. CR. LUC.	BLANCO BLANC WHITE BIANCO	NEGRO NOIR BLACK NERO	COLOR COULEUR COLOR COLORE
32	OB	ON	OP

## ACCESORIOS DE HIERRO



**GANCHO**  
CROCHET  
HOOK  
BARRETTA  
418/X.. 10 cm  
417/X.. 15 cm  
446/X.. 20 cm  
414/X.. 30 cm

Fe			€/u
	o	o	o
	o	o	o
	o	o	o
	o	o	o



**GANCHO PORTAPRECIO**  
CROCHET PORTAPRIX  
HOOK LABEL-HOLDER  
BARRETTA PORTAPREZZO  
326/X.. 15 cm  
327/X.. 20 cm  
328/X.. 25 cm  
329/X.. 10 cm

Fe	∞ 382		€/u
	o	o	o
	o	o	o
	o	o	o
	o	o	o



**GANCHO**  
CROCHET  
HOOK  
BARRETTA  
445/X.. 20 cm

Fe			€/u
	o	o	o



**GANCHO PORTAPRECIO**  
CROCHET PORTAPRIX  
HOOK LABEL-HOLDER  
BARRETTA PORTAPREZZO  
447/X.. 20 cm

Fe	∞ 382		€/u
	o	o	o



**GANCHO**  
CROCHET  
HOOK  
BARRETTA  
\*448/X.. 20 cm

Fe			€/u
	*o	*o	*o



**GANCHO**  
CROCHET  
HOOK  
BARRETTA  
441/X.. 20 cm  
442/X.. 15 cm

Fe			€/u
	o	o	o
	o	o	o



**GANCHO PORTAPRECIO**  
CROCHET PORTAPRIX  
HOOK LABEL-HOLDER  
BARRETTA PORTAPREZZO  
381/X.. 15 cm  
380/X.. 25 cm

Fe	∞ 382		€/u
	o	o	o
	o	o	o



**PORTAPRECIO**  
PORTAPRIX  
LABELHOLDER  
PORTAPREZZO  
382/009

plas	40x50 mm		€/u
			o



**BLOQUEO GANCHO**  
BLOCAGE BROCHE  
HOOK SECURITY LOCK  
BLOCCO SICUREZZA GANCIO  
373/00N

plas	∅6 mm		€/u
			o



**BLOQUEO GANCHO DOBLE**  
BLOCAGE BROCHE DOUBLE  
DOUBLE HOOK SECURITY LOCK  
BLOCCO GANCIO DOPPIO  
383/00N

plas	∅6 mm		€/u
			o



**IMÁN ESPECIAL DESBLOQUEO**  
UNLOCK MAGNET  
UNLOCK MAGNET  
MAGNETE DI SBLOCCO  
384/000

plas	373-383/00N		€/u
			o



**CARTELA ESTANTE VIDRO**  
SUPPORT TABLETTES VERRE  
GLASS SHELF BRACKET  
MENSOLA RIPIANO VETRO  
488/X.. derecha  
droite/right/destra  
487/X.. izquierda  
gauche/left/sinistra

Fe	8-10 mm		€/u
	o	o	o
	o	o	o



**CARTELA ESTANTE VIDRO**  
SUPPORT TABLETTES VERRE  
GLASS SHELF BRACKET  
MENSOLA RIPIANO VETRO  
482/X.. derecha  
droite/right/destra  
483/X.. izquierda  
gauche/left/sinistra

Fe	8-10 mm		€/u
	o	o	o
	o	o	o

# LAMAS - ACCESORIOS

ACCESORIOS HIERRO - ACCESSOIRES EN FER  
IRON FITTINGS - ACCESSORI FERRO

CR. BRILLO CH. POLI BR. CHR. CR. LUC.	BLANCO BLANC WHITE BIANCO	NEGRO NOIR BLACK NERO	COLOR COULEUR COLOR COLORE
32	OB	ON	OP



**CARTELA ESTANTE MADERA**  
SUPPORT TABLETTES BOIS  
WOOD SHELF BRACKET  
MENSOLA RIPIANO LEGNO  
489/X.. derecha  
droite/right/destra  
490/X.. izquierda  
gauche/left/sinistra

Fe	19 mm		€/u
	o	o	o
	o	o	o



**CARTELA ESTANTE MADERA**  
SUPPORT TABLETTES BOIS  
WOOD SHELF BRACKET  
MENSOLA RIPIANO LEGNO  
480/X.. derecha  
droite/right/destra  
484/X.. izquierda  
gauche/left/sinistra

Fe	250 mm		€/u
	o	o	o
	o	o	o



**PERROQUET INCLINADO**  
PERROQUET INCLINÉE  
SLOPING ARM  
APPENDERIA INCLINADA  
465/X..

Fe	300 mm		€/u
	o	o	o



**PERROQUET PLANO**  
PENDERIE FRONTAL  
STRAIGHT ARM  
APPENDERIA FRONTALE  
472/X..

Fe	300 mm		€/u
	o	o	o



**PERROQUET PLANO "Z"**  
PENDERIE FRONTAL "Z"  
STRAIGHT ARM "Z"  
APPENDERIA FRONTALE "Z"  
469/X..

Fe	350 mm		€/u
	o	o	o



**BARRA PENDERIE**  
BARE PENDERIE  
HANGING BAR  
BARRA APPENDERIA  
459/X..

Fe	90X30 cm	12 kg/u	€/u
	o	o	o



**SOPORTE CORBATERO**  
SUPPORT TIE RACK  
SUPPORT PORTE-CRAVATES  
SUPPORTO PORTACRAVATTE  
473/X..

Fe	∅ 342 mm		€/u
	o	o	o



**SOPORTE CASCO**  
HELMET SUPPORT  
SUPPORT CASQUE MOTO  
SUPPORTO CASCO  
462/X..

Fe	∅ 116 mm		€/u
	o	o	o

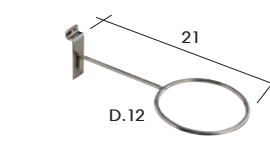

**SOPORTE PELOTA**  
BALL SUPPORT  
SUPPORT DE BALLON  
SUPPORTO PALLA  
461/X..

Fe	∅ 130 mm		€/u
	o	o	o

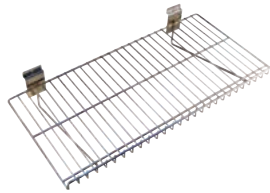

**ESTANTE REJILLA**  
FLAT GRID SHELF  
ÉTAGÈRE PLAN DE GRILLE  
RIPIANO GRIGLIA  
464/X..

Fe	600x310 mm		€/u
	o	o	o

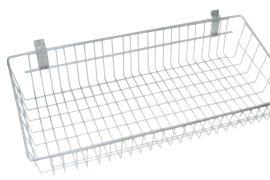

**CESTA REJILLA**  
GRID BASKET  
PANIER DE GRILLE  
CESTINO GRIGLIA  
463/X..

Fe	600x310 mm		€/u
	o	o	o



# PARALELO

# 384

Empotrable, fijación a panel  
 Para estantes de 5, 6 mm ó 8 mm  
 Peso max. recomendado: 20 kg/ml (ver instrucciones)

ENCASTRÉ, MONTAGE SUR PANNEAU  
 TABLETTE 5, 6 ou 8 mm  
 POIDS MAX. RECOMMANDÉE: 20 kg / ml (VOIR LES INSTRUCTIONS)

EMBEDDED, PANEL MOUNTING  
 SHELF 5, 6 mm or 8 mm  
 MAX. RECOMMENDED: 20 kg / ml (SEE INSTRUCTIONS)

A INCASSO, MONTAGGIO A PANNELLO  
 SHELF 5, 6 O 8 mm  
 PESO MASS. CONSIGLIATO: 20 kg / ml (VEDI ISTRUZIONI)

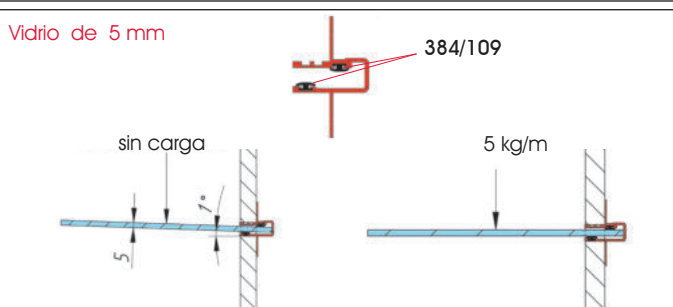
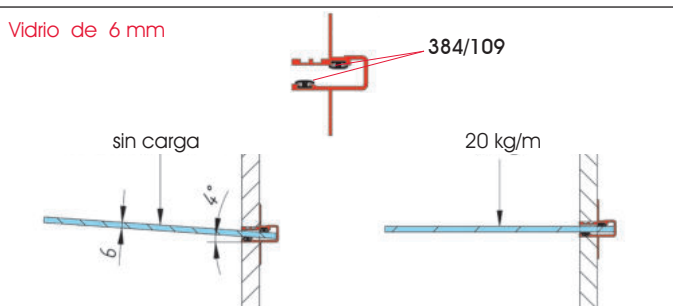
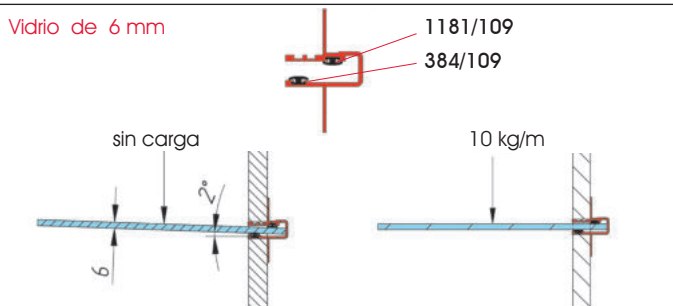
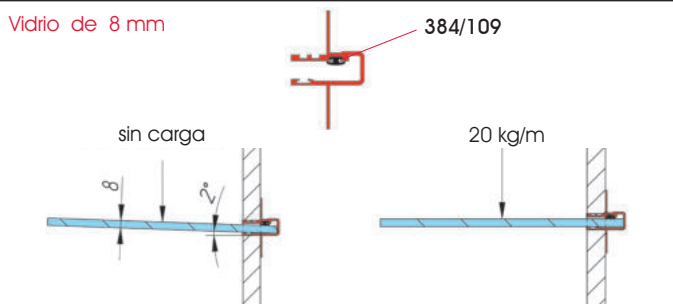

## MONTAJE

MONTAGE, MOUNTING, MONTAGGIO

Debido a la deformación de las gomas por acción del peso soportado por el estante, se recomienda combinar distintos espesores de vidrio+gomas en relación al peso previsto.  
 NOTA: Se recomienda utilizar estantes de vidrio de seguridad (según la normativa en espacios públicos y para una mayor resistencia).

*En raison de la déformation du caoutchouc par l'action du poids supporté par la tablette, il est recommandé de combiner différentes épaisseurs de verre + caoutchouc en rapport de poids attendu.*

*NOTE: Nous vous recommandons d'utiliser tablettes en verre de sécurité (en vertu des règles dans les espaces publics et pour plus de solidité).*

Due to deformation of the rubbers by the action of weight supported by the shelf, it is recommended to combine various glass thicknesses + rubbers depending on the weight expected.

NOTE: We recommend using safety glass shelves (under the rules in public spaces and for greater resistance).

A causa della deformazione delle gomme per l'azione del peso sostenuto dal ripiano, si consiglia di combinare vari spessori vetro + gomme in relazione al peso previsto.

NOTA: Si consiglia utilizzare ripiani di vetro di sicurezza (nel rispetto delle norme in spazi pubblici e per una maggior resistenza).

Para un estante de 80 cm (max. recomendado):  
 Pour une étagère de 80 cm (max. recommandé): 80 cm  
 For a shelf 80 cm long (max. recommended): 80cm  
 Per un ripiano di 80 cm di lunghezza (massimo raccomandato): 80 cm

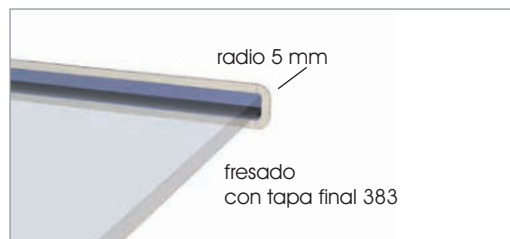
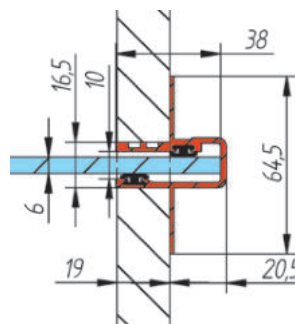



# PARALELO 384

# PARALELO 384

PL. M	COLOR	BLANCO	NEGRO	CR. BRILLO
ALU. M	COULEUR	BLANC	NOIR	CR. POLI
ALU. M	COLOR	WHITE	BLACK	BR. CHR
ALL. NAT	COLORE	BIANCO	NERO	CR. ILLC.

01	0P	0B	0N	32
----	----	----	----	----

Al	5 m	5/6/8 mm
----	-----	----------

∞ 384/1181				

plac	∞ 384	€/m		
------	-------	-----	--	--

plac	∞ 384	€/m		
------	-------	-----	--	--

plac	∞ 384	€/u		
------	-------	-----	--	--

Fe		€/u		
----	--	-----	--	--

Fe		€/u		
----	--	-----	--	--



Fe		€/u		
----	--	-----	--	--







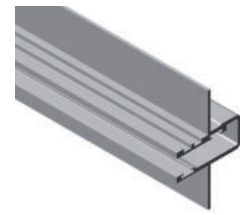
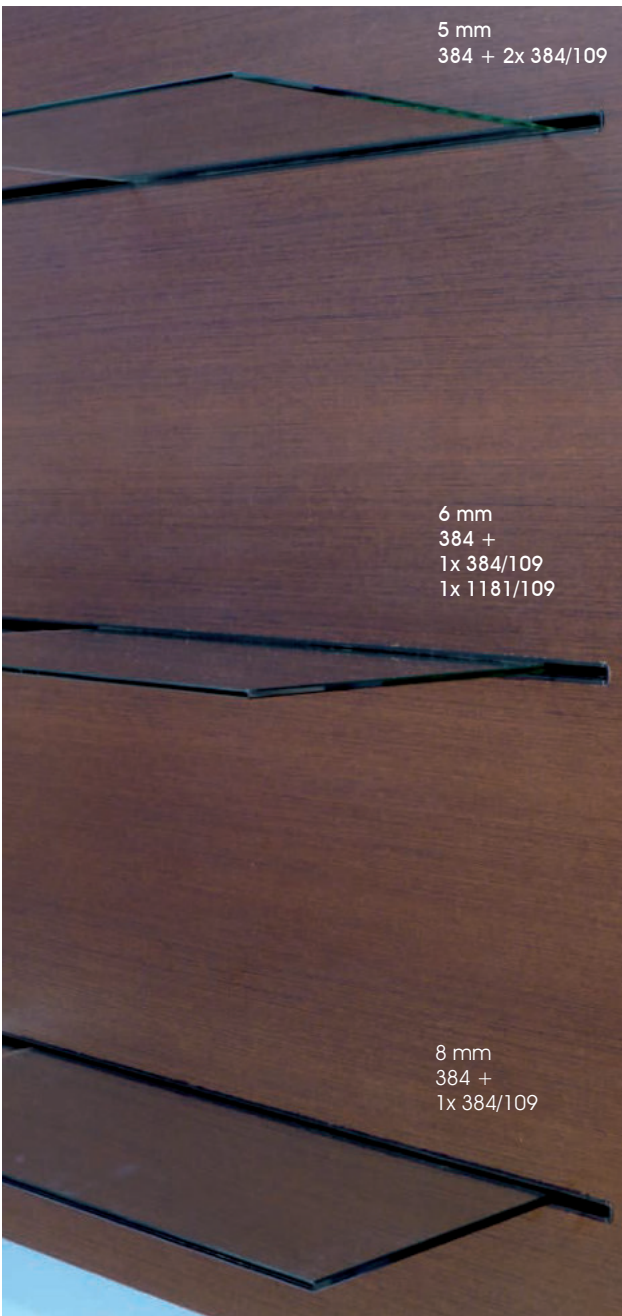

**PERFIL INVISIBLE**  
PROFIL D'ALUMINIUM  
ALUMINIUM PROFILE  
PROFILO DI ALLUMINIO  
**384/1..**



**GOMA DURA**  
CAOUTCHOUC DUR  
HARD RUBBER  
GOMMA DURA  
**384/109**

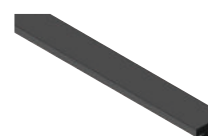

**GOMA BLANDA**  
CAOUTCHOUC SOUPLE  
SOFT RUBBER  
GOMMA MORBIDA  
**1181/109**



**TAPA FINAL**  
CABOCHON profil 384  
END-CAP 384 profile  
COPRITESTA profilo 384  
**383/00P** GRIS  
**383/TON** NEGRO



**GANCHO**  
BROCHE  
HOOK  
BARRETTA  
**\*377/0..** 20 cm



**GANCHO SEGURIDAD**  
DOUBLE BROCHE  
DOUBLE HOOK  
BARRETTA DOPPIA  
**\*378/0..** 20 cm



**GANCHO GAFAS**  
SUPPORT FOR GLASSES  
SUPPORT POUR LUNETTES  
BARRETTA PER OCCHIALI  
**\*379/0..**

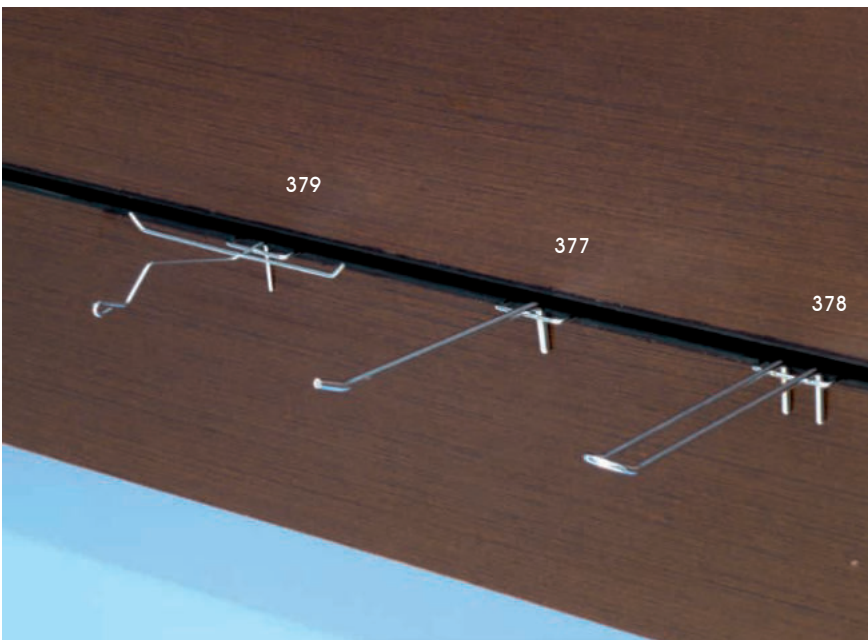

# OPTI 3

## PERFIL INVISIBLE PARA ESTANTES Y ACCESORIOS DE 3MM DE ESPESOR.

SISTEMA MACHIHEMBADO  
 SYSTÈME EMBOÏTEMENT  
 SOCKET JOINT SYSTEM  
 SISTEMA A INCASTRO

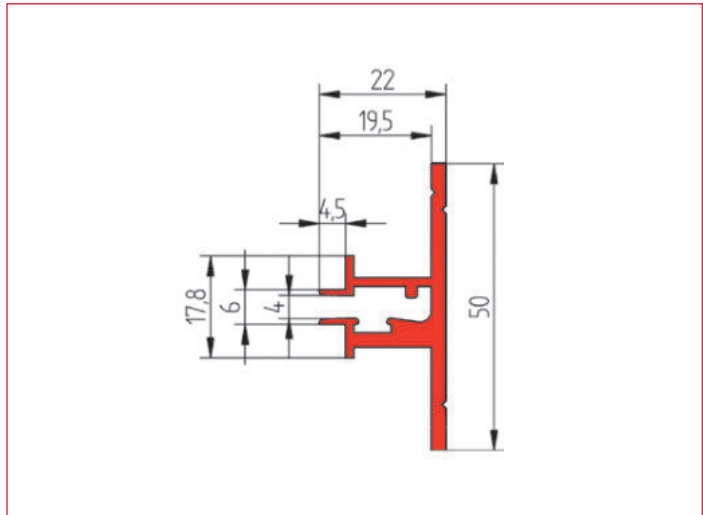

**PERFIL INVISIBLE PARA ESTANTES DE 3 MM DE ESPESOR**  
 PROFIL INVISIBLE POUR ÉTAGÈRES 3 MM D'ÉPAISSEUR  
 INVISIBLE PROFILE FOR SHELVES 3 MM THICK  
 PROFILO INVISIBLE PER RIPIANI DI 3 MM DI SPESSORE  
**360/1..**

BLANCO	NEGRO	COLOR	PL. M
BLANC	NOIR	COULEUR	ALU. M
WHITE	BLACK	COLOR	ALL. M
BIANCO	NERO	COLORE	ALL. NAT
<b>OB</b>	<b>ON</b>	<b>OP</b>	<b>O1</b>

Al	5 m	6/8 mm	€/m
----	-----	--------	-----

Fe	190x190x50 mm	€/u
----	---------------	-----

Fe	190x210 mm	€/u
----	------------	-----



**ESTANTE PLEGADO 3 MM**  
 SUPPORT-TABLETTE 3MM  
 FOLDED BRACKET-SHELF 3 MM  
 MENSOLA-RIPIANO PIEDATA 3 MM  
**387/0..**

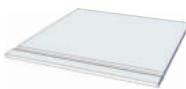

**BANDEJA SIMPLE 3 MM**  
 SUPPORT-TABLETTE 3MM  
 BRACKET-SHELF 3 MM  
 MENSOLA-RIPIANO 3 MM  
**388/0..**

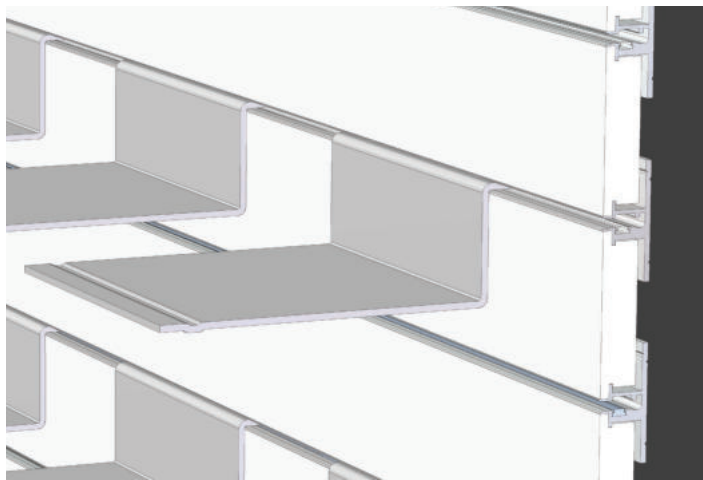

# OPTI-3

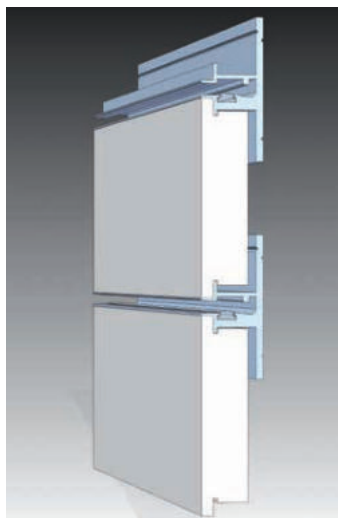

Madera 16 mm

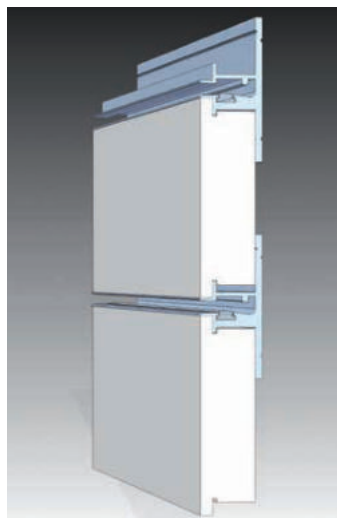

Madera 19 mm

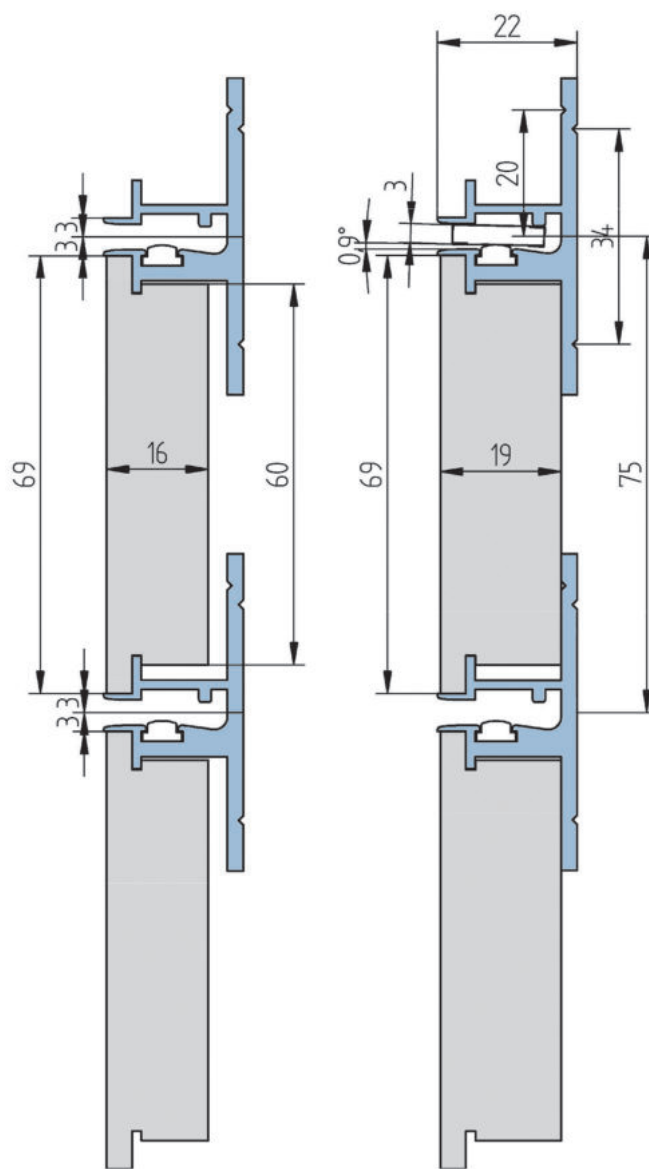
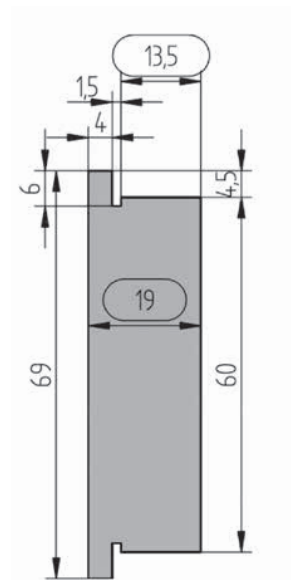
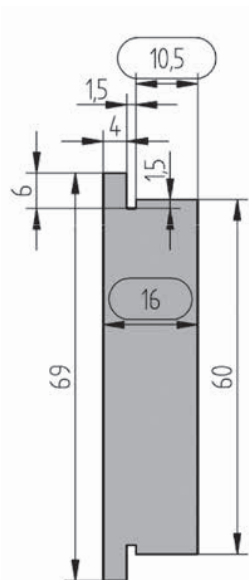

Madera 19 mm

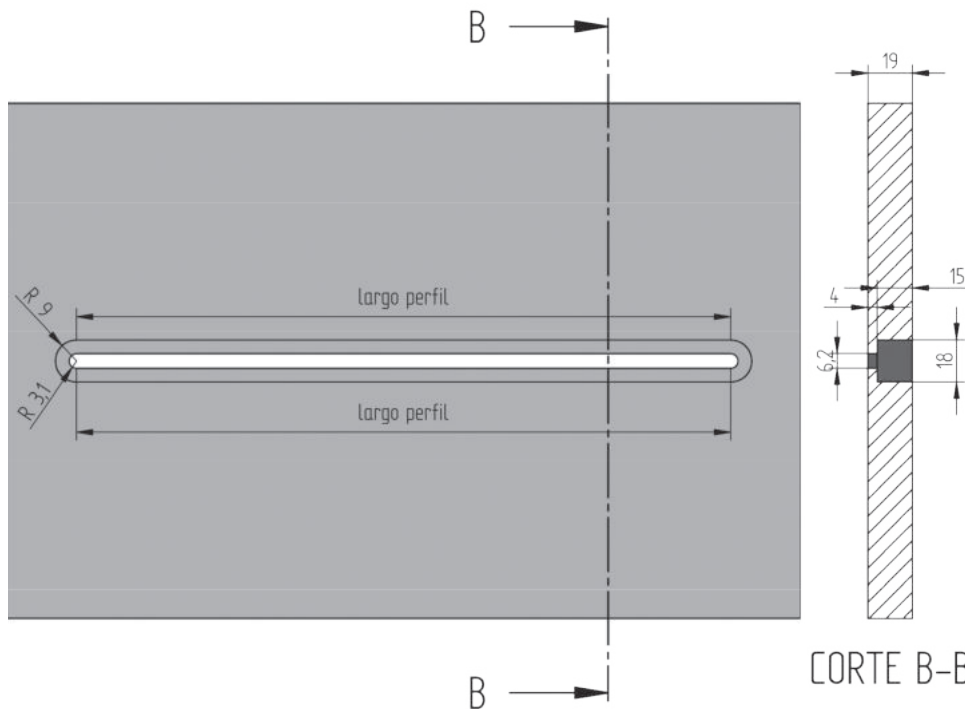



**INSTAL - ÍNDEX****MULTILAMA - VERTICAL**

<b>1- PERFIL MULTILAMA</b>	<b>113</b>
Perfil multilama paso 12,5 mm y accesorios	
<b>2- VERTICAL</b>	<b>117</b>
Sistema tubular con accesorios comunes con Multilama	

# MULTILAMA

LAMA DE ALUMINIO PASO 12,5 MM

PROFIL LAME D'ALUMINIUM

ALUMINIUM SLATWALL PROFILES STEP 12,5 MM

PROFILI DOGATI DI ALLUMINIO PASSO 12,5 MM

## ACCESORIOS SOLO PARA MULTILAMA Y VERTICAL

ACCESSOIRES SEULEMENT POUR MULTILAMA ET VERTICAL

ACCESSORIES ONLY FOR MULTILAMA AND VERTICAL

ACCESSORI SOLO PER MULTILAMA E VERTICALE



# MULTILAMA



## MONTAJE

1. Colocar las cremallaeras 400 a una distancia de 30-40 cm entre ellas, dependiendo de la carga a soportar.

Con paredes de Pladur se recomienda fijar las cremalleras a los montantes estructurales de la misma.

2. Se recomienda evitar colocar los accesorios con peso en la ranura de unión entre una lama y la otra.

1. Placing the racks 400 at a distance of 30-40 cm between them, depending on the load to be supported.

With plasterboard walls is recommended to set the racks to the same structural uprights.

2. Is recommended to avoid placing accessories in the slot between 2 profiles.

1. Placer les crémaillères 400 à une distance de 30 à 40 cm entre eux, en fonction de la charge à supporter.

Avec des murs en plaques de plâtre est recommandé de fixer les crémaillères pour les mêmes montants de structure.

2. Il est recommandé d'éviter de placer le poids de les accessoires en la joint de deux profils.

1. Montare i profili cremagliera a una distanza di 30-40 cm fra loro, in funzione del peso che deve sopportare. Con pareti di cartongesso, si raccomanda fissare i montanti direttamente alla struttura della stessa parete.

2. Si raccomanda evitare la collocazione degli accessori nella ranura corrispondente all'unione di 2 profili.

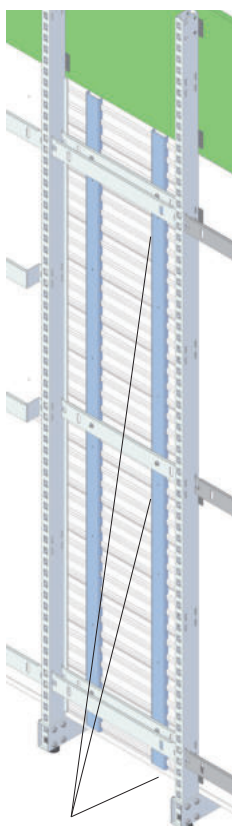

### Solución con MULTILAMA

Solution avec MULTILAMA  
Solution with MULTILAMA  
Soluzione con MULTILAMA



MONTAJE FRONTAL  
montage frontal  
front mounting  
montaggio frontale

1650/1..  
REMATE ÁNGULO 15X15  
profil lateral de finition  
lateral finishing profile  
profilo laterale di finitura

1651/1..  
REMATE ÁNGULO 20X20  
profil lateral de finition  
lateral finishing profile  
profilo laterale di finitura

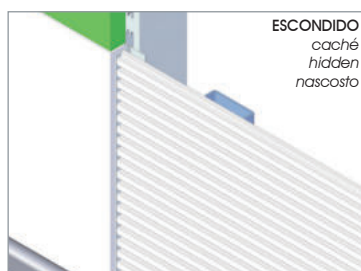

ESCONDIDO  
caché  
hidden  
nascosto

4838/000  
ANCLAJE MULTILAMA  
Support Multilama  
Support Multilama  
Supporto Multilama

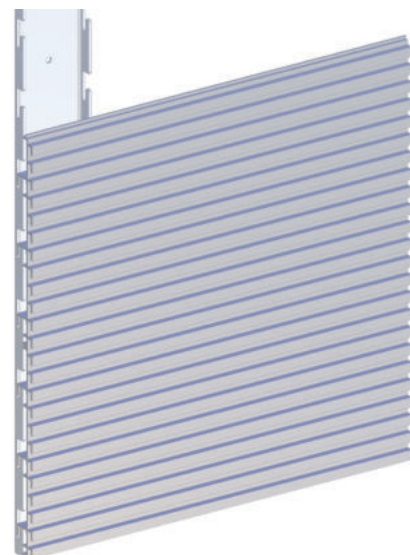
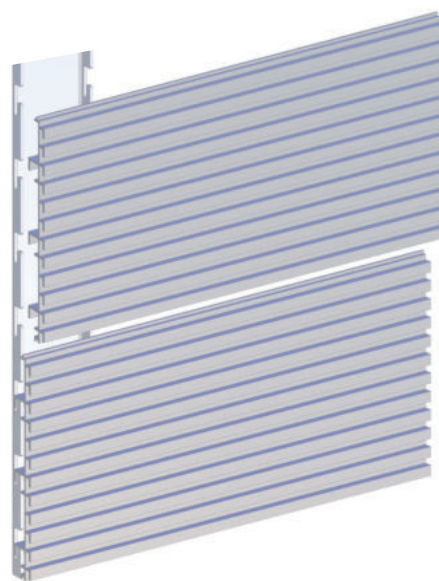

# MULTILAMA

# MULTILAMA

MULTILAMA aluminio regata cada 12,5 mm  
 Rainure chaque 12,5 mm - Slot every 12,5 mm - Slot ogni 12,5 mm

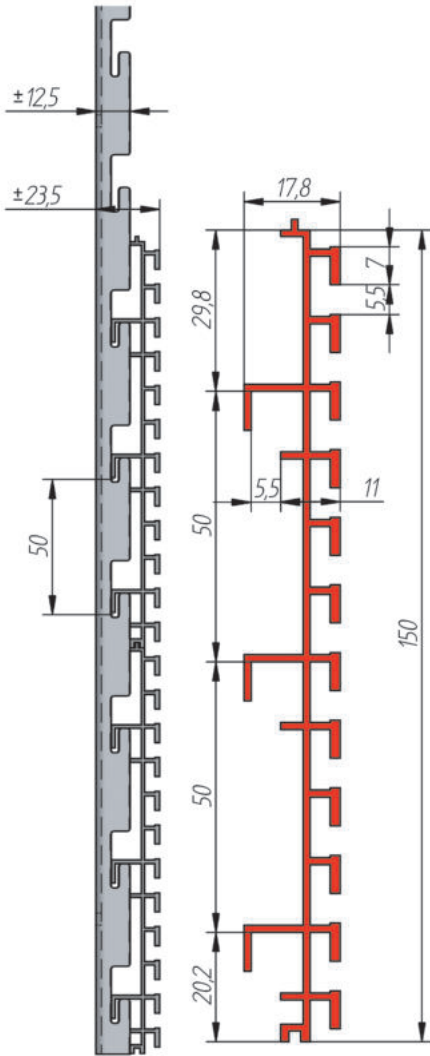

## REMATE LATERAL

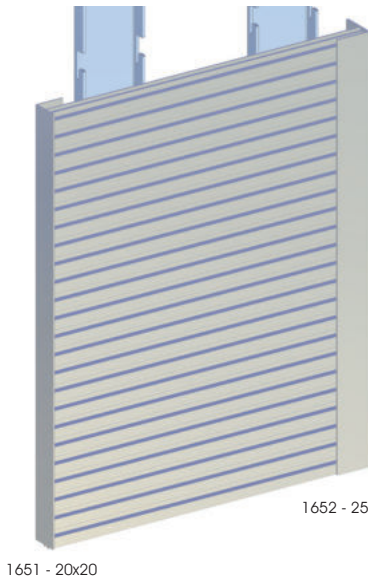

**MONTAJE FRONTAL**  
 montage frontal  
 front mounting  
 montaggio frontale  
 1652 - 25x25  
 pegada por delante

**ESCONDIDO**  
 caché  
 hidden  
 nascosto  
 1651 - 20x20  
 pegada por atrás

## ÁNGULOS Y "US"

PROFILES "L" ET "U"  
 "L" AND "U" PROFILES  
 PROFILI "L" E "U"



ÁNGULO 20x20 mm  
 PROFIL EN "L" 20X20  
 PROFIL "L" SHAPE 20X20  
 PROFILO ANGOLARE 20X20  
**1651/1..**



ÁNGULO 25x25 mm  
 PROFIL EN "L" 25X25  
 PROFIL "L" SHAPE 25X25  
 PROFILO ANGOLARE 25X25  
**1652/1..**

	PL M	ORO	M	BLANCO	NEGRO	COLOR	BRUTO
	ALU. M	DORÉ	M	BLANC	NOIR	COULEUR	BRUT
	ALU. M	GOLD	M	WHITE	BLACK	COLOR	RAW
	ALL. NAT	DOR. OP	BIANCO	NERO	COLORE	GREZZO	
	01	03	0B	0N	0P	00	
Al	5 m	20x20x1 mm					€/m
			o	o	o	o	
Al	5 m	25x25x1,5 mm					€/m
			o	o	o	o	

## GUÍA 400





# MULTILAMA

BLANCO BLANC WHITE BIANCO	NEGRO NOIR BLACK NERO	COLOR COULEUR COLOR COLORE	PL. M ALU. M ALU. M ALL. NAT
OB	ON	OP	01

# MULTILAMA

BLANCO BLANC WHITE BIANCO	NEGRO NOIR BLACK NERO	COLOR COULEUR COLOR COLORE	CR. BRILLO CH. POLI BR. CH. CR. LUC.
OB	ON	OP	32

MULTILAMA aluminio regata cada 12,5 mm  
Rainure chaque 12,5 mm - Slot every 12,5 mm - Slot ogni 12,5 mm

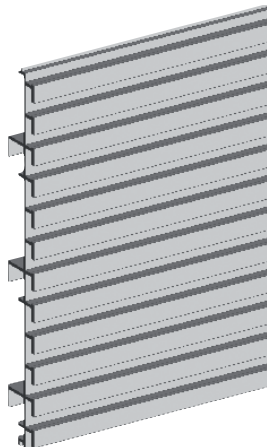

MULTILAMA ALUMINIO  
12 CANALES (12,5 MM)  
PROFIL LAME D'ALUMINIUM  
12 rainures chaque 12,5 mm  
ALUMINIUM SLAT/WALL PROFILE  
12 Slots every 12,5 mm  
PROFILO DOGATO ALLUMINIO  
12 ranure ogni 12,5 mm

Al	5 mm	∞	400	€/m

401/1..

## ACCESORIOS SOLO PARA MULTILAMA

ACCESSOIRES SEULEMENT POUR MULTILAMA  
ACCESSORIES ONLY FOR MULTILAMA  
ACCESSORI SOLO PER MULTILAMA

### Guía pared MULTILAMA



CREMALLERA PARED  
PARA PERFILES 401.. 403  
CRÉMAILLÈRE MUR  
Avec profils 403 et 401  
WALL RACK  
for profiles 403 y 401  
CREMAGLIERA PARETE  
con profili 403 e 401

Al	3 mm	∞	401-403	€/m

400/334

ZINCADO  
PL. ZINC  
ZINC PL.  
ZINCATO

34

CR. BRILLO  
CH. POLI  
BR. CH.  
CR. LUC.

32

GANCHO  
CROCHET  
HOOK  
GANCIO  
332/0.. 10 cm  
352/0.. 15 cm  
349/0.. 20 cm  
353/0.. 25 cm  
350/0.. 30 cm

Fe	∞	401	€/u

GANCHO PORTAPRECIO  
CROCHET PORTAPRIX  
HOOK LABEL-HOLDER  
GANCIO PORTAPREZZO  
334/0.. 15 cm  
338/0.. 20 cm  
348/0.. 25 cm

Fe	∞	401-382	€/u

PORTAPRECIO  
PORTAPRIX  
LABELHOLDER  
PORTAPREZZO  
382/009

plac	40x50 mm	€/u

BLOQUEO GANCHO  
BLOCAGE BROCHE  
HOOK SECURITY LOCK  
BLOCCO SICUREZZA GANCIO  
373/00N

plac	∅6 mm	€/u

BLOQUEO GANCHO DOBLE  
BLOCAGE BROCHE DOUBLE  
DOUBLE HOOK SECURITY LOCK  
BLOCCO GANCIO DOPPIO  
383/00N

plac	∅6 mm	€/u

IMÁN ESPECIAL DESBLOQUEO  
UNLOCK MAGNET  
UNLOCK MAGNET  
MAGNETE DI SBLOCCO  
384/000

plac	373-383/00N	€/u

CARTELA ESTANTE MADERA  
SUPPORT TABLETTES BOIS  
WOOD SHELF BRACKET  
MENSOLA RIPIANO LEGNO  
310/0.. derecha  
droite/right/destra  
311/0.. izquierda  
gauche/left/sinistra

Fe	19 mm	∞	401	€/u

CARTELA ESTANTE VIDRO  
SUPPORT TABLETTES VERRE  
GLASS SHELF BRACKET  
MENSOLA RIPIANO VETRO  
312/0.. derecha  
droite/right/destra  
313/0.. izquierda  
gauche/left/sinistra

Fe	8-10 mm	∞	401	€/u

CARTELA ESTANTE VIDRO  
SUPPORT TABLETTES VERRE  
GLASS SHELF BRACKET  
MENSOLA RIPIANO VETRO  
346/0.. derecha  
droite/right/destra  
347/0.. izquierda  
gauche/left/sinistra

Fe	8-10 mm	∞	401	€/u

CARTELA ESTANTE VIDRO  
SUPPORT TABLETTES VERRE  
GLASS SHELF BRACKET  
MENSOLA RIPIANO VETRO  
314/0..

Fe	8-10 mm	∞	401	€/u
	200x292 mm			

CARTELA ESTANTE MADERA  
SUPPORT TABLETTES BOIS  
WOOD SHELF BRACKET  
MENSOLA RIPIANO LEGNO  
344/0.. derecha  
droite/right/destra  
340/0.. izquierda  
gauche/left/sinistra

Fe	250 mm	∞	401	€/u

PERROQUET PLANO  
PENDERIE FRONTAL  
STRAIGHT ARM  
APPENDERIA FRONTALE  
343/0..

Fe	300 mm	∞	401	€/u

PERROQUET INCLINADO  
PERROQUET INCLINÉE  
SLOPING ARM  
APPENDERIA INCLINADA  
342/0..

Fe	300 mm	∞	401	€/u

BARRA PENDERIE  
BARRE PENDERIE  
HANGING BAR  
BARRA APPENDERIA  
351/0..

Fe	90X30 cm	∞	401	€/u
	12 kg/u			

# VERTICAL

## CARACTERÍSTICAS

- Sistema modular que se adapta a cualquier medida entre montantes
- permite montantes individuales
- Estantes de madera y vidrio de 20 a 35 cm de fondo
- Se puede pintar en cualquier color

## CARACTÉRISTIQUES - FEATURS - CARATTERISTICHE

- Système modulaire réglable pour chaque distance entre montants
- Modular system adjustable for each distance between uprights
- Sistema modulare regolabile per ogni distanza fra piantane
- Permet tube-crémallères individuels
- allows individual uprights
- permette piantane individuali
- Tablettes en bois et verre de 20 à 35 cm de profondeur
- Wooden and glass shelves of 20-35 cm deep
- Ripiani di legno e vetro da 20 a 35 cm di fondo
- Il peut être peint dans toutes les couleurs
- It can be painted in any color
- si può verniciare in qualsiasi colore



# VERTICAL

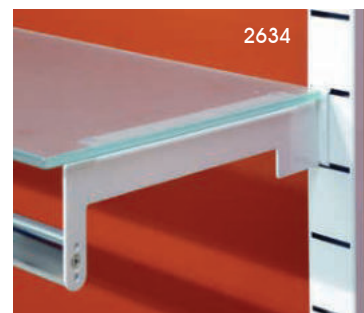

# VERTICAL

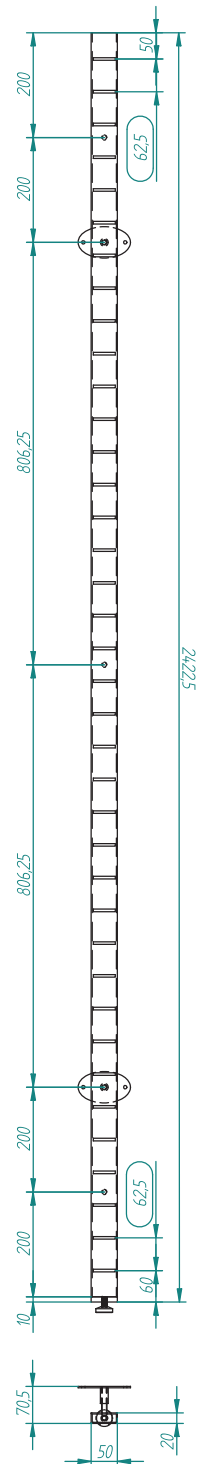
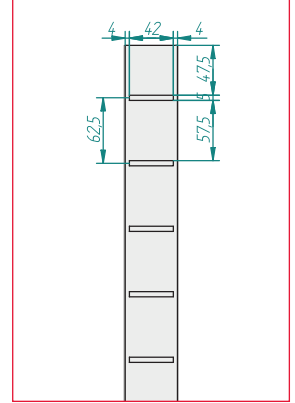

# VERTICAL

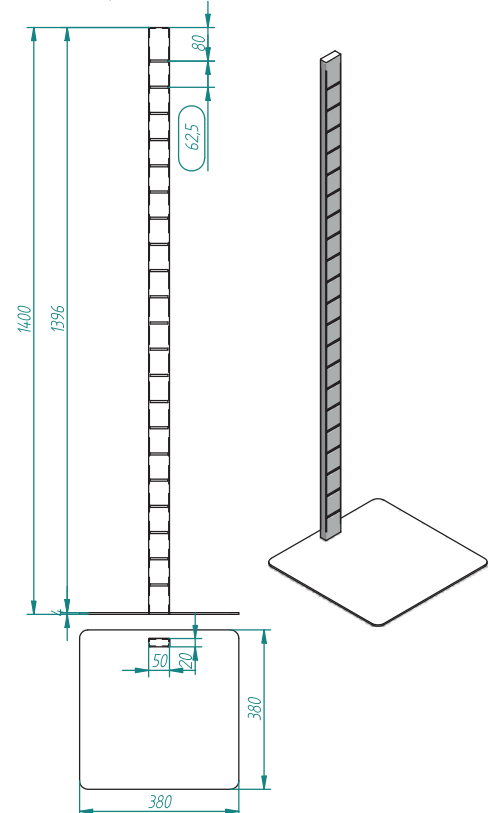
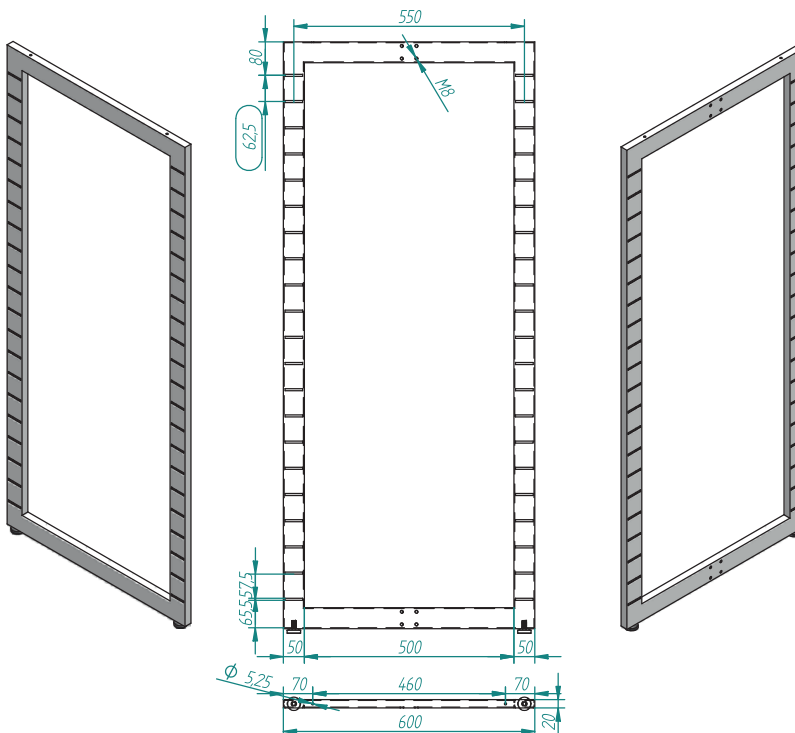
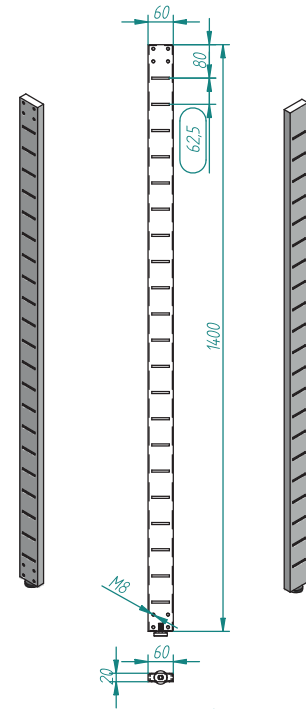
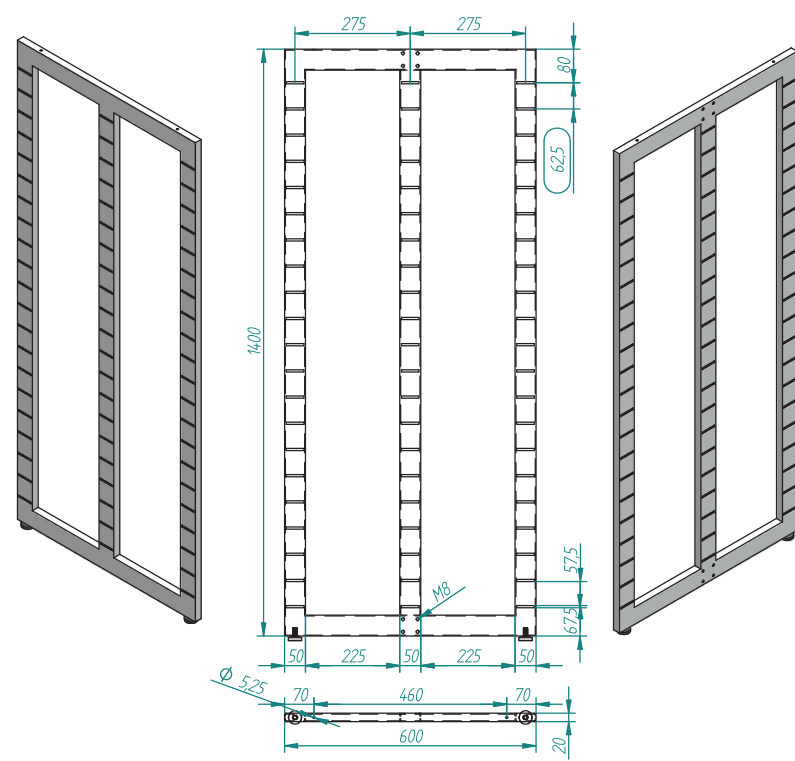
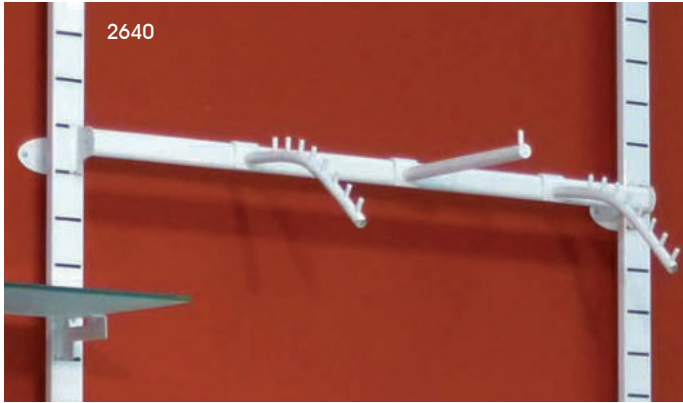



## VERTICAL

### 1. Montaje a pared

Sistema modular que se adapta a cualquier medida de eje entre montantes.

**MONTAGE MURAL** Système modulaire réglable pour chaque distance entre montants

**WALL MOUNTING** Modular system adjustable for each distance between uprights

**MONTAGGIO A PARETE** Sistema modulare regolabile per ogni distanza fra piantane

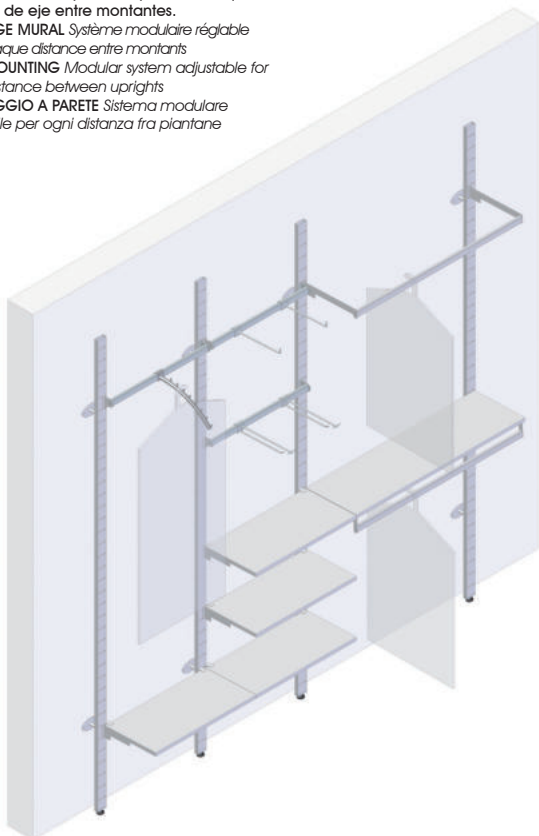

### 2. Montaje a pared

Total libertad de combinación compoditiva con estantes repartidos entre montantes o estantes individuales

**MONTAGE MURAL** tablettes divisées entre les poteaux ou étagères individuelles

**WALL MOUNTING** shelves divided between uprights or individual shelves

**MONTAGGIO A PARETE** ripiani condivisi fra piantane o scaffalature individuali

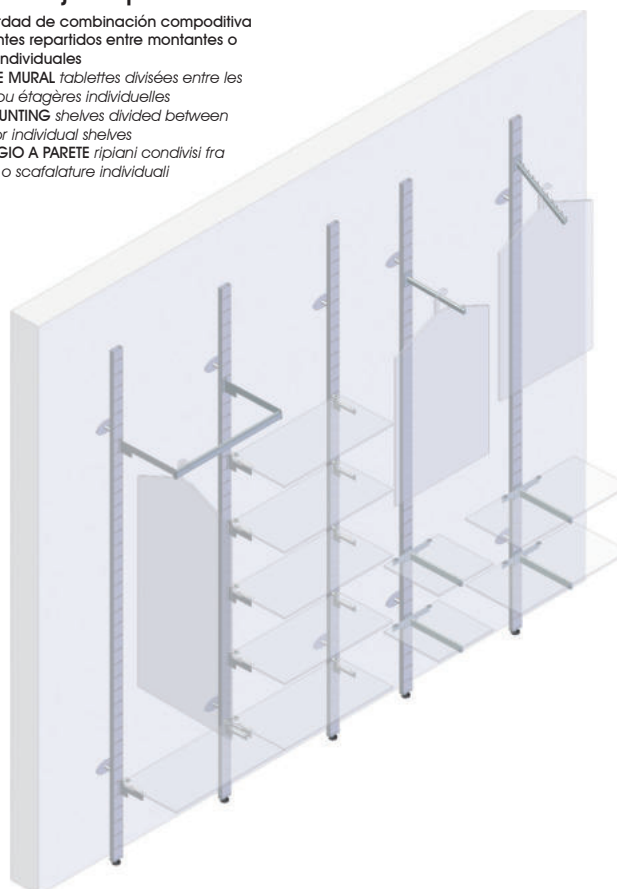

### 3. Montaje a pared

Posibilidad de usar montantes individuales con accesorios del sistema Multilamas.

**MONTAGE MURAL** Permet tube-crémallères individuels avec accessoires MULTILAMA

**WALL MOUNTING** allows individual uprights with MULTILAMA fittings

**MONTAGGIO A PARETE** permette piantane individuali con accessori MULTILAMA



### 4. Display autoportante

Múltiples combinaciones para hacer góndolas

*Multiple combinations pour displays autoportantes*

*Multiple combinations for displays self-supporting*

*Combinazioni multiple per displays autoportanti*

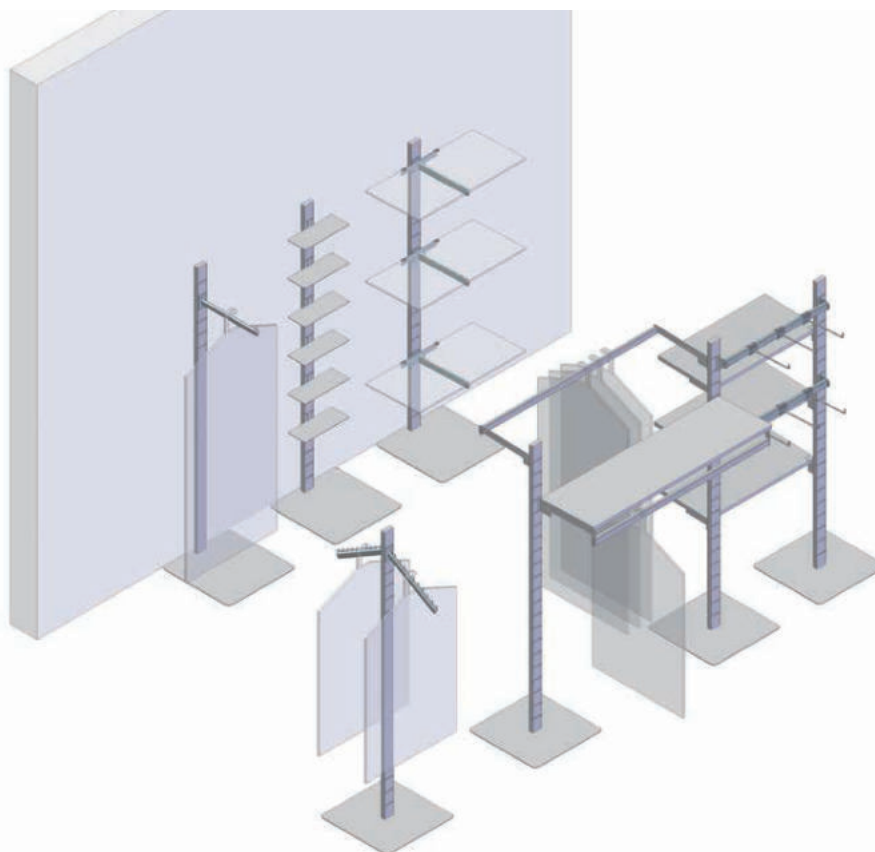

# VERTICAL

## 5. Góndola

Múltiples combinaciones para hacer góndolas  
 Multiples combinaisons pour gondoles  
 Multiple combinations for gondolas  
 Combinazioni multiple per gondole



6.

7.

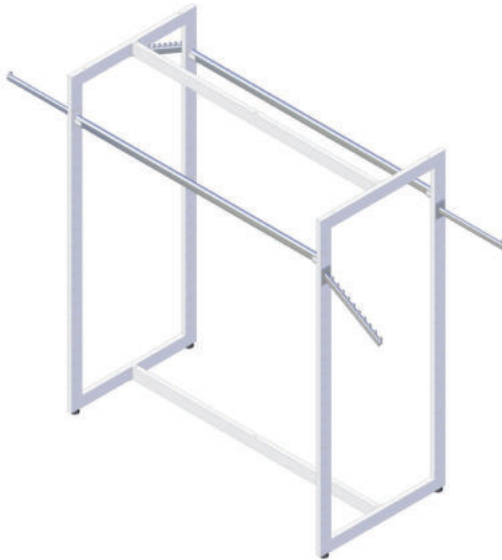

8.



9.



10.

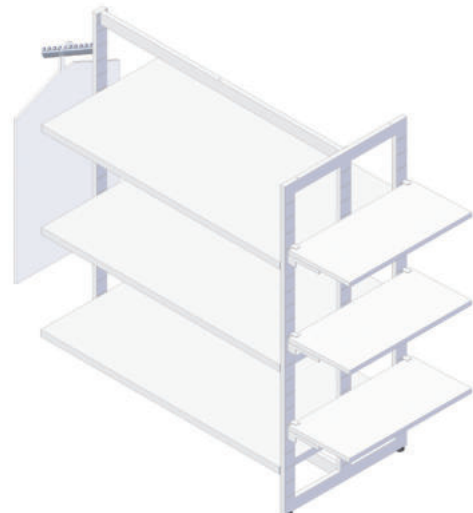



# VERTICAL

BLANCO	NEGRO	COLOR	ZINCADO
BLANC	NOIR	COULEUR	PL. ZNK
WHITE	BLACK	COLOR	ZNK PL.
BIANCO	NERO	COLORE	ZINCATO
OB	ON	OP	34



**GUÍA CREMALLERA**  
CRÉMAILLÈRE  
UPRIGHT  
MONTANTE CREMALLERA  
Niveladores a pared y suelo  
Niveleurs au mur et au sol  
Livellatori a muro e suolo  
**2640/0..**

Fe	50x20x2425	€/u
----	------------	-----

--	--	--	--



**CARTELA ESTANTE MADERA**  
SUPPORT TABLETTE EN BOIX  
BRACKET FOR WOOD SHELF  
MENSOLA RIPIANO LEGNO  
**2630/0.. der.**  
droite/right/destra  
**2631/0.. izq.**  
gauche/left/sinistra

Fe	19 mm	€/u
----	-------	-----

--	--	--	--



**CARTELA ESTANTE VIDRIO**  
SUPPORT TABLETTE VERRE  
BRACKET FOR GLASS SHELF  
MENSOLA RIPIANO VETRO  
**2632/0.. der.**  
droite/right/destra  
**2633/0.. izq.**  
gauche/left/sinistra

Fe	8-10 mm	€/u
----	---------	-----

--	--	--	--



**CARTELA PARA ESTANTE DE MADERA O VIDRIO Y BARRA CONFECCIÓN**  
SUPPORT BARRE PENDERIE + TABLETTE VERRE ET BOIX  
BRACKET FOR HANGING BAR + GLASS OR WOOD SHELF  
MENSOLA BARRA APPENDERIA + RIPIANO VETRO O LEGNO  
min: 35 cm  
**2634/0.. der.**  
droite/right/destra  
**2635/0.. izq.**  
gauche/left/sinistra

Fe	∅4347	€/u
----	-------	-----

--	--	--	--



**CARTELA BARRA CONFECCIÓN**  
SUPPORT BARRE PENDERIE  
BRACKET FOR HANGING BAR  
MENSOLA BARRA PENDERIA  
**2636/0.. der.**  
droite/right/destra  
**2637/0.. izq.**  
gauche/left/sinistra

Fe	∅4547	€/u
----	-------	-----

--	--	--	--



**CARTELA BARRA ACCESORIOS**  
SUPPORT BARRE ACCESSOIRES  
BRACKET FOR ACCESSORIES BAR  
MENSOLA BARRA ACCESSORI  
**2638/0.. der.**  
droite/right/destra  
**2639/0.. izq.**  
gauche/left/sinistra

Fe	∅4547	€/u
----	-------	-----

--	--	--	--



**TORNILLO-EMBELLECEDOR**  
DISQUE DE FINITION  
STUD SCREW  
DISCO VITE  
**4720/0..**

Fe	∅4547	€/u
----	-------	-----

--	--	--	--

# VERTICAL

CR. BRILLO	CR. MATE	BLANCO	NEGRO	COLOR
CHR. POLI	CHR. M	BLANC	NOIR	COULEUR
CR. CHR	M. CHR	WHITE	BLACK	COLOR
CR. LUC.	CR. OPAC	BIANCO	NERO	COLORE
32	31	OB	ON	OP



**TUBO CUELGA**  
TUBE PENDERIE  
TUBE HANGING BAR  
TUBO PENDERIA  
**4547/1..**

Fe	3 m	36x18x1,5	€/m
----	-----	-----------	-----

--	--	--	--



**PERROQUET PLANO**  
PENDERIE FRONTALE  
STRAIGHT ARM  
APPENDERIA FRONTALE  
**3019/0..**

Fe	∅4547	∅20 30 cm	€/u
----	-------	-----------	-----

--	--	--	--



**PERROQUET INCLINADO**  
PENDERIE FRONTALE  
SLOPING ARM  
APPENDERIA INCL.  
8 pins  
**3022/0..**

Fe	∅4547	∅16 30 cm	€/u
----	-------	-----------	-----

--	--	--	--



**GANCHO**  
CROCHET  
HOOK  
BARETTA  
**3014/0.. 25 cm**  
**3020/0.. 20 cm**  
**3021/0.. 10 cm**

Fe	∅4547	∅6	€/u
----	-------	----	-----

--	--	--	--



**GANCHO PORTAPRECIO**  
CROCHET PORTAPRIX  
HOOK LABEL-HOLDER  
BARETTA PORTAPREZZO  
**3012/0.. 25 cm**

Fe	∅4547	∅6 25 cm	€/u
----	-------	----------	-----

--	--	--	--



**PORTAPRECIO**  
PORTAPRIX  
LABEL HOLDER  
PORTAPREZZO  
**382/009**

plas	∅3012	50x50	€/u
------	-------	-------	-----

--	--	--	--



**SISTEMA SEGURIDAD**  
GANCHO SENCILLOS  
BLOCCAGE  
SECURITY LOCK  
BLOCCO SICUREZZA  
**373/00N**

plas	∅ max. ∅6		€/u
------	-----------	--	-----

--	--	--	--



**SISTEMA SEGURIDAD**  
GANCHOS DOBLES  
BLOCCAGE  
SECURITY LOCK  
BLOCCO SICUREZZA  
**383/00N**

plas	∅ max. ∅6		€/u
------	-----------	--	-----

--	--	--	--



**IMÁN ESPECIAL PARA SISTEMA SEGURIDAD**  
GANCHOS  
IMAN DESBLOCCAGE  
UNLOCK MAGNET  
MAGNETE SBLOCCO  
**384/000**

plas	∅ max. ∅6		€/u
------	-----------	--	-----

--	--	--	--



# VERTICAL

## GÓNDOLAS

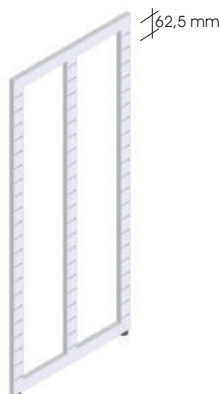

**MONTANTE CREMALL. 2 CARAS**  
**CRÉMAILLÈRE 2 CÔTES**  
**2 SIDES GONDOLA UPRIGHT**  
**MONTANTE CREMALLERA 2 LATI**  
 Niveladores suelo  
 Niveleurs au sol  
 Floor levellers  
 Livellatori suolo  
**2641/0..**

	BLANCO BLANC WHITE BIANCO	NEGRO NOIR BLACK NERO	COLOR COULEUR COLOR COLORE
	OB	ON	OP
Fe	1400x600x20		€/u
		o	o

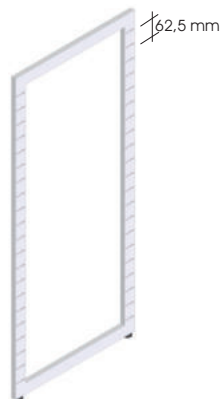

**MONTANTE CREMALL. 2 CARAS**  
**CRÉMAILLÈRE 2 CÔTES**  
**2 SIDES GONDOLA UPRIGHT**  
**MONTANTE CREMALLERA 2 LATI**  
 Niveladores suelo  
 Niveleurs au sol  
 Floor levellers  
 Livellatori suolo  
**2644/0..**

	BLANCO BLANC WHITE BIANCO	NEGRO NOIR BLACK NERO	COLOR COULEUR COLOR COLORE
	OB	ON	OP
Fe	1400x600x20		€/u
		o	o



**MONTANTE CREMALL. 2 CARAS**  
**CRÉMAILLÈRE 2 CÔTES**  
**2 SIDES GONDOLA UPRIGHT**  
**MONTANTE CREMALLERA 2 LATI**  
 Niveladores suelo  
 Niveleurs au sol  
 Floor levellers  
 Livellatori suolo  
**2642/0..**

	BLANCO BLANC WHITE BIANCO	NEGRO NOIR BLACK NERO	COLOR COULEUR COLOR COLORE
	OB	ON	OP
Fe	1400x50x20		€/u
		o	o



**CREMALL. 2 CARAS + BASE**  
**CRÉMAILLÈRE 2 CÔTES + BASE**  
**2 SIDES UPRIGHT + BASE**  
**CREMALLERA 2 LATI + BASE**  
 Base 380x380 mm  
 Base 380x380 mm  
**2648/0..**

	BLANCO BLANC WHITE BIANCO	NEGRO NOIR BLACK NERO	COLOR COULEUR COLOR COLORE
	OB	ON	OP
Fe	1400x50x20		€/u
		o	o

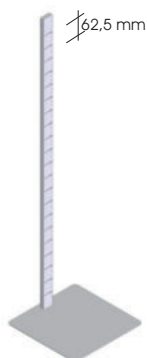

**CREMALL. 1 CARA + BASE**  
**CRÉMAILLÈRE 1 CÔTES + BASE**  
**1 SIDE UPRIGHT + BASE**  
**CREMALLERA 1 LATO + BASE**  
 Base 380x380 mm  
 Base 380x380 mm  
**2649/0..**

	BLANCO BLANC WHITE BIANCO	NEGRO NOIR BLACK NERO	COLOR COULEUR COLOR COLORE
	OB	ON	OP
Fe	1400x50x20		€/u
		o	o

# VERTICAL



**TIRANTE GÓNDOLA**  
**TIRANT ESPACEMENT**  
**ROD-SPACER**  
**TIRANTE DISTANZIATORE**  
**2643/1..** 120 cm

	CR. BRILLO CH-R. POLI BR. CHR CR. ILLC.	CR. MATE CH-R. M M. CHR CR. OPAC	BLANCO WHITE BIANCO	NEGRO BLACK NERO	COLOR COULEUR COLOR COLORE
	32	31	OB	ON	OP
Fe			50x20		€/u
				o	o

## ACCESORIOS GÓNDOLAS

ACCESSOIRES GONDOLA - GONDOLA ACCESSORIES - ACCESSORI GONDOLA



**SOPORTE CENTRAL**  
**support central**  
**central support**  
**supporto centrale**  
**2645/0..**

	Fe	∞4547	base 40 cm	€/u
				o



**SOPORTE ESTANTE**  
**MADERA**  
**SUPPORT TABLETTE BOIX**  
**WOOD SHELF BRACKET**  
**SUPP. RIPIANO LEGNO**  
**2646/0..**

	Fe	base 20 mm	€/u
			o



**SOPORTE PENDERIE**  
**A.TIRANTE**  
**SUPPORT TUBE PENDERIE**  
**AU TIRANT ESPACEMENT**  
**TUBE SUPPORT**  
**TO ROD-SPACER**  
**SUPPORTO TUBO A**  
**TIRANTE DISTANZIATORE**  
**2647/0..**

	Fe	2643∞4547	€/u
			o

## ACCESORIOS COMUNES MULTILAMAS

ACCESSOIRES MULTILAMAS - MULTILAMAS ACCESSORIES - ACCESSORI MULTILAMAS

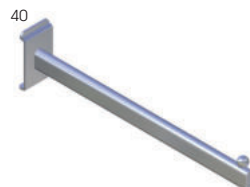

**PERROQUET PLANO**  
**PENDERIE FRONTALE**  
**STRAIGHT ARM**  
**APPENDERIA FRONTALE**  
**343/0..**

	Fe	base 40 mm	∅25x12,5 30 cm	€/u
				o



**PERROQUET INCLINADO**  
**PERROQUET INCLINÉ**  
**SLOPING ARM**  
**APPENDERIA INCL.**  
 10 pins  
**342/0..**

	Fe	base 40 mm	∅25x12,5 30 cm	€/u
				o

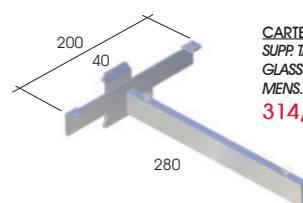

**CARTELA VIDRIO**  
**SUPP. TABLETTE VERRE**  
**GLASS SHELF BRACKET**  
**MENS. RIPIANO VETRO**  
**314/0..**

	Fe	base 40 mm	8-10 mm	€/u
				o



**SOPORTE CALZADO**  
**SOUTIEN CHAUSSANT**  
**FOOTWEAR SUPPORT**  
**SUPPORTO CALZATURE**  
**315/0..**

	Fe	250x100 mm	€/u
			o



## INSTAL - ÍNDEX

### OTROS SISTEMAS Y COMPLEMENTOS

<b>1- STAR 25</b>	<b>127</b>
Casquillos con accesorios Ø25 mm	
<b>2- STAR 8</b>	<b>129</b>
Casquillos con accesorios Ø8mm	
<b>3- CABLE DECO</b>	<b>130</b>
Accesorios deslizantes con cable 1,5mm - Para estanterías de vidrio/madera	
<b>4- ÓPTICA</b>	<b>131</b>
Expositores con o sin sistema de seguridad antirobo	
<b>5- JS - 25</b>	<b>133</b>
Sistema de nudos para tubo Ø25	
<b>6- STENDERS</b>	<b>135</b>
Soportes de confección móviles	

# STAR 25

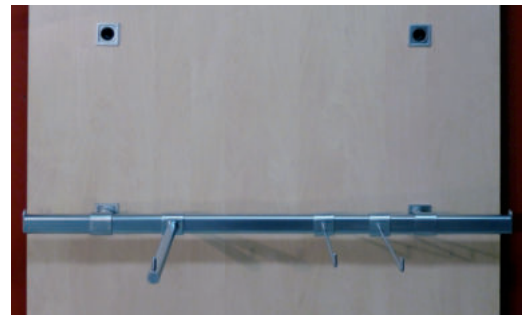
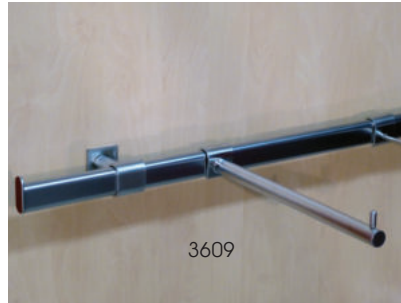

## STAR 25

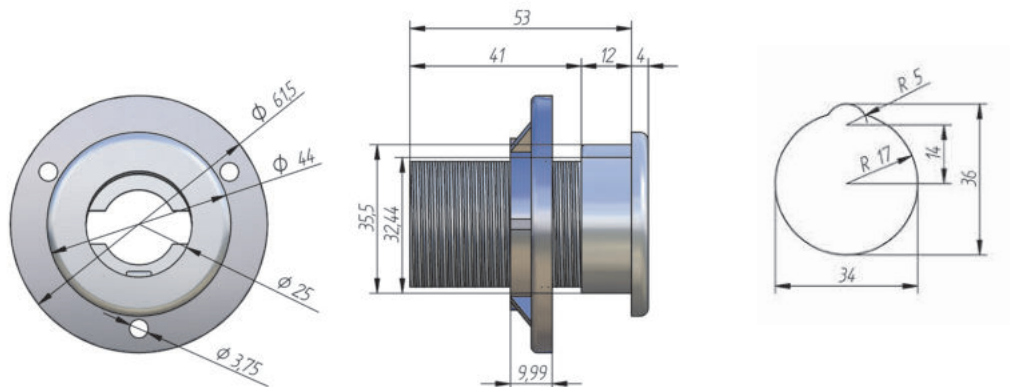

# STAR 25

CR. MATE  
CHR. M  
M. CHR.  
CR. OPAC  
**31**

Zn	1x Ø 34 - 1x Ø 10	13-30 mm	12 kg/u	€/u
----	-------------------	----------	---------	-----

**CASQUILLO REDONDO Ø44**  
Accessories Ø 25 mm  
INSERT ROND Ø44  
Accessoires Ø25mm  
ROUND SOCKET Ø44  
Fittings Ø25 mm  
BOCCOLA ROTONDA Ø44  
Accessori Ø25 mm  
**3602/031**



Fe	Ø25	330 mm	€/u
----	-----	--------	-----

**CARTELA**  
SUPPORT  
BRACKET  
MENSOLA  
**3620/031**



Fe	Ø25	250 mm	€/u
----	-----	--------	-----

**PERROQUET PLANO**  
PENDERIE FRONTAL  
STRAIGHT ARM  
APPENDERIA FRONTALE  
**3615/031** 250 cm  
**3614/031** 350 cm



Fe	Ø25	390 mm	€/u
----	-----	--------	-----

**PERROQUET INCLINADO**  
PENDERIE INCLINÉE  
SLOPING ARM  
APPENDERIA INCLINADA  
**3617/031**



Fe	Ø25	350 mm	€/u
----	-----	--------	-----

**PERROQUET PLANO "Z"**  
PENDERIE FRONTAL "Z"  
STRAIGHT ARM "Z"  
APPENDERIA FRONTALE "Z"  
**3616/031**

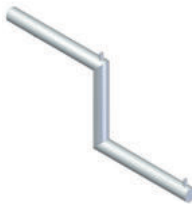

Fe	Ø25	320 mm	€/u
----	-----	--------	-----

**CARTELA BARRA PENDERIE**  
SUPPORT BARRE PENDERIE  
BRACKET HANGING BAR  
MENSOLA APPENDERIA  
**3618/031**

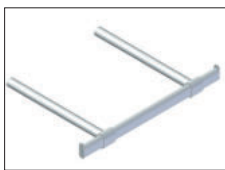

Fe	Ø25	330 mm	€/u
----	-----	--------	-----

**CARTELA BARRA PENDERIE**  
SUPPORT BARRE PENDERIE  
BRACKET HANGING BAR  
MENSOLA APPENDERIA  
**3619/031**

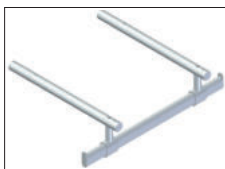

# STAR 25

CR. MATE  
CHR. M  
M. CHR.  
CR. OPAC  
**31**

Fe	Ø25	330 mm	€/u
∞ 4547(36x18)			

**CARTELA BARRA ACCESORIOS**  
SUPPORT BARRE ACCESSOIRES  
BRACKET FOR ACCESSORIES ROD  
MENSOLA TUBO PORTA-ACCESSORI  
**\*3609/031**



## TUBO OVALADO 36X18



Fe	1 m	36x18x1,5	€/m
----	-----	-----------	-----

**TUBO OVAL 36x18 mm**  
TUBE OVALE 36X18 mm  
OVAL TUBE 36X18 mm  
TUBO OVALE 36X18 mm  
**4547/10P**

Zn	46x18	∞ 4547	€/u
----	-------	--------	-----

**TAPA FINAL CON TOPE**  
EMBOUT AVEC RÉTENTION  
END-CAP WITH STOP  
COPRITESTA + RETENZIONE  
**\*4722/031**

## ACCESORIOS TUBO OVALADO 36X18



**PERROQUET PLANO**  
PENDERIE FRONTAL  
STRAIGHT ARM  
APPENDERIA FRONTALE  
**3019/0..**

Fe	∞ 4547	300 mm	€/u
----	--------	--------	-----



**GANCHO**  
CROCHET  
HOOK  
BARRETTA  
**3014/0..** 25 cm

Fe	∞ 4547	250 mm	€/u
----	--------	--------	-----



**GANCHO PORTAPRECIO**  
CROCHET PORTAPRIX  
HOOK LABEL-HOLDER  
BARRETTA PORTAPREZZO  
**3012/0..** 25 cm

Fe	∞ 4547	250 mm	€/u
----	--------	--------	-----



**PORTAPRECIO**  
PORTAPRIX  
LABELHOLDER  
PORTAPREZZO  
**382/009**

plas	40x50 mm	€/u
------	----------	-----



**BLOQUEO GANCHO**  
BLOPAGE BROCHE  
HOOK SECURITY LOCK  
BLOCCO SICUREZZA GANCHO  
**373/00N**

plas	Ø6 mm	€/u
------	-------	-----



**BLOQUEO GANCHO DOBLE**  
BLOPAGE BROCHE DOUBLE  
DOUBLE HOOK SECURITY LOCK  
BLOCCO GANCIO DOPPIO  
**383/00N**

plas	Ø6 mm	€/u
------	-------	-----



**IMÁN ESPECIAL DESBLOQUEO**  
UNLOCK MAGNET  
UNLOCK MAGNET  
MAGNETE DI SBLOCCO  
**384/000**

plas	373-383/00N	€/u
------	-------------	-----



# STAR 8

NUEVOS ACCESORIOS  
Y NUEVO SISTEMA ANTIGIRO

CR. MATE  
CHR. M  
M. CHR  
CR. OPAC  
**31**

Zn	1x Ø 8 - 1x Ø 4	8-22 mm	12 kg/u	€/u
----	-----------------	---------	---------	-----

**CASQUILLO REDONDO Ø22**  
Accesorios Ø 8 mm  
INSERT ROND Ø22  
Accessoires Ø8mm  
ROUND SOCKET Ø22  
Fittings Ø8 mm  
BOCCOLA ROTONDA Ø22  
Accessori Ø8 mm  
**3604/N31**



Fe	Ø 8 mm	€/u
----	--------	-----

**GANCHO**  
HOOK  
BROCHE  
BARRETTA  
**3605/N31** 15 cm  
**3606/N31** 20 cm  
**3607/N31** 25 cm



Fe	Ø 8 mm	€/u
----	--------	-----

**CARTELA**  
SUPPORT  
BRACKET  
MENSOLA  
**3627/N31** 15 cm  
**3628/N31** 25 cm



Fe	Ø 8 mm	€/u
----	--------	-----

**PERROQUET**  
PERROQUET  
ARM  
APPENDERIA  
**3624/N31** 30 cm



Fe	Ø 8 mm	€/u
----	--------	-----

**PERROQUET INCLINADO**  
PERROQUET INCLINÉE  
SLOPING ARM  
APPENDERIA INCLINADA  
**3625/N31**

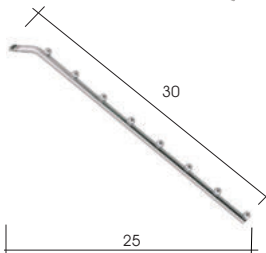

Fe	Ø 8 mm	€/u
----	--------	-----

**PERROQUET "Z"**  
PERROQUET "Z"  
ARM "Z"  
APPENDERIA "Z"  
**3629/N31**

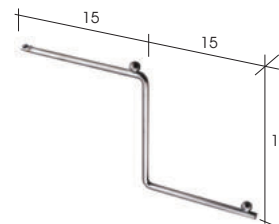

Fe	Ø 8 mm	€/u
----	--------	-----

**SOPORTE ZAPATO**  
SUPPORT CHAUSSURE  
SHOE SHELF  
SUPPORTO SCARPA  
**3623/N31**

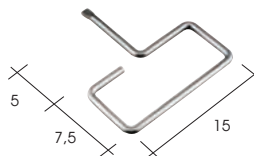

Fe	Ø 8 mm	€/u
----	--------	-----

**SOPORTE ZAPATO**  
SUPPORT CHAUSSURE  
SHOE SHELF  
SUPPORTO SCARPA  
**3630/N31**

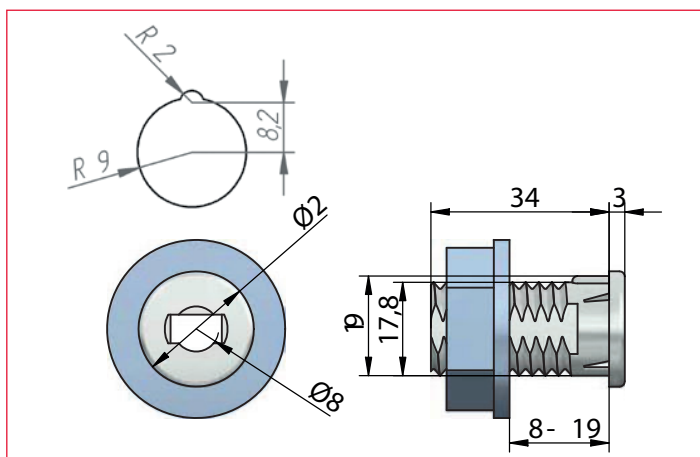
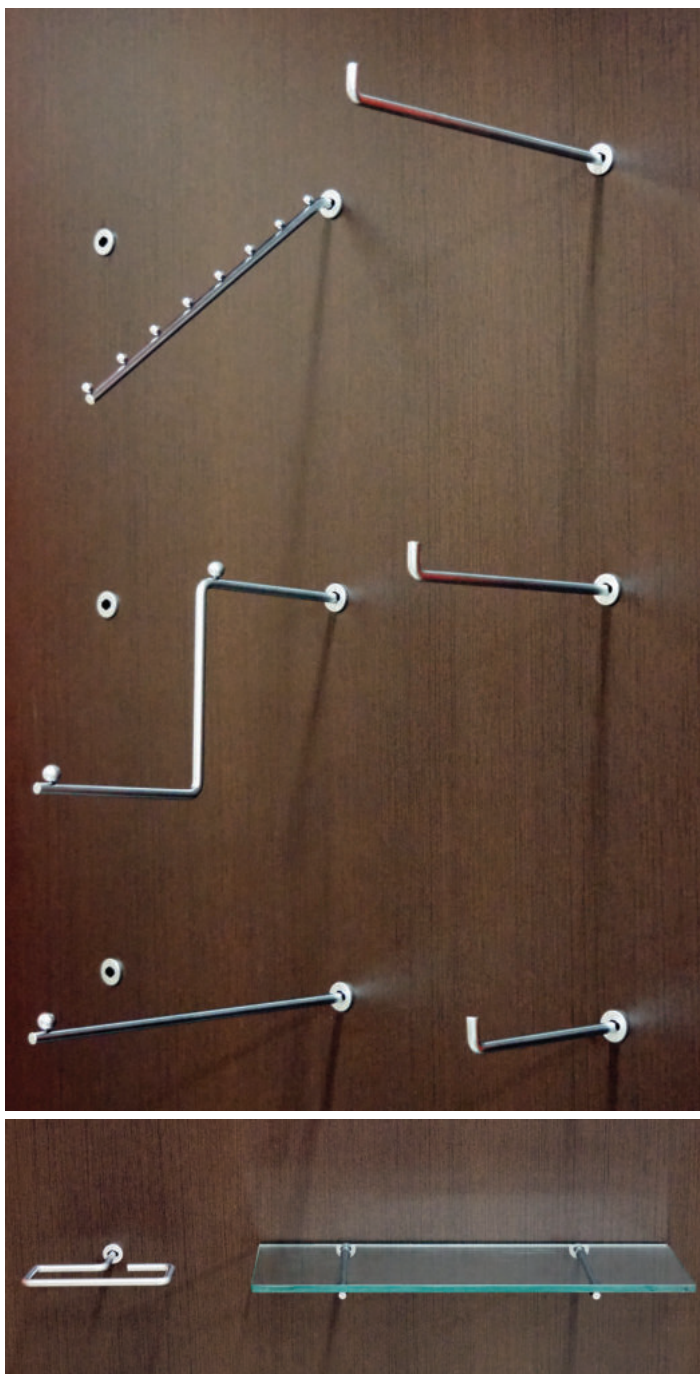
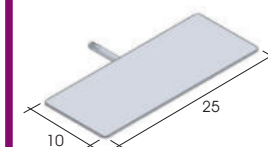

**! NUEVO**

# CABLE DECO

CR. BRILLO  
CHR. POLI  
BR. CHR  
CR. LUC.  
**32**



ENGANCHE TECHO  
ATELAGE PLAFOND  
CEILING CONNECTION  
AGGANCIO SOFFITTO  
**3410/032**

Cu	40kg/u		€/u
----	--------	--	-----



ROLLO  
50 METROS

CABLE INOX  
INOX WIRE  
Length: cut to size  
CÂBLE INOX  
longueur: coupé à la taille  
CAVO INOX  
Lunghessa: tagliato a misura  
**3411/128** VENTA POR METRO  
**3411/028** VENTA ROLLO 50 M

inox s.s.	40kg/u	Ø1,5mm	€/m
--------------	--------	--------	-----



ENGANCHE SUELO CON TENSOR  
ATELAGE PAVEMENT  
FLOOR CONNECTION  
AGGANCIO PAVIMENTO CON TENSOR  
**3412/032**

Cu			€/u
----	--	--	-----



ENGANCHE REGULABLE SUELO 180°  
ATELAGE RÉGLABLE 180° PAVEMENT  
ADJUSTABLE 180° FLOOR CONNECTION  
AGGANCIO REGOLABILE 180° PAVIMENTO  
**3425/032**

Cu			€/u
----	--	--	-----

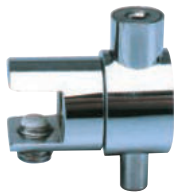

PINZA MÓVIL SENCILLA  
PINCE SIMPLES MOBILE  
SINGLE MOVABLE CLAMP  
MORSETTO MOBILE SEMPLICE  
**3415/032**

Cu	4-8 mm		€/u
----	--------	--	-----



PINZA MÓVIL DOBLE  
PINCE DOUBLE MOBILE  
DOUBLE MOVABLE CLAMP  
MORSETTO MOBILE DOPPIA  
**3416/032**

Cu	4-8 mm		€/u
----	--------	--	-----



SOPORTE ESTANTE VIDRIO  
CON TALADRO Ø14 MM  
GLASS SHELF SUPPORT WITH DRILL Ø14 mm  
SUPPORT DE TABLETTE AVEC TROU Ø14 mm  
SUPPORTO RIPIANO CON FORO Ø14 mm  
**3417/032**

Cu	Ø 14 mm	4-8 mm	€/u
----	---------	--------	-----

# CABLE DECO

CR. BRILLO  
CHR. POLI  
BR. CHR  
CR. LUC.  
**32**



SOPORTE ESTANTE MADERA CON TALADRO  
SUPPORT DE TABLETTE AVEC TROU  
GLASS SHELF SUPPORT WITH DRILL  
SUPPORTO RIPIANO CON FORO  
**3418/032**

Cu	Ø 2 mm		€/u
----	--------	--	-----



COLGADOR CUADROS  
HANGER PICTURES  
ANCRER POUR ACCROCHER TABLEAUX  
AGGANCIO PER APPENDERE QUADRI  
**3419/032**

Cu			€/u
----	--	--	-----

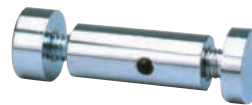

SOPORTE CUADRO CON TALADRO  
FRAME SUPPORT WITH DRILL  
SUPPORT TABLEAU AVEC TROU  
SUPPORTO PER QUADRO CON FORO  
**3420/032**

Cu	Ø 6 mm		€/u
----	--------	--	-----



ANCLAJE PESTAÑA ESTANTE INCLINADO  
SUPPORT ONGLET TABLETTE INCLINÉE  
TAB ANCHOR FOR INCLINED SHELF  
ANCORAGGIO BORDO RIPIANO INCLINATO  
**\*3421/032**

Cu	Ø 6 mm		€/u
----	--------	--	-----

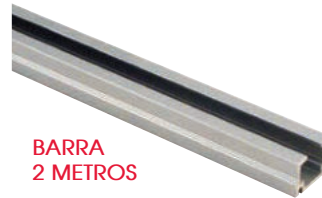

BARRA  
2 METROS

CARRIL PARA COLGAR A TECHO O A PARED.  
PROFIL POUR ACCROCHER AU PLAFOND OU AU MUR  
TRACK TO HANG ON THE CEILING OR WALL  
PROFILO DA APPENDERE A SOFFITTO O PARETE  
**3422/101**

Al	∞ 3427-3423-3424		€/m
----	------------------	--	-----



ENGANCHE CABLE A CARRIL 3422  
CÂBLE ATELAGE A LE PROFIL 3422  
WIRE/TRACK 3422 JOINT  
AGGANCIO CAVO AL PROFILO 3422  
**\*3427/032**

Cu	∞ 3422		€/u
----	--------	--	-----



ANCLAJE PARA COLGAR CUADROS A TECHO O PARED  
ANCRER POUR ACCROCHER TABLEAUX AU PLAFOND OU AU MUR  
HOOK FOR HANGING PICTURES ON THE WALL OR CEILING  
AGGANCIO PER APPENDERE QUADRI ALLA PARETE O AL SOFFITTO  
**3423/032**

Cu	∞ 3422		€/u
----	--------	--	-----



ANCLAJE PARA COLGAR CUADROS A TECHO, PARED Y COLUMNAS KADI  
ANCRER POUR ACCROCHER TABLEAUX AU PLAFOND, AU MUR OU COLUMNS KADI  
HOOK FOR HANGING PICTURES ON THE WALL, CEILING OR KADI COLUMNS  
AGGANCIO PER APPENDERE QUADRI ALLA PARETE, AL SOFFITTO O COLONNE KADI  
**3424/032**

Cu	∞ 3422		€/u
----	--------	--	-----

# ÓPTICA

## EXPOSITORES PARA GAFAS

Con ó sin cerradura (misma llave)  
Ganchos de acero

PRÉSENTOIRS POUR LUNETTES  
Avec ou sans serrure (même combinaison)  
Crochets en acier inoxydable

DISPLAYS FOR GLASSES  
With or without lock (keyed alike)  
Wire in stainless steel

DISPLAYS PER OCCHIALI  
Con o senza serratura (stessa combinazione)  
Ganci in acciaio inox

# ÓPTICA

PL. MATE  
ALU. MAT  
ALU. MATT  
ALL. NATURALE

01

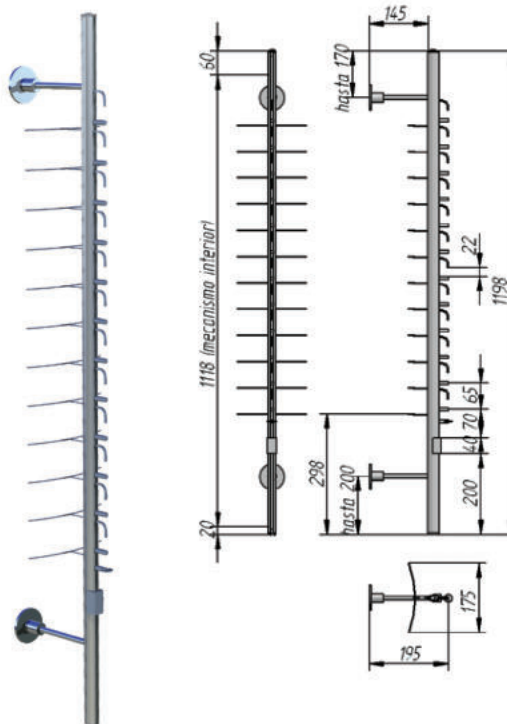

**BARRA PARED CON CERRADURA 120 cm**  
12 gafas - distancia gafas 70 mm

Al	Inox s.s.	120 cm	€/u
----	-----------	--------	-----

PRÉSENTOIR MURAL AVEC SERRURE 120 cm  
12 Lunettes - Distance lunettes: 65 mm  
WALL DISPLAY WITH LOCK 120 cm  
12 glasses - Distance glasses: 65 mm

DISPLAY PARETE CON SERRATURA 120 cm  
12 occhiali - Distanza occhiali: 65 mm

2595/001

PORTARÓTULO NO INCLUIDOS  
support-étiquettes non inclus  
brand holder not included  
supporto logo non inclusi

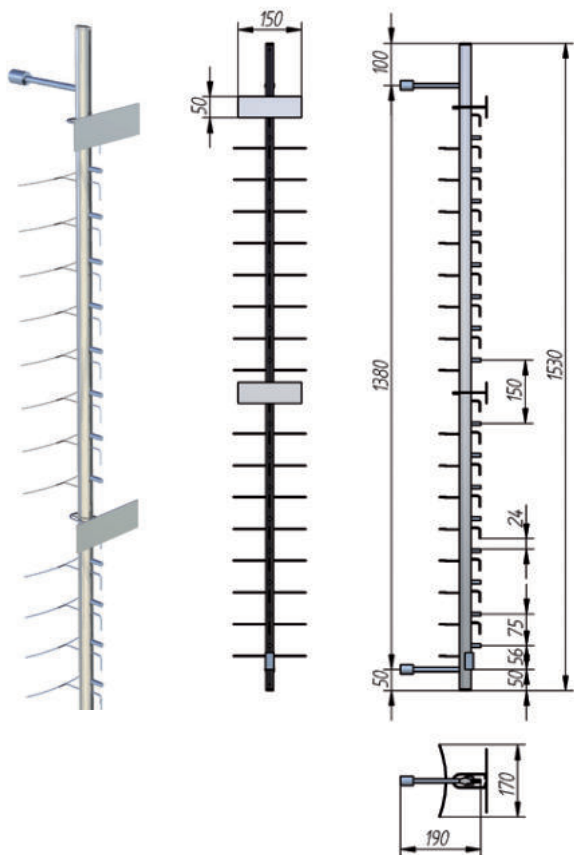

**BARRA PARED 8+8 CON CERRADURA**  
16 gafas - distancia gafas 75 mm

Al	Inox s.s.	153 cm	€/u
----	-----------	--------	-----

PRÉSENTOIR MURAL 8+8 AVEC SERRURE  
16 lunettes - Distance lunettes: 75 mm  
WALL DISPLAY 8+8 WITH LOCK

16 glasses - Distance glasses: 75 mm  
DISPLAY PARETE 8+8 CON SERRATURA  
16 occhiali - Distanza occhiali: 75 mm

2585/001

2 PORTARÓTULOS INCLUIDOS  
2 support-étiquettes inclus  
2 brand holders included  
2 supporti logo inclusi

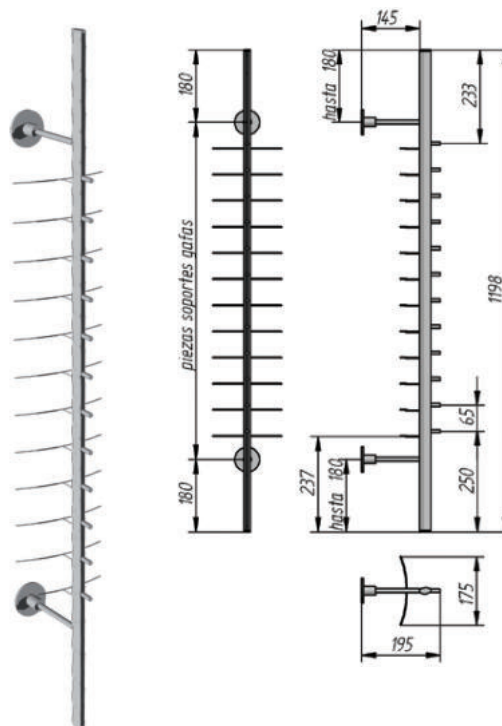

**BARRA PARED SIN CERRADURA 120 cm**  
12 gafas - distancia gafas 65 mm

Al	Inox s.s.	120 cm	€/u
----	-----------	--------	-----

PRÉSENTOIR MURAL SIN SERRURE 120 cm  
12 Lunettes - Distance lunettes: 65 mm  
WALL DISPLAY WITHOUT LOCK 120 cm  
12 glasses - Distance glasses: 65 mm

DISPLAY PARETE SENZA SERRATURA 120 cm  
12 occhiali - Distanza occhiali: 65 mm

2591/001

PORTARÓTULO NO INCLUIDOS  
support-étiquettes non inclus  
brand holder not included  
supporto logo non inclusi



## ÓPTICA

PL. MATE  
ALU. MAT  
ALU. MATT  
ALL. NATURALE  
**01**

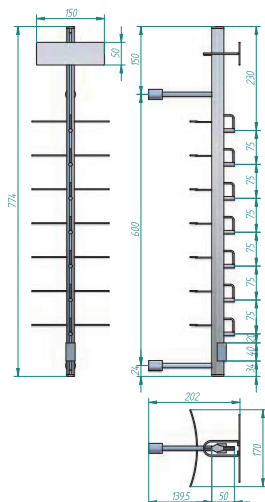

**BARRA PARED CON CERRADURA 77,4 cm**  
7 gafas - distancia gafas 75 mm  
**PRÉSENTOIR MURAL AVEC SERRURE 77,4 cm**  
7 lunettes - Distance lunettes: 75 mm  
**WALL DISPLAY WITH LOCK 77,4 cm**  
7 glasses - Distance glasses: 75 mm  
**DISPLAY PARETE CON SERRATURA 77,4 cm**  
7 occhiali - Distanza occhiali: 75 mm  
**\*2597/001**

PORTARÓTULO NO INCLUIDOS  
support-étiquettes non inclus  
brand holder not included  
supporto logo non inclusi



**PORTARÓTULO**  
pintado en gris  
**SUPPORTÉTIQUETTE**  
peint en gris  
**BRAND HOLDER**  
painted gray  
**SUPPORTO LOGO**  
verniciato grigio  
**2584/00M**

Fe	150x50 mm
∞	2591-2594-2595-2597

## ÓPTICA

PL. MATE  
ALU. MAT  
ALU. MATT  
ALL. NATURALE  
**01**

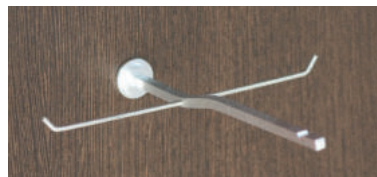

**SOPORTE GAFAS PANEL**  
Se fija por detrás o delante  
**SUPPORT LUNETTES AU PANNEAU**  
Fixé de derrière le panneau  
**GLASSES SUPPORT TO PANEL**  
Fixed from behind the panel  
**SUPPORTO OCCHIALI A PANNELLO**  
Fissato da dietro  
**2593/001**

Al	172x170 mm	€/u
----	------------	-----



**SOPORTE GAFAS PANEL**  
Se fija por delante  
**SUPPORT LUNETTES AU PANNEAU**  
Fixé devant le panneau  
**GLASSES SUPPORT TO PANEL**  
Fixed in front of the panel  
**SUPPORTO OCCHIALI A PANNELLO**  
Fissato da davanti  
**2592/032**

Al	180x190 mm	€/u
----	------------	-----

CR. BRILLO  
CH. POLI  
BR. CH.  
CR. ILLUC.  
**32**

## OPTI-3

PL. M	COLOR	BLANCO	NEGRO	CR. BRILLO
ALU. M	COULEUR	BLANC	NOIR	CH. POLI
ALU. M	COLOR	WHITE	BLACK	BR. CH.
ALL. NAT	COLORE	BIANCO	NERO	CR. ILLUC.
<b>01</b>	<b>OP</b>	<b>OB</b>	<b>ON</b>	<b>32</b>

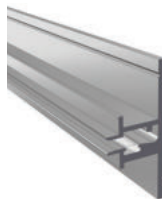

**PERFIL INVISIBLE PARA ESTANTES**  
DE 3 MM DE ESPESOR  
**PROFIL INVISIBLE POUR ÉTAGÈRES**  
3 MM D'ÉPAISSEUR  
**INVISIBLE PROFILE FOR SHELVES**  
3 MM THICK  
**PROFILO INVISIBILE PER RIPIANI DI**  
3 MM DI SPESSORE  
**360/1..**

Al	5 m	6/8 mm	€/m
----	-----	--------	-----



**ESTANTE PLEGADO 3 MM**  
**SUPPORT-TABLETTE 3MM**  
**FOLDED BRACKET-SHELF 3 MM**  
**MENSOLA-RIPIANO PIEDATA 3 MM**  
**387/0..**

Fe	190x190x50 mm	€/u
----	---------------	-----



**ESTANTE 3 MM**  
**SUPPORT-TABLETTE 3MM**  
**BRACKET-SHELF 3 MM**  
**MENSOLA-RIPIANO 3 MM**  
**388/0..**

Fe	190x190 mm	€/u
----	------------	-----

## PARALELO 384

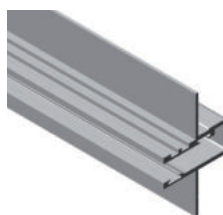

**PERFIL INVISIBLE**  
**PROFIL D'ALUMINIUM**  
**ALUMINIUM PROFILE**  
**PROFILO DI ALLUMINIO**  
**384/1..**

Al	5 m	5/6/8 mm	€/m
∞	384/1181		



**GOMA DURA**  
**CAOUTCHOUC DUR**  
**HARD RUBBER**  
**GOMMA DURA**  
**384/109**

plac	∞ 384	€/m
------	-------	-----



**GANCHO GAFAS**  
**SUPPORT POUR LUNETTES**  
**SUPPORT FOR GLASSES**  
**BARRETTA PER OCCHIALI**  
**\*379/0..**

Fe		€/u
----	--	-----

# JS 25



**JS-25**

**NUDOS**



**NUDO 3 SALIDAS**  
JOINT À 3 VOIES  
3 WAY JOINT  
GIUNTO 3 VIE  
**150/0..**



**NUDO 4 SALIDAS**  
JOINT À 4 VOIES  
4 WAY JOINT  
GIUNTO 4 VIE  
**151/0..**



**NUDO 4 SALIDAS EN CRUZ**  
JOINT À 4 VOIES A CROIX  
4 WAY CROSS-JOINT  
GIUNTO 4 VIE A CROCE  
**152/0..**



**NUDO 5 SALIDAS**  
JOINT À 5 VOIES  
5 WAY JOINT  
GIUNTO 5 VIE  
**153/0..**



**NUDO PARALELO DOBLE**  
JOINT À 2 VOIES PARALLÈLES  
2 PARALLEL WAY JOINT  
GIUNTO 2 VIE PARALLELE  
**154/0..**



**NUDO PARALELO TRIPLE**  
JOINT À 3 VOIES PARALLÈLES  
3 PARALLEL WAY JOINT  
GIUNTO 3 VIE PARALLELE  
**155/0..**



**NUDO 6 SALIDAS**  
JOINT À 2 VOIES  
2 WAY JOINT  
GIUNTO 2 VIE  
**156/0..**



**NUDO ROTATIVO DOBLE**  
JOINT ROTATIVE DOUBLE  
DOUBLE ROTATIVE JOINT  
GIUNTO ROTANTE DOPPIO  
**\*157/0..**



**BRIDA ESPEJOS**  
BRIDE MIROIRS  
CLAMP MIRRORS  
GIUNTO PER SPECCHIO  
**\*159/0..**

**TUBOS Ø 25MM**



**TUBO Ø 25 mm**  
TUBE Ø 25 mm  
TUBE Ø 25 mm  
TUBO Ø 25 mm  
**203/3.. 300 cm**

**PROBADORES**

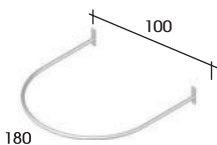

**PROBADOR ISLA**  
DRESSING ROOM  
CABINE D'ESSAYAGE  
CAMERINO PROVA  
**283/0..**

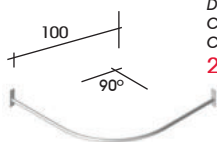

**PROBADOR RINCÓN**  
DRESSING ROOM  
CABINE D'ESSAYAGE  
CAMERINO PROVA  
**284/0..**

RAL 9006 = color OP metal. 0M= 032+50%					
CR. BRILLO	CR. ORO	CR. MATE	BLANCO	NEGRO	COLOR
CR. POLI	CR. DOR	CR. MI	BLANC	NOIR	COULEUR
BR. CHR	GOLD. C	MI. CHR	WHITE	BLACK	COLOR
CR. ILLC.	CR. ORO	CR. OPAC	BIANCO	NERO	COLORE
32	33	31	0B	0N	0P
Al	Ø25	∞ 203			€/u
			o	o	
Al	Ø25	∞ 203			€/u
			o	o	
Al	Ø25	∞ 203			€/u
			o	o	
Al	Ø25	∞ 203			€/u
			o	o	
Al	Ø25	∞ 203			€/u
			o	o	
Al	Ø25	∞ 203			€/u
			o	o	
Al	Ø25	∞ 203			€/u
			o	o	
Al	Ø25	∞ 203			€/u
			o	o	
Al	Ø25	∞ 203			€/u
			o	o	
Al	Ø25	∞ 203			€/u
			o	o	
Al	Ø25	∞ 203			€/u
			o	o	
Fe	3 m				€/u
			o	o	
Fe	100x100 cm				€/u
			o	o	
Fe	100x100 cm				€/u
			o	o	

**JS-25**

**ACCESORIOS**

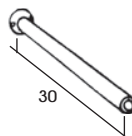

**SEPARADOR PARED**  
SÉPARATEUR MUR  
WALL SPACER  
DISTANZIALE  
**226/0..**



**BASE SUELO Y PARED**  
PLATINE FIXATION MUR  
WALL RING NUT  
GHIERA DI FISSAGGIO  
**225/0..**

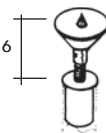

**NIVELADOR TECHO**  
VÉRIN SUPÉRIEURE (sol-plafond)  
UPPER LEVEL (floor-ceiling)  
LIVELLATORE SUPERIORE (suolo-soffitto)  
**228/0..**

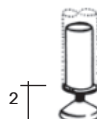

**NIVELADOR SUELO**  
VÉRIN INFÉRIEUR (sol-plafond)  
LOWER LEVEL (floor-ceiling)  
LIVELLATORE INFERIORE (suolo-soffitto)  
**229/0..**



**NIVELADOR M8**  
VÉRIN M8  
LEVELLER M8  
PIEDINO LIVELLATORE M8  
**231/00N**

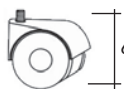

**RUEDA + CASQUILLO Ø25**  
ROUE + JOINT Ø25  
CASTOR + JOINT Ø25  
ROUTA + GIUNTO Ø25  
**232/01N**



**FINAL REMATE**  
EMBOUT Ø 25 mm  
END-CAP Ø 25 mm  
COPRITESTA Ø 25 mm  
**236/0..**

**CARTELAS**

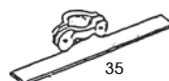

**CARTELA FINAL**  
SUPPORT FINAL  
FINAL BRACKET  
MENSOLA FINALE  
**163/0..**

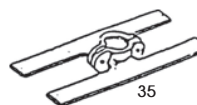

**CARTELA CENTRAL**  
SUPPORT CENTRAL  
CENTRAL BRACKET  
MENSOLA CENTRALE  
**165/0..**

CR. BRILLO	CR. ORO	CR. MATE	BLANCO	NEGRO	COLOR
CR. POLI	CR. DOR	CR. MI	BLANC	NOIR	COULEUR
BR. CHR	GOLD. C	MI. CHR	WHITE	BLACK	COLOR
CR. ILLC.	CR. ORO	CR. OPAC	BIANCO	NERO	COLORE
32	33	31	0B	0N	0P
Fe	300 mm Ø25				€/u
			o	o	
Fe	Ø25				€/u
			o	o	
Fe	Ø25				€/u
			o	o	
Fe	Ø25				€/u
			o	o	
plac	M8				€/u
			o	o	
plac	M8 Ø50	30kg/u			€/u
			o	o	
plac	Ø25				€/u
			o	NEGRO	
			o	o	
Fe	350 mm Ø25				€/u
			o	o	
Fe	350 mm Ø25				€/u
			o	o	



# STENDER

CR. BRILLO  
CHR. POLI  
BR. CHROME  
CR. LUCIDO  
**32**



**UNIVERSAL 1 m**  
altura regulable  
extensión lateral  
alto: 130/210 cm  
largo: 100/160 cm  
tubo de 28 mm  
rueda d.65 mm  
**PORTANT UNIVERSEL 100 cm**  
**UNIVERSAL FASHION RACK 100 cm**  
**STAENDER UNIVERSALE 100 cm**  
**26/032**

Fe	↔100/160 cm	↓130/210 cm	€/u
----	-------------	-------------	-----



**UNIVERSAL 1,4 m**  
altura regulable  
extensión lateral  
alto: 130/210  
largo:140/200  
tubo de 28 mm  
rueda D.50 mm  
**PORTANT UNIVERSEL 140 cm**  
**UNIVERSAL FASHION RACK 140 cm**  
**STAENDER UNIVERSALE 140 cm**  
**28/032**

Fe	↔140/200 cm	↓130/210 cm	€/u
----	-------------	-------------	-----



**UNIVERSAL DOBLE 1,4 m**  
altura regulable  
extensión lateral  
alto: 130/210  
largo: 140/200  
tubo de 28 mm  
**PORTANT DOUBLER UNIVERSEL 140 cm**  
**UNIVERSAL FASHION DOUBLE RACK 140 cm**  
**STAENDER DOPPIO UNIVERSALE 140 cm**  
**29/032**

Fe	↔140/200 cm	↓130/210 cm	€/u
----	-------------	-------------	-----



**PLEGABLE**  
altura regulable.  
extensión lateral.  
alto: 150/190.  
largo: 78/126.  
tubo de 22 mm.  
rueda d.80 mm  
**PORTANT PUIAGE 78 cm**  
**FOLDING FASHION RACK 78 cm**  
**STAENDER PIEGABLE 78 cm**  
**30/032**

Fe	↔78/126 cm	↓150/190 cm	€/u
----	------------	-------------	-----



**CIRCULAR**  
aro 80 cm.  
alto: 125/210.  
rueda D.50 mm  
**PORTANT RÉGLABLE AVEC ANNEAU**  
**ROUND-RING ADJUSTABLE RACK**  
**STAENDER CON ANELLO REGOLABILE**  
**\*34/032**

Fe	↔280 cm	↓125/210 cm	€/u
----	---------	-------------	-----

CR. BRILLO BLANCO NEGRO COLOR  
CHR. POLI BLANC NOIR COULEUR  
BR. CHR. WHITE BLACK COLOR  
CR. LUC. BIANCO NERO COLORE  
**32 OB ON OP**

# PROBADORES

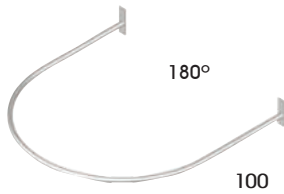

**PROBADOR ISLA**  
**CABINE D'ESSAYAGE**  
**DRESSING ROOM**  
**CAMERINO PROVA**  
**283/0..**

Fe	100x100 cm		€/u
----	------------	--	-----

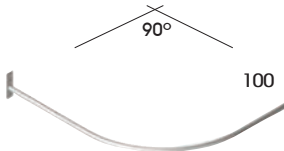

**PROBADOR RINCÓN**  
**CABINE D'ESSAYAGE**  
**DRESSING ROOM**  
**CAMERINO PROVA**  
**284/0..**

Fe	100x100 cm		€/u
----	------------	--	-----

# STENDER

CR. BRILLO BLANCO NEGRO COLOR  
CHR. POLI BLANC NOIR COULEUR  
BR. CHR. WHITE BLACK COLOR  
CR. LUC. BIANCO NERO COLORE  
**32 OB ON OP**



**\*BANDEJA:  
VENTA POR  
SEPARADO**



**25 Ø**



**STENDER PEQUEÑO**  
**STENDER PETIT**  
**STENDER SMALL**  
**STAENDER PICOLO**  
**31/0..**

Fe	40 kg	↔70 cm	↓150 cm	€/u
----	-------	--------	---------	-----



**STENDER MEDIANO**  
**STENDER MOYEN**  
**STENDER MEDIUM**  
**STAENDER MEDIO**  
**32/0..**

Fe	40 kg	↔100 cm	↓150 cm	€/u
----	-------	---------	---------	-----



**STENDER GRANDE**  
**STENDER GRAND**  
**STENDER LARGE**  
**STAENDER GRANDE**  
**33/0..**

Fe	40 kg	↔140 cm	↓150 cm	€/u
----	-------	---------	---------	-----



**BANDEJA**  
**STENDER GRAND**  
**STENDER LARGE**  
**STAENDER GRANDE**  
**38/0..**

Fe	15 kg	30x38x2,5 cm	€/u
----	-------	--------------	-----



**NUEVO**

# instal.



# Outlet

Instalación Comercial

## TARIFA 63

01/07/2023

# KADÍ - CARTELAS

ACCESORIOS - ACCESSOIRES  
FITTINGS - ACCESSORI

RAL 9006 = color OP metal. OM = 032+50%					
CR. BRILLO	INOX	SAT	CR. MATE	BLANCO	NEGRO
CHR. POLI	INOX	SAT	CHR. M	BLANC	NOIR
BR. CHR	S.S.S.		M. CHR	WHITE	BLACK
CR. LUC.	INOX	SAT	CR. OPAC	BLANCO	NERO
				COLOR	COULEUR
				COLOR	COLOR
				COLOR	COLOR
				0B	0N
				OP	

## CARTELAS "EMPOTRABLE" INOX+TUBO Ø25

inox 32 cm ∅ 4700-4701-203 (Ø25) €/u

**CARTELA + BARRA PENDERIE**  
SUPPORT + BARRE PENDERIE  
BRACKET + HANGING BAR  
MENSOLA + APPENDERIA

4677/028 derecha  
droite/right/destra  
4678/028 izquierda  
gauche/left/sinistra



inox s.s. 6 m ∅ 4677-4678 32 cm €/m

**TUBO Ø25**  
TUBE Ø25  
TUBE Ø25  
TUBO Ø25

203/128

plas Ø25 ∅ 203 €/u

inox s.s. Negro

**TAPA FINAL**  
EMBOUT  
END-CAP  
COPRITESTA

236/0..

## \*CARTELAS "TIBURÓN"

Fe ∅ 4700-4701 €/u

**CARTELA**  
SUPPORT  
BRACKET  
MENSOLA

\*4662/032 33 cm \*o

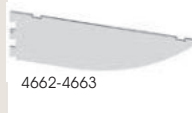

Fe 33 cm ∅ 4700-4701-4547 (36x18) €/u

**CARTELA + BARRA PENDERIE**  
SUPPORT + BARRE PENDERIE  
BRACKET + HANGING BAR  
MENSOLA + APPENDERIA

\*4665/0.. final \*o  
\*4666/0.. central \*o

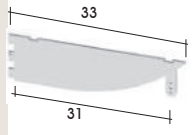

## CARTELA "TIBURÓN"

SUPPORTS "TIBURÓN"  
"TIBURÓN" BRACKETS SERIES  
MENSOLE "TIBURÓN"

estante vidrio = ventosas  
tablette en bois = ventouses  
wood shelf = suctions  
ripiano di legno = ventose



estante madera = tornillos  
tablette en bois = vis  
wood shelf = screws  
ripiano di legno = viti

# \*KADÍ - LOW COST

ILUMINACIÓN 230V - ECLAIRAGE 230V  
230V LIGHTING - ILLUMINAZIONE 230V

PLÁSTICO  
PLASTIQUE  
PLASTIC  
PLASTICA  
09

## CARRIL ELECTRIFICADO 230V-16V

RAIL ÉLECTRIFIÉ - ELECTRIFIED TRACK - BINARIO ELETRIFICATO

Al 1/2 m 32,5x16 230V-16A €/u

**CARRIL ELECTRIFICADO 230V**  
RAIL ÉLECTRIFIÉ 230V  
ELECTRIFIED TRACK 230V  
BINARIO ELETRIFICATO 230V

\*4774/101 1m \*o  
\*4775/201 2m \*o

plas 230V-2,5A €/u

**CONEXIÓN DESLIZANTE A CARRIL ELECTRIFICADO**  
LIAISON COULISSANTE A RAIL ÉLECTRIFIÉ 230V  
SLIDING CONNECTION TO ELECTRIFIED TRACK 230V  
CONNESSIONE SCORREVOLE A BINARIO ELETRIFICATO 230V

\*4776/009 \*o



## \*LAMAS - ACCESORIOS

ACCESORIOS ALUMINIO - ACCESSOIRES ALUMINIUM  
ALUMINIUM FITTINGS - ACCESSORI ALLUMINIO

BLANCO	NEGRO	COLOR	PL. M.
BLANC	NOIR	COULEUR	ALU. M.
BLAVCO	NERO	COLOR	ALL. NAT.
0B	0N	0P	0I

## ACCESORIOS DE ALUMINIO

Al 325 mm €/u

**PERROQUET PLANO**  
PENDERIE FRONTAL  
STRAIGHT ARM  
APPENDERIA FRONTALE

\*394/001 \*o

Al 315 mm €/u

**PERROQUET INCLINADO**  
PENDERIE INCLINÉE  
SLOPING ARM  
APPENDERIA INCLINADA

\*395/001 \*o



## \*PARALELO - LOW COST

### PERFIL PARALELO 391 EMPOTRABLE

- Admite estante de vidrio de 8 mm  
SE RECOMIENDA VIDRIO DE SEGURIDAD  
- empotrable en la madera.  
- Peso max. admitido: 20 kg/ml

LAMA aluminium INVISIBLE 391  
- Permet étagère en verre 8 mm d'épaisseur  
Verre de sécurité est recommandé  
- Profil intégré pour derrière en le bois.  
- Max. poids admis: 20kg / ml

LAMA aluminium INVISIBLE 391  
- Allows glass shelf 8 mm thick  
Safety glass is recommended  
- Profile fitted from behind.  
- Max. admitted weight 20 kg / ml

LAMA alluminio INVISIBLE 391  
- ammette ripiani in vetro 8 mm  
Si raccomanda l'uso di vetro securizzato  
- Profilo inserito da dietro nel legno.  
- Peso massimo ammesso: 20 kg/ml

Al 8 mm 20kg/ml €/m  
∅ 385, 386, 387, 388

\*391/1.. \*o



### PERFIL PARALELO MAXI 389

- Admite estante de vidrio de 8 mm  
SE RECOMIENDA VIDRIO DE SEGURIDAD  
- Sistema machihembrado  
- Peso max. admitido: 30 kg/ml  
- Admide iluminación LED

LAMA aluminium INVISIBLE 389  
- Permet étagère en verre 8 mm d'épaisseur  
Verre de sécurité est recommandé  
- montage panneau à emboîtement  
- Max. poids admis: 25 kg / ml  
- Permet l'éclairage LED

LAMA aluminium INVISIBLE 389  
- Allows glass shelf 8 mm thick  
Safety glass is recommended  
- Socket joint  
- Max. admitted weight 30 kg / ml  
- Allows LED lighting

LAMA alluminio INVISIBLE 389  
- ammette ripiani in vetro 8 mm  
Si raccomanda l'uso di vetro securizzato  
- Sistema incastrato  
- Peso massimo ammesso: 30 kg/ml  
- Ammette LEDs

Al 8 mm 30kg/ml €/m

\*389/1.. o



### PERFIL INVISIBLE PARED "MAXI"

LAMA ALUMINIO  
PROFIL D'ALUMINIUM  
ALUMINIUM PROFILE  
PROFILO DI ALLUMINIO

NO COMPATIBLE con acc.  
385, 386, 387, 388.

\*389/1.. o



# OPTICA - LOW COST

## EXPOSITOR PARA FONDO DE METACRILATO

PRÉSENTOIR POUR FOND MÉTHACRYLATE  
DISPLAY FOR PLEXIGLASS BACK  
DISPLAY PER FONDO IN PLEXIGLASS

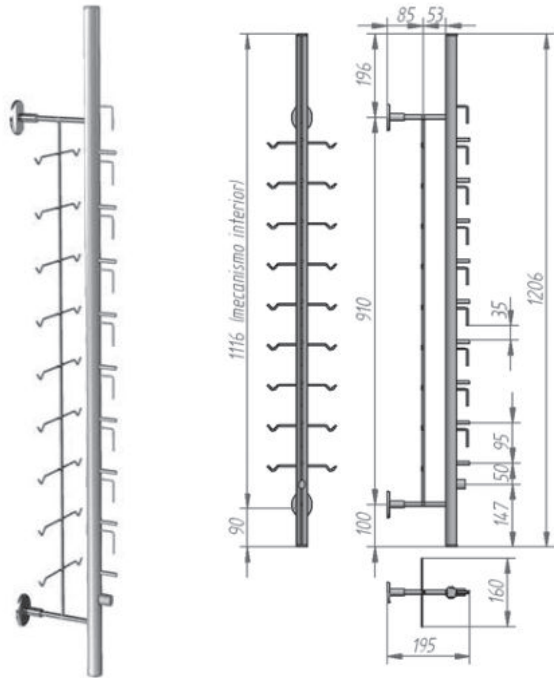

**BARRA "XL"**  
95 MM ENTRE LAS GAFAS  
95 MM ENTRE LUNETTES  
95 MM BETWEEN GLASSES  
95 MM FRA OCCHIALI

**BARRA "XL" PARED CON CERRADURA**  
2 gafas. Distancia gafas: 95 mm

Al	inox	120 cm	€/u
	s.s.		

**PRÉSENTOIR "XL" MURAL AVEC SERRURE 120 cm**  
9 lunettes - Distance lunettes: 95 mm

**WALL DISPLAY "XL" WITH LOCK 120 cm**  
9 glasses - Distance glasses: 95 mm

**DISPLAY PARETE "XL" CON SERRATURA 120 cm**  
9 occhiali - Distanza occhiali: 95 mm  
\*2587/001

\*o

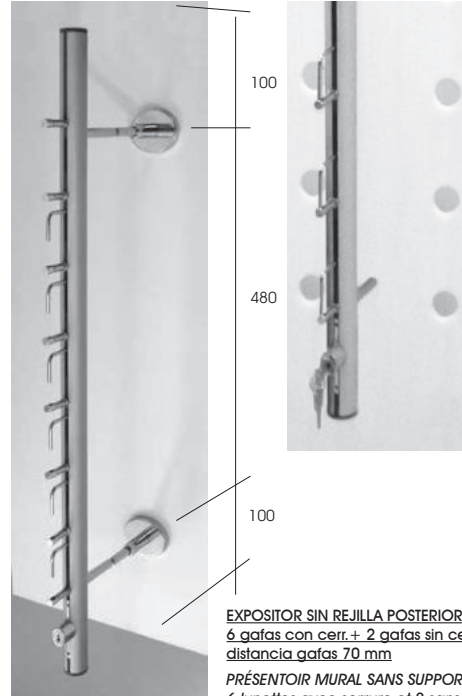

**EJEMPLO DE APLICACION CON PANEL RETROILUMINADO Y AGUJEREO PARA APOYAR LAS LAS GAFAS**  
EXEMPLE D'APPLICATION AVEC PANNEAU RÉTROÉCLAIRÉ ET TROUS POUR SOUTENIR LES LUNETTES  
APPLICATION EXAMPLE WITH BACKLITTED PANEL WITH HOLES WITH HOLES AS GLASSES SUPPORT  
ESEMPIO D'APPLICAZIONE CON PANNELLO RETROILLUMINATO E FORI COME SUPPORTO OCCHIALI

**EXPOSITOR SIN REJILLA POSTERIOR**  
6 gafas con cerr.+ 2 gafas sin cerr.  
distancia gafas 70 mm

Al	inox	68 cm	€/u
	s.s.		

**PRÉSENTOIR MURAL SANS SUPPORT DARRIÈRE**  
6 lunettes avec serrure et 2 sans -  
Distance lunettes: 70 mm

**WALL DISPLAY WOTHOUT BACK SUPPORT**  
6 glasses with lock and 2 without -  
Distance glasses: 70 mm

**DISPLAY PARETE SENZA SUPPORTO RETRO**  
6 occhiali con serratura e 2 senza -  
Distanza occhiali: 70 mm  
\*2586/000

\*o



Al	inox	78,5 cm	€/u
	s.s.		

**EXPOSITOR SOBRE-MESA**  
6 gafas - distancia gafas: 70 mm  
Altura total: 785 mm

**PRÉSENTOIR DE COMPTOIR**  
6 lunettes - Distance lunettes: 70 mm  
Hauteur totale: 785 mm  
Base: Ø 260 mm

**TABLE DISPLAY**  
6 glasses - Distance glasses: 70 mm  
Total height: 785 mm  
Base: Ø 260 mm

**DISPLAY TAVOLO**  
6 occhiali - distanza occhiali 80 mm  
Altezza totale: 785 mm  
Base: Ø 260 mm

\*2580/000

\*o



# \*MASTER 20X20

CR. BRILLO CHR. POLI BR. CHR CR. LUC.	NEGRO NOIR BLACK NERO	PLÁSTICO PLASTIC PLASTICA
32	0N	09
Zn	20x20mm	€/u
	o	
Zn	20x20mm M10	€/u
	o	
Zn	20x20mm	€/u
	o	
Zn	20x20mm M8	€/u
	o	
Zn	20x20mm	€/u
	o	
Zn	20x20mm	€/u
	o	
Zn	20x20mm	€/u
	o	
Zn	20x20mm	€/u
	o	
Zn	20x20mm	€/u
	o	
plas	M10	€/u
	o	
plas	M10 Ø50	30kg/u €/u
	o	

**NUDO 3 VIAS**  
JOINT À 3 VOIES  
3 WAY JOINT  
GIUNTO 3 VIE  
3800/0..

**NUDO 3 VIAS + ROSCAM10**  
JOINT À 3 VOIES + TROU M10  
3 WAY JOINT + M10 HOLE  
GIUNTO 3 VIE + FORO M10  
3801/0..

**NUDO 4 VIAS**  
JOINT À 4 VOIES  
4 WAY JOINT  
GIUNTO 4 VIE  
3802/0..

**NUDO 4 VIAS + ROSCAM10**  
JOINT À 4 VOIES + TROU M10  
4 WAY JOINT + M10 HOLE  
GIUNTO 4 VIE + FORO M10  
3803/0..

**NUDO 5 VIAS**  
JOINT À 5 VOIES  
5 WAY JOINT  
GIUNTO 5 VIE  
3804/0..

**NUDO 2 VIAS**  
JOINT À 2 VOIES  
2 WAY JOINT  
GIUNTO 2 VIE  
3805/0..

**NUDO 6 VIAS (EN BRUTO)**  
JOINT À 6 VOIES (EN BRUT)  
6 WAY JOINT (RAW MATERIAL)  
GIUNTO 6 VIE (IN GREZZO)  
3806/000

**NUDO 3 VIAS "T"**  
JOINT À 3 VOIES "T"  
"T" 3 WAY JOINT  
GIUNTO 3 VIE "T"  
3807/0..

**NUDO 4 VIAS CRUZ**  
JOINT À 4 VOIES À CROIX  
4 WAY CROSS-JOINT  
GIUNTO 4 VIE A CROCE  
3808/0..

**NIVELADOR M10**  
VÉRIN M10  
LEVELLER M10  
PIEDINO LIVELLATORE M10  
3813/00N

**RUEDA M10**  
ROUE  
CASTOR  
RUOTA  
232/00N

# \*MASTER 20X20

CR. BRILLO CHR. POLI BR. CHR CR. LUC.	INOX INOX	SAT S.S.S. INOX SAT	COLOR COULEUR COLOR COLORE
32	28	0P	
Fe	3 m	20x20x1,2mm	€/u
	o		
Zn	5-8 mm	Ø 5 mm	€/u
	o		
Zn	Ø 5 mm		€/u
	o		
inox s.s.	4-5 mm		€/u
	o		
plas	2 m	5 mm	15,5x11 €/m
	o		
plas	2 m	5 mm	15,5x6 €/m
	o		
plas	66 m	19X0,8	€/u
	o		
plas	transp.		€/u
	o		
Zn	4-8 mm		€/u
	o		
plas	20x20 mm		€/u
	o		negro o
plas	20x20 mm		€/u
	o		

**TUBO 20X20 mm**  
TUBE 20X20 mm  
TUBE 20x20 mm  
TUBO 20x20 mm  
3810/3..

**PINZA ESTANTE VIDRIO**  
BLOQUEO SEGURIDAD  
TAGUET MÉTALLIQUE  
AUTOBLOQUANT VERRE  
METALLIC GLASS  
SHELF-BLOCKING HOLDER  
REGGICRISTALLO  
CON BLOCCO  
1440/032

**PESTAÑA ESTANTE**  
ANTIDESLIZANTE  
SHELF SUPPORT  
TAGUET  
REGGIPIANO  
3824/032

**PINZA PARA VIDRIO**  
VERTICALES EN INOX  
SUPPORT VERRE VERTICAL FIXE  
CLAMP FIXED VERTICAL GLASS  
PINZA PER VETRI VERTICALI FISSI  
3828/028

**SUPERIOR DOBLE**  
COULISSE HAUTE DOBLE  
UPPER DOUBLE TRACK  
GUIDA SUPERIOR DOPPIA  
1681/109 TRANSP.

**CARRIL INFERIOR DOBLE**  
RAIL DOBLE INFÉRIEUR  
LOWER DOUBLE RAIL  
BINARIO DOPPIO INF.  
1683/109 TRANSP.

**CINTA ADHESIVA 2 CARAS**  
RUBAN ADHÉSIF DOUBLE FACE  
DOUBLE FACED ADHESIVE TAPE  
NASTRO BIADESIVO  
1546/000

**UNERO ADHESIVO**  
POIGNÉE ADHÉSIVE  
ADHESIVE DOOR PULL  
MANIGLIA ADESIVA  
1625/009

**CERRADURA DE SERRETA**  
SERRURE CRÉMAILLÈRE AMOVIBLE  
RATCHET LOCK  
SERRATURA CREMAGLIERA  
1502/032 DISTINTA LLAVE  
comb. variée, differ key, chiave distinta  
1501/032 MISMA LLAVE  
même comb. keyed alike, stessa chiave

**TAPÓN TUBO 20X20**  
EMBOUIT  
END-CAP  
COPRITESTA  
3811/002

**TAPÓN M10 TUBO 20X20**  
END-CAP with M10 hole  
EMBOUIT avec m10 trou  
COPRITESTA con foro M10  
3812/00N





RAL 9006 = color OP  
metal. OM= 032+50%

CR. BRILLO	BLANCO	NEGRO	COLOR
CH. POLI	BLANC	NOIR	COULEUR
BR. CHR.	WHITE	BLACK	COLOR
CR. LUC.	BIANCO	NERO	COLORE
<b>32</b>	<b>OB</b>	<b>ON</b>	<b>OP</b>

Fe	180x90 cm	50x50	€/u
----	-----------	-------	-----

## MALLAS

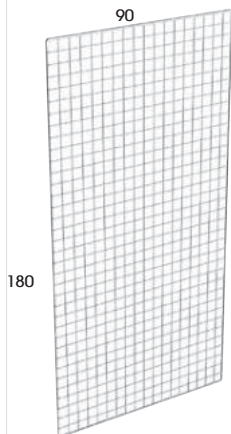

**MALLA 180 X 90 cm**  
GRILL PANEL 1800x900 mm  
PANNEAU À GRILLE 1800x900 mm  
PANNELLO GRIGLIATO 1800x900 mm  
\*175/0..

\*consultar

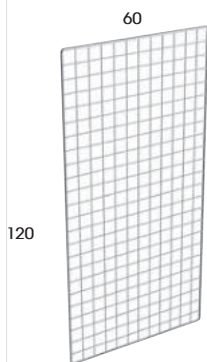

**MALLA 120 X 60 cm**  
GRILL PANEL 1200x600 mm  
PANNEAU À GRILLE 1200x600 mm  
PANNELLO GRIGLIATO 1200x600 mm  
\*178/0..

\*consultar

Fe	120x60 cm	50x50	€/u
----	-----------	-------	-----

## GÓNDOLA-EXPOSITOR

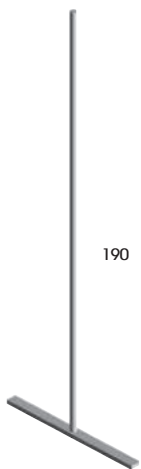

**PIE GÓNDOLA CON RUEDA 232**  
GONDOLA SELF-SUPPORTING UPRIGHT  
Castor Ø50 mm included  
GONDOLA MONTANT AUTO-PORTANT  
Roue Ø50 mm inclus  
MONTANTE GONDOLA  
Ruota Ø50 mm inclusa  
\*322/0..

o

**PIE GÓNDOLA CON NIVELADOR 231**  
GONDOLA SELF-SUPPORTING UPRIGHT  
Levellers included  
GONDOLA MONTANT AUTO-PORTANT  
Vérin inclus  
MONTANTE GONDOLA  
Piedino livellatore incluso  
\*324/0..

o

## BRIDAS



**SOPORTE MALLA PARED**  
WALL SUPPORT FOR GRILL PANEL  
SUPPORT A MUR POUR PANNEAU  
À GRILLE  
SUPPORTO A PARETE PER PANNELLO  
GRIGLIATO  
\*185/X..

o



**BRIDA Ø10/Ø10 mm**  
CLAMP Ø10/Ø10 mm  
ETAU Ø10/Ø10 mm  
MORSETTO Ø10/Ø10 mm  
\*187/X..

o



**BRIDA Ø25/Ø10 mm**  
CLAMP Ø25/Ø10 mm  
ETAU Ø25/Ø10 mm  
MORSETTO Ø25/Ø10 mm  
\*186/0..

o

## MALLAS

CR. BRILLO	BLANCO	NEGRO	COLOR
CH. POLI	BLANC	NOIR	COULEUR
BR. CHR.	WHITE	BLACK	COLOR
CR. LUC.	BIANCO	NERO	COLORE
<b>32</b>	<b>OB</b>	<b>ON</b>	<b>OP</b>

Fe			€/u
----	--	--	-----

o

Fe	300 mm		€/u
----	--------	--	-----

o

Fe	72x35 cm	12 kg/u	€/u
----	----------	---------	-----

o

Fe	300 mm		€/u
----	--------	--	-----

o

Fe	600x310 mm		€/u
----	------------	--	-----

\*o

## ACCESORIOS



**GANCHO**  
CROCHET  
HOOK  
BARRETTA  
\*335/X32 10 cm

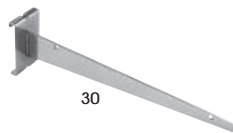

**CARTELA ESTANTE MADERA**  
SUPPORT TABLETTS BOIS  
WOOD SHELF BRACKET  
MENSOLA RIPIANO LEGNO  
\*318/X..

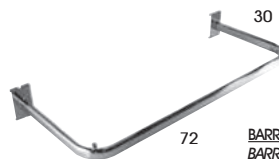

**BARRA PENDERIE**  
BARRE PENDERIE  
HANGING BAR  
BARRA APPENDERIA  
\*325/0..

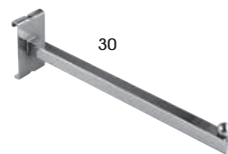

**PERROQUET PLANO**  
PENDERIE FRONTAL  
STRAIGHT ARM  
APPENDERIA FRONTALE  
\*339/0..



**CESTA REJILLA**  
GRID BASKET  
PANIER DE GRILLE  
CESTINO GRIGLIA  
\*345/0..

# BASIC - LOW COST



BASIC MAXI

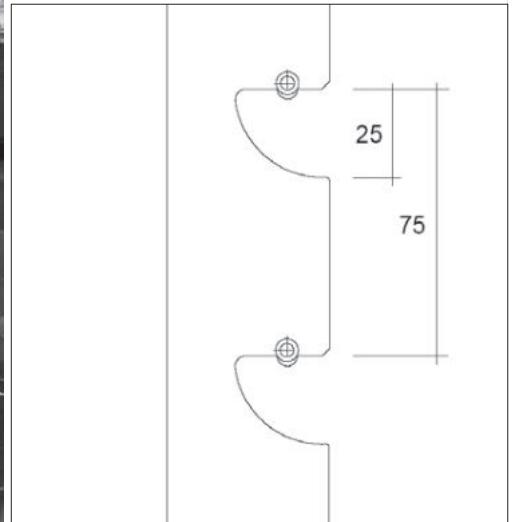

BASIC MINI

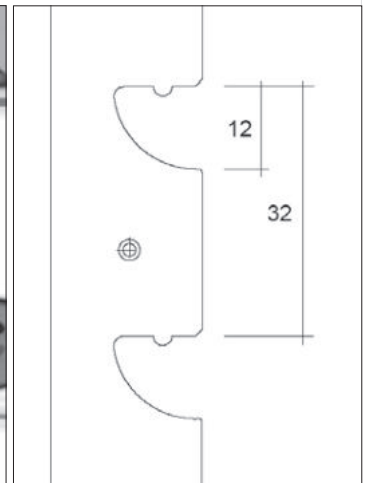
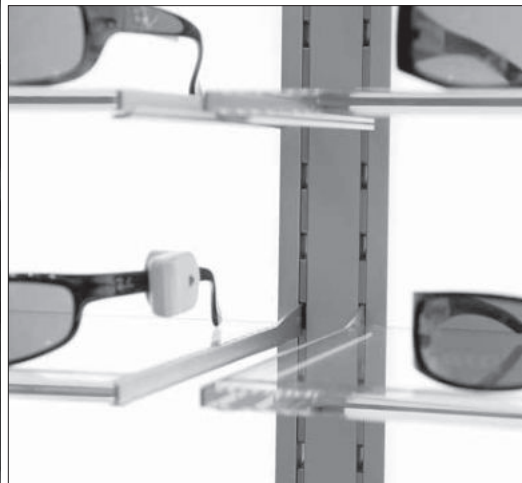

**\*BASIC MAXI**

INOX SAT  
INOX SAT  
S.S.S.  
INOX SAT  
**28**

INOX SAT  
INOX SAT  
S.S.S.  
INOX SAT  
**28**

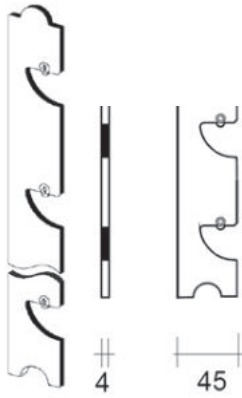

inox s.s.	1200 mm	45x4	€/u
-----------	---------	------	-----

**GUÍA CREMALLERA 1 CANAL**  
CREMAILLÈRE  
RACK  
CREMAGLIERA  
\*2500/028 derecha  
droite/right/destra  
\*2501/028 izquierda  
gauche/left/sinistra

\*consultar  
\*consultar

25	25
----	----

inox s.s.	25 mm	305 mm	€/u
-----------	-------	--------	-----

**CARTELA ESTANTE MADERA**  
SUPPORT TABLETTE BOIS  
WOOD SHELF BRACKET  
MENSOLA RIPIANO LEGNO  
\*2508/028 derecha  
droite/right/destra  
\*2509/028 izquierda  
gauche/left/sinistra

\*O  
\*O

inox s.s.	25 mm	355 mm	€/u
-----------	-------	--------	-----

**CARTELA ESTANTE MADERA**  
SUPPORT TABLETTE BOIS  
WOOD SHELF BRACKET  
MENSOLA RIPIANO LEGNO  
\*2510/028 derecha  
droite/right/destra  
\*2511/028 izquierda  
gauche/left/sinistra

\*O  
\*O

inox s.s.	355 mm	€/u
-----------	--------	-----

**CARTELA SUPPORT BRACKET MENSOLA**  
\*2514/028 derecha  
droite/right/destra  
\*2515/028 izquierda  
gauche/left/sinistra

\*O  
\*O

inox s.s.	305 mm	€/u
-----------	--------	-----

**CARTELA INTERMEDIA SUPPORT INTERMEDIAIRE INTERMEDIATE BRACKET MENSOLA INTERMEDIA**  
\*2516/028

\*O

inox s.s.	355 mm	€/u
-----------	--------	-----

**CARTELA INTERMEDIA SUPPORT INTERMEDIAIRE INTERMEDIATE BRACKET MENSOLA INTERMEDIA**  
\*2518/028

\*O

inox s.s.	25 mm	355 mm	€/u
-----------	-------	--------	-----

**CARTELA INCLINADA 30° SUPPORT INCLINÉE 30° SLOPPING BRACKET 30° MENSOLA INCLINATA 30°**  
\*2520/028 derecha  
droite/right/destra  
\*2521/028 izquierda  
gauche/left/sinistra

\*O  
\*O

inox s.s.	8 mm	105 mm	€/u
-----------	------	--------	-----

**CARTELA ESTANTE VIDRO SUPPORT TABLETTE VERRRE GLASS SHELF BRACKET MENSOLA RIPIANO VETRO**  
\*2527/028

\*O

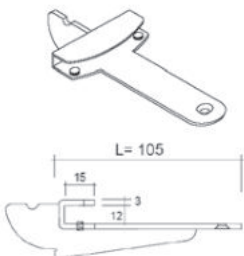

**\*BASIC MAXI**

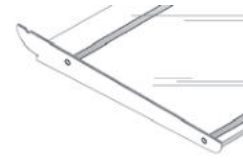

inox s.s.	8 mm	355 mm	€/u
			∞ 2551-2550 (x2)

**CARTELA ESTANTE VIDRO SUPPORT TABLETTE VERRRE GLASS SHELF BRACKET MENSOLA RIPIANO VETRO**  
\*2524/028 derecha  
droite/right/destra  
\*2525/028 izquierda  
gauche/left/sinistra

\*O  
\*O



inox s.s.	8 mm	355 mm	€/u
			2524-2525 ∞ 2551-2550 (x2)

**CARTELA INTERMEDIA SUPPORT INTERMEDIAIRE INTERMEDIATE BRACKET MENSOLA INTERMEDIA**  
\*2526/028

\*O

inox s.s.	300 mm	€/u
		∞ 2551-2550, 2552-2553

**CARTELA BARRA PENDERIE SUPPORT BARRE PENDERIE BRACKET HANGING BAR MENSOLA APPENDERIA**  
\*2528/028 derecha  
droite/right/destra  
\*2529/028 izquierda  
gauche/left/sinistra

\*O  
\*O

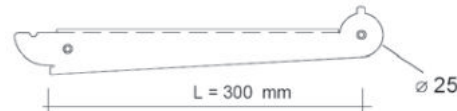
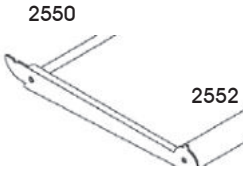

inox s.s.	355 mm	€/u
-----------	--------	-----

**CARTELA SUPPORT BRACKET MENSOLA**  
\*2514/028 derecha  
droite/right/destra  
\*2515/028 izquierda  
gauche/left/sinistra

\*O  
\*O

inox s.s.	305 mm	€/u
-----------	--------	-----

**CARTELA INTERMEDIA SUPPORT INTERMEDIAIRE INTERMEDIATE BRACKET MENSOLA INTERMEDIA**  
\*2516/028

\*O

inox s.s.	355 mm	€/u
-----------	--------	-----

**CARTELA INTERMEDIA SUPPORT INTERMEDIAIRE INTERMEDIATE BRACKET MENSOLA INTERMEDIA**  
\*2518/028

\*O

inox s.s.	25 mm	355 mm	€/u
-----------	-------	--------	-----

**CARTELA INCLINADA 30° SUPPORT INCLINÉE 30° SLOPPING BRACKET 30° MENSOLA INCLINATA 30°**  
\*2520/028 derecha  
droite/right/destra  
\*2521/028 izquierda  
gauche/left/sinistra

\*O  
\*O

inox s.s.	8 mm	105 mm	€/u
-----------	------	--------	-----

**CARTELA ESTANTE VIDRO SUPPORT TABLETTE VERRRE GLASS SHELF BRACKET MENSOLA RIPIANO VETRO**  
\*2527/028

\*O

inox s.s.	305 mm	€/u
		2528-2529 ∞ 2551-2550, 2552-2553

**CARTELA INTERMEDIA SUPPORT INTERMEDIAIRE INTERMEDIATE BRACKET MENSOLA INTERMEDIA**  
\*2530/028

\*O

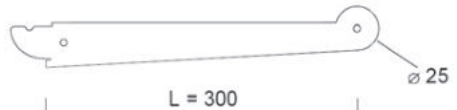
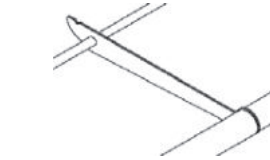

inox s.s.	300 mm	€/u
		∞ 2551-2550, 2552-2553

**CARTELA + BARRA PENDERIE SUPPORT + BARRE PENDERIE BRACKET + HANGING BAR MENSOLA + APPENDERIA**  
\*2532/028 derecha  
droite/right/destra  
\*2533/028 izquierda  
gauche/left/sinistra

\*O  
\*O

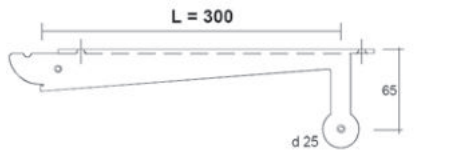

plas	Ø14	€/u
------	-----	-----

**VENTOSA VENTOUSE SUCTION VENTOSA**  
2556/009

O





# BASIC MAXI

INOX SAT  
INOX SAT  
S.S.S.  
INOX SAT  
**28**

inox s.s.	300 mm	€/u
2532-2533 ∅ 2551-2550, 2552-2553		

**CARTELA INTERMEDIA**  
SUPPORT INTERMEDIAIRE  
INTERMEDIATE BRACKET  
MENSOLA INTERMEDIA  
**\*2534/028**

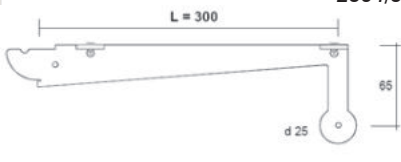

\*O

inox s.s.	380 + 200 mm	€/u
∅ 2528-2529-2530		

**BARRA TELESCÓPICA PENDERIE**  
BARRÉ TELESCOPIQUE PENDERIE  
TELESCOPIC HANGING BAR  
BARRA TELESCOPICA APPENDERIA  
**\*2536/028**

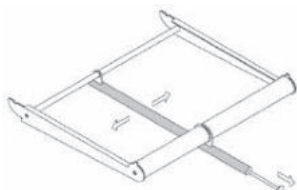

\*O

inox s.s.	380 + 200 mm	€/u
∅ 2532-2533-2534		

**BARRA TELESCÓPICA PENDERIE**  
BARRÉ TELESCOPIQUE PENDERIE  
TELESCOPIC HANGING BAR  
BARRA TELESCOPICA APPENDERIA  
**\*2537/028**

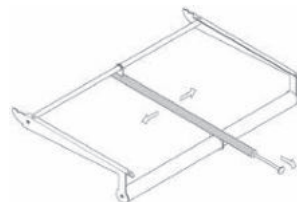

\*O

inox s.s.	300 mm	€/u
-----------	--------	-----

**PERROQUET PLANO**  
PENDERIE FRONTAL  
STRAIGHT ARM  
APPENDERIA FRONTALE  
**\*2538/028**



\*O

inox s.s.	300 mm	€/u
-----------	--------	-----

**PERROQUET INCLINADO 30°**  
PERROQUET INCLINÉE 30°  
SLOPING ARM 30°  
APPENDERIA INCLINADA 30°  
**\*2539/028**

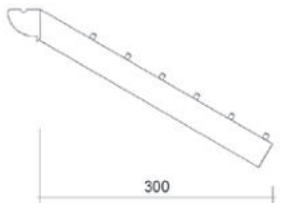

\*O

inox s.s.	300 mm	€/u
-----------	--------	-----

**PERROQUET PLANO "Z"**  
PENDERIE FRONTAL "Z"  
STRAIGHT ARM "Z"  
APPENDERIA FRONTALE "Z"  
**\*2540/028**

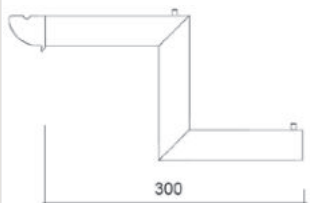

\*O

inox s.s.	200 mm	€/u
∅ 2554 (30x15)		

**GANCHO**  
CROCHET  
HOOK  
BARRETTA  
**\*2541/028**

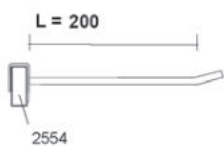

\*O

inox s.s.	300 mm	€/u
∅ 2554 (30x15)		

**PERROQUET PLANO**  
PENDERIE FRONTAL  
STRAIGHT ARM  
APPENDERIA FRONTALE  
**\*2542/028**

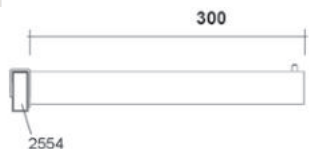

\*O

# BASIC MAXI

INOX SAT  
INOX SAT  
S.S.S.  
INOX SAT  
**28**

inox s.s.	300 mm	€/u
∅ 2554 (30x15)		

**PERROQUET INCLINADO**  
PERROQUET INCLINÉE  
SLOPING ARM  
APPENDERIA INCLINADA  
**\*2543/028**

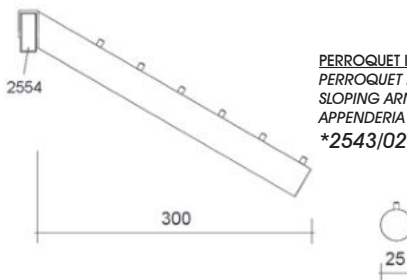

\*O

inox s.s.	25 mm	€/u
∅ 2554 (30x15)		

**CARTELA BARRA ACCESORIOS**  
SUPPORT BARRÉ ACCESSOIRES  
BRACKET FOR ACCESSORIES ROD  
MENSOLA TUBO PORTA-ACCESSORI  
**\*2546/028** derecha  
droite/right/destra  
**\*2547/028** izquierda  
gauche/left/sinistra

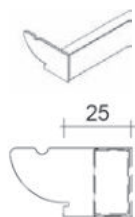

\*O

\*O

inox s.s.	50 mm	€/u
-----------	-------	-----

**PORTARÓTULO**  
SUPPORTÉTIQUETTE  
BRAND HOLDER  
SUPPORTO LOGO  
**\*2548/028** derecha  
droite/right/destra  
**\*2549/028** izquierda  
gauche/left/sinistra

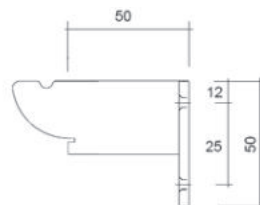

\*O

\*O

inox s.s.	L 3 m	∅10	€/m
-----------	-------	-----	-----

**TUBO Ø10**  
TUBE Ø10  
TUBE Ø10  
TUBO Ø10  
**\*2550/128**



\*O

**CONEXION ENTRE TUBO 2550 Y CARTELA**  
JOINT ENTRE LE TUBE 2550 ET LE SUPPORT  
JOINT BETWEEN TUBE 2550 AND BRACKET  
GIUNTO FRA TUBO 2550 E MENSOLA  
**\*2551/001**

\*O

**CONEXION ENTRE TUBO 2552 Y CARTELA**  
JOINT ENTRE LE TUBE 2552 ET LE SUPPORT  
JOINT BETWEEN TUBE 2552 AND BRACKET  
GIUNTO FRA TUBO 2552 E MENSOLA  
**\*2553/001**

\*O

inox s.s.	L 3 m	30x15	€/m
-----------	-------	-------	-----

**TUBO 30X15**  
TUBE 30X15  
TUBE 30X15  
TUBO 30X25  
**\*2554/128**

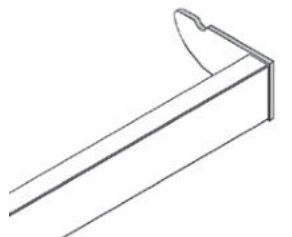

\*O

**\*BASIC MINI**

INOX SAT  
INOX SAT  
S.S.S.  
INOX SAT  
**28**

INOX SAT  
INOX SAT  
S.S.S.  
INOX SAT  
**28**

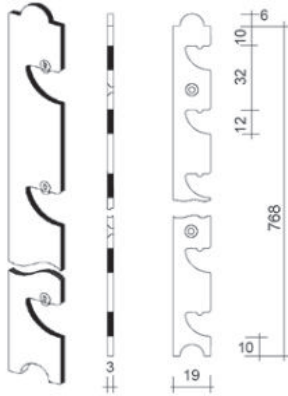

inox s.s.	∅ 768 mm	19x3	€/u
-----------	----------	------	-----

**GUÍA CREMALLERA 1 CANAL**  
CRÉMALLÈRE  
RACK  
CREMAGLIERA  
\*2560/028 derecha  
droite/right/destra  
\*2561/028 izquierda  
gauche/left/sinistra

\*O

\*O



Zn	∅ 15 mm	∅ 20	€/u
----	---------	------	-----

**CASQUILLO REDONDO Ø20**  
Accesorios MINI  
INSERT ROND Ø20  
Accessoires MINI  
ROUND SOCKET Ø20  
Fittings MINI  
BOCCOLA ROTONDA Ø20  
Accessori MINI  
\*2562/028

\*O

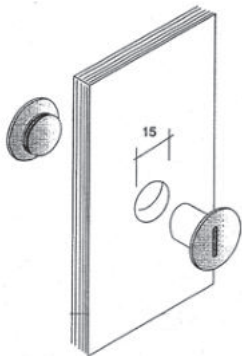
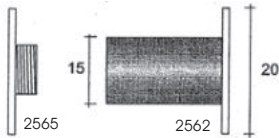

inox s.s.	∅ 20	€/u
-----------	------	-----

**FIJACIÓN POSTERIOR CASQUILLO 2562**  
FIXATION DERRIÈRE INSERT 2562  
BEHIND FIXING SOCKET 2562  
FISSAGGIO POSTERIORE BOCCOLA 2562  
\*2565/028

\*O



inox s.s.	160x180 mm	€/u
-----------	------------	-----

**SOPORTE GAFAS**  
SUPPORT LUNETTES  
GLASSES SUPPORT  
SUPPORTO OCCHIALI  
\*2563/028

\*O

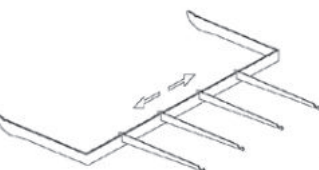
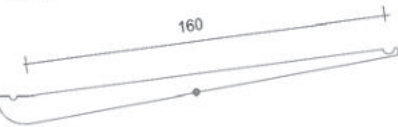

inox s.s.	778 mm	€/u
-----------	--------	-----

**SOPORTE 4 GAFAS**  
SUPPORT 4 LUNETTES  
4 GLASSES SUPPORT  
SUPPORTO 4 OCCHIALI  
\*2564/028

\*O

**\*BASIC MINI**

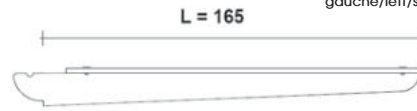

inox s.s.	165 mm	€/u
	∅ 2571-2570+2556	

**CARTELA ESTANTE VIDRO**  
SUPPORT TABLETTE VERRE  
GLASS SHELF BRACKET  
MENSOLA RIPIANO VETRO  
\*2566/028 derecha  
droite/right/destra  
\*2567/028 izquierda  
gauche/left/sinistra

\*O

\*O



inox s.s.	€/u
-----------	-----

**CARTELA ESTANTE VIDRO**  
SUPPORT TABLETTE VERRE  
GLASS SHELF BRACKET  
MENSOLA RIPIANO VETRO  
\*2568/028

\*O

VIDRIO NO INCLUIDO  
VERRE NON INCLUS  
GLASS NOT INCLUDED  
VETRO NON INCLUSO

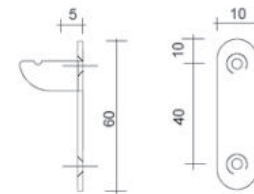

inox s.s.	60 mm	€/u
-----------	-------	-----

**PORTARÓTULO**  
SUPPORTÉTIQUETTE  
BRAND HOLDER  
SUPPORTO LOGO  
\*2572/028 derecha  
droite/right/destra  
\*2573/028 izquierda  
gauche/left/sinistra

\*O

\*O



inox s.s.	∅ 8	€/m
-----------	-----	-----

**TUBO Ø8**  
TUBE Ø8  
TUBE Ø8  
TUBO Ø8  
\*2570/128

\*O

**CONEXION ENTRE TUBO 2570 Y CARTELA**  
JOINT ENTRE LE TUBE 2570 ET LE SUPPORT  
JOINT BETWEEN TUBE 2570 AND BRACKET  
GIUNTO FRA TUBO 2570 E MENSOLA  
\*2571/001

\*O



plac	∅ 14	€/u
------	------	-----

**VENTOSA**  
VENTOUSE  
SUCTION  
VENTOSA  
**2556/009**

O

# CONCEPT - LOW COST



# CONCEPT

PL. MATE  
ALU. MAT  
ALU. MATT  
ALL. NAT  
**01**



Al	‡ 210/350cm	Ø40	€/u
----	-------------	-----	-----

**MONTANTE TELESCOPICO COMPLETO**  
MÂT TÉLESCOPIQUE COMPLET  
COMPLET TELESCOPIC ROD  
PIANTANA TELESCOPICA COMPLETA  
**\*2700/301**

\*o

Al	3 m	Ø40	€/u
----	-----	-----	-----

**TUBO Ø40**  
TUBE Ø40  
TUBE Ø40  
TUBO Ø40  
**\*2701/301**

\*o

Al		Ø40	€/u
----	--	-----	-----

**BASE DE ALUMINIO**  
BASE EN ALUMINIUM  
ALUMINIUM BASE  
BASE DI ALLUMINIO  
**\*2702/001**

\*o

plas		Ø40	€/u
------	--	-----	-----

**BASE DE PLÁSTICA NEGRA**  
BASE EN PLASTIQUE NOIR  
BLACK PLASTIC BASE  
BASE DI PLASTICA NERA  
**\*2703/00N**

\*o

plas		Ø40	€/u
------	--	-----	-----

**EMPALMADOR TUBO Ø40**  
JOINT COLONNES TUBE Ø40  
COLUMNS JOINT TUBE Ø40  
GIUNZIONE PIANTANE TUBO Ø40  
**\*2707/00N**

\*o

plas		Ø40	€/u
------	--	-----	-----

**TAPA TUBO Ø40**  
BOUCHON TUBE Ø40  
END-CAP UPRIGHT TUBE Ø40  
COPRITESTA PIANTANA TUBO Ø40  
**\*2708/001**

\*o

# CONCEPT

PL. MATE  
ALU. MAT  
ALU. MATT  
ALL. NAT  
**01**



Al		Ø40	€/u
----	--	-----	-----

**NUDO DE ALUMINIO**  
JOINT EN ALUMINIUM  
ALUMINIUM JOINT  
GIUNTO DI ALLUMINIO  
**\*2711/001**

\*o



Fe	275 mm	RAL9003	€/u
----	--------	---------	-----

**CARTELA CENTRAL**  
SUPPORT CENTRAL  
CENTRAL BRACKET  
MENSOLA ICENTRALE

**\*2758/00M** derecha  
droite/right/destra  
**\*2759/00M** izquierda  
gauche/left/sinistra

\*o

\*o

plas		Ø20	€/u
------	--	-----	-----

**VENTOSA**  
VENTOUSE  
SUCTION  
VENTOSA  
**319/009**

o

plas		Ø14	€/u
------	--	-----	-----

**VENTOSA**  
VENTOUSE  
SUCTION  
VENTOSA  
**2556/009**

o

Al	4 mm	Ø500	€/u
----	------	------	-----

**ESTANTE REDONDO+ANCLAJES**  
TABLETTE CIRCULAIRE+ FIXATIONES  
ROUND SHELF + JOINTS  
RIPIANO CIRCOLARE+FISSAGGI  
**\*2718/001**

\*o



plas	420x390	5 mm	€/u
------	---------	------	-----

**CARTELA LATERAL + ESTANTE**  
SUPPORT LATERAL + TABLETTE  
BRACKET + SHELF  
MENSOLA + RIPIANO

**\*2719/009** metacrilato  
métacrylate, plexiglass

\*o



MD plas	30,5x30,5x20 cm	€/u
---------	-----------------	-----

**VITRINA CON CERRADURA**  
VETRINE AVEC SERRURE  
SHOWCASE WITH LOCK  
VETRINA CON SERRATURA  
**\*2760/001**

\*o

NEGRO  
NOIR  
BLACK  
NERO

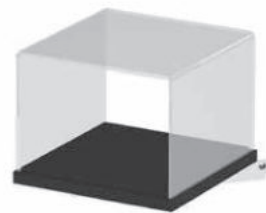

Al	30 mm M8	Ø10	€/u
----	----------	-----	-----

**SOPORTE LATERAL PARA MUEBLES**  
SUPPORT LATERAL POUR MOBLES  
LATERAL SUPPORT FOR FURNITURE  
SUPPORTO LATERALE PER MOBILI  
**\*2736/001**

\*o





# CONCEPT

PL. MATE  
ALU. MAT  
ALU. MATT  
ALL. NAT  
**01**

MD	39,5x39,5x39 cm	€/u
	∞ 2736 (x2)	

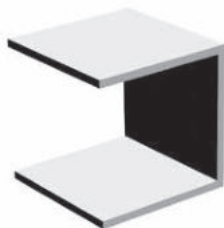

**MÓDULO LATERAL MADERA**  
Module latéral bois  
Wood lateral module  
modulo laterale legno  
**\*2737/00B**

BLANCO  
BLANC  
WHITE  
BIANCO

\*O

MD	88,4x39,5x39 cm	€/u
	∞ 2736 (x4)	



**MÓDULO CENTRAL MADERA**  
Module central bois  
Wood central module  
modulo centrale legno  
**\*2739/00B**

BLANCO  
BLANC  
WHITE  
BIANCO

\*O

Al	6 mm	€/u
----	------	-----



**SOPORTE INCLINABLE ESTANTE**  
SUPPORT INCLINABLE TABLETTE  
TILT BRACKET SHELF  
SUPPORTO INCLINABILE RIPIANO  
**\*2720/001**

\*O

Al	6 mm	€/u
----	------	-----



**SOPORTE INCLINABLE ESTANTE**  
SUPPORT INCLINABLE TABLETTE  
TILT BRACKET SHELF  
SUPPORTO INCLINABILE RIPIANO  
**\*2721/001**

\*O

Al	6 mm	€/u
	0°-45°-90°	



**SOPORTE INCLINABLE FIJO**  
SUPPORT INCLINABLE FIXE  
FIX TILT BRACKET  
SUPPORTO INCLINABILE FISSO  
**\*2722/001**

\*O

Al	6 mm	€/u
	0°-45°-90°	



**SOPORTE INCLINABLE REGULABLE**  
SUPPORT INCLINABLE RÉGLABLE  
ADJUSTABLE TILT BRACKET  
SUPPORTO INCLINABILE REGOLABILE  
**\*2723/001**

\*O

Al	300x400 mm	4 mm	€/u
----	------------	------	-----

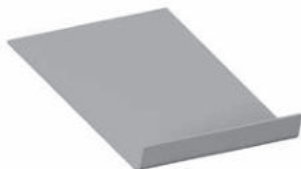

**ESTANTE METACRILATO**  
TABLETTE MÉTHACRYLATE  
SHELF METHACRYLATE  
RIPIANO PLEXIGLASS  
**\*2724/009**

BLANCO  
BLANC  
WHITE  
BIANCO

\*O

Al	4 mm	∅350	€/u
----	------	------	-----



**ESTANTE METACRILATO**  
TABLETTE MÉTHACRYLATE  
SHELF METHACRYLATE  
RIPIANO PLEXIGLASS  
**\*2725/009**

BLANCO  
BLANC  
WHITE  
BIANCO

\*O

# CONCEPT

PL. MATE  
ALU. MAT  
ALU. MATT  
ALL. NAT  
**01**

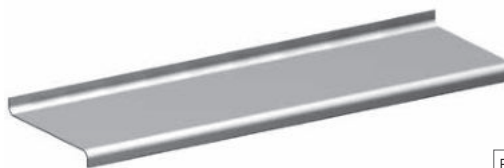

Fe	2 mm	RAL9006	€/u
----	------	---------	-----

**ESTANTE DE CHAPA**  
TABLETTE TÔLE  
METAL SHEET SHELF  
RIPIANO METALLICO  
**\*2726/00M 119x42 cm**  
**\*2729/00M 93x42 cm**

\*O  
\*O

MD	wengue	€/u
----	--------	-----

**KIT BASES ROTATORIAS DE MADERA**  
KIT PIVOTANT BASES EN BOIS  
KIT SWIVELING WOODEN BASES  
KIT ORIENTABLE BASI IN LEGNO  
**\*2763/00M h=20 cm**

\*O



200

400

2764

Al	125 mm M8	€/u
----	-----------	-----



**SOPORTE PARA BUSTOS**  
SUPPORT POUR BUSTE  
BUST SUPPORT  
SUPPORTO BUSTO  
**\*2713/001**

\*O

plas		€/u
------	--	-----



**BUSTO MUJER**  
BUSTE FÉMMME  
WOMAN BUST  
BUSTO DONNA  
**\*2750/00B**

\*O

BLANCO  
BLANC  
WHITE  
BIANCO



# metal.



# Outlet

Herrajes para madera y vidrio

**TARIFA 63**

01/07/2023

## METAL - OUTLET

HERRAJES PARA DUCHAS - ACCESSOIRES DE DOUCHE  
SCHOWER GLASS FITTINGS - ACCESSORI PER DOCCIA

## UNIÓN ESTANTERÍA

ENSEMBLES ÉTAGÈRES - JOINTS SHELVES - UNIONI SCAFFALI



ESCUADRA 3 VIDRIOS  
PIECE ASSEMBLAGE 3 VERRES  
ASSEMBLY PIECE 3 GLASSES  
PEZZO UNIONE 3 VETRI  
\*74/032

Zn	max5mm	€/u
----	--------	-----

CR. BRILLO CHR. POLI BR. CHR CR. LUC.	CR. MATE CHR. M M. CHR CR. OPAC
32	31

\*o

## COMPL. MUEBLES

ACCESSOIRES POUR MEUBLES  
FURNITURE FITTINGS  
ACCESSORI PER MOBILI



TIRADOR  
BOUTON  
KNOB  
POMOLO  
\*1529/0...

CR. BRILLO CHR. POLI BR. CHR CR. LUC.	CR. ORO CHR. DOR GOLD. C CR. ORO	BLANCO BLANC WHITE BIANCO	NEGRO NOIR BLACK NERO	CR. MATE CHR. M M. CHR CR. OPAC
32	33	0B	0N	31

Zn	€/u
----	-----

\*o

\*o

CR. BRILLO CHR. POLI BR. CHR CR. LUC.	CR. ORO CHR. DOR GOLD. C CR. ORO	BLANCO BLANC WHITE BIANCO	NEGRO NOIR BLACK NERO	CR. MATE CHR. M M. CHR CR. OPAC
32	33	0B	0N	31

Cu	8-10 mm	20 kg/2u	2 x Ø12	€/u
----	---------	----------	---------	-----



Ø 12

BISAGRA PIVOTANTE  
CHARNIÈRE DE PIVOTEMENT  
PIVOTING HINGE  
CERNIERA CARDINE  
\*1967/032  
JUEGOS DE 2 UNIDADES  
JEUX DE 2 UNITÉS  
SET 2 PIECES  
SET 2 PEZZI

\*o



BISAGRA GOLPE ARREMETIDA  
CHARNIÈRE ANGULAIRE  
CORNER HINGE  
CERNIERA A SCATTO  
\*1468/032

\*o



PLACA PARA TRASFORMAR LA  
BISAGRA 1468 EN VIDRIO-VIDRIO  
PLAQUE POUR TRANSFORMER LE  
CHARNIÈRE 1468 EN VERRE-VERRE  
PLATE TO TRANSFORM THE 1468  
HINGE IN GLASS-GLASS  
PIASTRA PER TRASFORMARE LA  
CERNIERA 1468 IN VETRO-VETRO  
\*1469/032

\*o

## METAL - OUTLET

HERRAJES PARA DUCHAS - ACCESSOIRES DE DOUCHE  
SCHOWER GLASS FITTINGS - ACCESSORI PER DOCCIA



CERRADURA PUERTA BATIEN  
SERRURE PORTE BATTANTE  
SWINGING DOOR LOCK  
SERRATURA PORTA BATTENTE  
\*1508/032 DISTINTA LLAVE  
comb. variée, differ key, chiave distinta



CERRADURA x PUERTA ALUMINIO  
SERRURE x PORTE D'ALUMINIUM  
LOCK x ALUMINIUM DOOR  
SERRATURA x PORTA DI ALLUMINIO  
fresado en el aluminio  
fraisage en aluminium  
milling in aluminium  
fresatura nell'aluminio  
\*1479/031 DISTINTA LLAVE  
comb. variée, differ key, chiave distinta

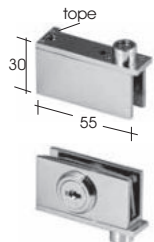

conjunto derecha  
(1965+1966)

BISAGRA PIVOTANTE CON  
CERRADURA + BISAGRA  
SUPERIOR SIN CERRADURA  
CHARNIÈRE DE PIVOTEMENT  
AVEC SERRURE + CHARNIÈRE SUP.  
PIVOTING HINGE WITH LOCK  
+ UPPER HINGE  
CERNIERA CARDINE CON SERRATURA  
+ CERNIERA SUP.

\*1966/032 der. sup.

\*1965/032 der. inf.

droite/right/destra

Se venden en

JUEGOS DE 2 U. DERECHA  
JEUX 2 UNITÉS, DROITE  
SET 2 PIECES, RIGHT  
SET 2 PEZZI, DESTRA

CR. BRILLO CHR. POLI BR. CHR CR. LUC.	CR. MATE CHR. M M. CHR CR. OPAC	CR. ORO CHR. DOR GOLD. C CR. ORO
32	31	33

Zn	5-10mm	Ø 19	€/u
----	--------	------	-----

\*o

Zn	19x21mm	€/u
----	---------	-----

\*o

Cu	6-8 mm	18 kg/2u	€/u
----	--------	----------	-----

55x30	€/u
-------	-----

\*o

\*o

## LAMPARA "UV"

PEGADO UV - COLLAGE "UV"  
"UV" LAMP GLUE SYSTEM - INCOLLAGGIO "UV"



IRRADIADOR "UV" 250W "UVAHAND"  
LAMPE "UV" 250W "UVAHAND"  
"UV" LAMP 250W "UVAHAND"  
LAMPADA "UV" W "UVAHAND"  
\*9132/000

BRUTO BRUT GREZZO	INOX INOX INOX	SAT SAT SAT
00	28	

250 W	€/u
-------	-----

\*o

## ACCESORIOS PARA PEGAMENTO UV



CERRADURA VID.-VID. 180° x PEGAMENTO "UV"  
SERRURE VERRE-VERRE 180° x COLLAGE "UV"  
GLASS-GLASS 180° LOCK x "UV" GLUE  
SERRATURA VETRO-VETRO 180° x COLLA "UV"  
\*1972/028

inox s.s.	UV	Ø 28	€/u
--------------	----	------	-----

\*o



40-50

PIE CON NIVELADOR x PEGAMENTO "UV"  
BASÉ AVEC NIVELEUR x COLLAGE "UV"  
BASE WITH LEVELER x "UV" GLUE  
BASE CON LIVELLATORE x COLLA "UV"  
\*1978/028

inox s.s.	UV	Ø 60	€/u
--------------	----	------	-----

\*o



VENTOSA 90° AJUSTABLE x PEGAMENTO "UV"  
VENTOUSE RÉGLABLE 2 COUPS x COLLAGE "UV"  
ADJUSTABLE SUCTION LIFTER 2 CUPS x "UV" GLUE  
VENTOSA DOPPIA REGOLABILE x COLLA "UV"  
\*9196/000

inox s.s.	Ø 55	€/u
--------------	------	-----

\*o

# cotek.



# Outlet

Herrajes cotek

**TARIFA 63**

01/07/2023

# COTEK - OUTLET

CORREDERA PARA DUCHAS - COULISSANTS DOUCHE  
 SCHOWER SLIDING DOOR - SCORREVOLI PER DOCCIA

## TONDO

Peso max: 40 kg/puerta  
 Vidrio: 8-10 mm

Poids max: 40 kg/porte  
 Verre: 8-10 mm

Max weight: 40 kg/door  
 Glass: 8-10 mm

Peso max: 40 kg/porta  
 Vetro: 8-10 mm

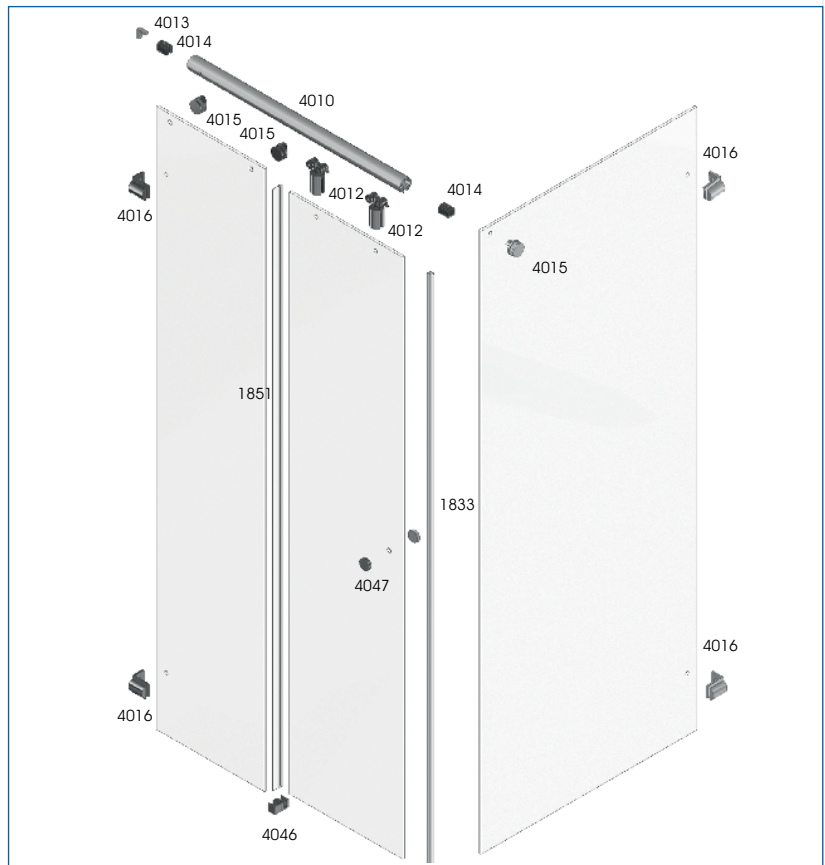
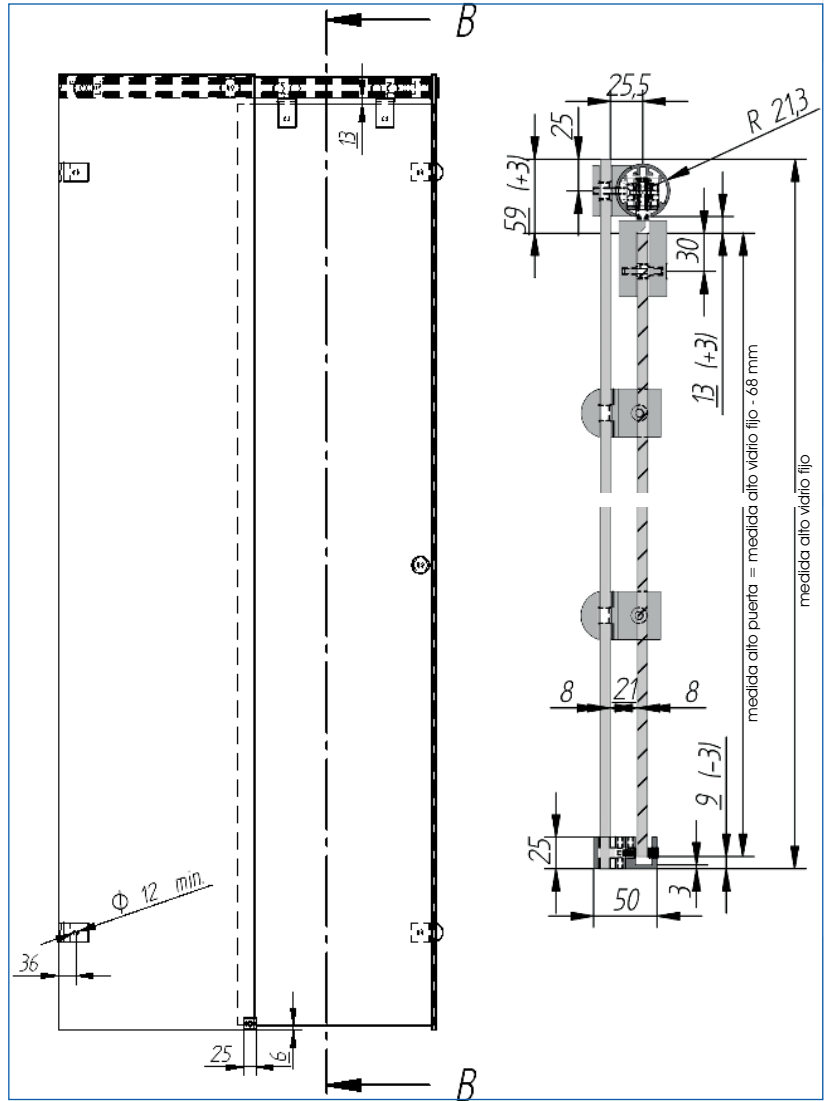

# COTEK - OUTLET

CORREDERA PARA DUCHAS - COULISSANTS DOUCHE  
SCHOWER SLIDING DOOR - SCORREVOLI PER DOCCIA

PL. BR ALU. BR ALL. LUC	CR. BRILLO CH-R. POLI BR. CHR CR. LUC.	PLÁSTICO PLASTIQUE PLASTICA
02	32	09



CARRIL  
COULISSE HAUTE  
UPPER TRACK  
GUIDA SUPERIORE  
**\*4010/102**

Al	2 m	Ø43	€/m
----	-----	-----	-----

Ø43 mm



COJINETE  
CHARLOT  
ROLLER  
CUSCINETTO  
**\*4011/032**

Cu	20 kg/u	8-10mm	€/u
	Ø 14-15 mm		



ANCLAJE VID.FIJO -CARRIL  
FIXATION VERRE-COULISSE  
CONNEXION GLASS-TRACK  
CONNESSIONE VETRO-GUIDA  
**\*4012/032**

Cu	8-10 mm	€/u
	Ø 14-15 mm	



ANCLAJE CARRIL-PARED  
FIXATION MUR-COULISSE  
CONNEXION WALL-TRACK  
CONNESSIONE PARETE-GUIDA  
**\*4013/032**

Cu	€/u
----	-----



STOP INTERIOR CARRIL  
STOP CHARLOT  
STOP ROLLER  
STOP CUSCINETTO  
**\*4014/009**

plas	€/u
------	-----



CONEXIÓN 90° CARRIL-VID. FIJO  
FIXATION VERRE-COULISSE  
CONNEXION GLASS-TRACK  
CONNESSIONE VETRO-GUIDA  
**\*4015/032**

Cu	8-10 mm	€/u
	Ø 14-15 mm	



GUÍA SUELO  
GUIDAGE AU SOL  
FLOOR GUIDE  
GUIDA A PAVIMENTO  
**4046/032**

Cu	6-10 mm	€/u
----	---------	-----



MORSETO VIDRIO-PARED  
FIXATION VERRE-MUR  
BRACKET GLASS-WALL  
MORSETTO VETRO-PARETE  
**\*4016/032**

Cu	8-10 mm	€/u
	Ø 14-15 mm	



POMO  
POIGNEÉ  
KNOB  
POMO  
**4047/032**

Cu	6-10 mm	€/u
	Ø 10 mm	



"U" INOX PULIDO  
U INOX POLI  
U POLISHED STAINLESS STEEL  
U INOX LUCIDO  
**4375/122** 15x15x15 mm

inox s.s.	3 m	€/m
-----------	-----	-----

**4376/122** 15x12x15x1 mm

**4377/122** 25x15x25x1 mm

	max. 12 mm	
	max. 8 mm	
	max. 12 mm	



PERFIL MAMPARAS  
PROF. ÉTANCHEITÉ  
SEAL  
GIUNTA  
**1833/109**

pvc	2,2 m	8-10mm	€/m
-----	-------	--------	-----



PERFIL LATERAL CORREDERA  
PROF. ÉTANCHEITÉ COULISSANT  
SLIDING DOOR SEAL  
GIUNTA PORTA SCORREVOLE  
**1851/109**

pvc	2,2 m	8mm	€/m
-----	-------	-----	-----

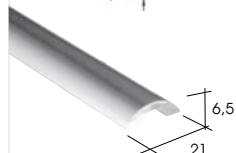

PERFIL BURLETE DE ALUMINIO  
PROFILE LEVRE-UO  
LIP-UP PROFILE  
PROFILO VERTICALE  
**1831/202**

Al	2 m	21X6,5	€/m
----	-----	--------	-----

# COTEK - OUTLET

CORREDERA PARA DUCHAS - COULISSANTS DOUCHE  
SCHOWER SLIDING DOOR - SCORREVOLI PER DOCCIA

CR. BRILLO CH-R. POLI BR. CHR CR. LUC.
32



KIT 1 puerta + fijo 90°  
1 PORTE + 1 FIXE 90°  
1 DOOR + 1 FIXED 90°  
1 PORTA + 1 FISSO 90°

## KIT BASE

4010/102 2 m.  
4011/032 2 u.  
4012/032 2 u.  
4013/032 1 u.  
4014/009 2 u.  
4015/032 1 u.  
4046/032 1 u.  
4047/032 1 u.  
1851/109 2,2 m (8 mm)  
**\*4018/B32**

## KIT BASE + U INOX

4010/102 2 m.  
4011/032 2 u.  
4012/032 2 u.  
4013/032 1 u.  
4014/009 2 u.  
4015/032 1 u.  
4046/032 1 u.  
4047/032 1 u.  
1851/109 2,2 m (8 mm)  
4376/122 6 m (8 mm)  
1833/109 2,2 m (8-10mm)  
**\*4018/U32**

## KIT BASE + 4016

4010/102 2 m.  
4011/032 2 u.  
4012/032 2 u.  
4013/032 1 u.  
4014/009 2 u.  
4015/032 1 u.  
4046/032 1 u.  
4047/032 1 u.  
1851/109 2,2 m (8 mm)  
4016/032 4 u.  
1833/109 2,2 m (8-10mm)  
**\*4018/M32**

NO incluidos:  
1831/132

## KIT 1 puerta 180°

1 PORTE 180°  
1 DOOR 180°  
1 PORTA 180°

## KIT BASE

4010/102 2 m.  
4011/032 2 u.  
4012/032 2 u.  
4013/032 2 u.  
4014/009 2 u.  
4046/032 1 u.  
4047/032 1 u.  
1851/109 2,2 m (8 mm)  
**\*4017/B32**

## KIT BASE + U INOX

4010/102 2 m.  
4011/032 2 u.  
4012/032 2 u.  
4013/032 2 u.  
4014/009 2 u.  
4046/032 1 u.  
4047/032 1 u.  
1851/109 2,2 m (8 mm)  
4376/122 3 m (8 mm)  
1833/109 2,2 m (8-10mm)  
**\*4017/U32**

## KIT BASE + 4016

4010/102 2 m.  
4011/032 2 u.  
4012/032 2 u.  
4013/032 2 u.  
4014/009 2 u.  
4046/032 1 u.  
4047/032 1 u.  
1851/109 2,2 m (8 mm)  
4016/032 2 u.  
1833/109 2,2 m (8-10mm)  
**\*4017/M32**

NO incluidos:  
1831/132

GALGA AGUJEROS 4010  
OUTIL FORAGE 4010  
TOOL TO DRILL 4010  
UTENSILE PER FORARE 4010  
**\*4019/000**



HASTA 200 CM  
VIDRIO 8 MM

HASTA 200 CM  
VIDRIO 8 MM

## COTEK - OUTLET

HERRAJES PARA DUCHAS - ACCESSOIRES DE DOUCHE  
SCHOWER GLASS FITTINGS - ACCESSORI PER DOCCIA

CR. BRILLO CHR. POLI BR. CHR CR. ILLC.	CR. MATE CHR. M M. CHR CR. OPAC	INOX INOX POLI P. S. S. INOX ILLC.	BR INOX SAT S. S. S. INOX SAT
32	31	22	28

### VALENCIA 6/10



N.D.

BISAGRA VIDRIO-VIDRIO 180°  
CHARNIÈRE VERRE-VERRE 180°  
HINGE GLASS-GLASS 180°  
CERNIERA VETRO-VETRO 180°  
\*4316/028

inox s.s.	20 kg/u	4 x Ø 14 mm	€/u
6-10 mm	160x20 mm	0°-90°	*o



HERRAJE FIJO 90° VIDRIO-VIDRIO  
FIXATION VERRE-VERRE 90°  
BRACKET GLASS-GLASS 90°  
MORSETTO VETRO-VETRO 90°  
\*4318/028

inox s.s.	2 x Ø 14 mm	€/u
6-10 mm	95x95 mm	*o

### MENORCA INOX



BISAGRA PARED-VIDRIO  
CHARNIÈRE MUR-VERRE  
HINGE WALL-GLASS  
CERNIERA PARETE-VETRO  
\*4187/022 INOX 304

inox s.s.	112x55 mm	€/u
8-10 mm	22 kg/u	0°-90°-180°

### MARBELLA 8/10



90

HERRAJE FIJO 90° PARED-VIDRIO  
FIXATION MUR-VERRE 90°  
BRACKET WALL-GLASS 90°  
MORSETTO PARETE-VETRO 90°  
\*4417/032

Cu	90x55 mm	€/u
8-10 mm	2x Ø 16 mm	*o

### SEVILLA 8/12



117

BISAGRA AUTOMÁTICA  
VIDRIO-VIDRIO 180°  
CHARNIÈRE AUTOMATIQUE  
VERRE-VERRE 180°  
AUTOMATIC HINGE  
GLASS-GLASS 180°  
CERNIERA AUTOMÁTICA  
VETRO-VETRO 180°  
\*4147/Z32

Zn	90x117 mm	€/u
8-12 mm	22 kg/u	0°-90°-180°

## COTEK - OUTLET

HERRAJES PARA DUCHAS - ACCESSOIRES DE DOUCHE  
SCHOWER GLASS FITTINGS - ACCESSORI PER DOCCIA

CR. BRILLO CHR. POLI BR. CHR CR. ILLC.	CR. MATE CHR. M M. CHR CR. OPAC	INOX INOX POLI P. S. S. INOX ILLC.	BR INOX SAT S. S. S. INOX SAT
32	31	22	28

### CURVO 6/8



BISAGRA VIDRIO-VIDRIO 180°  
CHARNIÈRE VERRE-VERRE 180°  
HINGE GLASS-GLASS 180°  
CERNIERA VETRO-VETRO 180°  
\*4113/032

Cu	20 kg/u	3x Ø 14 mm	€/u
8 mm	122x40mm	0°-90°	*o

APTA PARA VIDRIO CURVADO  
APPROPRIÉ POUR VERRE COURBÉ  
SUITABLE FOR CURVED GLASS  
IDONEA PER VETRO CURVATO

### JEREZ 8/10



32

105

42

BISAGRA VIDRIO-VIDRIO 90°  
CHARNIÈRE VERRE-VERRE 90°  
HINGE GLASS-GLASS 90°  
CERNIERA VETRO-VETRO 90°  
\*4112/032

Cu	15 kg/u	90x32mm	€/u
8-10 mm	90x32mm	0°-90°	*o

### UNICA 6/8



BISAGRA VIDRIO-VIDRIO 180°  
CHARNIÈRE VERRE-VERRE 180°  
HINGE GLASS-GLASS 180°  
CERNIERA VETRO-VETRO 180°  
\*4115/032 der.  
droite/right/destra  
\*4116/032 izq.  
gauche/left/sinistra

Cu	15 kg/u	4x Ø 14 mm	€/u
6-8 mm	80x80mm	0°-90°	*o

APTA PARA VIDRIO CURVADO APPROPRIÉ POUR VERRE COURBÉ SUITABLE FOR CURVED GLASS IDONEA PER VETRO CURVATO	FIJO FIXÉ FIXED FISSO	FIJO FIXÉ FIXED FISSO
	80	
4115/032		4116/032

### ARNO

PUERTA BATIENTE SIMPLE PARA BAÑERA  
PORTE BATTANTE SIMPLE POUR BAIGNOIRE  
SIMPLE SWINGING DOOR FOR BATHTUB  
PORTA VA E VIENI SEMPLICE PER VASCA  
VIDRIO NO INCLUIDO  
VERRE NON INCLUS, GLASS NOT INCLUDED, VETRO NO INCLUSO  
\*4940/00B BLANCO

Al	6 mm	€/u
----	------	-----

\*o

### ARNO

FIJO + PUERTA BATIENTE PARA BAÑERA  
VERRE FIXE + PORTE BATTANTE POUR BAIGNOIRE  
FIXED GLASS + SWINGING DOOR FOR BATHTUB  
VETRO FISSO + PORTA VA E VIENI PER VASCA  
VIDRIO NO INCLUIDO  
VERRE NON INCLUS, GLASS NOT INCLUDED, VETRO NO INCLUSO  
\*4942/00B BLANCO

Al	6 mm	€/u
----	------	-----

\*o



ALTO TOTAL= 1450 mm  
hauteur totale, total glass, altezza totale  
VIDRIO: 6 mm  
verre, glass, vidrio  
ALTO VIDRIO= 1425 mm  
hauteur verre, height glass, altezza vetro  
ANCHO MAX. = 800 mm  
largeur max. = 800 mm  
ax. width = 800 mm  
larghezza mass. = 800 mm



ALTO TOTAL= 1450 mm  
hauteur totale, total glass, altezza totale  
VIDRIO: 6 mm  
verre, glass, vidrio  
ALTO VIDRIO PUERTA= 1425 mm  
hauteur verre porte, height door glass,  
altezza vetro porta  
ALTO VIDRIO FIJO= 1450 mm  
hauteur verre fixe, height fixed glass, altezza  
vetro fisso  
ANCHO MAX. PUERTA= 800 mm  
largeur max. porte= 800 mm  
max. width door = 800 mm  
larghezza mass. porta= 800 mm  
ANCHO MIN. FIJO= 520 mm  
largeur min. porte= 520 mm  
min. width door = 520 mm  
larghezza min. porta= 520 mm

BARRA REFUERZO PARED VIDRIO 50 cm  
BARRE RENFORT MUR-VERRE: 50 cm  
FIXING BAR WALL-GLASS: 50 cm  
BARRA RINFORZO PARETE-VETRO 50 cm

## COTEK - OUTLET

HERRAJES PARA DUCHAS - ACCESSOIRES DE DOUCHE  
SCHOWER GLASS FITTINGS - ACCESSORI PER DOCCIA

CR. BRILLO	CR. MATE	NEGRO	INOX BR
CR. POLI	CR. M	NOIR	INOX POLI
BR. CHR	M. CHR	BLACK	P.S.S.
CR. LUC.	CR. OPAC	NERO	INOX LUC
32	31	0N	22

## BILBAO - REFORZADA 27 KG 8/10



BISAGRA DESPLAZADA PARED-VIDRIO  
CHARNIÈRE MUR-VERRE DESPLACÉE  
HINGE WALL-GLASS OFFSET  
CERNIERA PARETE-VERRO ALA SPOSTATA  
\*4212/R32 latón eje reforzado

Cu		90x55 mm	€/u
	8-10 mm	27 kg/u	0°-90°-180°

ANGLE AXE RÉGLABLE  
ADJUSTABLE AXIS ANGLE  
ANGOLO ASSE REGOLABILE



BISAGRA DESPLAZADA PARED-VIDRIO  
CHARNIÈRE MUR-VERRE DESPLACÉE  
HINGE WALL-GLASS OFFSET  
CERNIERA PARETE-VERRO ALA SPOSTATA  
\*4212/032 latón eje reforzado  
\*4212/031 latón eje reforzado

Cu		90x55 mm	€/u
	8-10 mm	27 kg/u	0°-90°-180°



BISAGRA VIDRIO-VIDRIO 180°  
CHARNIÈRE VERRE-VERRE 180°  
HINGE GLASS-GLASS 180°  
CERNIERA VETRO-VETRO 180°  
\*4213/032 latón eje reforzado

Cu		115x90 mm	€/u
	8-10 mm	27 kg/u	0°-90°-180°

## \*ALICANTE 8/10



BISAGRA VIDRIO-VIDRIO 180°  
CHARNIÈRE VERRE-VERRE 180°  
HINGE GLASS-GLASS 180°  
CERNIERA VETRO-VETRO 180°  
\*4406/032 zamak

Zn		90x115 mm	€/u
	8-10 mm	20 kg/u	0°-90°-180°

## HERRAJE FIJO BISELADO



HERRAJE FIJO 90° PARED-VIDRIO  
FIXATION MUR-VERRE 90°  
BRACKET WALL-GLASS 90°  
MORSETTO PARETE-VERRO 90°  
\*4407/032 zamak

Zn		90x55 mm	€/u
	8-10 mm	2x Ø 16 mm	

## CIERRE PARA LAVABOS CON MANILLA



CERRADURA WC  
PESTILLO + INDICADOR  
SERRURE WC  
LOCK FOR WC  
SERRATURA WC  
\*4134/022

Al	inox s.s.	8-12mm	€/u
	Ø 2x42 mm		



CONTRACERRADURA VIDRIO  
GAÛCHE VERRE  
GLASS STRIKE PLATE  
CONTROSERRATURA VETRO  
\*4134/V22

Al		8-12 mm	€/u
	Ø 2x12 mm		



CONTRACERRADURA PARED  
GAÛCHE MUR  
WALL STRIKE PLATE  
CONTROSERRATURA PARETE  
\*4134/P22

inox s.s.	∞	4134	€/u
-----------	---	------	-----

## COTEK - OUTLET

HERRAJES PARA DUCHAS - ACCESSOIRES DE DOUCHE  
SCHOWER GLASS FITTINGS - ACCESSORI PER DOCCIA

CR. BRILLO	CR. MATE	INOX BR	INOX SAT
CR. POLI	CR. M	INOX POLI	INOX SAT
BR. CHR	M. CHR	P.S.S.	S.S.S.
CR. LUC.	CR. OPAC	INOX LUC	INOX SAT
32	31	22	28

## BARRAS REFUERZO



BARRA REFUERZO VIDRIO-VIDRIO 45°  
BARRÉ RENFORT VERRE-VERRE 45°  
FIXING BAR GLASS-GLASS 45°  
BARRA RINFORZO VETRO-VETRO 45°  
\*4161/032 "U LATÓN"

Cu	inox s.s.	6-10 mm	€/u
	L	850-1050 m	

## ACCESORIOS BAÑO



TOALLERO HORIZONTAL  
SUPPORT SERVIETTE DE BAIN  
SINGLE TOWEL RAIL  
PORTA ASCIUGAMANO  
A PARETE  
\*4950/032

Al	50 cm	€/u
----	-------	-----



PORTAROLLOS  
SUPPORT DE ROULEAU TOILETTE  
TOILET PAPER HOLDER  
PORTAROTOLO CARTA IGIENICA  
\*4952/032

Al		€/u
----	--	-----



MANILLA + POMO  
POIGNÉE + BOUTON  
DOOR PULL + KNOB  
MANIGLIA + POMOLO  
\*4979/022

inox s.s.	6-10 mm	205x25	€/u
	2 x Ø 9 mm	CC=190 mm	

## CERRADURAS Y MUESCAS



CERRADURA VIDRIO-PARED SIN MUESCA  
SERRURE VERRE-MUR SANS ENCOCHE  
GLASS-WALL LOCK WITHOUT CUT-OUT  
SERRATURA VETRO-PARETE SENZA TACCA  
\*4178/P22

inox s.s.		90x64	€/u
	10-12 mm		

## HERRAJES FIJOS



HERRAJE FIJO 90° PARED-VIDRIO  
FIXATION MUR-VERRE 90°  
BRACKET WALL-GLASS 90°  
MORSETTO PARETE-VERRO 90°  
\*4412/032

Cu		50x50 mm	€/u
	6-8 mm	2x Ø 14 mm	



HERRAJE FIJO 90° PARED-VIDRIO  
FIXATION MUR-VERRE 90°  
BRACKET WALL-GLASS 90°  
MORSETTO PARETE-VERRO 90°  
\*4417/032

Cu		90x55 mm	€/u
	8-10 mm	2x Ø 16 mm	



HERRAJE FIJO 90° PARED-VIDRIO  
FIXATION MUR-VERRE 90°  
BRACKET WALL-GLASS 90°  
MORSETTO PARETE-VERRO 90°  
\*4192/032

Cu		50x45 mm	€/u
	6-8 mm	Ø 14 mm	



HERRAJE FIJO 90° VIDRIO-VIDRIO  
FIXATION VERRE-VERRE 90°  
BRACKET GLASS-GLASS 90°  
MORSETTO VETRO-VETRO 90°  
\*4189/032

Cu		50x45 mm	€/u
	6-8 mm	Ø 14 mm	



# COTEK - APIL-PLUS\*

PUERTAS CORREDERAS APILABLES EN PARKING  
 SYSTEME DE PORTE EMPILABLE AVEC PARKING  
 SLIDING FOLDING DOOR SYSTEM WITH PARKING  
 PORTE SCORREVOLI A PARCHEGGIO

CR. BRILLO	PL. MATE	INOX BR	INOX SAT
CH. POLI	ANOD. M	INOX POLI	INOX SAT
BR. CHR	AN. CHR	P. S. S.	S. S. S.
CR. LUC.	AN. OPAC	INOX LUC	INOX SAT
<b>32</b>	<b>01</b>	<b>22</b>	<b>28</b>

# COTEK - APIL-PLUS\*

PUERTAS CORREDERAS APILABLES EN PARKING  
 SYSTEME DE PORTE EMPILABLE AVEC PARKING  
 SLIDING FOLDING DOOR SYSTEM WITH PARKING  
 PORTE SCORREVOLI A PARCHEGGIO

CR. BRILLO	PL. MATE	INOX BR	INOX SAT
CH. POLI	ANOD. M	INOX POLI	INOX SAT
BR. CHR	AN. CHR	P. S. S.	S. S. S.
CR. LUC.	AN. OPAC	INOX LUC	INOX SAT
<b>32</b>	<b>01</b>	<b>22</b>	<b>28</b>

## APIL-PLUS\*

Puertas correderas apilables en parking para vidrio templado

Aluminio anodizado y acero INOX  
 Peso max: 100 kg/hoja  
 Vidrio: 10-12 mm  
 Alto max. hoja: 3,5 m (12 mm)

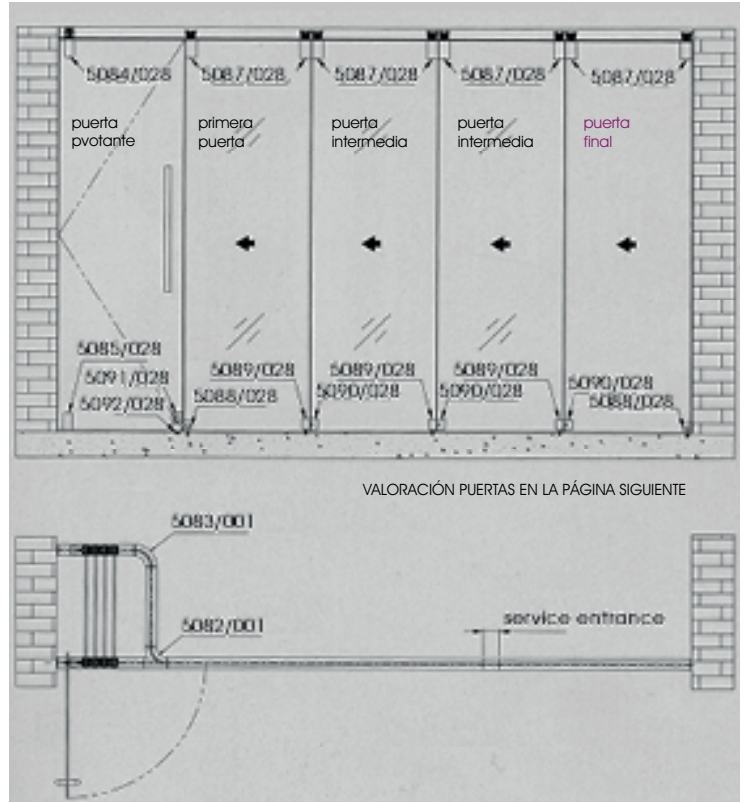

	<b>GUÍA SUPERIOR</b> COULISSE HAUTE UPPER TRACK GUIDA SUPERIOR *5080/101	Al	5 m	€/m	<input type="checkbox"/>	<input type="checkbox"/>	<input type="checkbox"/>	<input type="checkbox"/>	<input type="checkbox"/>
	<b>ENTRADA PARKING 90°</b> ENTRÉE DU PARKING 90° PARKING ENTRANCE 90° ENTRATA PARCHEGGIO 90° *5081/001 derecha *5082/001 izquierda	Al		€/u	<input type="checkbox"/>	<input type="checkbox"/>	<input type="checkbox"/>	<input type="checkbox"/>	<input type="checkbox"/>
	<b>GUÍA SUPERIOR CURVA 90°</b> COULISSE HAUTE COURBE 90° BEND UPPER TRACK 90° GUIDA SUPERIORE CURVA 90° *5083/001	Al		€/u	<input type="checkbox"/>	<input type="checkbox"/>	<input type="checkbox"/>	<input type="checkbox"/>	<input type="checkbox"/>
	<b>HERRAJE SUPERIOR</b> PENTURE HAUTE TOP PIVOTING HINGE CERNIERA SUPERIORE PIVOTANTE *5084/022	inox s.s.		10-12mm	€/u	<input type="checkbox"/>	<input type="checkbox"/>	<input type="checkbox"/>	<input type="checkbox"/>
	<b>HERRAJE INFERIOR</b> PENTURE BASSE BOTTOM PIVOT HINGE CERNIERA INFERIORE PIVOTANTE *5085/022 leva alemana broches aleman, German pin, perno tedesco	inox s.s.		10-12mm	€/u	<input type="checkbox"/>	<input type="checkbox"/>	<input type="checkbox"/>	<input type="checkbox"/>
	<b>GIRO INFERIOR LEVA ALEMANA</b> CRAPAUDINE BASSE BROCHES GER. FLOOR PIVOT GERMAN PIN GIRO INFERIORE PERNO TEDESCO *5086/022	inox s.s.			€/u	<input type="checkbox"/>	<input type="checkbox"/>	<input type="checkbox"/>	<input type="checkbox"/>
	<b>COJINETE SUPERIOR</b> GALET SUPERIEUR UPPER ROLLER PATTINO SCORREVOLE SUPERIORE *5087/022	inox s.s.		10-12mm	€/u	<input type="checkbox"/>	<input type="checkbox"/>	<input type="checkbox"/>	<input type="checkbox"/>
	<b>PESTILLO INFERIOR CIERRE FRONTAL</b> VERROU INFÉRIEUR BOTTOM BOLT CHIAVISTELLO INFERIORE *5088/022	inox s.s.		10-12mm	€/u	<input type="checkbox"/>	<input type="checkbox"/>	<input type="checkbox"/>	<input type="checkbox"/>
	<b>PESTILLO INFERIOR CIERRE LATERAL</b> VERROU INFÉRIEUR BOTTOM BOLT CHIAVISTELLO INFERIORE *5089/022	inox s.s.		10-12mm	€/u	<input type="checkbox"/>	<input type="checkbox"/>	<input type="checkbox"/>	<input type="checkbox"/>
	<b>CONTRAPESTILLO</b> VERROU INFÉRIEUR BOTTOM BOLT CHIAVISTELLO INFERIORE *5090/022	inox s.s.		10-12mm	€/u	<input type="checkbox"/>	<input type="checkbox"/>	<input type="checkbox"/>	<input type="checkbox"/>
	<b>CERRADURA DISTINTA LLAVE</b> SERRURE COMBINAISONS DIFFÉRENTES LOCK DIFFERENT KEYED SERRATURA COMBINAZIONI DISTINTE *5091/022	inox s.s.		10-12mm	€/u	<input type="checkbox"/>	<input type="checkbox"/>	<input type="checkbox"/>	<input type="checkbox"/>
	<b>CONTRAPESTILLO</b> VERROU INFÉRIEUR BOTTOM BOLT CHIAVISTELLO INFERIOR *5092/022	inox s.s.		10-12mm	€/u	<input type="checkbox"/>	<input type="checkbox"/>	<input type="checkbox"/>	<input type="checkbox"/>



# COTEK - APIL-PLUS\*

PUERTAS CORREDERAS APILABLES EN PARKING  
SYSTEME DE PORTE EMPILABLE AVEC PARKING  
SLIDING FOLDING DOOR SYSTEM WITH PARKING  
PORTE SCORREVOLI A PARCHEGGIO

CR. BRILLO	PL. MATE	INOX BR	INOX SAT
32	01	22	28

# COTEK - APIL-PLUS\*

PUERTAS CORREDERAS APILABLES EN PARKING  
SYSTEME DE PORTE EMPILABLE AVEC PARKING  
SLIDING FOLDING DOOR SYSTEM WITH PARKING  
PORTE SCORREVOLI A PARCHEGGIO

CR. BRILLO	PL. MATE	INOX BR	INOX SAT
32	01	22	28

## CALCULO PRECIO PUERTAS

- 1 puerta pivotante (tirador no incluido)
- 1 primera puerta
- 1 puerta final
- X puertas intermedias en función del hueco

Ejemplo: hueco: 4 m y 4 puertas  
(1 pivotante + 3 corederas que tienen el mismo precio)

1 x 5095/022: 180 x 1 = 180  
 1 x 5096/022: }  
 1 x 5097/022: } 320 x 3 = 960  
 1 x 5098/022: }  
 total = 1140

Ejemplo: hueco: 10 m y 10 puertas  
(1 pivotante + 9 corederas que tienen el mismo precio)

1 x 5095/022: 180 x 1 = 180  
 1 x 5096/022: }  
 7 x 5097/022: } 320 x 9 = 2880  
 1 x 5097/022: }  
 total = 3060

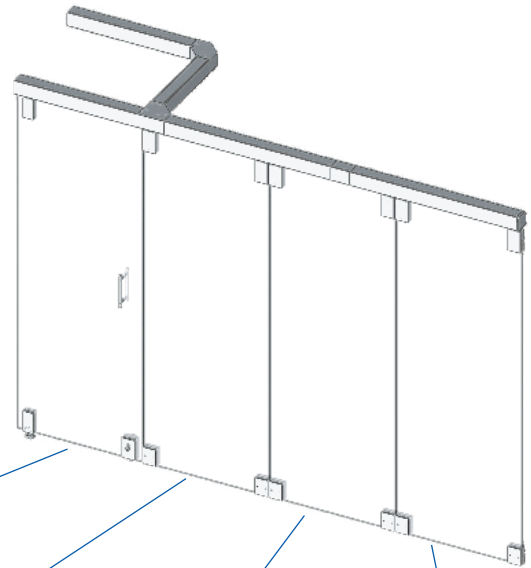

**PUERTA PIVOTANTE**  
VERROU INFÉRIEUR  
BOTTOM BOLT  
CHIAVISTELLO INFERIORE  
5084 X 1  
5085 X 1  
5086 X 1  
5091 X 1  
5092 X 1  
\*5095/022      o €/u

**PRIMERA PUERTA**  
VERROU INFÉRIEUR  
BOTTOM BOLT  
CHIAVISTELLO INFERIORE  
5087 X 2  
5088 X 1  
5089 X 1  
\*5096/022      o €/u

**PUERTA INTERMEDIA**  
VERROU INFÉRIEUR  
BOTTOM BOLT  
CHIAVISTELLO INFERIORE  
5087 X 2  
5089 X 1  
5090 X 1  
\*5097/022      o €/u

**PUERTA INTERMEDIA**  
VERROU INFÉRIEUR  
BOTTOM BOLT  
CHIAVISTELLO INFERIORE  
5087 X 2  
5088 X 1  
5090 X 1  
\*5098/022      o €/u

## CALCULO PRECIO CARRIL

medida hueco + 1 m x precio €/ml carril  
curva 90° x precio curva  
entrada parking (der/izq)

Ejemplo: hueco: 4 m y 4 puertas (1 pivotante + 3 corederas)

carril 5080/101: 5 x 75 = 375  
curva 90° 5083/001: 1 x 155  
entrada parking: 5082/001: 1 x 240  
Total carril = 770

Ejemplo: hueco: 10 m y 10 puertas (1 pivotante + 9 corederas)

carril 5080/101: 11 x 75 = 825  
curva 90° 5083/001: 1 x 155  
entrada parking: 5082/001: 1 x 240  
Total carril = 1220

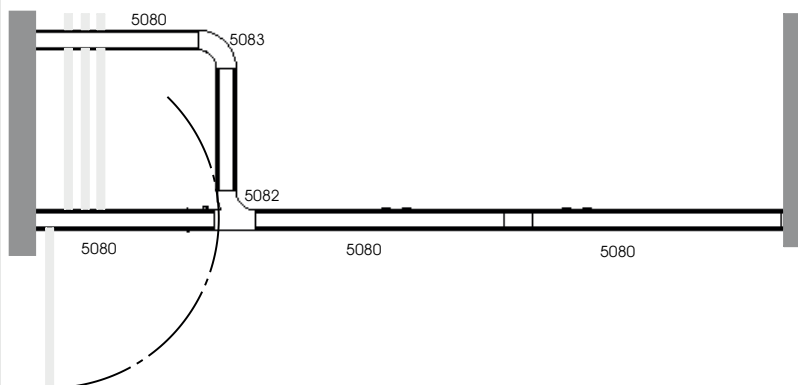

# COTEK - SMART LOCK

CERRADURAS PUERTAS CORREDERA - SERRURES PORTES COULISSANTS  
SLIDING DOORS LOCKS - SERRATURE PORTE SCORREVOLI

PLASTIQUE  
PLASTIC  
PLASTICA

09

## CERRADURAS DIGITALES

Nueva cerradura inteligente SMARTLOCK para puertas batientes vidrio/vidrio sin muesca en el vidrio

Sistema de desbloqueo con

1. huella dactilar (hasta 300 registros)
  2. password numérico (hasta 300 registros)
  3. mando a distancia
  4. personalizable con tarjeta de crédito
- Algoritmo de huella digital líder internacionalmente, estable y seguro con de doble autenticación de seguridad.
  - Lectura del voltaje de la batería en tiempo real y aviso para su sustitución.
  - Temperatura: de -25° a 65°. Humedad: 0-95%.
  - Evitar exponerla directamente a la lluvia.



PLA  €/u

**CERRADURA CON PASSWORD / STANDARD**  
SERRURE AVEC MOT DE PASSE / STANDARD  
LOCK WITH PASSWORD / STANDARD  
SERRATURA CON PASSWORD / STANDARD

**CERRADURA SIN MUESCA**  
SERRURE SANS ENCOCHE  
LOCK WITHOUT CUT-OUT  
SERRATURA SENZA TACCA

\*4288/009

o

# COTEK - PIVOTEK

INOX BR	INOX SAT	ZINCADO
INOX POLI	INOX SAT	PL. ZINC
P.S.S.	S.S.S.	ZINC PL.
INOX LUC	INOX SAT	ZINCATO
22	28	34

inox s.s.	10-12mm	€/u
	∅ 26 mm	∇ ∅ 32 mm

o

**GIRO SUPERIOR VIDRIO FIJO**  
SUPPORT HAUTE VERRRE FIXE+PIVOT  
FIXED GLASS UPPER SUPPORT+PIVOT  
SUPPORTO A VETRO FISSO+GIRO SUP

\*4391/028



**GIRO SUPERIOR PARED Y VIDRIO FIJO**  
SUPPORT HAUTE VERRRE FIXE ET MUR  
+PIVOT  
FIXED GLASS AND WALL UPPER  
SUPPORT+PIVOT  
SUPPORTO A VETRO FISSO E  
PARETE+GIRO SUP

\*4392/028



**GIRO SUPERIOR 2 VIDRIOS FIJOS**  
SUPPORT HAUTE 2 VERRRES FIXES+PIVOT  
2 FIXED GLASSES UPPER SUPPORT+PIVOT  
SUPPORTO 2 VETRI FISSI+GIRO SUP

\*4393/028

inox s.s.	10-12mm	€/u
	∅ 26 mm	∇ ∅ 32 mm

o

inox s.s.	10-12mm	€/u
	∅ 26 mm	∇ ∅ 32 mm

o

**GIRO INFERIOR LEVA ITALIANA**  
CRAPAUDINE BASSE BROCHES ITAL  
FLOOR PIVOT ITALIAN PIN  
GIRO INFERIORE PERNO ITALIANO

4396/028



**GIRO SUPERIOR 2 VIDRIOS FIJOS**  
SUPPORT HAUTE 2 VERRRES FIXES  
2 FIXED GLASSES UPPER SUPPORT  
SUPPORTO 2 VETRI FISSI

\*4397/028

inox s.s.	16x16	€/u

o

inox s.s.	10-12mm	€/u
	∅ 26 mm	∇ ∅ 32 mm

o

**LLAVE REGULABLE x TORNILLO**  
OUTIL RÉGLABLE x VIS  
ADJUSTABLE TOOL x SCREWS  
UTENSILE REGOLABILE x VITI

4398/034



o

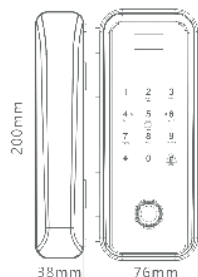
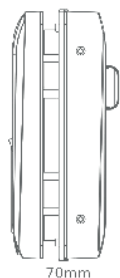
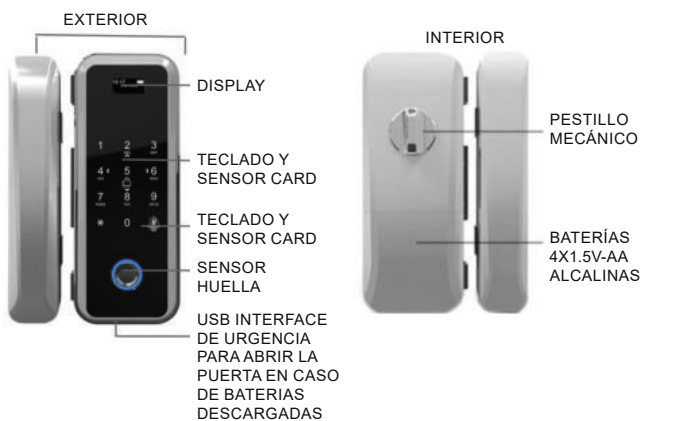

# COTEK - OUTLET

PUERTAS CORREDERA - PORTES COULISSANTS  
SLIDING DOORS - PORTE SCORREVOLI

CR. BRILLO	CR. MATE	INOX BR	INOX SAT
CHR. POLI	CHR. M	INOX POLI	INOX SAT
BR. CHR	M. CHR	P. S. S.	S. S. S.
CR. LUC.	CR. OPAC	INOX LUC	INOX SAT
<b>32</b>	<b>31</b>	<b>22</b>	<b>28</b>

## BISAGRA PIVOTANTE AUTOMÁTICA

Retención a 0°

Fuerza cierre ajustable  
Para uso interior

STOP A 0°  
ADJUSTABLE CLOSING FORCE  
FOR INDOOR USE

ARRÊTER À 0°  
FORCE DE FERMETURE RÉGLABLE  
POUR UTILISATION EN INTÉRIEUR

STOP A 0°  
FORZA DI CHIUSURA REGOLABILE  
PER USO INTERNO



BISAGRA AUTOMÁTICA PIVOTANTE  
CHARNIÈRE AUTOMATIQUE PIVOTANT  
PIVOTING AUTOMATIC HINGE  
CERNIERA AUTOMATICA PIVOTANTE

inox s.s.	Al		180x65	€/u
	10-12 mm	60 kg	0°-360°	
<-> max. 900 mm				

JUEGOS DE 2 UNIDADES  
JEUX DE 2 UNITÉS  
SET 2 PIÈCES  
SET 2 PEZZI

\*1551/0.. sup.  
\*1550/0.. inf.

\*o \*o  
o o

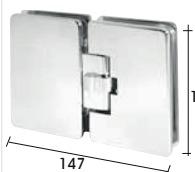

BISAGRA VIDRIO-VIDRIO 180°  
CHARNIÈRE VERRE-VERRE 180°  
HINGE GLASS-GLASS 180°  
CERNIERA VETRO-VETRO 180°

\*4151/031 latón

Cu		147x100 mm	€/u
	8-12 mm	25 kg/u	0°-90°-180°

o

DERECHA

SOPORTE CRISTAL ESQUINERO  
PINSE ANGULAIRES VERRE  
CORNER CLAMP GLASS  
MORSETTO ANGOLARE VETRO  
INOX 316.  
se vende EN KIT 2 unidades  
kits vendus dans 2 unités  
sold in kits 2 units  
Si vende in kits di 2 unità

\*1406/022 der. 8 mm  
droite/right/destra

\*1408/022 izq. 8 mm  
gauche/left/sinistra

\*1432/022 der. 10 mm  
droite/right/destra

\*1433/022 izq. 10 mm  
gauche/left/sinistra

\*o \*o  
\*o \*o



HERRAJE FIJO 90° VIDRIO-VIDRIO  
FIXATION VERRE-VERRE 90°  
BRACKET GLASS-GLASS 90°  
MORSETTO VETRO-VETRO 90°

\*4318/028

inox s.s.		2 x Ø 12 mm	€/u
	6-10 mm	95x95 mm	

o

IZQUIERDA

SOPORTE BARANDILLA  
SUPPORT GARDE-CORPS  
SUPPORT BALUSTRADE  
SUPPORTO BALAUSTRAS  
INOX 316  
1447/022 16 mm



inox s.s.	Ø 48 mm	Ø 16 mm	€/u
	16 mm		

o



"L" INOX PULIDO  
L INOX POLI  
L POL. STAINLESS STEEL  
L INOX LUCIDO

\*4372/122 15x15x1 mm

\*4373/122 20x20x1 mm

\*4374/122 25x25x1 mm

inox s.s.		L 3 m	€/m
-----------	--	-------	-----

\*o \*o  
o



CONEXIÓN 90° CARRIL  
FIXATION COULISSE 90°  
TRACKS CONNEXION 90°  
CONNESIONE GUIDE 90°

\*4365/028

inox s.s.	Ø 25	∞ 4350	€/u
-----------	------	--------	-----

o

STOP COJINETE  
STOP CHARLOT  
STOP ROLLER  
STOP CUSCINETTO

\*4366/028

inox s.s.	Ø 25	∞ 4365	€/u
-----------	------	--------	-----

o

# COTEK - OUTLET

PUERTAS CORREDERA - PORTES COULISSANTS  
SLIDING DOORS - PORTE SCORREVOLI

CR. BRILLO	PL. MATE	INOX BR	INOX SAT
CHR. POLI	ANOD. M	INOX POLI	INOX SAT
BR. CHR	AN. CHR	P. S. S.	S. S. S.
CR. LUC.	AN. OPAC	INOX LUC	INOX SAT
<b>32</b>	<b>01</b>	<b>22</b>	<b>28</b>



SOPORTE CRISTAL PARA TUBO  
PINCE VERRE POUR TUBE  
GLASS CLAMP FOR TUBE  
MORSETTO VETRO PER TUBO  
\*1416/031  
\*1416/034

Zn		6-10 mm	Ø 38-42	€/u



SOPORTE CRISTAL PARA TUBO  
PINCE VERRE POUR TUBE  
GLASS CLAMP FOR TUBE  
MORSETTO VETRO PER TUBO  
\*1421/0.. 10mm

inox s.s.		10 mm	Ø 38-42	€/u



SOPORTE CRISTAL ESQUINERO  
PINSE ANGULAIRES VERRE  
CORNER CLAMP GLASS  
MORSETTO ANGOLARE VETRO  
INOX 316.  
se vende EN KIT 2 unidades  
kits vendus dans 2 unités  
sold in kits 2 units  
Si vende in kits di 2 unità

inox s.s.		8 ó 10 mm	60x60	€/u

\*1406/022 der. 8 mm  
droite/right/destra

\*1408/022 izq. 8 mm  
gauche/left/sinistra

\*1432/022 der. 10 mm  
droite/right/destra

\*1433/022 izq. 10 mm  
gauche/left/sinistra

\*o \*o  
\*o \*o

SOPORTE BARANDILLA  
SUPPORT GARDE-CORPS  
SUPPORT BALUSTRADE  
SUPPORTO BALAUSTRAS  
INOX 316  
1447/022 16 mm



inox s.s.	Ø 48 mm	Ø 16 mm	€/u
	16 mm		

o

# COTEK - OUTLET

HERRAJES PARA PUERTAS - QUINCAILLERIE DE PORTE  
DOORS PATCH FITTINGS - ACCESSORI PER PORTE

CR. BRILLO C-PR. POLI BR. CH-R CR. ILLC.	INOX BR INOX POLI P.S.S. INOX ILLC.	INOX SAT INOX SAT S.S.S. INOX SAT	32	22	28
---	--	--	----	----	----

Cu	6-12 mm	Ø25	€/u
2xØ10 mm CC=305 mm			

\*o

inox s.s.	6-12 mm	Ø19	€/u
2xØ10 mm CC=450 mm			

\*o

inox s.s.	6-10 mm	205x25	€/u
2 x Ø 9 mm CC=190 mm			

o



MANILLA DOBLE  
POIGNÉE DOUBLE  
DOUBLE DOOR PULL  
MANIGLIA DOPPIA  
**\*4125/032**

C-C=305 mm



MANILLA DOBLE  
POIGNÉE DOUBLE  
DOUBLE DOOR PULL  
MANIGLIA DOPPIA  
**\*4126/0E2**

C-C=450 mm

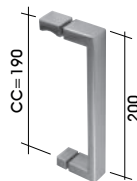

MANILLA + POMO  
POIGNÉE + BOUTON  
DOOR PULL + KNOB  
MANIGLIA + POMOLO  
**\*4979/022**

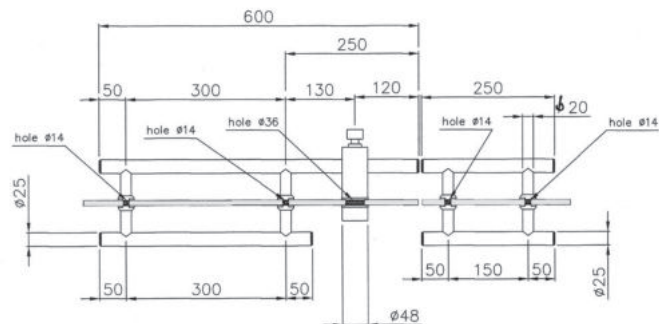

inox s.s.	10-12 mm	Ø 25	€/u
2xØ14 mm 1xØ36 mm			

\*o

\*o

MANILLA HORIZONTAL  
± CERRADURA Y PESTILLO  
POIGNÉE DOUBLE HORIZ.  
+ SERRURE AND VERROU  
HORIZ. DOUBLE HANDLE  
+ LOCK AND BOLT  
MANIGLIONE ORIZZ.  
+ SERRATURA E CHIAVISTELLO  
**\*4495/0..**

MANILLA HORIZONTAL  
± CONTRACERRADURA  
POIGNÉE DOUBLE HORIZ. + GAÛCHE  
HORIZ. DOUBLE HANDLE + STRIKE PLATE  
MANIGLIONE ORIZZ. + CONTRASERR.  
**\*4496/022**

\*o

# COTEK - OUTLET

HERRAJES PARA PUERTAS - QUINCAILLERIE DE PORTE  
DOORS PATCH FITTINGS - ACCESSORI PER PORTE

INOX BR INOX POLI P.S.S. INOX ILLC.	INOX SAT INOX SAT S.S.S. INOX SAT	22	28
--	--	----	----

## MINI CRUZETAS - MINI SPIDER

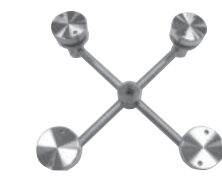

ANCLAJE 4 VIDRIOS USO INTERIOR  
SPIDER 4 VOIES USAGE INTERIEUR  
SPIDER 4 WAYS FOR INDOOR USE  
SPIDER 4 VIE USO INTERNO  
**\*1460/028**

inox s.s.	100x100	€/u
Ø12 mm 8-12 mm		

o



ANCLAJE 2 VIDRIOS 45° USO INTERIOR  
SPIDER 2 VOIES USAGE INTERIEUR  
SPIDER 2 WAYS FOR INDOOR USE  
SPIDER 2 VIE 45° USO INTERNO  
**\*1461/028**

inox s.s.	100x50	€/u
Ø12 mm 8-12 mm		

o



ANCLAJE 2 VIDRIOS 180° USO INTERIOR  
SPIDER 2 VOIES 180° USAGE INTERIEUR  
SPIDER 2 WAYS 180° FOR INDOOR USE  
SPIDER 2 VIE 180° USO INTERNO  
**\*1462/028**

inox s.s.	100 mm	€/u
Ø12 mm 8-12 mm		

o



ANCLAJE 1 VIDRIO 45° USO INTERIOR  
SPIDER 1 VIE USAGE INTERIEUR  
SPIDER 1 WAY 45° FOR INDOOR USE  
SPIDER 1 VIA 45° USO INTERNO  
**\*1463/028**

inox s.s.	50x50	€/u
Ø12 mm 8-12 mm		

o

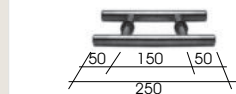
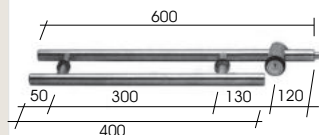
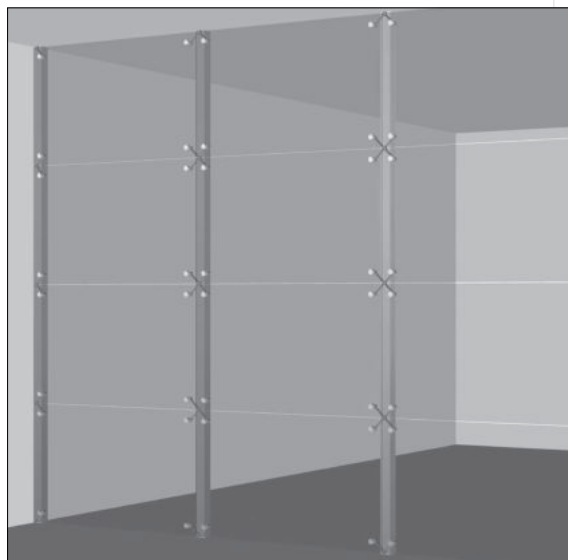

# COTEK - OUTLET

BARANDILLAS DE VIDRIO - GARDE-CORPS DE VERRE  
GLASS BALUSTRADES - BALAUSTRÉ DI VETRO

INOX SAT	AN. INOX	BRUTO
INOX SAT	AN. INOX	BRUT
S.S.S.	AN. SS	RAW
INOX SAT	AN. INOX	GREZZO
28	08	00

## DELPHOS

BARANDILLAS DE VIDRIO  
garde-corps en verre  
glass balustrades  
balaustre in vetro

Vidrio laminado y templado  
Verre feuilleté et trempé  
Laminated and tempered glass  
Vetro laminato e temperato  
6+6+2 mm (12,76 mm)  
8+8+2 mm (16,76 mm)  
10+10+2 mm (20,76 mm)

### VIDRIO 10+10

ALTURA MAX VIDRIO: 1200 mm  
Hauteur max. verre: 1200 mm  
Height max. glass: 1200 mm  
Altezza mass. vetro: 1200 mm

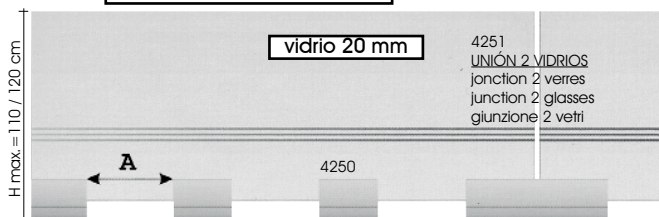

A = espacio entre soportes =  
distance entre pincas  
distance between clamps  
distanza fra morsetti

30-35 cm (H max. = 1200 mm)
35-40 cm (H max. = 1100 mm)
40-45 cm (H max. = 1000 mm)
45-50 cm (H max. = 900 mm)
50-55 cm (H max. = 800 mm)
55-65 cm (H max. = 700 mm)
65-80 cm (H max. = 600 mm)

## 20 MM (10+10)

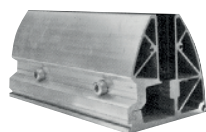

PINZA SUELO-VIDRIO 20 CM  
PINCE SOL-VERRE 20 CM  
CLAMP FLOOR-GLASS 20 CM  
PINZA SUOLO-VETRO 20 CM  
\*4250/000

Al	200x140x120 mm	€/u
∞ 4252	10+10+2mm	

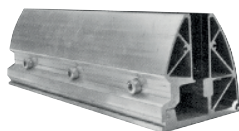

PINZA SUELO-VIDRIO 40 CM  
PINCE SOL-VERRE 40 CM  
CLAMP FLOOR-GLASS 40 CM  
PINZA SUOLO-VETRO 40 CM  
\*4251/000

Al	400x140x120 mm	€/u
∞ 4252	10+10+2mm	



ANCLAJE M12-180 mm  
ANCHORAGE M12-180 mm  
ANCORAGGIO M12-180 mm  
\*4237/180

Fe	galvaniz.	€/u
----	-----------	-----

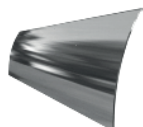

PERFIL TAPA  
PROFIL COUVERTURE  
COVER PROFIL  
PROFILO COPERTINA  
\*4252/108

Al	6/3 m	h.140	€/m
∞ 4251-4252			



REMATE FINAL  
BOUCHON  
END-CAP  
COPRITESTA  
\*4253/028

inox s.s.	∞ 4250-4251-4252	€/u
-----------	------------------	-----



REMATE INTERMÉDIO  
BOUCHON INTERMÉDIAIRE  
INTERMEDIATE END-CAP  
COPRITESTA INTERMÉDIO  
\*4254/028

inox s.s.	∞ 4250-4251-4252	€/u
-----------	------------------	-----

# COTEK - OUTLET

BARANDILLAS DE VIDRIO - GARDE-CORPS DE VERRE  
GLASS BALUSTRADES - BALAUSTRÉ DI VETRO

INOX SAT	AN. INOX	BRUTO
INOX SAT	AN. INOX	BRUT
S.S.S.	AN. SS	RAW
INOX SAT	AN. INOX	GREZZO
28	08	00

### VIDRIO 8+8

ALTURA MAX VIDRIO: 1000 mm  
Hauteur max. verre: 1000 mm  
Height max. glass: 1000 mm  
Altezza mass. vetro: 1000 mm

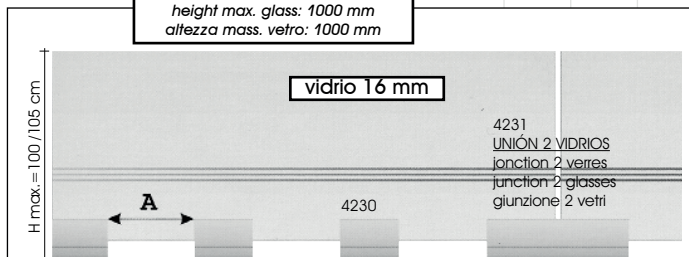

A = espacio entre soportes =  
distance entre pincas  
distance between clamps  
distanza fra morsetti

25-30 cm (altura vidrio barandilla 1000 mm)
30-35 cm (altura vidrio barandilla 900 mm)
35-40 cm (altura vidrio barandilla 800 mm)
40-45 cm (altura barandilla 700 mm)

## 16 MM (8+8)



PINZA SUELO-VIDRIO 30 CM  
PINCE SOL-VERRE 30 CM  
CLAMP FLOOR-GLASS 30 CM  
PINZA SUOLO-VETRO 30 CM  
\*4230/000

Al	300 (200) x 100 x 100	€/u
∞ 4232	8+8+2 mm	



PINZA SUELO-VIDRIO 40 CM  
PINCE SOL-VERRE 40 CM  
CLAMP FLOOR-GLASS 40 CM  
PINZA SUOLO-VETRO 40 CM  
\*4231/000

Al	400 (300) x 100 x 100	€/u
∞ 4232	8+8+2 mm	



ANCLAJE M10-120 mm  
ANCHORAGE M10-120 mm  
ANCORAGGIO M10-120 mm  
\*4237/120

Fe	galvaniz.	€/u
----	-----------	-----

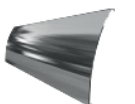

PERFIL TAPA  
PROFIL COUVERTURE  
COVER PROFIL  
PROFILO COPERTINA  
\*4232/108

Al	6/3 m	h.100	€/m
∞ 4230-4231			



REMATE FINAL  
BOUCHON  
END-CAP  
COPRITESTA  
\*4233/028

inox s.s.	∞ 4230-4231-4232	€/u
-----------	------------------	-----



REMATE INTERMÉDIO  
BOUCHON INTERMÉDIAIRE  
INTERMEDIATE END-CAP  
COPRITESTA INTERMÉDIO  
\*4236/028

inox s.s.	∞ 4230-4231-4232	€/u
-----------	------------------	-----



PERFIL TAPA CUADRADA  
PROFIL COUVERTURE  
COVER PROFIL  
PROFILO COPERTINA  
\*4238/108

Al	6/3 m	92x49	€/m
∞ 4230-4231			



REMATE FINAL  
BOUCHON  
END-CAP  
COPRITESTA  
\*4239/028

inox s.s.	∞ 4230-4231-4232	€/u
-----------	------------------	-----



REMATE INTERMÉDIO  
BOUCHON INTERMÉDIAIRE  
INTERMEDIATE END-CAP  
COPRITESTA INTERMÉDIO  
\*4240/028

inox s.s.	∞ 4230-4231-4232	€/u
-----------	------------------	-----

## PASAMANO MAIN CURRANTE-HANDRAIL-CORRIMANO



PASAMANO REDONDO  
MAIN COURANTE RONDE  
HANDRAIL ROUND PROFILE  
CORRIMANO ROTONDO  
\*4234/108

Al	6/3 m	Ø60	€/m
∞ 16-22mm			

## PRECIOS

LOS PRECIOS DE ESTA TARIFA SON P.V.P.  
(PRECIOS DE VENTA AL PÚBLICO RECOMENDADOS)

LOS PRECIOS NETOS DE FACTURACIÓN SE CORRESPON-  
DERÁN A LOS PRECIOS PVP DE LA TARIFA MENOS EL  
DESCUENTO ASIGNADO:

**PVP menos:**

**DESCUENTO**

## CONDICIONES PORTES

Alusystem no se hace cargo de los retrasos o incidencias  
imputables a las agencias de transporte subcontratadas.

### PENÍNSULA Y BALEARES:

**CORTOS:** Los portes de los bultos inferiores a 2,5m de largos están pagados a partir de 150 eur netos de pedido. Por debajo de este importe se cargarán a tarifa según la tabla adjunta.

**LARGOS:** Los portes de los bultos más largos de 2,5 mts están pagados a partir de 350 eur de pedido, en Península y Baleares. Por debajo de este importe se cargarán a tarifa según la tabla adjunta.

**CANARIAS:** El transporte está pagado a partir de 350 eur de pedido independientemente del largo de los bultos y se realiza por barco.

**CEUTA Y MELILLA Y EXPORTACIÓN:** Consultar.

### LARGOS:

- Bultos más largos de 2,5 mts.  
Pedido mínimo para portes pagados:  
Península, Baleares y Canarias: 350 eur  
Andorra: 750 eur

### CORTOS:

- Paquetería y bultos de máx. 2,5 mts.  
Pedido mínimo para portes pagados:  
Península y Baleares: 150 eur

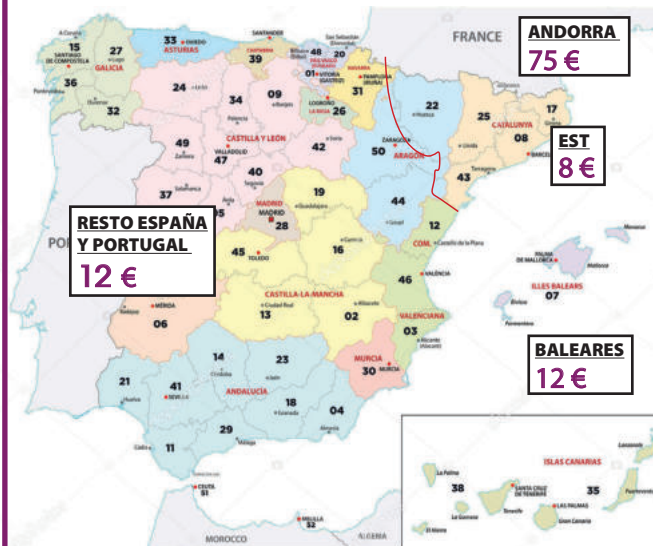
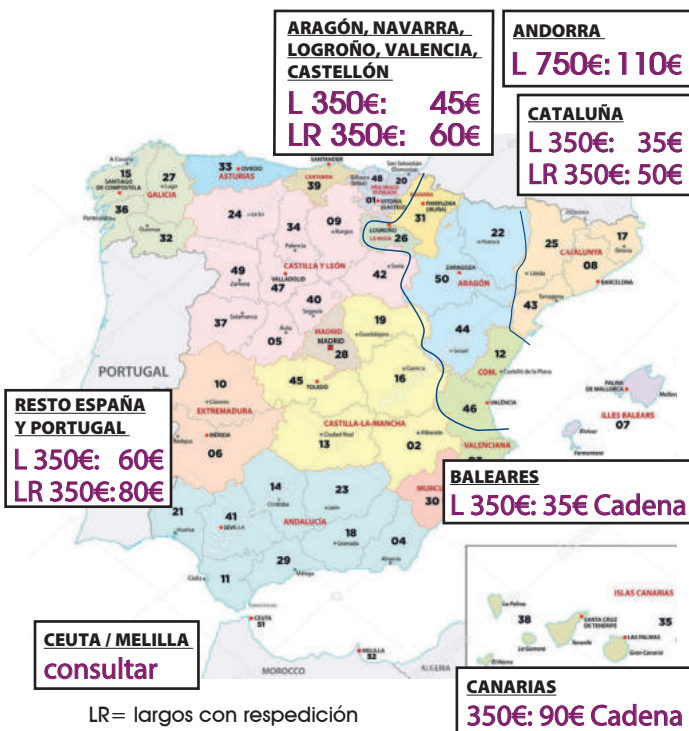

## CONDICIONES PAGO

Los pagos están asegurados por Crédito y Caucción. En caso que los clientes no tengan concedido el crédito por parte de CyC, el pago tendrá que hacerse por anticipado antes de la salida de la mercancía.

- Giro bancario
- Pagaré
- Transferencia

días a fecha factura



# CONDICIONES DE VENTAS

1. El comprador, al efectuar el pedido, acepta las condiciones de venta estipuladas por ALU-SYSTEM, S.A.U.

2. ALU-SYSTEM, S.A.U. se reserva el derecho de aceptar los pedidos del comprador, en función de la situación jurídica, solvencia y otras consideraciones comerciales que reuna éste.

3. Todas las ventas se entienden realizadas en el domicilio social de ALU-SYSTEM, S.A.U., y en el mismo, el comprador se hace cargo de los géneros adquiridos. Las mercancías viajan por cuenta y riesgo del comprador.

Por pacto entre ambas partes, ALU-SYSTEM, S.A.U. entregará los pedidos en el domicilio del comprador, mediante el transportista que ALU-SYSTEM, S.A.U. designe, en régimen de portes pagados. En función del importe mínimo que ALU-SYSTEM, S.A.U. establezca, se cargará el importe del transporte en la correspondiente factura.

Si por motivos de urgencia del comprador, los pedidos se tuvieran que enviar por transporte urgente o por otro medio de transporte distinto del designado por ALU-SYSTEM, S.A., la mercancía se remitirá en régimen de portes debidos (salvo correos y postal-express, en cuyo caso se enviará a portes pagados y posteriormente se cargará en factura), independientemente del importe del pedido.

4. Los precios establecidos en el presente catálogo no incluyen tasas o impuestos vigentes.

ALU-SYSTEM, S.A.U. podrá establecer descuentos promocionales o condiciones especiales por la cuantía de los pedidos, así como cualquier tipo de oferta por razones de estrategia comercial.

Estos descuentos, condiciones especiales y ofertas, no serán acumulables y tendrán el vigor temporal que ALU-SYSTEM, S.A.U. considere.

El % de descuento por pronto pago, quedará condicionado a que el cobro correspondiente se efectúe dentro de los 15 días posteriores a la emisión de la factura.

5. ALU-SYSTEM, S.A.U. no admitirá devoluciones de material que no estén previamente justificadas y comunicadas.

Los portes de las devoluciones correrán por cuenta del comprador.

ALU-SYSTEM, S.A.U. se reserva el derecho a efectuar abono sobre las devoluciones, quedando condicionado al examen del estado de la mercancía.

Salvo pacto en contra, el importe de los abonos se deducirá en próximas facturas.

6. Se establece un plazo de pago de 30 días, a contar desde la fecha de emisión de la factura, salvo pacto distinto entre ALU-SYSTEM, S.A.U. y el comprador con respecto a lo que la legislación vigente estipule.

La demora en el pago dará potestad a ALU-SYSTEM, S.A.U. a cargar los correspondientes intereses, paralizar pedidos en curso y/o reclamar la totalidad de importes adeudados por el comprador, aunque no estén vencidos.

El pago deberá hacerse en el domicilio social de ALU-SYSTEM, S.A.U. El hecho voluntario por parte de ALU-SYSTEM, S.A.U. de librar giros para mayor comodidad del comprador, no puede interpretarse como una renuncia al lugar de pago establecido.

7. Cualquier reclamación sobre la mercancía remitida por ALU-SYSTEM, S.A.U., deberá hacerla el comprador dentro del plazo de 8 días, a contar desde la recepción de la mercancía.

8. Hasta el pago total de las mercancías, ALU-SYSTEM, S.A.U. se reserva el dominio de éstas, sin asumir por su parte otros riesgos, (pérdida, deterioro, etc.).

En caso de que ALU-SYSTEM, S.A.U. tuviera que hacer uso de dicha reserva, los costes de reposición de materiales correrán a cargo del comprador.

9. El comprador se somete expresamente al fuero y competencia de los Juzgados y Tribunales de Barcelona, para dirimir cualquier cuestión o divergencia, renunciando a fueros propios.

10. ALU-SYSTEM, S.A.U. se reserva el derecho de modificar el contenido de estas condiciones generales de venta.

11. ALU-SYSTEM S.A.U. se reserva la libertad de modificar los precios de venta en caso de fuertes subidas de la materia prima.

12. ALU-SYSTEM S.A.U. no se hace responsable de los artículos instalados inadecuadamente ni de trabajos de sustitución.

13. El plazo de entrega de producto de procedencia internacional es orientativo, en caso de retraso se informará.

14. ALU-SYSTEM S.A.U. no acepta pedidos con cláusulas de penalización que no sean firmadas expresamente en un contrato específico.